



-  = INSTALLATION
DETAIL
-  = PARTS LIST
REFERENCE

HAND CYCLE (SURFACE MOUNT) UP216SM
HAND CYCLE (IN-GROUND) UP216S

APPLY USAGE/WARNING LABEL IN APPROXIMATE POSITION SHOWN

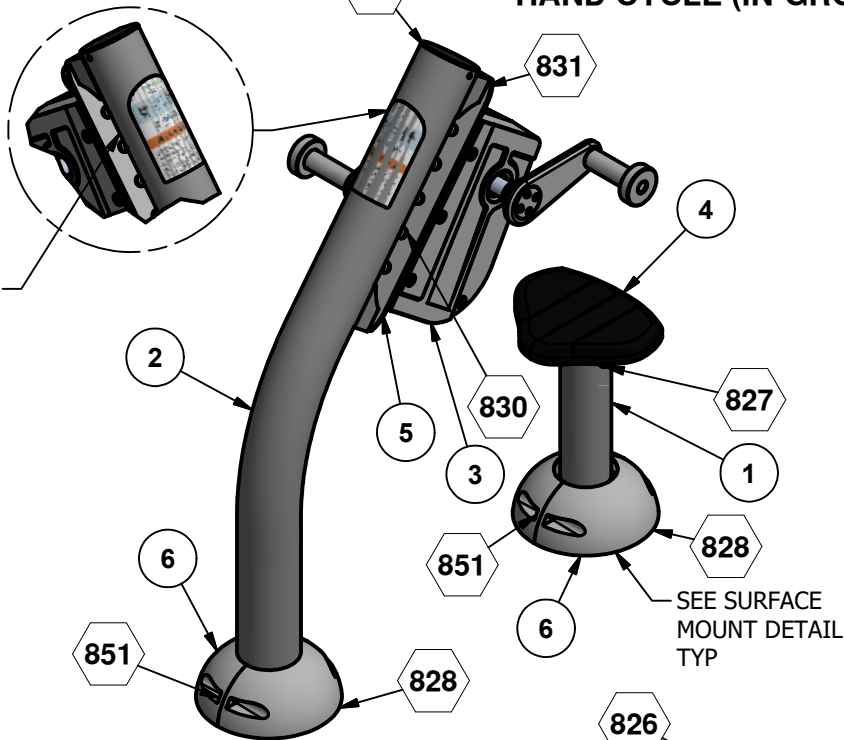

ASSEMBLY DRAWING
UP216SM

APPLY USAGE/WARNING LABEL IN APPROXIMATE POSITION SHOWN

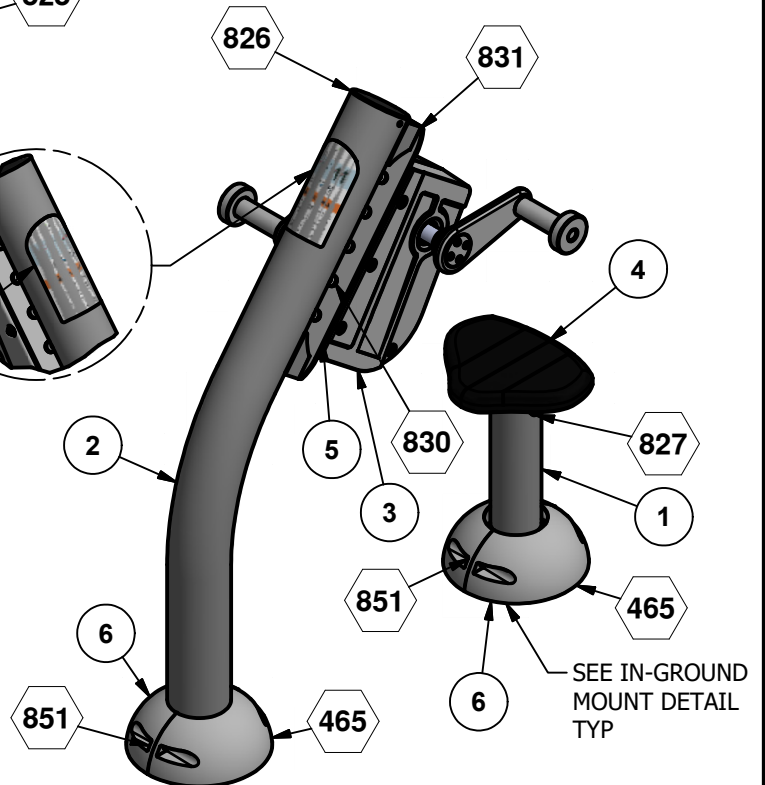

ASSEMBLY DRAWING
UP216S

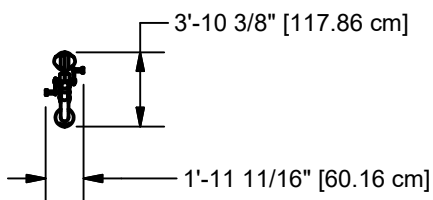

TOP VIEW

Parts List				
REF	DESCRIPTION	UP216SM	UP216S	PART NUMBER
1	CYCLE SEAT SUPPORT WELD ASSEMBLY (SM)	1	0	215102
1	CYCLE SEAT SUPPORT WELD ASSEMBLY	0	1	216545
2	HAND CYCLE ATTACHMENT WELD ASSEMBLY (SM)	1	0	215098
2	HAND CYCLE ATTACHMENT WELD ASSEMBLY	0	1	216542
3	HAND CYCLE ASSEMBLY	1	1	216516
4	ADA SEAT/BACKREST	1	1	207600
5	MOUNTING PLATE	1	1	216540
6	5" BASE COVER	2	2	207659
	USAGE/WARNING LABEL	1	1	403885
	HARDWARE COMPLETE	1	0	216548
	HARDWARE COMPLETE	0	1	216549
	5" INJECTION MOLDED CAP	1	1	207710*
	3/8" x 3/4" P.B.H.C.S. w/PATCH	4	4	812052*
	3/8" LOCK WASHER	4	4	817334*
	3/8" FLAT WASHER	4	4	817410*
	1/2" X 1" P.B.H.C.S. w/PATCH	14	14	812061*
	1/2" FLATWASHER (7/8" O.D.)	14	14	817465*
	1/2" LOCKWASHER	14	14	817342*
	1/2" HEX NUT	4	4	804055*
	3/4" LOCKWASHER	8	0	817354*
	3/4" x 4 1/4" WEDGE ANCHOR	8	0	206358*
	1/2" ANCHOR ROD	0	4	135038*
	3/16" x 13/32" DRIVE RIVET	2	2	805366*

*Unless Otherwise Specified, All Units of Measure are Each
* Included in Hardware*

**Warning: During Installation, Hardware And Small Parts Are Choking Hazards
For Young Children. Store Unused Parts Appropriately Until Assembly Is Completed.
Once Assembly Is Completed, Remove Any Unused Parts From The Play Environment
And Dispose/Save Them In A Secure Location.**

Note: Peen Tee-Nuts and Flatwashers to match radius of pipe after assembly is complete.

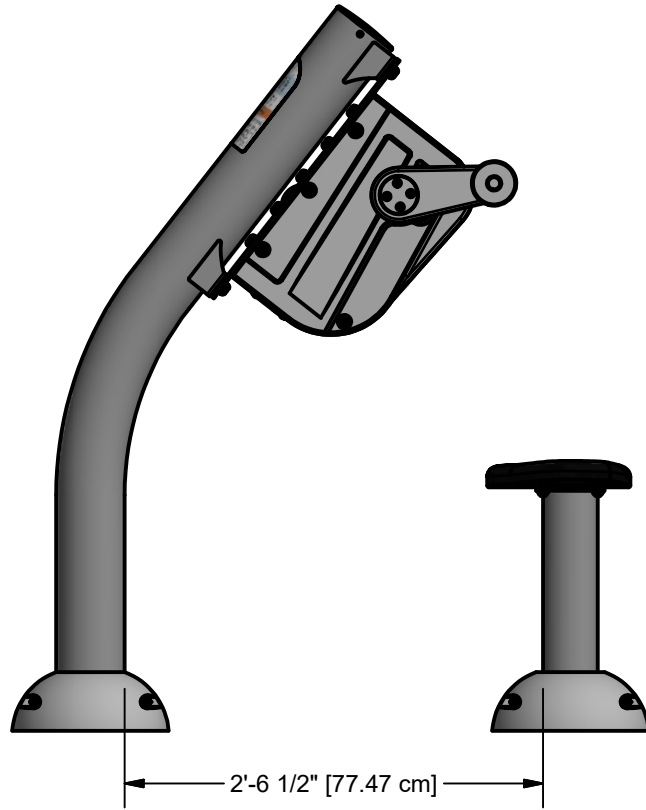

PLACEMENT DETAIL
UP216SM/UP216S

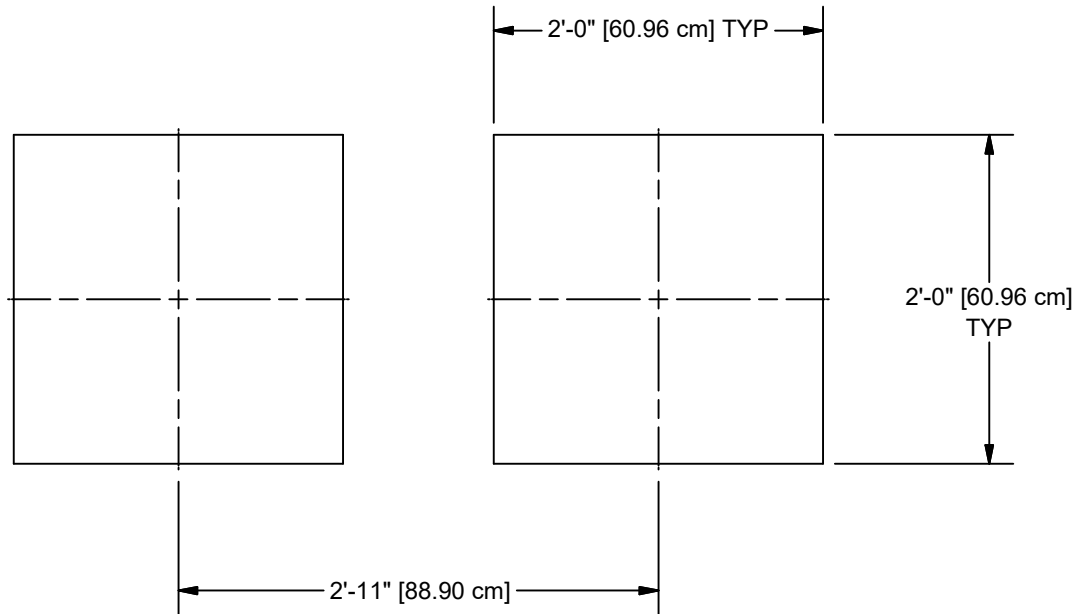

CONCRETE REQUIRED
 .60 CUBIC YARDS
 [.46 CUBIC METERS]

GROUND PLAN
UP216S

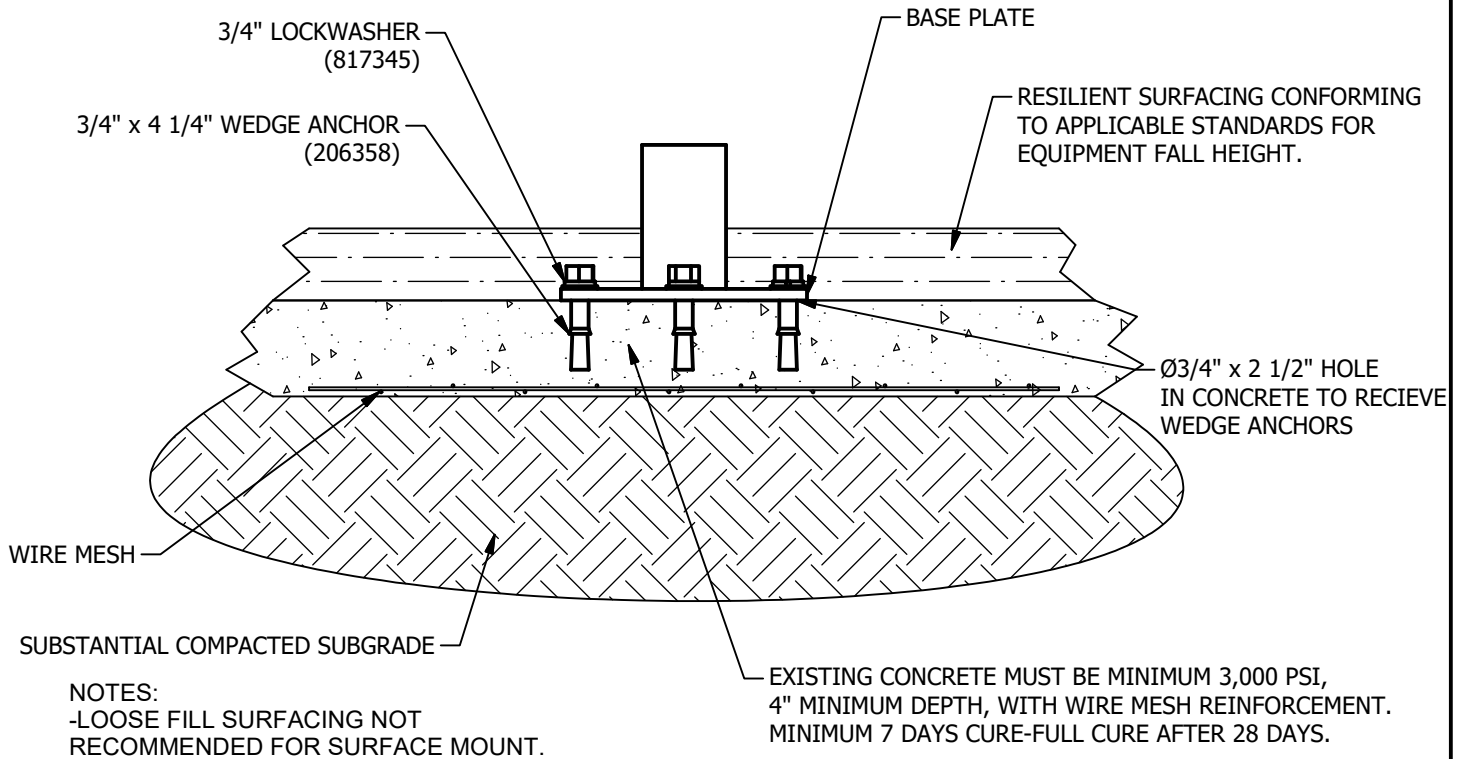

SURFACE MOUNT

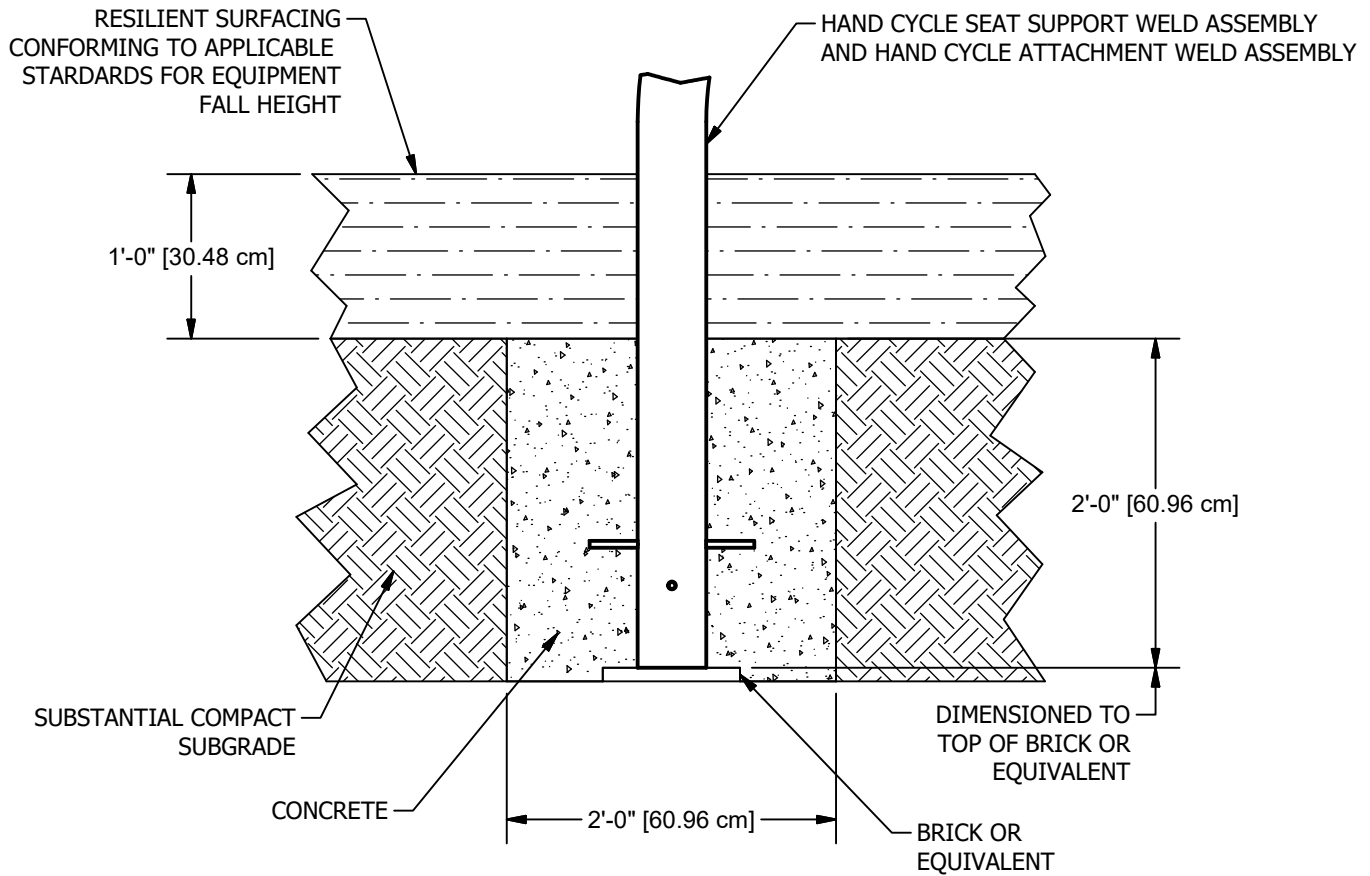
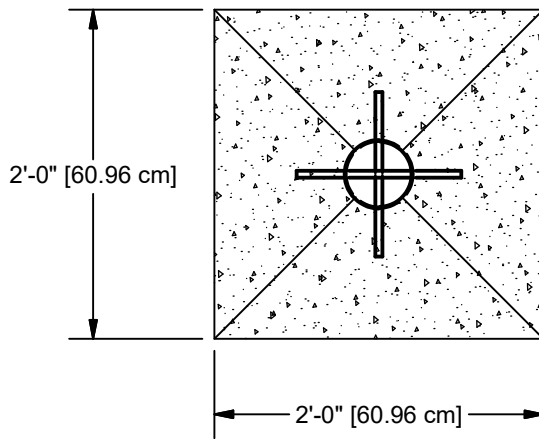

NOTES:

-RESILIENT SURFACING AND SUBSTANTIAL COMPACTED SUBGRADE DEPTHS DEPEND ON SOIL CONDITIONS AND RESILIENT SURFACING TYPE

-SLOPED FOOTING (45° MIN) IS A REQUIREMENT OF EUROPEAN STANDARD EN1176-1 ONLY

-SUGGESTED MINIMUM CONCRETE RATING 3000 PSI

SHOCK ABSORBING PROPERTIES OF SURFACING MATERIALS VARY. IF YOU DETERMINE THAT LESS THAN 1'-0" [30.48cm] OF SURFACING IS REQUIRED, MAKE UP THE DIFFERENCE IN ELEVATION WITH EARTH BEFORE APPLYING SURFACING.

IN-GROUND MOUNT



IMPORTANT PRODUCT INFORMATION AND SAFETY WARNINGS



- Installation over a hard surface such as concrete, asphalt, or packed earth may result in serious injury or death from fails. Especially all elevated upper-body strength building equipment.
- ALWAYS FOLLOW INSTALLATION INSTRUCTIONS WHEN ERECTING EQUIPMENT.
- Worn surfaces around equipment should be restored. Concrete footings should never be exposed. Surface depth should comply with installation instructions.
- Equipment should be placed to eliminate conflicting traffic patterns.
- All equipment should be free of rust and repainted whenever necessary to deter rusting.
- All protruding nuts and bolts should be covered; sharp edges on pipes should be capped or removed. Check for bent, broken or severely worn pipe and replace.
- Test overall stability and rigidity of all exercise equipment. Check for proper assembly, installation and ground anchoring.
- Check for and repair damage caused by wear or vandalism, a major factor in injury-causing situations.
- ActionFit® PROVIDES ITS CUSTOMERS WITH COMPLETE SPECIFICATION SHEETS AND INSTALLATION INSTRUCTIONS. THE SPECIFICATION SHEET CONTAINS THE LISTING OF EVERY PART USED IN A PIECE OF EQUIPMENT AND SHOULD BE KEPT IN THE CUSTOMER'S FILES FOR ACCURATE REFERENCE WHEN REPLACEMENT PARTS ARE NEEDED.
- Never add components not intended for use with this product.
- Regular checking of all parts, castings, etc. should be made. If a part is broken or worn it should be replaced immediately.
- Proper maintenance of ActionFit® equipment requires regular tightening of all bolts, nuts, and set screws.
- Check to be sure all fittings are tight and that the bars and pipes do not move.

INSTALLATION INSTRUCTIONS

NOTE: THIS INSTALLATION BOOKLET SHOULD BE KEPT IN CUSTOMER'S FILE FOR FUTURE REFERENCE.

NOTE: Do not overtighten bolts. To overtighten may cause buckling or dimpling of some parts.

NOTE: Read installation instructions thoroughly before starting assembly. Pour concrete only after final assembly is complete. Bracing material may be required during assembly.

NOTE: Do not tighten any nuts, bolts, rods, etc. until the unit is completely assembled.

NOTE: Assembly and leveling time will be greatly reduced if a transit is used to set location and depth of ground holes.

NOTE: Due to extremes in weather and soil conditions, hole sizes may have to be increased to meet local conditions

SURFACE MOUNT: Using Frame Assembly as template, mark hole locations for Wedge Anchors. Refer to Surface Mount Detail.

IMPORTANT: DO NOT MOUNT FRAME ASSEMBLY TO ANCHOR BOLTS FOR AT LEAST 7 DAYS, ALLOWING CONCRETE TO CURE.

SURFACE MOUNT VERSION

STEP 1: Place Component on concrete surface and mark location of holes in mounting plate. See Placement Detail.

STEP 2: Drill holes using 3/4" Diameter for a depth of 2 1/2" in concrete to receive Wedge Anchors.

STEP 3: Position Hand Cycle Seat Support Weld Assembly and Hand Cycle Attachment Weld Assembly and attach using Detail 828. See Surface Mount Detail.

STEP 4: Attach Seat to Hand Cycle Seat Support Weld Assembly using Detail 827.

STEP 5: Attach Mounting Plate to Hand Cycle Assembly using Detail 830.

STEP 6: Attach Mounting Plate to Hand Cycle Attachment Weld Assembly using Detail 831

STEP 7: Attach Pipe Cap to Hand Cycle Attachment Weld Assembly using Detail 826.

STEP 8: Attach Base Cover to Cycle Seat Support Weld Assembly and Hand Cycle Attachment Weld Assembly using Detail 851.

STEP 9: Level and plumb entire unit. Tighten all hardware.

IN-GROUND VERSION

STEP 1: Dig holes according to In-Ground Mount Detail and Ground Plan.

STEP 2: Attach Seat to Hand Cycle Seat Support Weld Assembly using Detail 827.

STEP 3: Attach Mounting Plate to Hand Cycle Assembly using Detail 830.

STEP 4: Attach Mounting Plate to Hand Cycle Attachment Weld Assembly using Detail 831

STEP 5: Attach Pipe Cap to Hand Cycle Attachment Weld Assembly using Detail 826.

STEP 6: Place Anchor Rod into Assemblies using Detail 465.

STEP 7: Place Assemblies into Ground Holes. See Placement Detail. Level and plumb entire unit. Tighten all hardware.

STEP 8: Attach Base Cover to Cycle Seat Support Weld Assembly and Hand Cycle Attachment Weld Assembly using Detail 851.

IMPORTANT: Level using sway bracing. Pour concrete according to In-Ground Mount Detail. Allow concrete to cure for a minimum of 7 days.

SPECIFICATIONS

HAND CYCLE SEAT SUPPORT WELD: An all weld assembly fabricated of 4" O.D. x .226" wall galvanized steel tubing (SCH 40) and 1/4" Thick H.R. Steel. The welded assembly shall be coated after fabrication with a custom formula of TGIC polyester powder coating in conformance with the specifications outlined herein.

HAND CYCLE ATTACHMENT WELD: An all weld assembly fabricated of 5" O.D. x .120" (11 Gauge) wall galvanized steel tubing and 1/8" Thick H.R. Steel. The welded assembly shall be coated after fabrication with a custom formula of TGIC polyester powder coating in conformance with the specifications outlined herein.

MOUNTING PLATE: Shall be fabricated of 1/4" thick HR steel. The plate shall be coated after fabrication with a custom formula of TGIC polyester powder coating in conformance with the specifications outlined herein.

SEAT/BACKREST: Shall be constructed from injection molded Nylon W6.

HAND CYCLE ASSEMBLY:

MECHANISM CASTING: Shall be fabricated from A365 Cast Aluminum. The castings shall be coated after fabrication with a custom formula of TGIC polyester powder coating in conformance with the specifications outlined herein.

HAND CRANK ASSEMBLY: The Hand Crank Assembly consists of an HDPL crank arm, an Aluminum machined part, a (16 Gauge) H.R. Steel plate, and a welded handle assembly of 1-5/8" and 3-1/4" O.D. cold rolled steel that shall be coated after fabrication with a custom formula of TGIC polyester powder coating in conformance with the specifications outlined herein.

SLOT COVER PLATE: Shall be fabricated from 16 Gauge H.R. Steel Plate.

MECHANISM: The mechanism is a purchased part and shall be made of stainless cold rolled steel and utilizes magnetic resistance.

BASE COVER: Shall be constructed from aluminum and powder coated.

PIPE CAP: Shall be constructed from injection molded polyethylene

POWDER COAT FINISH: Shall be an electrostatically applied custom formula of TGIC polyester powder. All components will be free of sharp edges and excess weld spatter and shall be cleaned in a four stage solvent / zirconium based bath system (free of iron phosphate), as a rust inhibitor, and a zirconium conversion coating to prevent flash rusting before coating. In addition, all welds shall be protectively coated with ZRP, a zinc rich primer that forms a rust-resistant barrier layer over each weld prior to application of the powder coating. The powder coating shall have a super tough finish with maximum exterior durability and will have superior adhesion characteristics. Typical characteristics are: Two coat process to achieve 3.0 - 5.0 mil thickness and oven cured between 350 degrees Fahrenheit. Pencil Hardness H (ASTM D-3363), Impact (ASTM D-2794- 69), Wedge Bend (ASTM D-522-68), Adhesion (Cross Hatch ASTM D-3359 & Knife Scratch ASTM D-2197), Environmental (Stain Resistance ASTM D-1308, Humidity ASTM D-2247 - 87, Salt Spray ASTM B-117 & Fadometer 300 hrs with no loss of gloss), Over-bake Stability 100% at 350 degrees Fahrenheit for 10 minutes.

HARDWARE: All nuts, bolts, screws, inserts, and lockwashers used in the assembly of all play equipment, shall be stainless steel, yellow dichromate plated steel, blue-coat plated steel, mechanically galvanized or powder coated/yellow dichromate plated steel. All primary fasteners shall be 300 series stainless steel. Fasteners with yellow dichromate treatment have an electro deposited, 99.9% pure zinc substrate applied from a specially formulated solution sealed with a yellow dichromate top coat designed to work in conjunction with the zinc plating. Yellow dichromate has a 320% longer life to white corrosion and 275% longer to red corrosion than does hot-dip galvanizing. NOTE: All weights are based on average comparisons of each part.

SPECIFICATIONS: ActionFit® has a policy of continuous improvement and reserves the right to discontinue or change specifications without notice.

DETAILS -for- UP216

IMPORTANT

TO REDUCE THE RISK OF CLOTHING ENTANGLEMENT IN COMPLIANCE WITH ASTM F1487, ANY BOLT END
PROTRUDING MORE THAN TWO FULL THREADS BEYOND THE FACE OF THE NUT SHALL BE CUT-OFF FLUSH, FILED
SMOOTH AND TREATED TO PREVENT CORROSION.

NOTE: LOCTITE (SUPPLIED BY OTHERS) SHOULD BE USED ON ALL THREADED HARDWARE.

NOTE: AFTER ASSEMBLY IS COMPLETE, PEEN TEE-NUTS AND FLATWASHERS TO MATCH RADIUS OF PIPE.

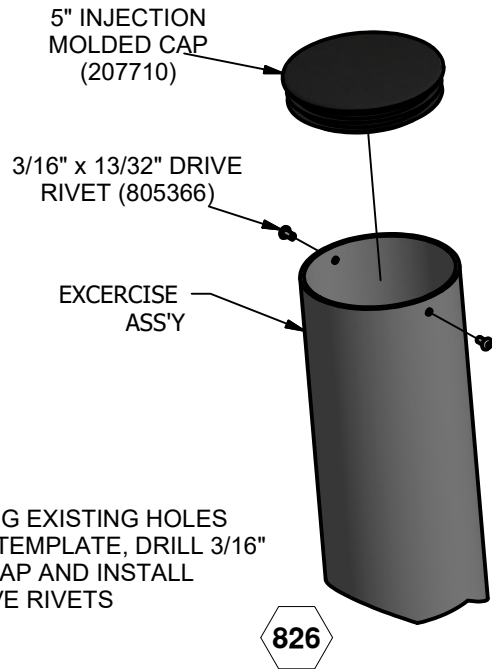
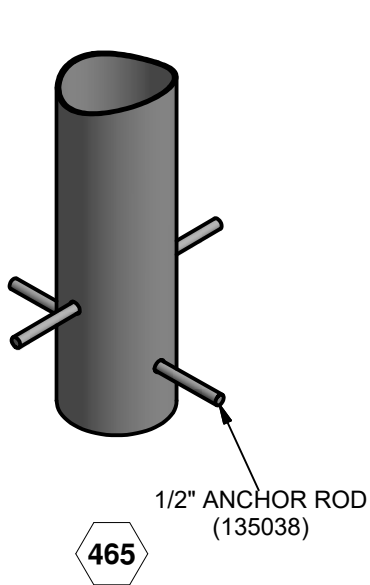
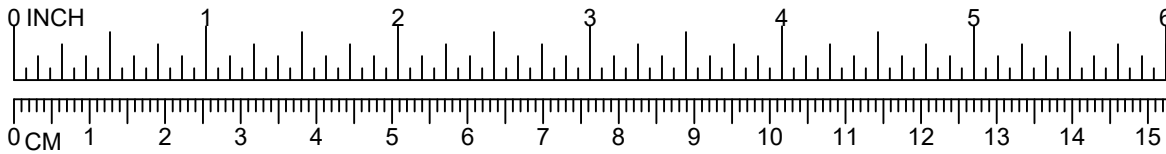

NOTE: USING EXISTING HOLES
IN PIPE AS TEMPLATE, DRILL 3/16"
HOLES IN CAP AND INSTALL
USING DRIVE RIVETS

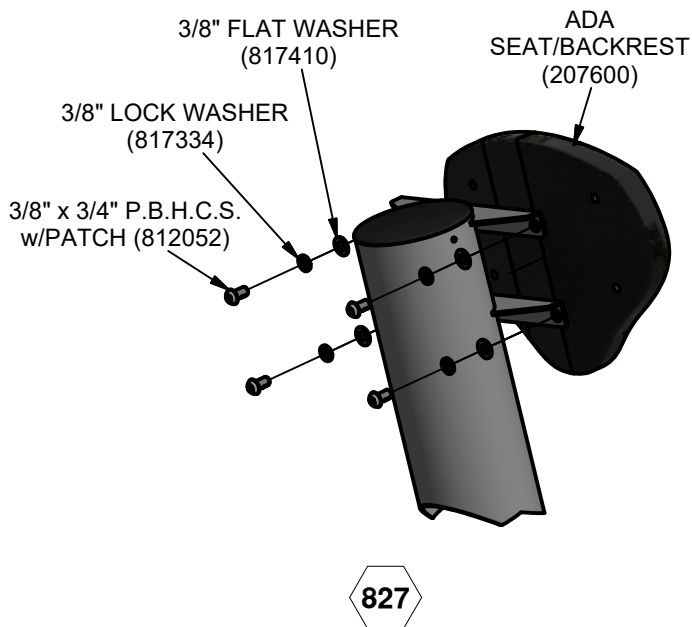

DETAILS -for- UP216SM

IMPORTANT

TO REDUCE THE RISK OF CLOTHING ENTANGLEMENT IN COMPLIANCE WITH ASTM F1487, ANY BOLT END PROTRUDING MORE THAN TWO FULL THREADS BEYOND THE FACE OF THE NUT SHALL BE CUT-OFF FLUSH, FILED SMOOTH AND TREATED TO PREVENT CORROSION.

NOTE: LOCTITE (SUPPLIED BY OTHERS) SHOULD BE USED ON ALL THREADED HARDWARE.

NOTE: AFTER ASSEMBLY IS COMPLETE, PEEN TEE-NUTS AND FLATWASHERS TO MATCH RADIUS OF PIPE.

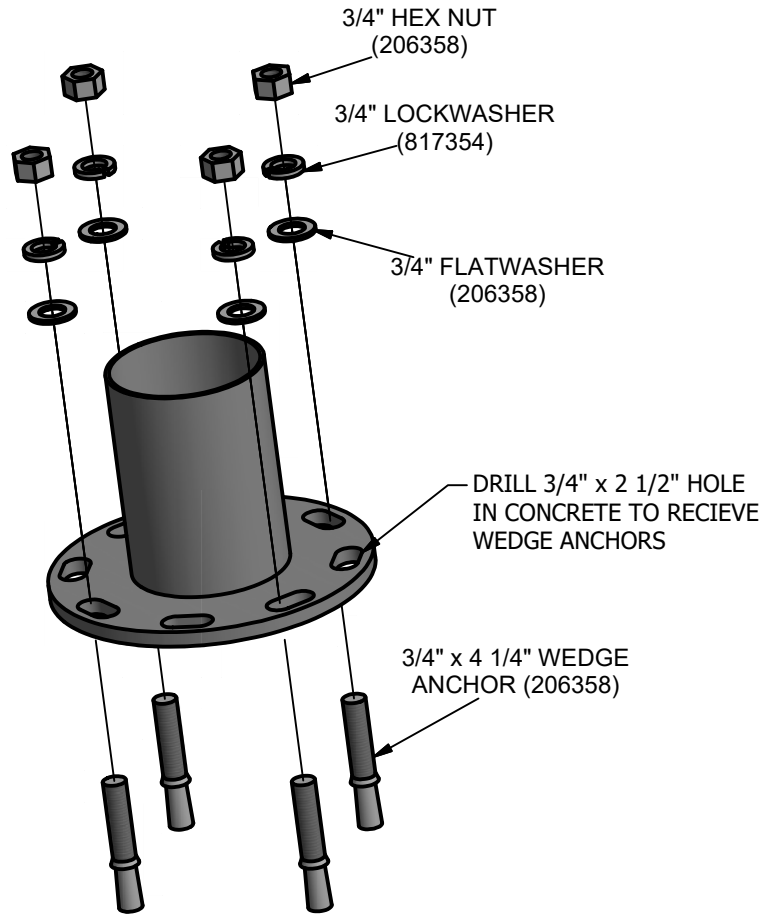
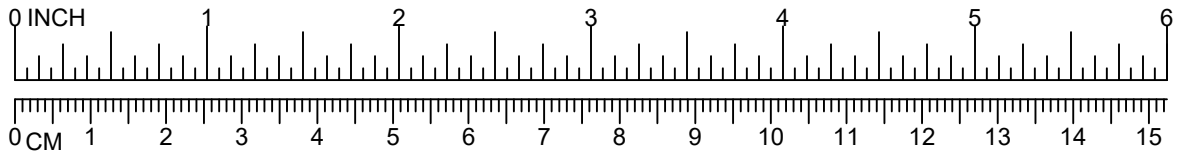

828

DETAILS -for- UP216

IMPORTANT

TO REDUCE THE RISK OF CLOTHING ENTANGLEMENT IN COMPLIANCE WITH ASTM F1487, ANY BOLT END
PROTRUDING MORE THAN TWO FULL THREADS BEYOND THE FACE OF THE NUT SHALL BE CUT-OFF FLUSH, FILED
SMOOTH AND TREATED TO PREVENT CORROSION.

NOTE: LOCTITE (SUPPLIED BY OTHERS) SHOULD BE USED ON ALL THREADED HARDWARE.

NOTE: AFTER ASSEMBLY IS COMPLETE, PEEN TEE-NUTS AND FLATWASHERS TO MATCH RADIUS OF PIPE.

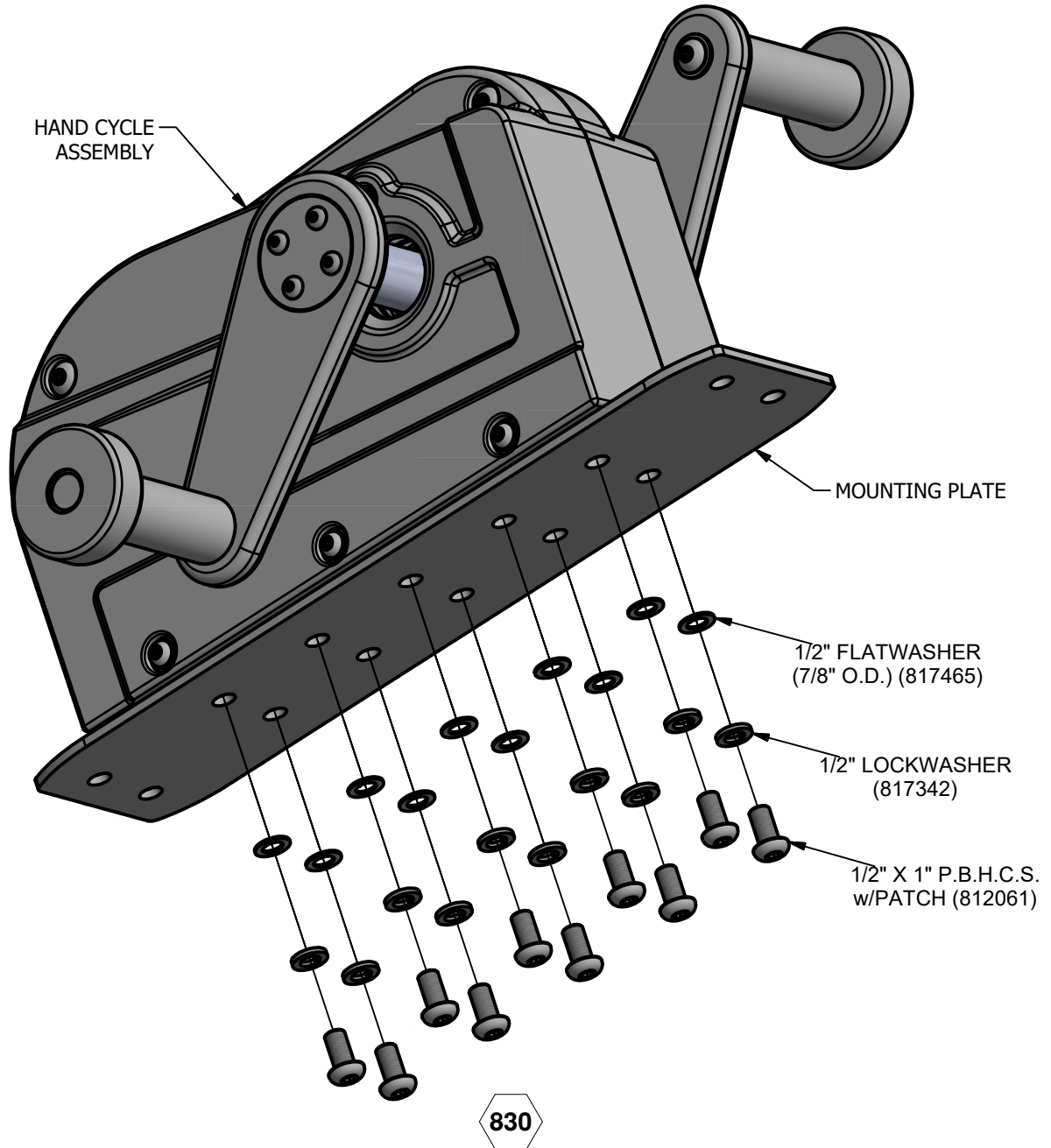
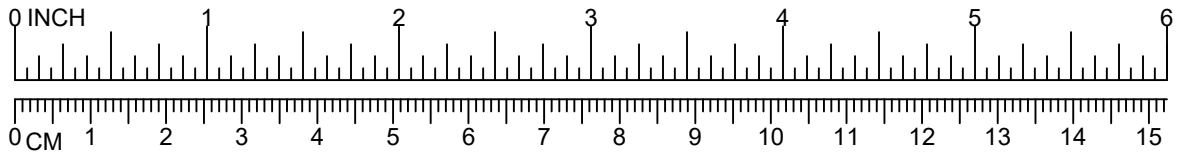

DETAILS -for- UP216

IMPORTANT

TO REDUCE THE RISK OF CLOTHING ENTANGLEMENT IN COMPLIANCE WITH ASTM F1487, ANY BOLT END PROTRUDING MORE THAN TWO FULL THREADS BEYOND THE FACE OF THE NUT SHALL BE CUT-OFF FLUSH, FILED SMOOTH AND TREATED TO PREVENT CORROSION.

NOTE: LOCTITE (SUPPLIED BY OTHERS) SHOULD BE USED ON ALL THREADED HARDWARE.

NOTE: AFTER ASSEMBLY IS COMPLETE, PEEN TEE-NUTS AND FLATWASHERS TO MATCH RADIUS OF PIPE.

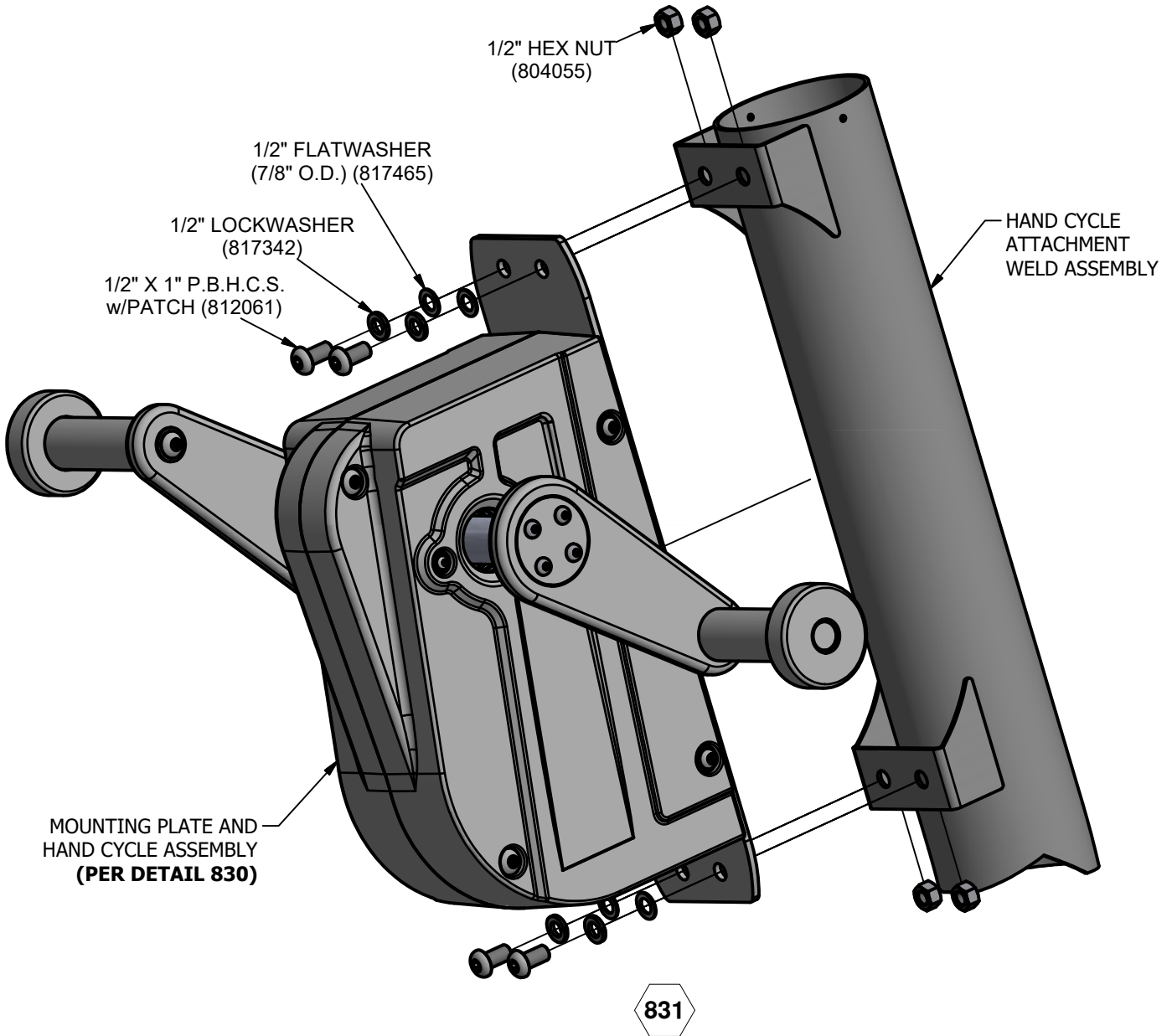
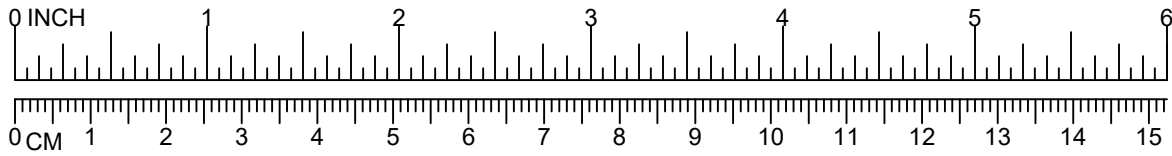

DETAILS -for- UP216

IMPORTANT

TO REDUCE THE RISK OF CLOTHING ENTANGLEMENT IN COMPLIANCE WITH ASTM F1487, ANY BOLT END PROTRUDING MORE THAN TWO FULL THREADS BEYOND THE FACE OF THE NUT SHALL BE CUT-OFF FLUSH, FILED SMOOTH AND TREATED TO PREVENT CORROSION.

NOTE: LOCTITE (SUPPLIED BY OTHERS) SHOULD BE USED ON ALL THREADED HARDWARE.

NOTE: AFTER ASSEMBLY IS COMPLETE, PEEN TEE-NUTS AND FLATWASHERS TO MATCH RADIUS OF PIPE.

