

UP179J CHEST PRESS ACCESSIBLE (FOOTING) UP179S CHEST PRESS ACCESSIBLE (IN GROUND) UP179SM CHEST PRESS ACCESSIBLE (SURFACE)

Parts List				
DESCRIPTION	UP179J (FOOTING)	UP179S (IN GROUND)	UP179SM (SURFACE)	PART NUMBER
ADA CHEST PRESS ASS'Y	1	1	1	206967
HANDLE BAR	1	1	1	206959
ADA HANDLE BAR	1	1	1	206964
ADA SEAT/BACKREST	2	2	2	207600
CUSHION	1	1	1	209075
5" BASE COVER	1	1	1	207659
FOOTBUCK WELD ASS'Y	0	1	0	206467
HARDWARE COMPLETE	0	0	1	207605
HARDWARE COMPLETE	1	0	0	207606
HARDWARE COMPLETE	0	1	0	207607
1/2" ANCHOR ROD	0	2	0	135038*
3/4" x 4 1/4" WEDGE ANCHOR	0	0	4	206358*
5" INJECTION MOLDED CAP	1	1	1	207710*
3/4" ANCHOR BOLT	4	0	0	800001*
3/4" x 2" HEX HEAD CAP SCREW	0	4	0	801533*
3/4" HEX NUT	8	4	0	804058*
3/8" x 3/4" P.B.H.C.S. w/PATCH	8	8	8	812052*
3/8" LOCKWASHER	8	8	8	817334*
3/4" LOCKWASHER	4	4	4	817354*
3/8" FLAT WASHER	8	8	8	817410*
3/4" FLATWASHER (2" O.D.)	8	4	0	817420*
1/2" FLAT WASHER	4	4	4	817412*
12MM DO-NUT BASE	4	4	4	G034BK*
12MM DO-NUT CAP	4	4	4	G036BK*
MACHINED SHAFT	2	2	2	206986*
1/2" FLATWASHER	4	4	4	817700*
1/2" x 1 1/4" B.H.C.S.	4	4	4	811062*
USAGE/WARNING LABEL	1	1	1	403883*
USAGE/WARNING LABEL	1	1	1	403904*

Unless Otherwise Specified, All Units of Measure are Each

*Items listed below Hardware Complete line are included with Hardware Complete Number

Warning: During Installation, Hardware And Small Parts Are Choking Hazards For Young Children. Store Unused Parts Appropriately Until Assembly Is Completed. Once Assembly Is Completed, Remove Any Unused Parts From The Play Environment And Dispose/Save Them In A Secure Location. Any bolt end protruding more than two full threads beyond the face of the nut causes risk of clothing entanglement. Promptly cut-off flush, file smooth, and treat to prevent corrosion.

Note: Peen Tee-Nuts and Flatwashers to match radius of pipe after assembly is complete.

Note: Loctite (supplied by others) should be used on any non-patch hardware.

UP179J CHEST PRESS ACCESSIBLE (FOOTING) UP179S CHEST PRESS ACCESSIBLE (IN GROUND) UP179SM CHEST PRESS ACCESSIBLE (SURFACE)

SPECIFICATIONS

BACKREST/SEAT/CUSHION: The Backrest, Cushion, and seat shall be constructed from injection molded Nylon W6.

BASE COVER: The Base Cover shall be constructed from aluminum and powder coated.

BOLT BASE AND CAP: The Bolt Base and Cap shall be constructed from Nylon PA6, and shall be black in color.

5" PLASTIC CAP: The 5" Plastic Cap shall be constructed from injection molded Low Density Polyethylene.

WELD ASSEMBLIES:

HANDLEBAR: The handlebar assemblies shall be constructed from 1.66" O.D. x 0.109" steel tubing. The assemblies shall be coated with a custom formula of TGIC polyester powder, after fabrication in conformance with the specifications outlined herein.

MAIN POST: Main Post assembly shall be manufactured with 2 15/16" x 9" and 1/8" thick hot rolled laser cut steel plate, 1/2" thick 10 1/4" dia. hot rolled laser cut steel plate, 2.375" O.D. x 0.154" SCH 40 pipe, 3.5" O.D. x 0.216" SCH 40 pipe, 4.5" O.D. x 0.25" SCH 40 pipe and 5" O.D. galvanized upright. The upright shall be 11 gauge (.120") galvanized round tubing, manufactured to ASTM A-500 Grade B tolerances from cold-formed steel conforming to ASTM A-569 Sheet Spec for steel coil. Minimum yield strength shall be 50,000 psi and minimum tensile strength shall be 55,000 psi. The exterior surface is hot dip galvanized, chromate conversion coated, and a clear high performance organic polymer is applied. The inside diameter has 81% minimum zinc rich primer capable of providing excellent rust protection and fabrication characteristics. All coatings are applied inside and out after welding for superior corrosion protection throughout. Exterior surface galvanizing zinc purity is 99% as per ASTM B-6 high grade and special high grade. Galvanizing coverage shall demonstrate the ability to exceed 1000 hours salt spray corrosion exposure in accordance with ASTM B-117. Internal surface zinc rich 81% minimum zinc dust content in organic resin, as per ASTM F-1234, Section 5.2.4, Type D. The main support frame assemblies and formed supports shall be coated with a custom formula of TGIC polyester powder, after fabrication in conformance with the specifications outlined herein.

MECHANISM PARTS:

BEARING HOLDER: Shall be manufactured with 4.245" O.D. stain steel machined tubing.

DISK BEARING: The disk bearing should be pre lubricated 3 3/8" O.D. 1 1/8" square bore stainless steel bearing.

MACHINED SHAFT: The machine shaft shall be manufactured with 1 3/16" x 9 1/8" stainless steel shaft.

RUBBER SPRING: Shall consist of rubber encapsulated by cast steel with a steel inner core.

FOOTBUCK: The upright shall be fabricated of 5" O.D. galvanized pipe and the mounting plate shall be a fabricated 3/8" hot rolled flat steel. Shall be a once piece welded unit.

POWDER COAT FINISH: Shall be an electrostatically applied custom formula of TGIC polyester powder. All components will be free of sharp edges and excess weld spatter and shall be cleaned in a six stage bath system with an iron phosphate wash, as a rust inhibitor, and a sealer to prevent flash rusting before coating, The coating shall have a super tough finish with maximum exterior durability and will have superior adhesion characteristics. Typical Characteristics are: 3.0 - 5.0 mil thickness and oven cured between 375 to 425 degrees Fahrenheit. Pencil Hardness H (ASTM D-3363), Impact (ASTM D-2794-69), Wedge Bend (ASTM D-522-68).

HARDWARE: All nuts, bolts, screws, and lock washers used in the assembly shall be stainless steel, yellow dichromate plated steel, blue-coat plated steel, mechanically galvanized or powder coated/yellow dichromate plated steel. All primary fasteners shall be 304 alloy stainless steel. Fasteners with yellow dichromate treatment have an electro-deposited, 99.9% pure zinc substrate applied from a specially formulated solution sealed with a yellow dichromate top coat designed to work in conjunction with the zinc plating.

UP179J CHEST PRESS ACCESSIBLE (FOOTING) UP179S CHEST PRESS ACCESSIBLE (IN GROUND) UP179SM CHEST PRESS ACCESSIBLE (SURFACE)

NOTE: Do not overtighten bolts. To overtighten may cause buckling or dimpling of some parts.

NOTE: Read installation instructions thoroughly before starting assembly. Pour concrete only after final assembly is completed. Bracing material is required during assembly.

NOTE: Assembly and leveling times will be greatly reduced if a transit is used to set location and depth of ground holes.

INSTALLATION INSTRUCTIONS FOR UP179J (FOOTING):

1. Dig holes or drill holes according to Plan View and Elevation View. **NOTE:** Due to extremes in weather and soil conditions, hole size may have to be increased to meet local conditions.
2. Fill hole with concrete. While the concrete is still soft, yet firm enough to support the Chest Press, Place (4) Anchor Bolts of the Chest Press in position. See Footing Detail. **NOTE:** Use Chest Press as a template for Anchor Bolt location, then remove Chest Press.

IMPORTANT: DO NOT MOUNT THE CHEST PRESS TO THE ANCHOR BOLTS FOR AT LEAST 7 DAYS.

3. After concrete has cured and set for a minimum of 7 Days, attach Chest Press to 3/4" Anchor Bolt using 3/4" Flat Washer (2" O.D.), 3/4" Lock Washer, and 3/4" Hex Nut. See Footing Assembly Detail.
4. Attach Base Cover to Equipment Post using Base Cover Nut and Base Cover Bolt included with Base Cover. See Base Cover Detail.
5. Attach Handles to Chest Press Assembly using Bolt Base and Cap, 1/2" x 1 1/4" B.H.C.S, 1/2" Flatwashers, and Machined Shaft. See Handle assembly detail.
6. Attach Seat to Chest Press Assembly using 3/8" x 3/4" P.B.H.C.S. w/Patch, 5/16" Lockwasher, and 5/16 Flatwasher. See ADA Seat Detail. Attach Cushion using supplied hardware. See Cushion Detail.
7. Insert injection molded cap to top of assembly. See 5" Cap Detail.

INSTALLATION INSTRUCTIONS FOR UP179S (IN-GROUND):

1. Dig holes or drill holes according to Plan View and Elevation View. **NOTE:** Due to extremes in weather and soil conditions, hole size may have to be increased to meet local conditions.
2. Attach the Footbuck Weld Assembly to the Chest Press using 3/4" Hex Nut, 3/4" Lockwasher, 3/4" Flatwasher (2" O.D.), and 3/4" x 2" Hex Head Cap Screw. See In-Ground Assembly Detail.
3. Place Chest Press into hole making sure it rests on the brick. See In-Ground Detail.
4. Level Chest Press using sway bracing.
5. Pour concrete according to the Plan View and Elevation View. Allow concrete to cure for a minimum of 7 days.
6. Attach Base Cover to Equipment Post using Base Cover Nut and Base Cover Bolt included with Base Cover. See Base Cover Detail.
7. Attach Seat to Chest Press Assembly using 3/8" x 3/4" P.B.H.C.S. w/Patch, 5/16" Lockwasher, and 5/16 Flatwasher. See ADA Seat Detail. Attach Cushion using supplied hardware. See Cushion Detail.

**UP179J CHEST PRESS ACCESSIBLE (FOOTING)
UP179S CHEST PRESS ACCESSIBLE (IN GROUND)
UP179SM CHEST PRESS ACCESSIBLE (SURFACE)**

8. Insert injection molded cap to top of assembly. See 5" Cap Detail.

INSTALLATION INSTRUCTIONS FOR UP179SM (SURFACE):

1. Mark correct location of holes for Wedge Anchor using the Base Plate as a guide.
2. Drill 3/4" x 2 1/2" hole in concrete for Wedge Anchor. See Surface Detail.
3. Insert Wedge Anchors and secure with 3/4" Flatwasher (2" O.D.), 3/4" Lockwasher, and 3/4" Hex Nut. See Surface Assembly Detail.
4. Attach Base Cover to Equipment Post using Base Cover Nut and Base Cover Bolt included with Base Cover. See Base Cover Detail.
5. Attach Seat to Chest Press Assembly using 3/8" x 3/4" P.B.H.C.S. w/Patch, 5/16" Lockwasher, and 5/16 Flatwasher. See ADA Seat Detail. Attach Cushion using supplied hardware. See Cushion Detail.
6. Insert injection molded cap to top of assembly. See 5" Cap Detail.

UP179J CHEST PRESS ACCESSIBLE (FOOTING) UP179S CHEST PRESS ACCESSIBLE (IN GROUND) UP179SM CHEST PRESS ACCESSIBLE (SURFACE)

MAINTENANCE PROCEDURE:

Periodically check hardware for tightness, and tighten as necessary. Always check all parts for breakage or wear, and immediately put equipment out of service until any faulty parts found are repaired or replaced. Also Check all metal parts for rust, paint loss and touch-up if necessary with paint. Check for welded areas and verify integrity. Check periodically resilient surfacing for appropriate depth and remove extraneous materials that could cause injury, infection, or disease. Maintain detailed installation, inspection, maintenance, and repair records for each public-use playground equipment.

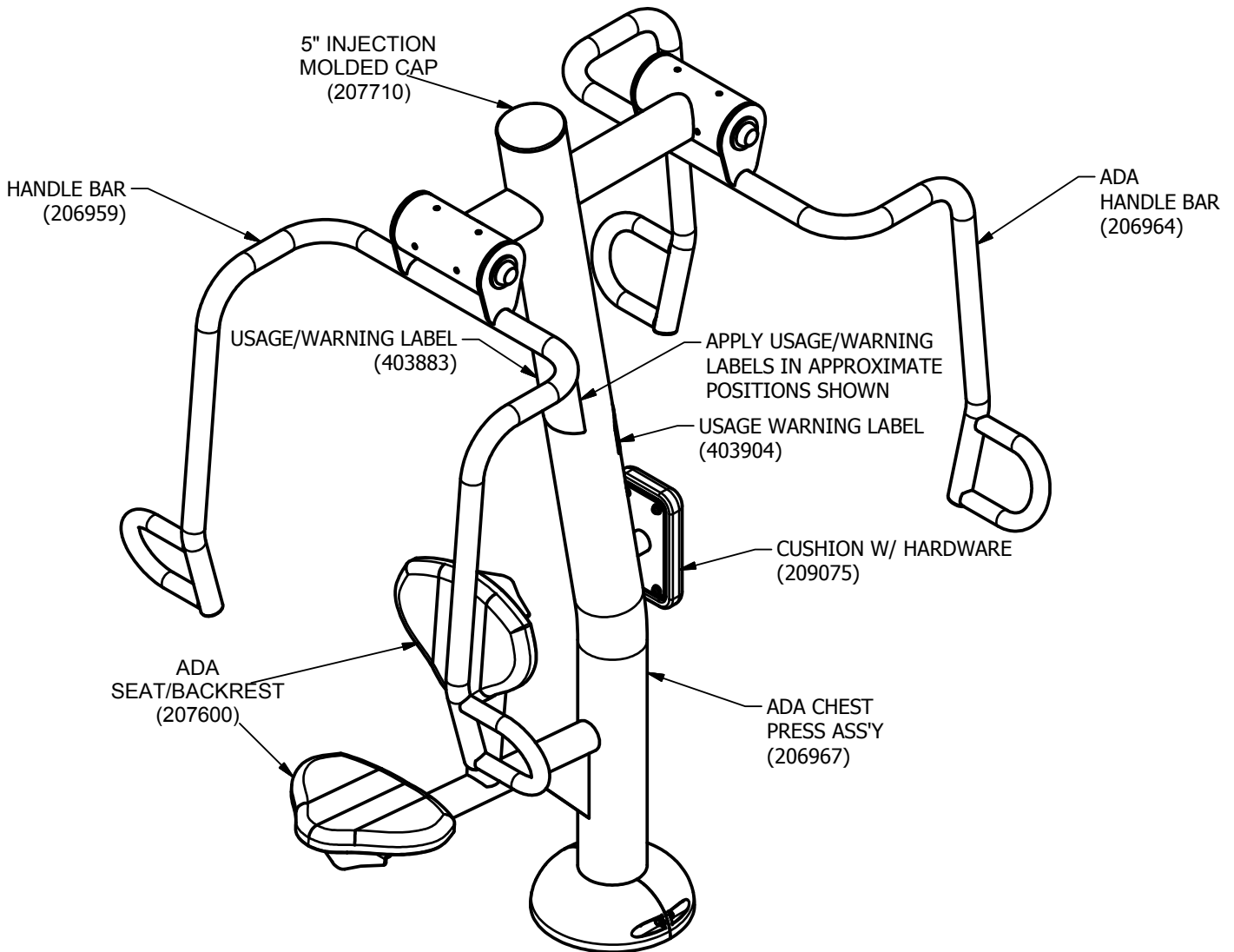

FINISHED ASSEMBLY

Issued/Revised: 10/10/16

UP179J CHEST PRESS ACCESSIBLE (FOOTING)
UP179S CHEST PRESS ACCESSIBLE (IN GROUND)
UP179SM CHEST PRESS ACCESSIBLE (SURFACE)

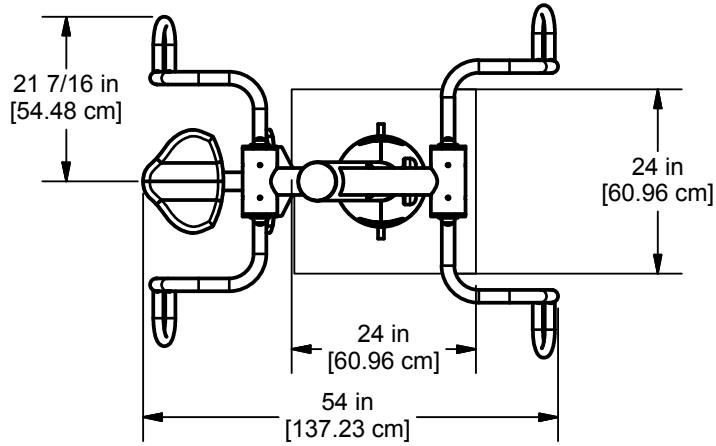

PLAN VIEW

UP179J (FOOTING)

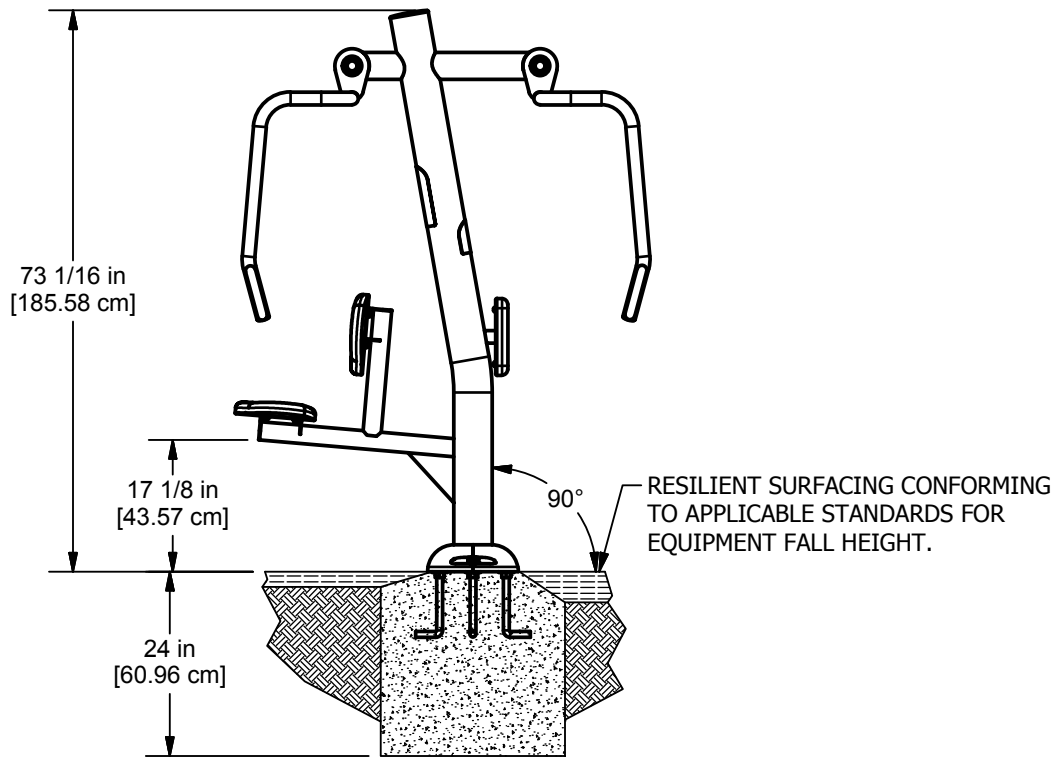

ELEVATION VIEW

UP179J (FOOTING)

UP179J CHEST PRESS ACCESSIBLE (FOOTING)
UP179S CHEST PRESS ACCESSIBLE (IN GROUND)
UP179SM CHEST PRESS ACCESSIBLE (SURFACE)

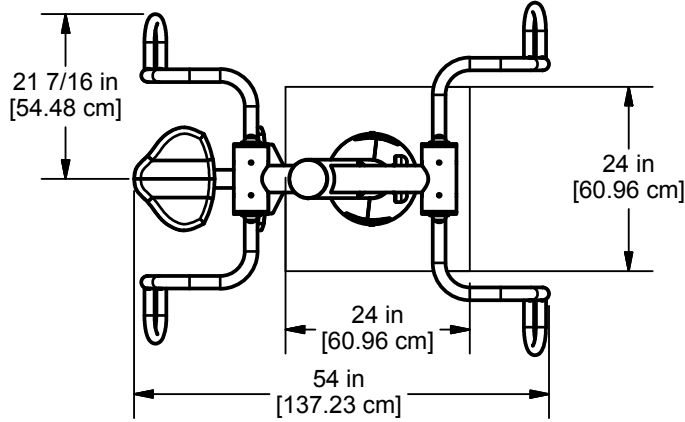

PLAN VIEW

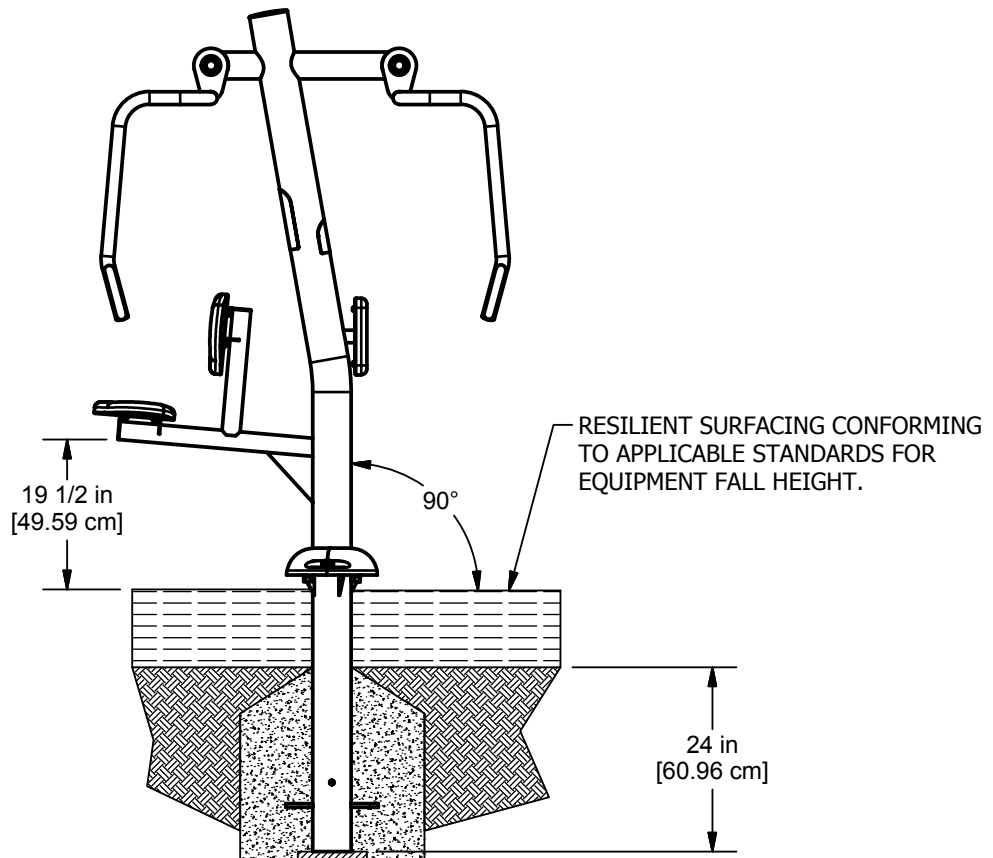

ELEVATION VIEW
UP179S (IN GROUND)

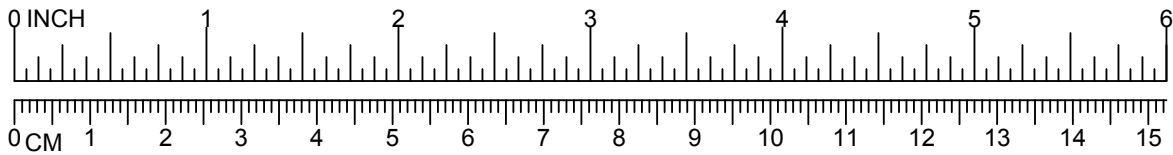

**UP179J CHEST PRESS ACCESSIBLE (FOOTING)
 UP179S CHEST PRESS ACCESSIBLE (IN GROUND)
 UP179SM CHEST PRESS ACCESSIBLE (SURFACE)**

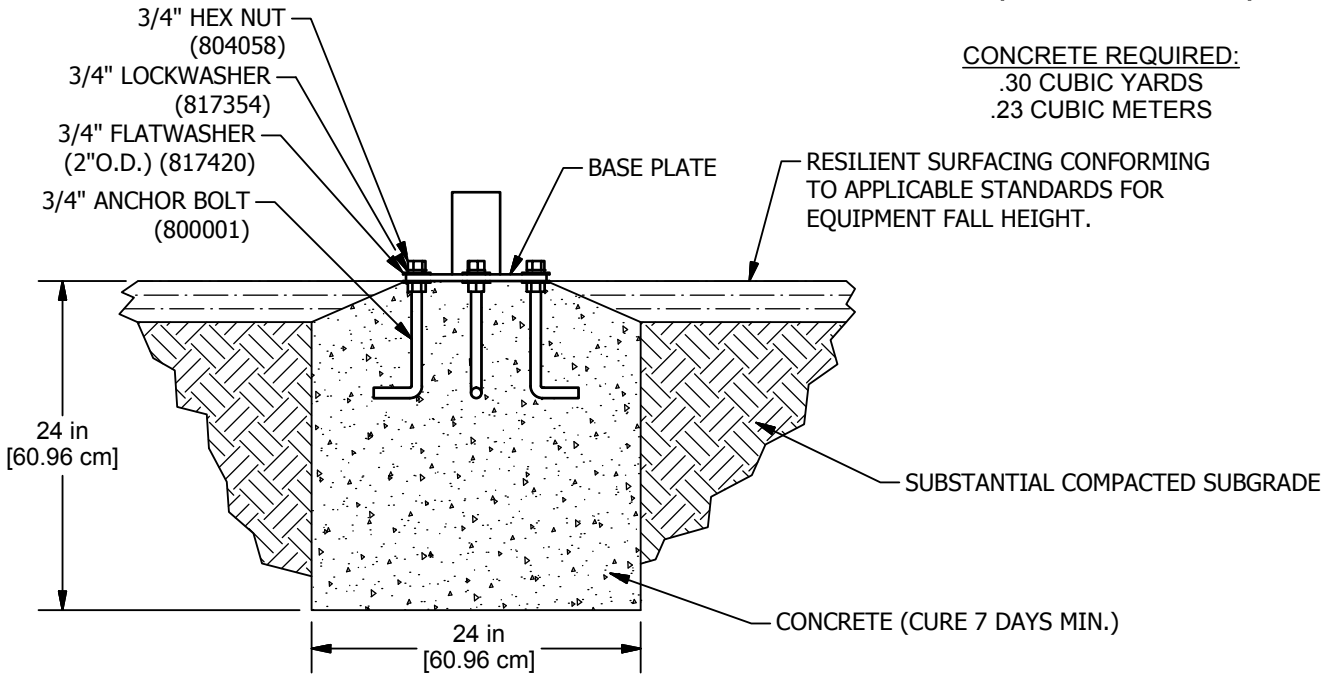

CONCRETE REQUIRED:
 .30 CUBIC YARDS
 .23 CUBIC METERS

RESILIENT SURFACING CONFORMING TO APPLICABLE STANDARDS FOR EQUIPMENT FALL HEIGHT.

SUBSTANTIAL COMPACTED SUBGRADE

CONCRETE (CURE 7 DAYS MIN.)

FOOTING DETAIL

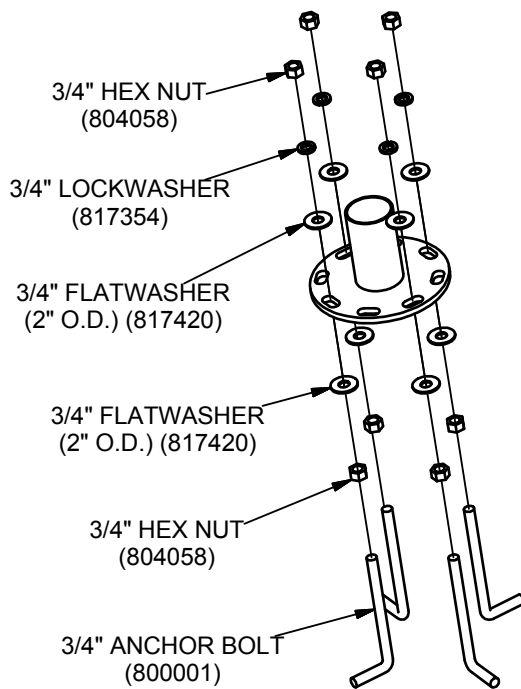

NOTE:
 - RESILIENT SURFACING AND SUBSTANTIAL COMPACTED SUBGRADE DEPTHS DEPEND ON SOIL CONDITIONS AND RESILIENT SURFACING TYPE.
 -SLOPED FOOTING IS A REQUIREMENT OF EUROPEAN STANDARD EN1176-1 ONLY.
 -SUGGESTED MINIMUM CONCRETE RATING 3000 PSI

**FOOTING ASSEMBLY DETAIL
 UP179J (FOOTING)**

Issued/Revised: 10/10/16



800.458.5872

www.ultraplay.com

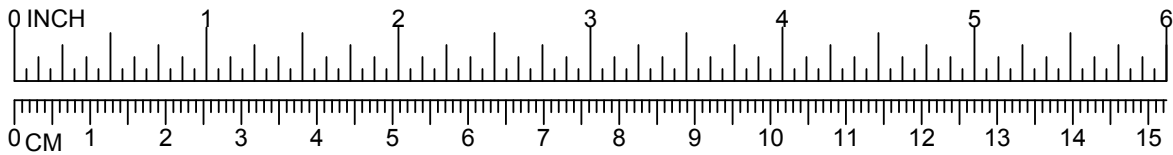

UP179J CHEST PRESS ACCESSIBLE (FOOTING) UP179S CHEST PRESS ACCESSIBLE (IN GROUND) UP179SM CHEST PRESS ACCESSIBLE (SURFACE)

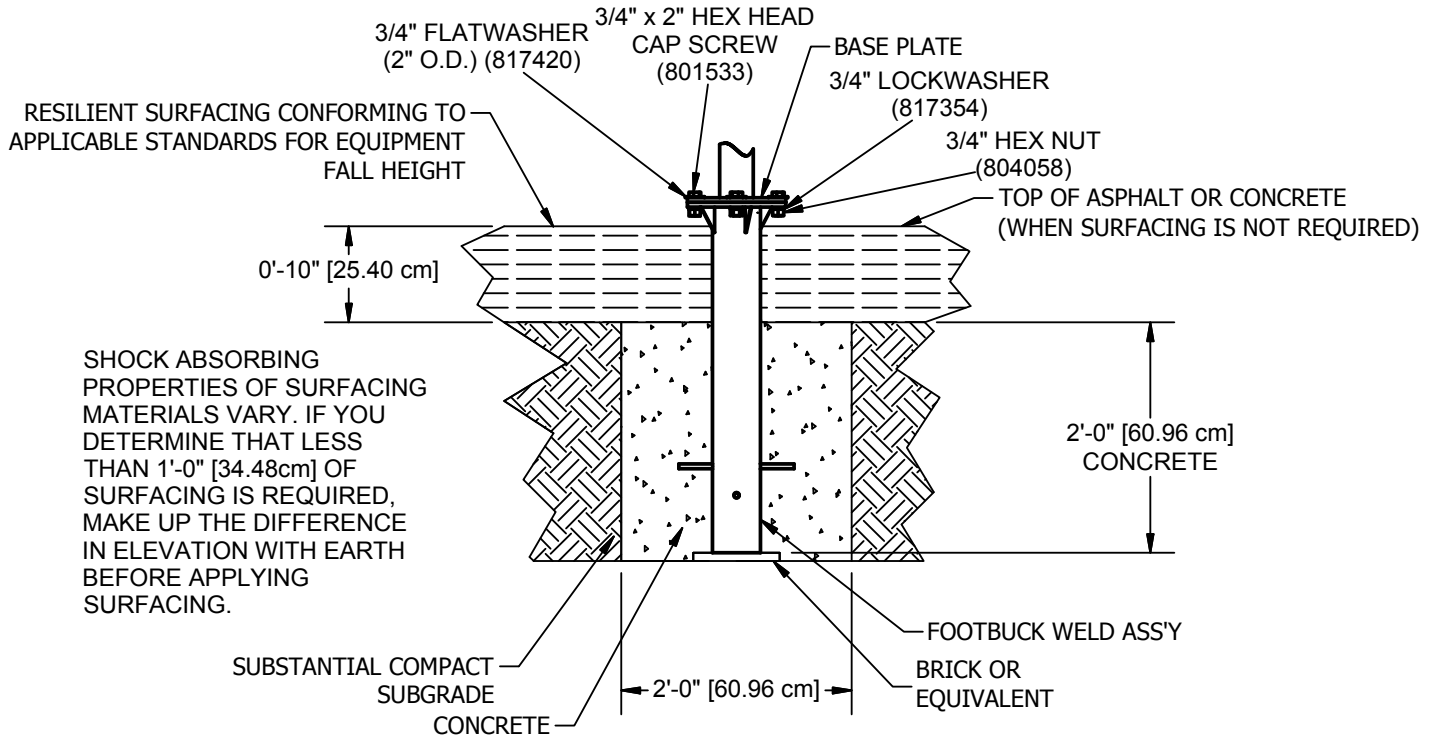

IN GROUND DETAIL

CONCRETE REQUIRED:

.30 CUBIC YARDS
 .23 CUBIC METERS

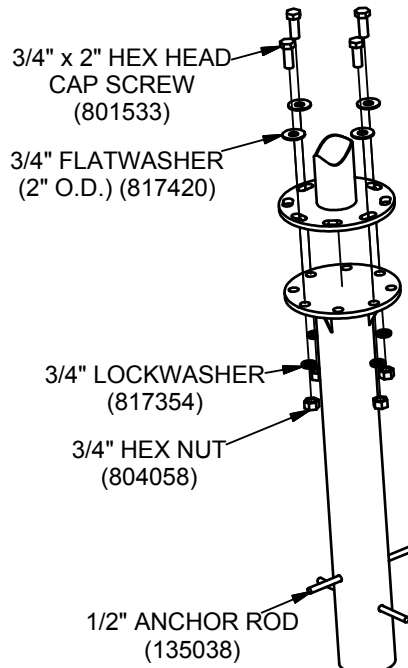

IN GROUND ASSEMBLY DETAIL UP179S (IN GROUND)

NOTE:

- RESILIENT SURFACING AND SUBSTANTIAL COMPACTED SUBGRADE DEPTHS DEPEND ON SOIL CONDITIONS AND RESILIENT SURFACING TYPE.
- SLOPED FOOTING (45° MIN) IS A REQUIREMENT OF EUROPEAN STANDARD EN1176-1 ONLY.
- SUGGESTED MINIMUM CONCRETE RATING 3000 PSI.

Issued/Revised: 10/10/16



A PLAYCORE Company

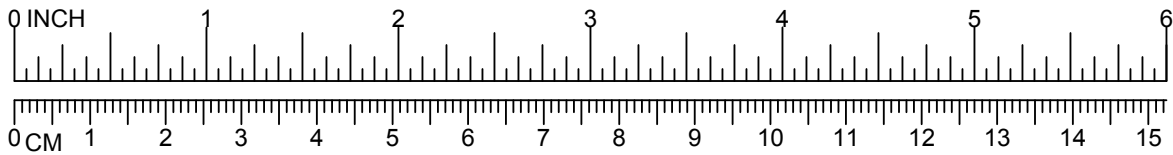

**UP179J CHEST PRESS ACCESSIBLE (FOOTING)
 UP179S CHEST PRESS ACCESSIBLE (IN GROUND)
 UP179SM CHEST PRESS ACCESSIBLE (SURFACE)**

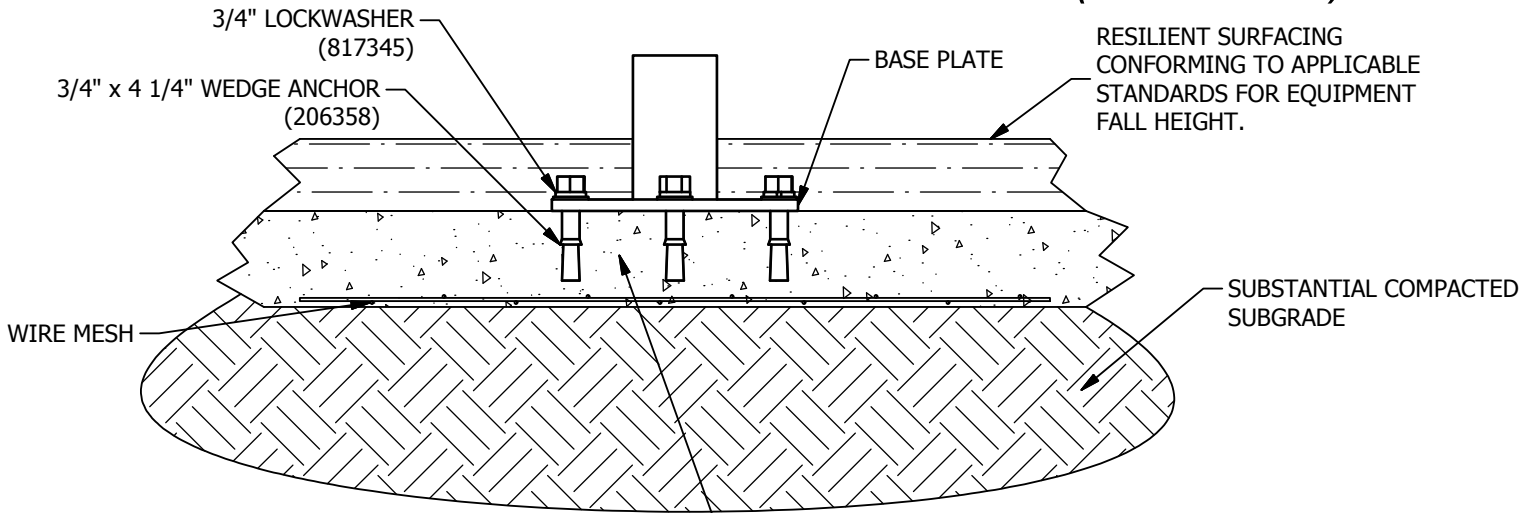

NOTE:
 - RESILIENT SURFACING AND SUBSTANTIAL COMPACTED SUBGRADE DEPTHS DEPEND ON SOIL CONDITIONS AND RESILIENT SURFACING TYPE.
 - SLOPED FOOTING IS A REQUIREMENT OF EUROPEAN STANDARD EN1176-1 ONLY.
 - SUGGESTED MINIMUM CONCRETE RATING 3000 PSI

EXISTING CONCRETE MUST BE MINIMUM 3,000 PSI, 4" MINIMUM DEPTH, WITH WIRE MESH REINFORCEMENT. MINIMUM 7 DAYS CURE-FULL CURE AFTER 28 DAYS.

**SURFACE DETAIL
 UP179SM (SURFACE)**

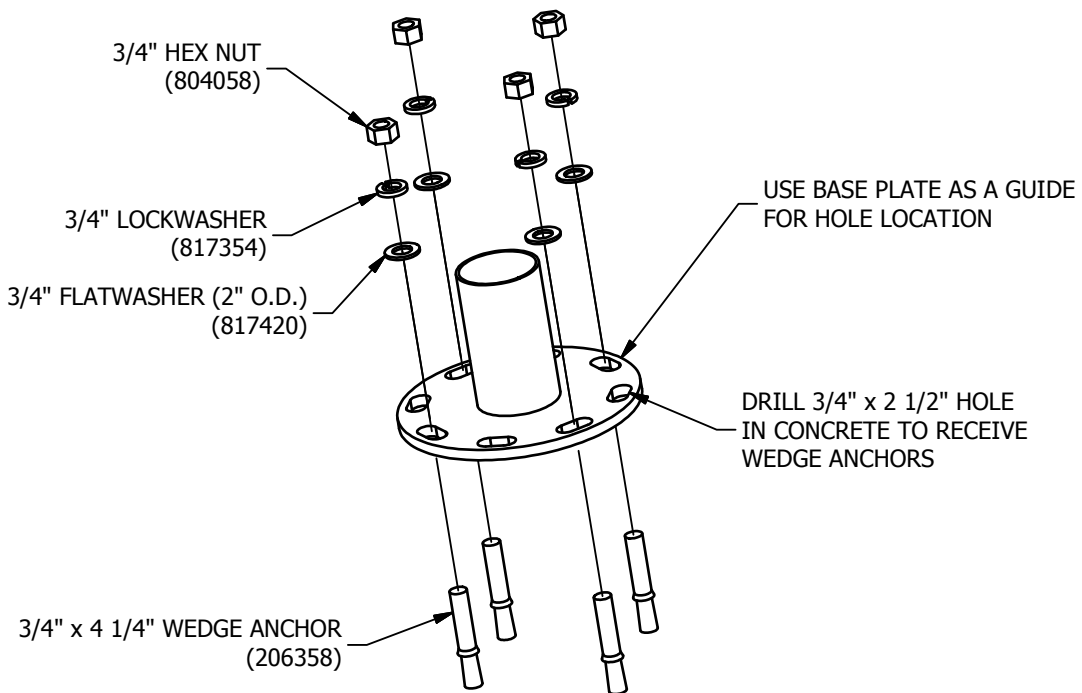

**SURFACE ASSEMBLY DETAIL
 UP179SM (SURFACE)**

Issued/Revised: 10/10/16



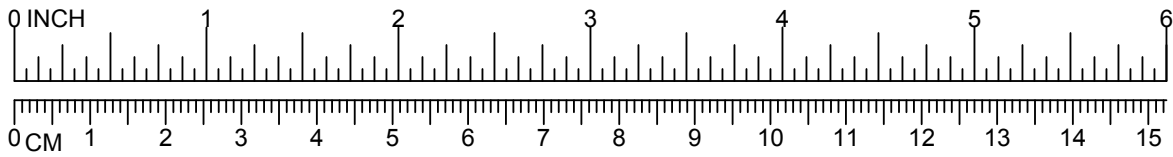

**UP179J CHEST PRESS ACCESSIBLE (FOOTING)
UP179S CHEST PRESS ACCESSIBLE (IN GROUND)
UP179SM CHEST PRESS ACCESSIBLE (SURFACE)**

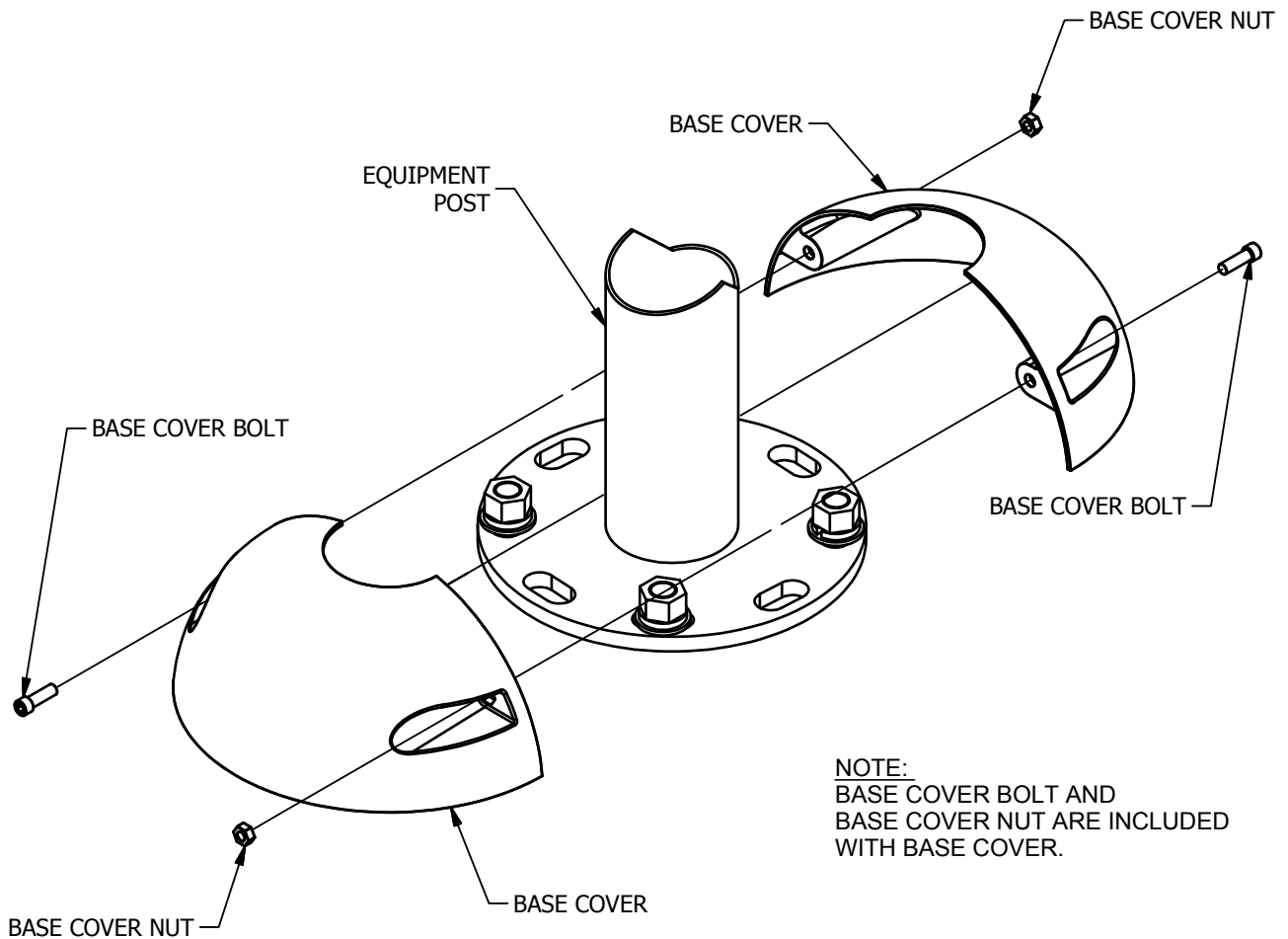

NOTE:
BASE COVER BOLT AND
BASE COVER NUT ARE INCLUDED
WITH BASE COVER.

BASE COVER DETAIL

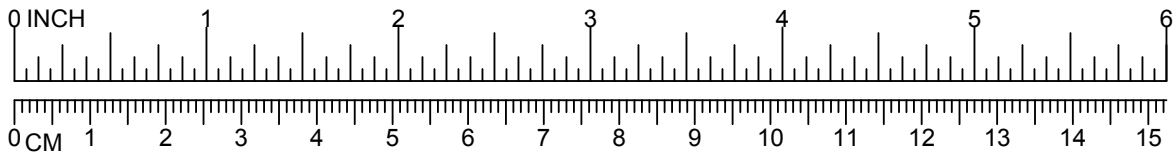

UP179J CHEST PRESS ACCESSIBLE (FOOTING)
UP179S CHEST PRESS ACCESSIBLE (IN GROUND)
UP179SM CHEST PRESS ACCESSIBLE (SURFACE)

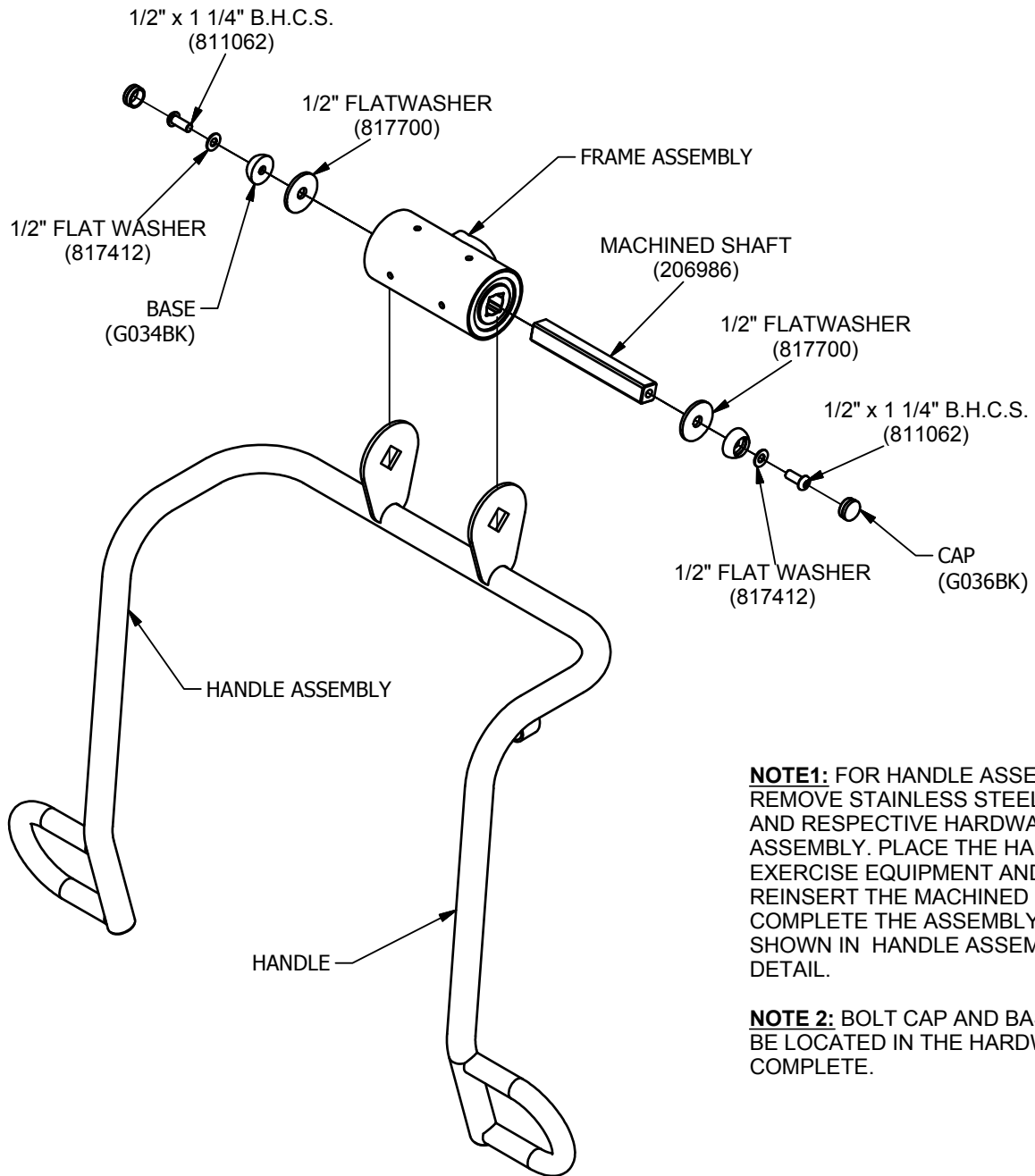

NOTE 1: FOR HANDLE ASSEMBLY, REMOVE STAINLESS STEEL SHAFT AND RESPECTIVE HARDWARE FROM ASSEMBLY. PLACE THE HANDLE ON EXERCISE EQUIPMENT AND REINSERT THE MACHINED SHAFT. COMPLETE THE ASSEMBLY AS SHOWN IN HANDLE ASSEMBLY DETAIL.

NOTE 2: BOLT CAP AND BASE WILL BE LOCATED IN THE HARDWARE COMPLETE.

ADA HANDLE ASSEMBLY DETAIL

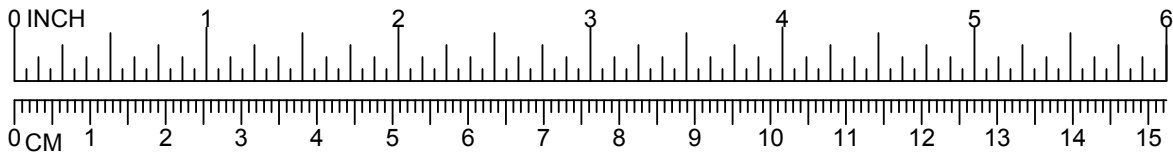

**UP179J CHEST PRESS ACCESSIBLE (FOOTING)
 UP179S CHEST PRESS ACCESSIBLE (IN GROUND)
 UP179SM CHEST PRESS ACCESSIBLE (SURFACE)**

