

**UP170J LEG PRESS (FOOTING)
UP170S LEG PRESS (IN GROUND)
UP170M LEG PRESS (SURFACE MOUNT)**

Parts List				
DESCRIPTION	UP170J (FOOTING)	UP170S (IN-GROUND)	UP170M (SURFACE MOUNT)	PART NUMBER
POST ASSEMBLY	1	1	1	403732
SEAT WELD ASS'Y	1	1	1	211500
ADA SEAT/BACKREST	2	2	2	207600
FOOTHOLD	2	2	2	403708
5" BASE COVER	1	1	1	207659
FOOTBUCK WELD ASS'Y	0	1	0	206467
HARDWARE COMPLETE	0	0	1	403943
HARDWARE COMPLETE	1	0	0	403941
HARDWARE COMPLETE	0	1	0	403942
3/4" HEX NUT	8	4	0	804058*
3/4" FLATWASHER (2" O.D.)	8	4	0	817420*
3/4" LOCKWASHER	4	4	4	817354*
3/4" x 2" HEX HEAD CAP SCREW	0	4	0	801533*
1/2" ANCHOR ROD	0	2	0	135038*
1/2" FLATWASHER	2	2	2	817700*
1/2" x 1 1/4" B.H.C.S.	2	2	2	811062*
3/8" LOCKWASHER	12	12	14	817334*
3/8" FLAT WASHER	8	8	8	817410*
3/8" x 3/4" P.B.H.C.S. w/PATCH	8	8	14	812052*
3/8" FLAT WASHER (1" O.D.)	4	4	6	817401*
3/4" WEDGE ANCHOR	0	0	4	206358*
3/4" ANCHOR BOLT	4	0	0	800001*
1/2" FLAT WASHER	2	2	2	817412*
12MM DO-NUT BASE	2	2	2	G034BK*
12MM DO-NUT CAP	2	2	2	G036BK*
SPACER PLATE	2	2	2	211597*
5" INJECTION MOLDED CAP	1	1	1	207710*
USAGE/WARNING LABEL	1	1	1	403892*

Unless Otherwise Specified, All Units of Measure are Each

Items listed below Hardware Complete line are included with Hardware Complete Number

Warning: During Installation, Hardware And Small Parts Are Choking Hazards For Young Children. Store Unused Parts Appropriately Until Assembly Is Completed. Once Assembly Is Completed, Remove Any Unused Parts From The Play Environment And Dispose/Save Them In A Secure Location. Any bolt end protruding more than two full threads beyond the face of the nut causes risk of clothing entanglement. Promptly cut-off flush, file smooth, and treat to prevent corrosion.

Note: Peen Tee-Nuts and Flatwashers to match radius of pipe after assembly is complete.

Note: Loctite (supplied by others) should be used on any non-patch hardware.

UP170J LEG PRESS (FOOTING) UP170S LEG PRESS (IN GROUND) UP170M LEG PRESS (SURFACE MOUNT)

SPECIFICATIONS:

BACKREST/SEAT: The Backrest and seat shall be constructed from injection molded Nylon W6.

BASE COVER: The Base Cover shall be constructed from aluminum and powder coated.

BOLT GUARD CAP AND BASE: The Bolt Guard shall be constructed from Nylon PA6, and shall be black in color.

FOOTHOLD: The Foothold shall be constructed of die cast aluminum and powder coated.

5" PLASTIC CAP: The 5" Plastic Cap shall be constructed from injection molded Low Density Polyethylene.

WELD ASSEMBLIES:

SEAT WELD ASSEMBLY: Shall be an all welded construction consisting of 2 3/8" O.D. Schedule 40 tubing, 3/8" Laser Cut Steel tab, 2 3/8" O.D. galvanized pipe, and a 1/8" thick hot rolled steel brace. Assembly shall have a powder coat finish.

POST ASSEMBLY: Leg Press assembly shall be manufactured with 3" I.D. x .300" extra strong black pipe, 3/8" x 1 1/2" hot rolled steel plate, 1/8" laser cut steel bracket, 14 gauge hot rolled galvanized steel pipe cap, 1/2" hot rolled steel mounting plate, 2 3/8" O.D. galvanized pipe, and 5" O.D. galvanized upright. The upright shall be 11 gauge (.120") galvanized round tubing, manufactured to ASTM A-500 Grade B tolerances from cold-formed steel conforming to ASTM A-569 Sheet Spec for steel coil. Minimum yield strength shall be 50,000 psi and minimum tensile strength shall be 55,000 psi. The exterior surface is hot dip galvanized, chromate conversion coated, and a clear high performance organic polymer is applied. The inside diameter has 81% minimum zinc rich primer capable of providing excellent rust protection and fabrication characteristics. All coatings are applied inside and out after welding for superior corrosion protection throughout. Exterior surface galvanizing zinc purity is 99% as per ASTM B-6 high grade and special high grade. Galvanizing coverage shall demonstrate the ability to exceed 1000 hours salt spray corrosion exposure in accordance with ASTM B-117. Internal surface zinc rich 81% minimum zinc dust content in organic resin, as per ASTM F-1234, Section 5.2.4, Type D. The main support frame assemblies and formed supports shall be coated with a custom formula of TGIC polyester powder, after fabrication in conformance with the specifications outlined herein.

MECHANISM PARTS:

STOP COG: Shall be manufactured with 3/8" laser cut steel.

DISK BEARING: The disk bearing should be pre lubricated 3 3/8" O.D. 1 1/8" square bore stainless steel bearing.

MACHINED SHAFT: The machine shaft shall be manufactured with 1 3/16" x 9 1/8" stainless steel shaft.

RUBBER SPRING: Shall consist of rubber encapsulated by cast steel with a steel inner core.

FOOTBUCK: The upright shall be fabricated of 5" O.D. galvanized pipe and the mounting plate shall be a fabricated 3/8" hot rolled flat steel. Shall be a once piece welded unit.

POWDER COAT FINISH: Shall be an electrostatically applied custom formula of TGIC polyester powder. All components will be free of sharp edges and excess weld spatter and shall be cleaned in a six stage bath system with an iron phosphate wash, as a rust inhibitor, and a sealer to prevent flash rusting before coating, The coating shall have a super tough finish with maximum exterior durability and will have superior adhesion characteristics. Typical Characteristics are: 3.0 - 5.0 mil thickness and oven cured between 375 to 425 degrees Fahrenheit. Pencil Hardness H (ASTM D-3363), Impact (ASTM D-2794-69), Wedge Bend (ASTM D-522-68).

HARDWARE: All nuts, bolts, screws, and lock washers used in the assembly shall be stainless steel, yellow dichromate plated steel, blue-coat plated steel, mechanically galvanized or powder coated/yellow dichromate plated steel. All primary fasteners shall be 304 alloy stainless steel. Fasteners with yellow dichromate treatment have an electro-deposited, 99.9% pure zinc substrate applied from a specially formulated solution sealed with a yellow dichromate top coat designed to work in conjunction with the zinc plating.

UP170J LEG PRESS (FOOTING) UP170S LEG PRESS (IN GROUND) UP170M LEG PRESS (SURFACE MOUNT)

NOTE: Do not overtighten bolts. To overtighten may cause buckling or dimpling of some parts.

NOTE: Read installation instructions thoroughly before starting assembly. Pour concrete only after final assembly is completed. Bracing material is required during assembly.

NOTE: Assembly and leveling times will be greatly reduced if a transit is used to set location and depth of ground holes.

INSTALLATION INSTRUCTIONS FOR UP170J (FOOTING):

1. Attach Seat to frame using 3/8" x 3/4" P.B.H.C.S w/ Patch, 3/8" Lockwasher and 3/8" Flatwasher. See Seat Detail. Attach Foothold to Frame using 3/8" x 3/4" P.B.H.C.S. w/ Patch, 3/8" Lockwasher, 3/8" Flatwasher, and Filler Plate. See Foothold Detail. Insert Injection Molded Cap, refer to Cap Detail.
2. Attach Chair Pipe Ass'y to Main Post Ass'y using 1/2" x 1 1/4" B.H.C.S, 1/2" Flatwashers, and Bolt Guard Caps and Bases. See Leg Press Ass'y Detail.
3. Dig holes or drill holes according to Plan View and Elevation View. **NOTE:** Due to extremes in weather and soil conditions, hole size may have to be increased to meet local conditions.
4. Fill hole with concrete. While the concrete is still soft, yet firm enough to support the Leg Press, Place (4) Anchor Bolts of the Leg Press in position. See Footing Detail. **NOTE:** Use Leg Press as a template for Anchor Bolt location, then remove Leg Press.

IMPORTANT: DO NOT MOUNT THE LEG PRESS TO THE ANCHOR BOLTS FOR AT LEAST 7 DAYS.

5. After concrete has cured and set for a minimum of 7 Days, attach Leg Press to 3/4" Anchor Bolt using 3/4" Flat Washer (2" O.D.), 3/4" Lock Washer, and 3/4" Hex Nut. See Footing Assembly Detail.
6. Attach Base Cover to Equipment Post using Base Cover Nut and Base Cover Bolt included with Base Cover. See Base Cover Detail.

INSTALLATION INSTRUCTIONS FOR UP170S (IN-GROUND):

1. Attach Seat to frame using 3/8" x 3/4" P.B.H.C.S w/ Patch, 3/8" Lockwasher and 3/8" Flatwasher. See Seat Detail. Attach Foothold to Frame using 3/8" x 3/4" P.B.H.C.S. w/ Patch, 3/8" Lockwasher, 3/8" Flatwasher, and Filler Plate. See Foothold Detail. Insert Injection Molded Cap, refer to Cap Detail.
2. Attach Chair Pipe Ass'y to Main Post Ass'y using 1/2" x 1 1/4" B.H.C.S, 1/2" Flatwashers, and Bolt Guard Caps and Bases. See Leg Press Ass'y Detail.
3. Dig holes or drill holes according to Plan View and Elevation View. **NOTE:** Due to extremes in weather and soil conditions, hole size may have to be increased to meet local conditions.
4. Attach the Footbuck Weld Assembly to the Leg Press using 3/4" Hex Nut, 3/4" Lockwasher, 3/4" Flatwasher (2" O.D.), 3/4" x 2" Hex Head Cap Screw. See In-Ground Assembly Detail.
5. Place Leg Press into hole making sure it rests on the brick. See In-Ground Detail.
6. Level Leg Press using sway bracing.
7. Pour concrete according to the Plan View and Elevation View. Allow concrete to cure for a minimum of 7 days.
8. Attach Base Cover to Equipment Post using Base Cover Detail.

Issued/Revised: 10/14/16

**UP170J LEG PRESS (FOOTING)
UP170S LEG PRESS (IN GROUND)
UP170M LEG PRESS (SURFACE MOUNT)**

INSTALLATION INSTRUCTIONS FOR UP170M (SURFACE MOUNT):

1. Attach Seat to frame using 3/8" x 3/4" P.B.H.C.S w/ Patch, 3/8" Lockwasher and 3/8" Flatwasher. See Seat Detail. Attach Foothold to Frame using 3/8" x 3/4" P.B.H.C.S. w/ Patch, 3/8" Lockwasher, 3/8" Flatwasher, and Filler Plate. See Foothold Detail. Insert Injection Molded Cap, refer to Cap Detail.
2. Attach Chair Pipe Ass'y to Main Post Ass'y using 1/2" x 1 1/4" B.H.C.S, 1/2" Flatwashers, and Bolt Guard Caps and Bases. See Leg Press Ass'y Detail.
3. Mark correct location of holes for Wedge Anchor using the Base Plate as a guide.
4. Drill 3/4" x 2 1/2" hole in concrete for Wedge Anchor. See Surface Detail.
5. Insert Wedge Anchors and secure with 3/4" Flatwasher (2" O.D.), 3/4" Lockwasher, and 3/4" Hex Nut. See Surface Assembly Detail.
6. Attach Base Cover to Equipment Post using Base Cover Detail.

MAINTENANCE PROCEDURE:

Periodically check hardware for tightness, and tighten as necessary. Always check all parts for breakage or wear, and immediately put equipment out of service until any faulty parts found are repaired or replaced. Also Check all metal parts for rust, paint loss and touch-up if necessary with paint. Check for welded areas and verify integrity. Check periodically resilient surfacing for appropriate depth and remove extraneous materials that could cause injury, infection, or disease. Maintain detailed installation, inspection, maintenance, and repair records for each public-use playground equipment.

UP170J LEG PRESS (FOOTING)
UP170S LEG PRESS (IN GROUND)
UP170M LEG PRESS (SURFACE MOUNT)

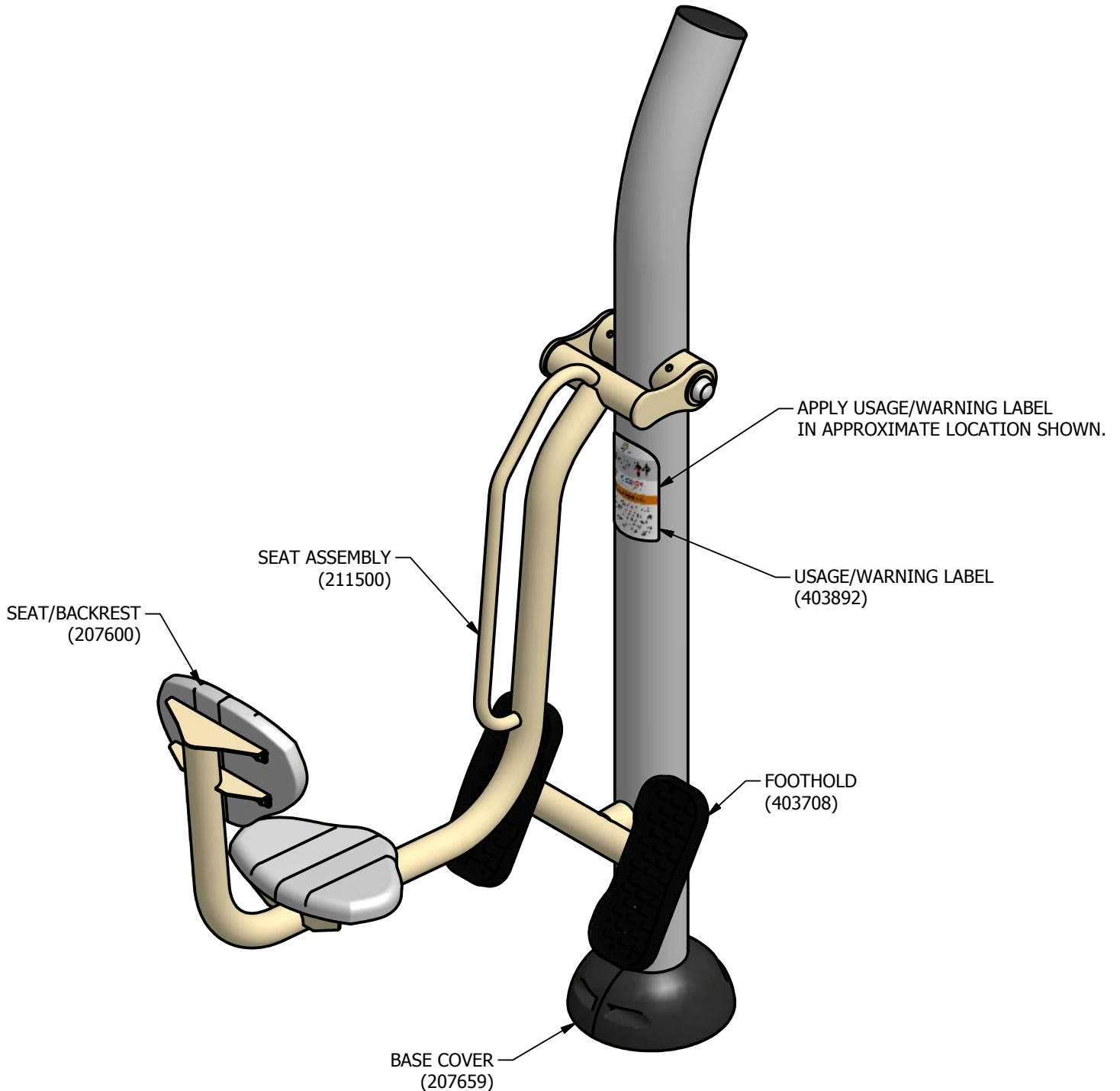

FINISHED ASSEMBLY

Issued/Revised: 10/14/16

800.458.5872



www.actionfitoutdoors.com

**UP170J LEG PRESS (FOOTING)
UP170S LEG PRESS (IN GROUND)
UP170M LEG PRESS (SURFACE MOUNT)**

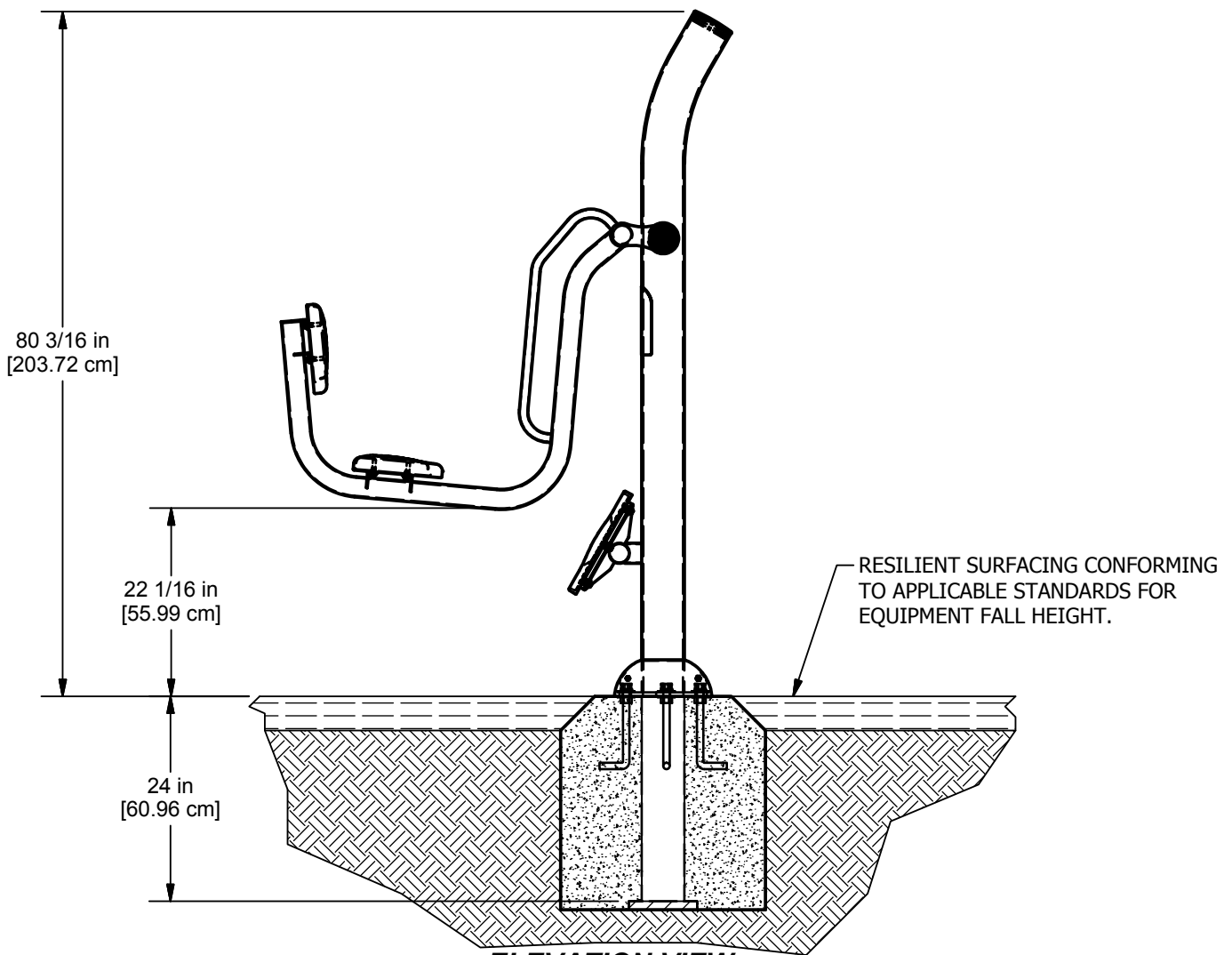
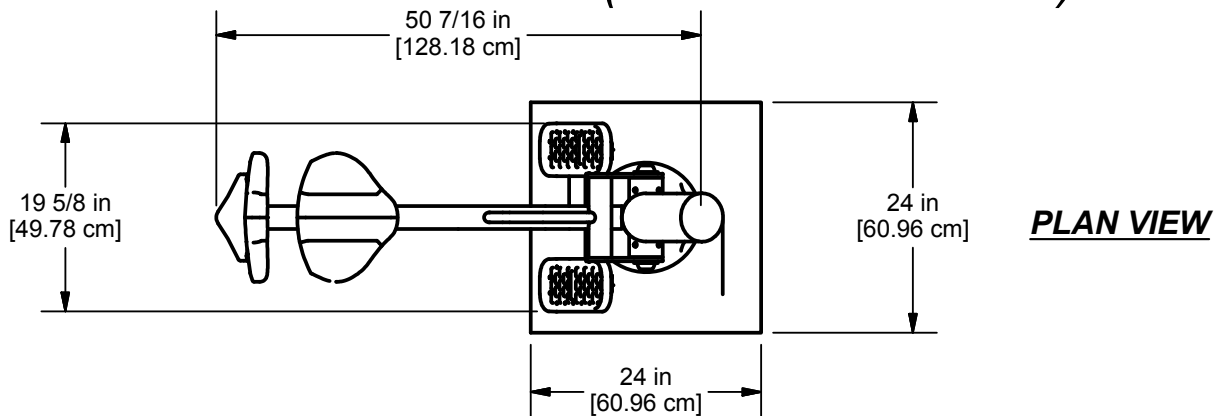

UP170J (FOOTING)

Issued/Revised: 10/14/16

**UP170J LEG PRESS (FOOTING)
UP170S LEG PRESS (IN GROUND)
UP170M LEG PRESS (SURFACE MOUNT)**

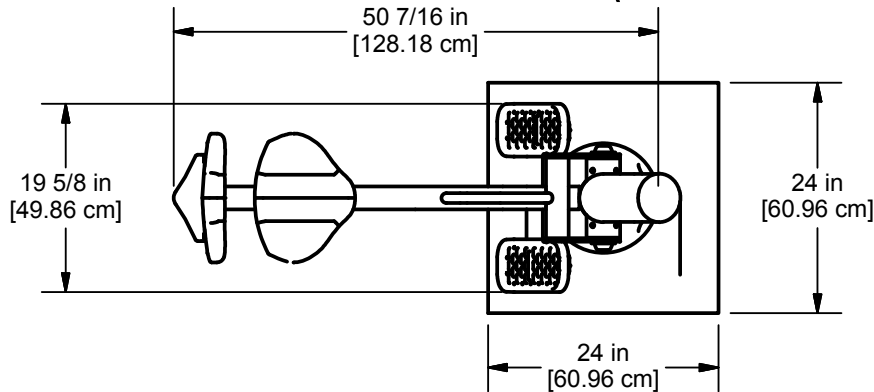

PLAN VIEW

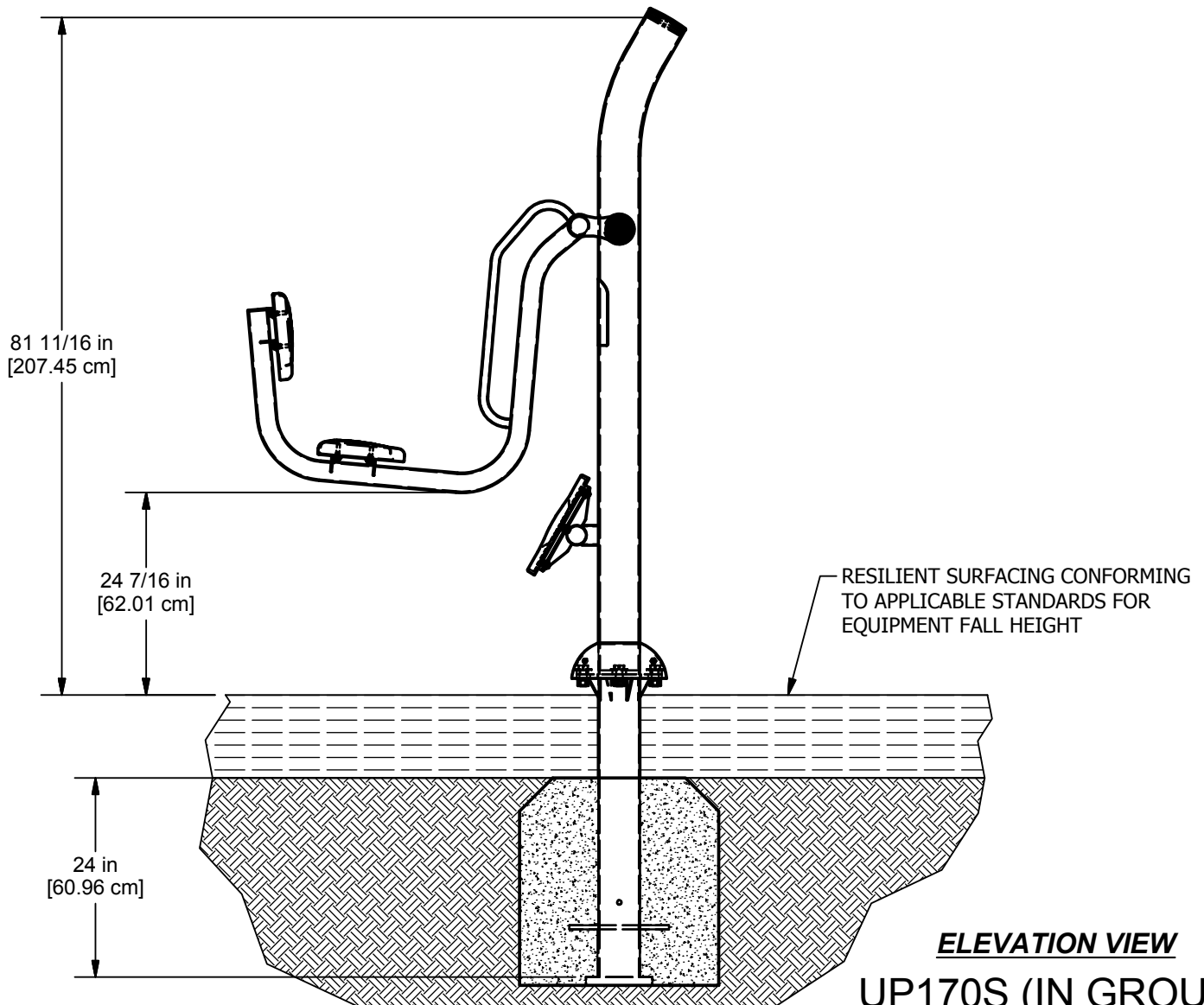

ELEVATION VIEW

UP170S (IN GROUND)

Issued/Revised: 10/14/16



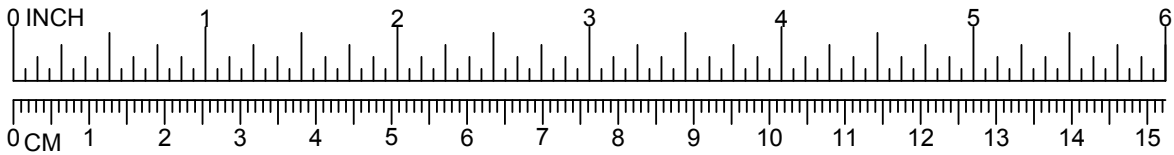

**UP170J LEG PRESS (FOOTING)
 UP170S LEG PRESS (IN GROUND)
 UP170M LEG PRESS (SURFACE MOUNT)**

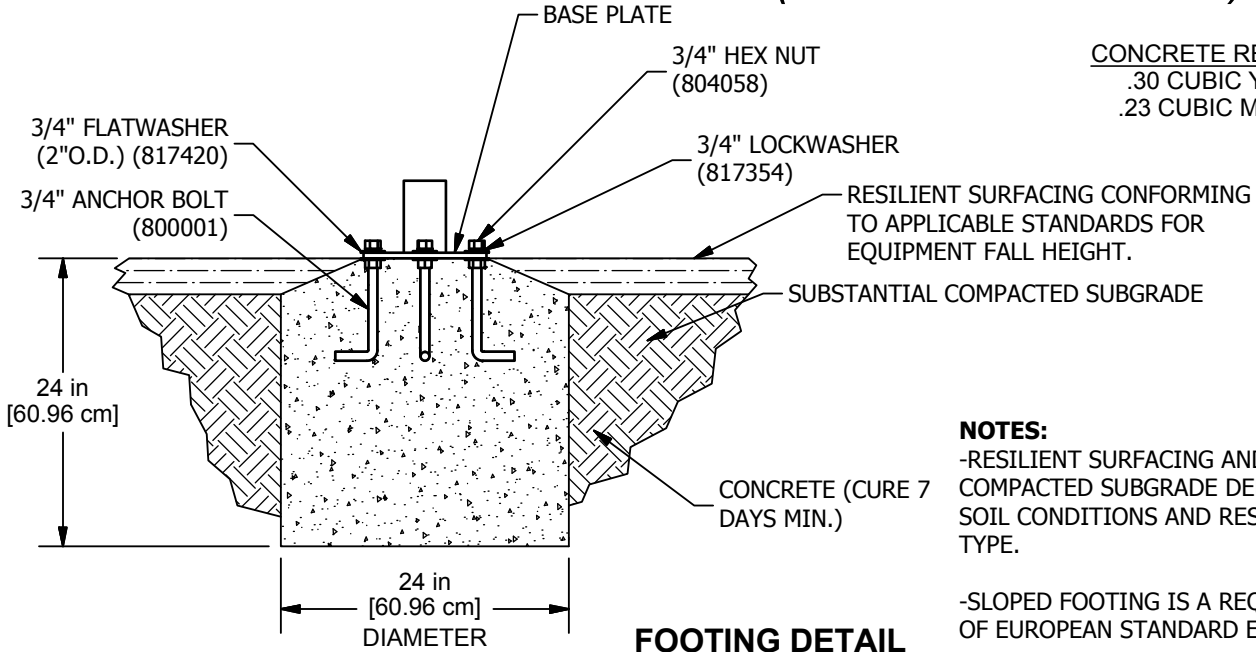

CONCRETE REQUIRED:
 .30 CUBIC YARDS
 .23 CUBIC METERS

- NOTES:**
- RESILIENT SURFACING AND SUBSTANTIAL COMPACTED SUBGRADE DEPTHS DEPEND ON SOIL CONDITIONS AND RESILIENT SURFACING TYPE.
 - SLOPED FOOTING IS A REQUIREMENT OF EUROPEAN STANDARD EN1176-1 ONLY
 - SUGGESTED MINIMUM CONCRETE RATING 3000 PSI.

FOOTING DETAIL

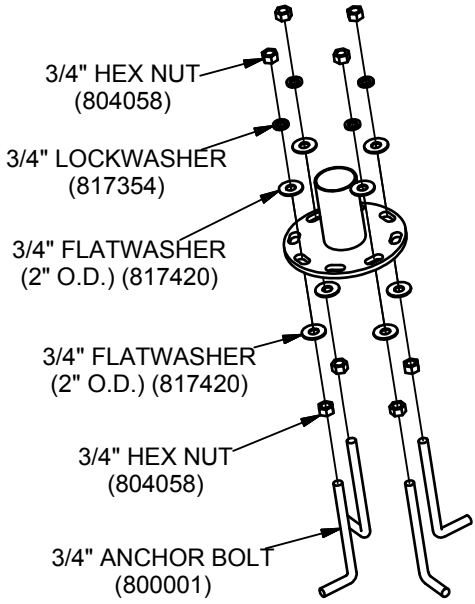

**FOOTING ASSEMBLY DETAIL
 UP170J (FOOTING)**

Issued/Revised: 10/14/16



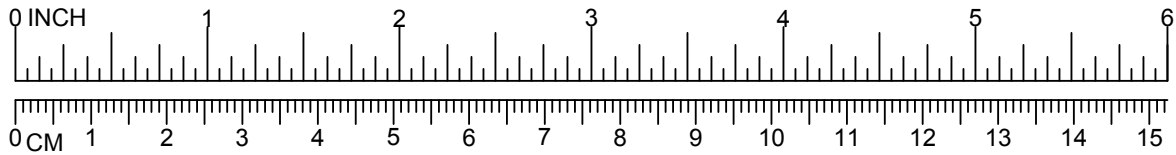

UP170J LEG PRESS (FOOTING) UP170S LEG PRESS (IN GROUND) UP170M LEG PRESS (SURFACE MOUNT)

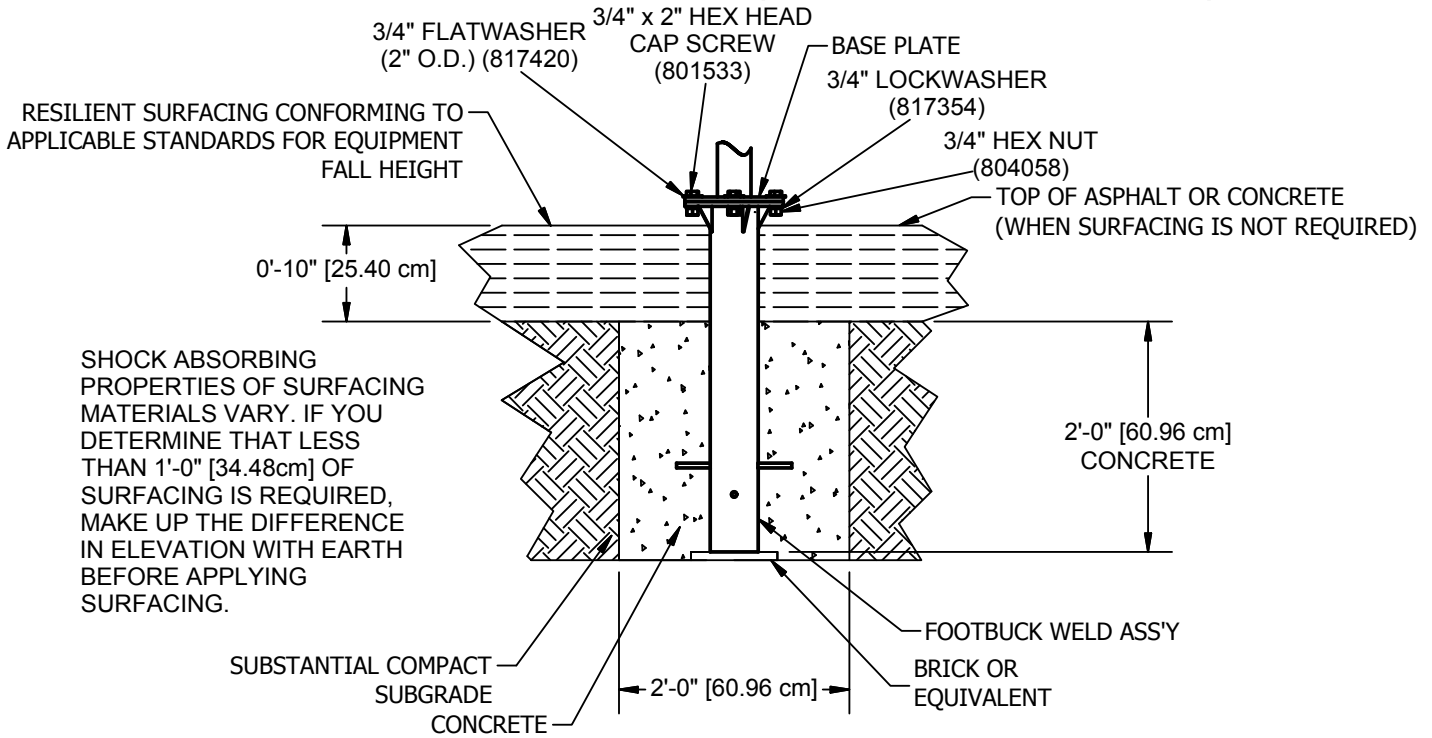

IN GROUND DETAIL

CONCRETE REQUIRED:

.30 CUBIC YARDS
.23 CUBIC METERS

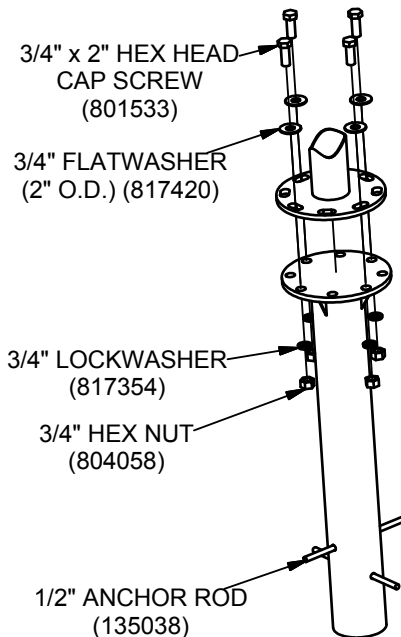

IN GROUND ASSEMBLY DETAIL UP170S (IN GROUND)

NOTE:

- RESILIENT SURFACING AND SUBSTANTIAL COMPACTED SUBGRADE DEPTHS DEPEND ON SOIL CONDITIONS AND RESILIENT SURFACING TYPE.
- SLOPED FOOTING (45° MIN) IS A REQUIREMENT OF EUROPEAN STANDARD EN1176-1 ONLY.
- SUGGESTED MINIMUM CONCRETE RATING 3000 PSI.

Issued/Revised: 10/14/16



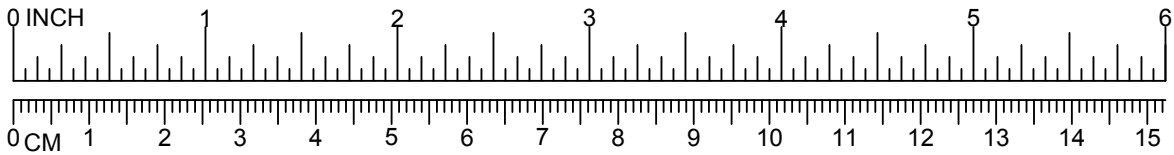

**UP170J LEG PRESS (FOOTING)
 UP170S LEG PRESS (IN GROUND)
 UP170M LEG PRESS (SURFACE MOUNT)**

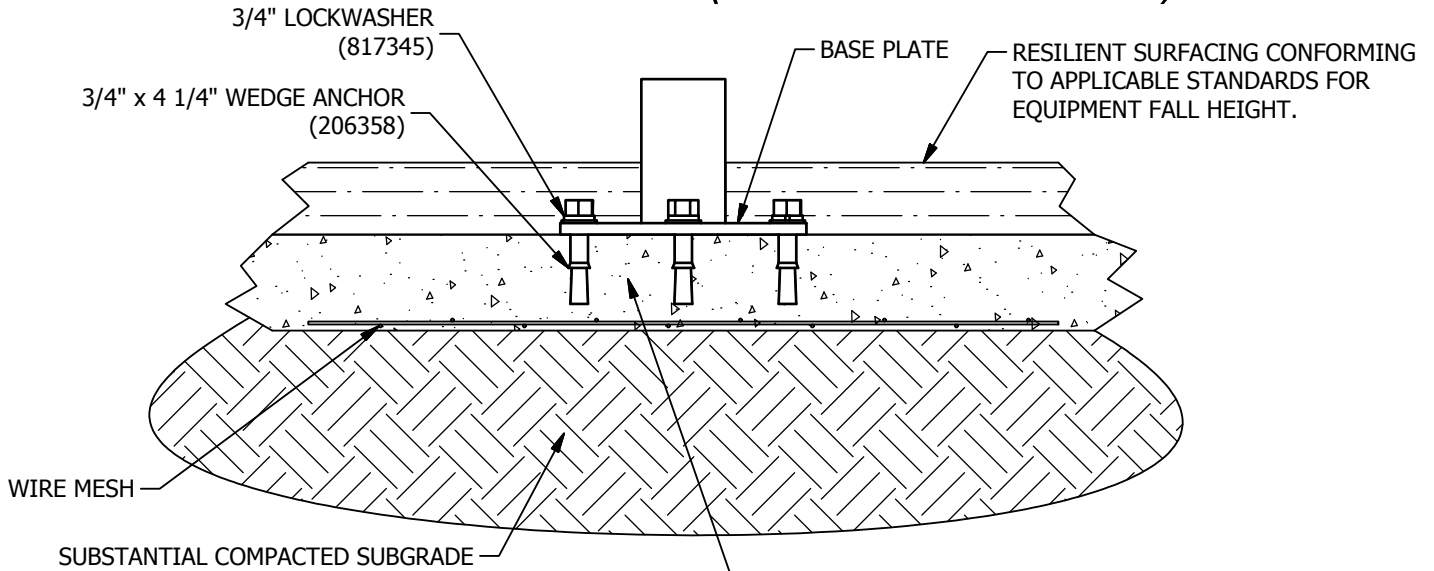

NOTES:
 -LOOSE FILL SURFACING NOT RECOMMENDED FOR SURFACE MOUNT.
 EXISTING CONCRETE MUST BE MINIMUM 3,000 PSI, 4\"/>

SURFACE DETAIL

-RESILIENT SURFACING AND SUBSTANTIAL COMPACTED SUBGRADE DEPTHS DEPEND ON SOIL CONDITIONS AND RESILIENT SURFACING TYPE.

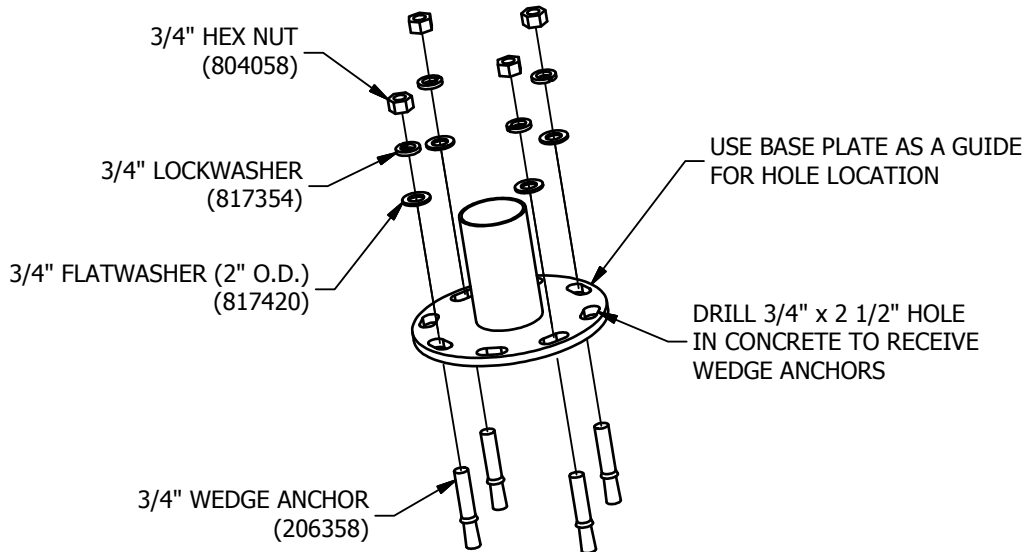

**SURFACE ASSEMBLY DETAIL
 UP170M (SURFACE MOUNT)**

Issued/Revised: 10/14/16



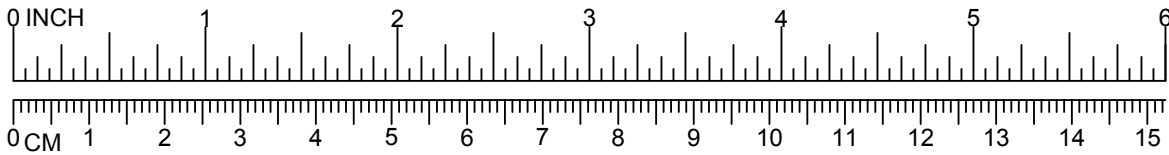

**UP170J LEG PRESS (FOOTING)
UP170S LEG PRESS (IN GROUND)
UP170M LEG PRESS (SURFACE MOUNT)**

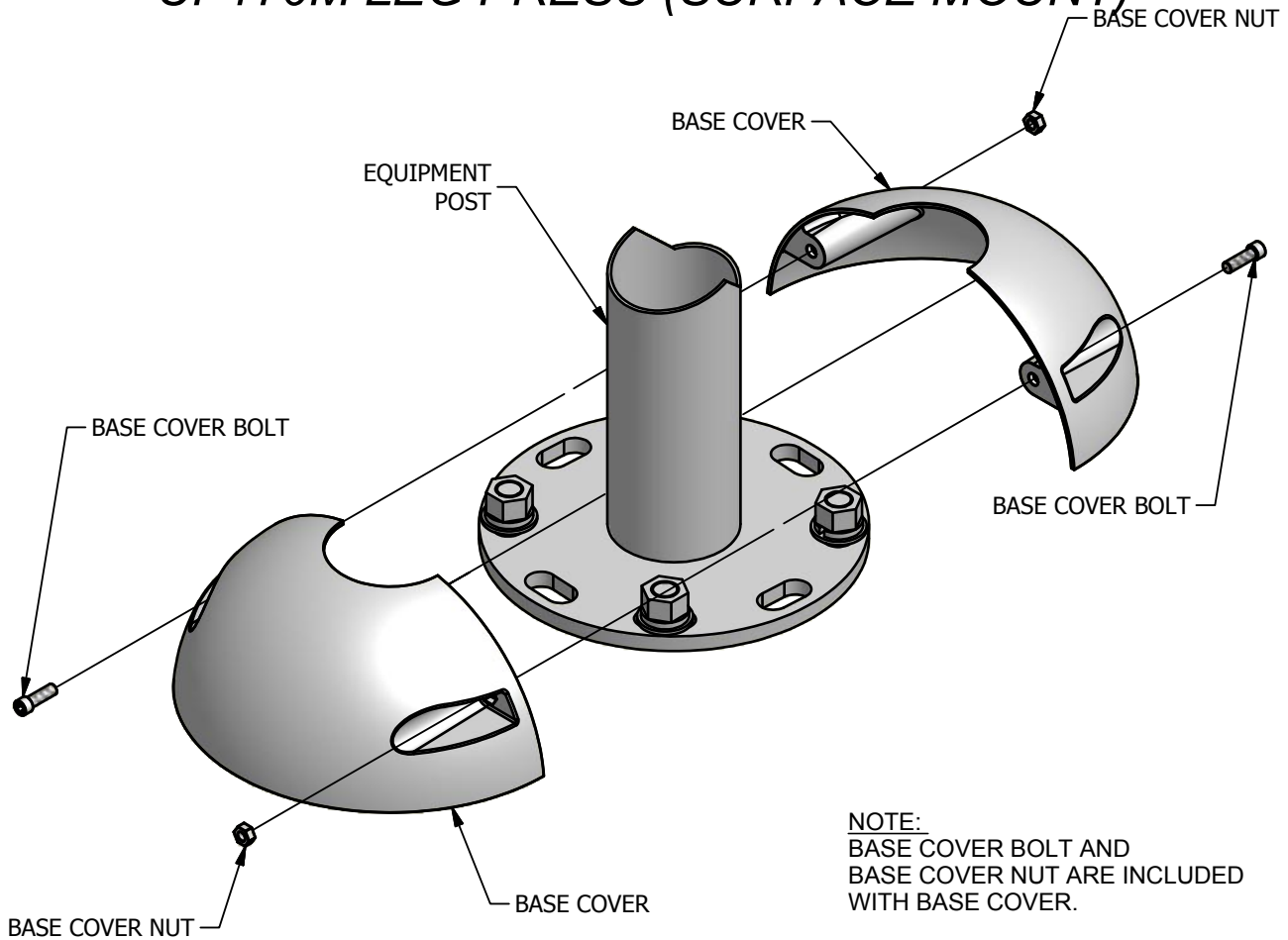

NOTE:
BASE COVER BOLT AND
BASE COVER NUT ARE INCLUDED
WITH BASE COVER.

BASE COVER DETAIL



UP170J LEG PRESS (FOOTING) UP170S LEG PRESS (IN GROUND) UP170SM LEG PRESS (SURFACE)

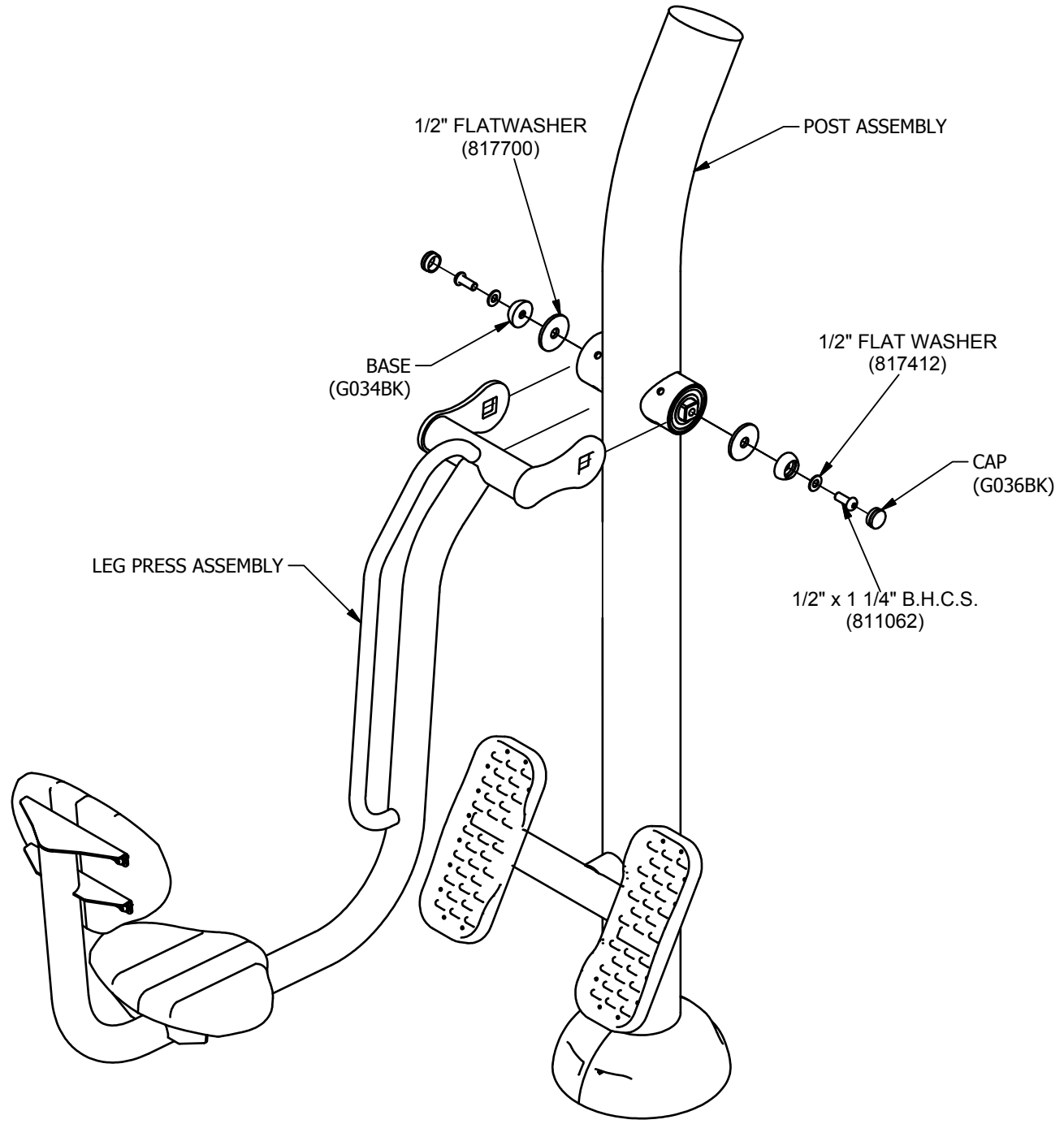

LEG PRESS ASS'Y DETAIL

Issued/Revised: 10/14/16



800.458.5872

www.ultraplay.com



**UP170J LEG PRESS (FOOTING)
 UP170S LEG PRESS (IN GROUND)
 UP170M LEG PRESS (SURFACE MOUNT)**

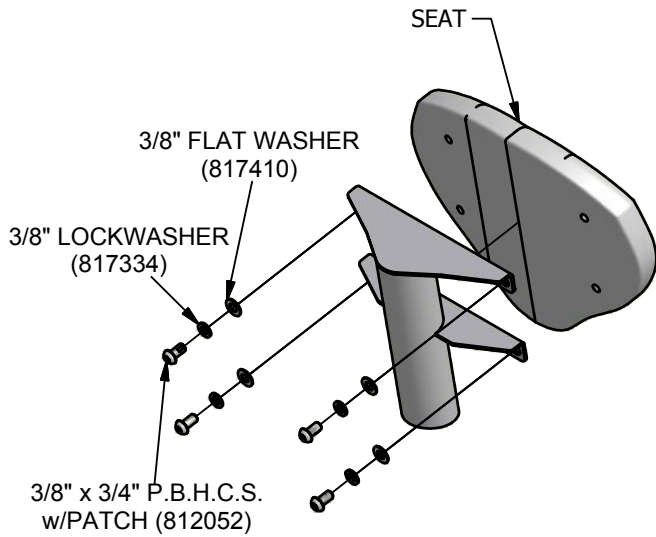

SEAT DETAIL

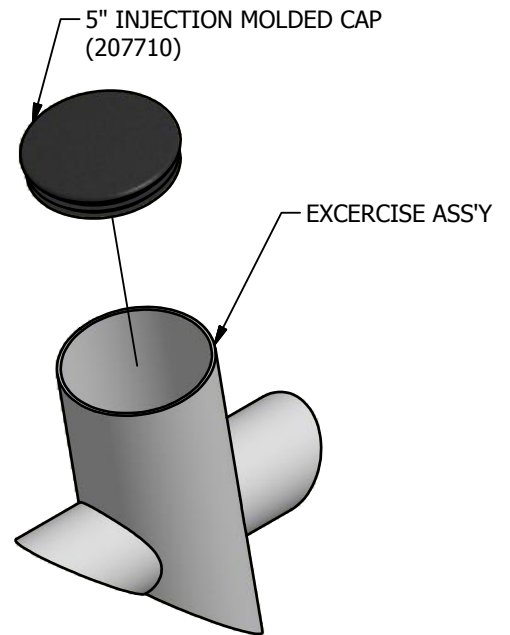

CAP DETAIL

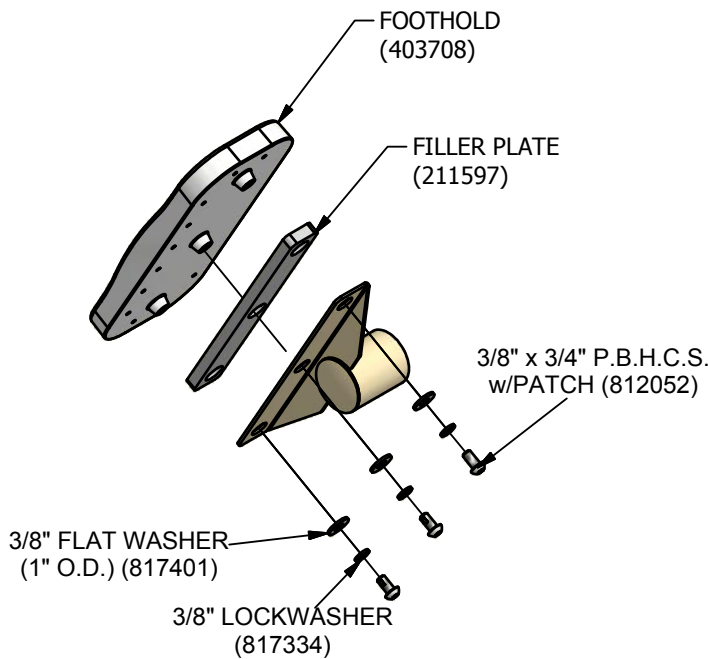

FOOTHOLD DETAIL

Issued/Revised: 10/14/16

800.458.5872



www.ultraplay.com