

**UP168J SIT-UP/BACK EXTENSION (FOOTING)  
UP168S SIT-UP/BACK EXTENSION (IN GROUND)  
UP168M SIT-UP/BACK EXTENSION (SURFACE MOUNT)**

Parts List				
DESCRIPTION	UP168J (FOOTING)	UP168S (IN GROUND)	UP168M (SURFACE MOUNT)	PART NUMBER
UPRIGHT ASSEMBLY	1	1	1	211227
BACK EXTENSION ASSEMBLY	1	1	1	211230
SIT-UP BENCH ASSEMBLY	1	1	1	211242
CUSHION	2	2	2	209075
COATED METAL INSERT	1	1	1	211506
5" BASE COVER	1	1	1	207659
3 1/2" DOME CAP	8	8	8	211492
FOOTBUCK WELD ASS'Y	0	1	0	206467
SUPPORT FOOTBUCK WELD ASS'Y	0	2	0	206759
<b>HARDWARE COMPLETE</b>	1	0	0	403938
<b>HARDWARE COMPLETE</b>	0	1	0	403939
<b>HARDWARE COMPLETE</b>	0	0	1	403940
5" INJECTION MOLDED CAP	1	1	1	207710*
3/16" x 13/32" DRIVE RIVET	16	16	16	805366*
1/2" x 4" HEX HEAD BOLT	3	3	3	801224*
1/2" LOCKWASHER	3	7	3	817342*
1/2" HEX NUT	7	7	3	804055*
3/8" FLAT WASHER	16	16	16	817410*
3/8" LOCKWASHER	8	8	8	817334*
3/8" x 3/4" P.B.H.C.S. w/PATCH	8	8	8	812052*
3/4" WEDGE ANCHOR	0	0	4	206358*
3/4" LOCKWASHER	4	4	4	817354*
1/2" x 4 1/4" WEDGE ANCHOR	0	0	4	800082*
3/4" ANCHOR BOLT	4	0	0	800001*
3/4" HEX NUT	8	4	0	804058*
3/4" FLATWASHER (2" O.D.)	8	4	0	817420*
1/2" ANCHOR BOLT	4	0	0	800000*
5/8" S.S FLATWASHER	4	0	0	817415*
1/2" ANCHOR ROD	0	2	0	135038*
3/4" x 2" HEX HEAD CAP SCREW	0	4	0	801533*
1/2" x 2 1/2" HEX BOLT	0	4	0	801207*
3/8" x 3/4" CARRIAGE BOLT	8	8	8	800252*

CONT'D ON NEXT PAGE

## UP168J SIT-UP/BACK EXTENSION (FOOTING) UP168S SIT-UP/BACK EXTENSION (IN GROUND) UP168M SIT-UP/BACK EXTENSION (SURFACE MOUNT)

Parts List				
DESCRIPTION	UP168J (FOOTING)	UP168S (IN GROUND)	UP168M (SURFACE MOUNT)	PART NUMBER
3/8" LOCK NUT	8	8	8	804353*
1/2" LOCK NUT	4	0	4	804355*
1/2" FLAT WASHER	10	10	10	817412*
12MM DO-NUT BASE	10	10	10	G034BK*
12MM DO-NUT CAP	10	10	10	G036BK*
USAGE/WARNING LABEL	1	1	1	403888*

*Unless Otherwise Specified, All Units of Measure are Each*

*\*Items listed below Hardware Complete line are included with Hardware Complete Number*

**Warning: During Installation, Hardware And Small Parts Are Choking Hazards For Young Children. Store Unused Parts Appropriately Until Assembly Is Completed. Once Assembly Is Completed, Remove Any Unused Parts From The Play Environment And Dispose/Save Them In A Secure Location. Any bolt end protruding more than two full threads beyond the face of the nut causes risk of clothing entanglement.**

**Promptly cut-off flush, file smooth, and treat to prevent corrosion.**

**Note: Peen Tee-Nuts and Flatwashers to match radius of pipe after assembly is complete.**

**Note: Loctite (supplied by others) should be used on any non-patch hardware.**

### SPECIFICATIONS

**BASE COVER:** The Base Cover shall be constructed from aluminum and powder coated.

**BOLT COVER BASE AND CAP:** The Bolt Cover Base and Cap shall be constructed from Nylon PA6 and shall be black in color.

**CUSHION:** The Cushion shall be constructed from injection molded Nylon W6.

**POST CAP:** The Post Cap shall be constructed from injection molded Polyethylene.

**UPRIGHT ASSEMBLY:** The main frame shall be an all welded assembly fabricated from 5" O.D. 7 Gauge Tubing and a 1/4" thick steel plate. Assembly shall be powdercoated after welding.

**SIT-UP BENCH FRAME:** Shall be an all welded assembly constructed from 3 1/2" O.D. Galvanized pipe, 2 3/8" O.D. Sch. 40 Pipe, and 1.66" O.D. Sch. 40 Pipe. Frame will attach to Upright with a 1/4" Thick Formed Steel Tab. Frame shall be powdercoated after welding.

**BACK EXTENSION FRAME:** Shall be an all welded assembly constructed from 3 1/2" O.D. Galvanized pipe and 2 3/8" O.D. Sch. 40 Pipe. Frame will attach to Upright with a 1/4" Thick Formed Steel Tab. Frame shall be powdercoated after welding.

**HARDWARE:** All nuts, bolts, screws, and lock washers used in the assembly shall be stainless steel, yellow dichromate plated steel, blue-coat plated steel, mechanically galvanized or powder coated/yellow dichromate plated steel. All primary fasteners shall be 304 alloy stainless steel. Fasteners with yellow dichromate treatment have an electro-deposited, 99.9% pure zinc substrate applied from a specially formulated solution sealed with a yellow dichromate top coat designed to work in conjunction with the zinc plating.

## UP168J SIT-UP/BACK EXTENSION (FOOTING) UP168S SIT-UP/BACK EXTENSION (IN GROUND) UP168M SIT-UP/BACK EXTENSION (SURFACE MOUNT)

### **INSTALLATION INSTRUCTIONS FOR UP168J (FOOTING):**

1. Attach Sit up & Back Extension Assembly to Main Post Assembly using Cap, 1/2" x 6 1/2" Hex Head Bolt, 1/2" Lockwasher, 1/2" Flatwasher and Base. See Sit-Up/Back Extension Assembly Detail.
2. Attach Coated Metal Insert to Frame using 3/8" x 3/4" Carriage Bolt, 3/8" Flatwasher, and 3/8" Lock Nut. See Metal Insert to Frame Detail.
3. Attach Cushion to Frame using M8 x 25 Button Head Cap Screw, 8MM Lockwasher, and 8MM Flat Washer, which are included with Cushion. See Cushion to Frame Detail.
4. Dig holes or drill holes according to Plan View and Elevation View. NOTE: Due to extremes in weather and soil conditions, hole size may have to be increased to meet local conditions.
5. Fill holes with concrete. While the concrete is still soft, yet firm enough to support the Sit-Up/Back Extension, place Anchor Bolts in position. See Footing Detail.. NOTE: Use Sit-Up/Back Extension as a template for Anchor Bolt location, then remove Sit-Up/Back Extension.

**IMPORTANT: DO NOT MOUNT THE SIT-UP/BACK EXTENSION TO THE ANCHOR BOLTS FOR AT LEAST 7 DAYS.**

6. After concrete has cured and set for a minimum of 7 days, attach Sit-Up/Back Extension to 3/4" Anchor Bolt using 3/4" Hex Nut, 3/4" Lockwasher, and 3/4" Flatwasher (2" O.D.). See Footing Assembly Detail.
5. Attach Supports to 1/2" Anchor Bolt using 1/2" Hex Nut, 1/2" Lockwasher, and 5/8" S.S. Flat Washer. See Footing Support Detail.
6. Attach Base Cover to Equipment Post using Base Cover Nut and Base Cover Bolt included with Base Cover. See Base Cover Detail.

### **INSTALLATION INSTRUCTIONS FOR UP168S (IN GROUND):**

1. Attach Sit up & Back Extension Assembly to Main Post Assembly using Cap, 1/2" x 6 1/2" Hex Head Bolt, 1/2" Lockwasher, 1/2" Flatwasher and Base. See Sit-Up/Back Extension Assembly Detail.
2. Attach Coated Metal Insert to Frame using 3/8" x 3/4" Carriage Bolt, 3/8" Flatwasher, and 3/8" Lock Nut. See Metal Insert to Frame Detail.
3. Attach Cushion to Frame using M8 x 25 Button Head Cap Screw, 8MM Lockwasher, and 8MM Flat Washer, which are included with Cushion. See Cushion to Frame Detail.
4. Dig holes or drill holes according to Plan View and Elevation View. **NOTE:** Due to extremes in weather and soil conditions, hole size may have to be increased to meet local conditions.
5. Attach the Footbuck Weld Assembly to the Sit-Up/Back Extension using 3/4" Hex Nut, 3/4" Lockwasher, 3/4" Flatwasher (2" O.D.), 3/4" x 2" Hex Head Cap Screw. See In-Ground Assembly Detail.
6. Attach the Support Weld Assembly to the Sit-Up/Back Extension using 1/2" Hex Nut, 1/2" Lockwasher, 5/8" S.S. Flat Washer, and 1/2" x 2 1/2" Hex Bolt. See In Ground Support Assembly Detail.
7. Place Sit-Up/Back Extension into hole making sure it rests on the brick. See In-Ground Detail.
8. Level Sit-Up/Back Extension using sway bracing.
9. Pour concrete according to the Plan View and Elevation View. Allow concrete to cure for a minimum of 7 days.
10. Attach Base Cover to Equipment Post using Base Cover Nut and Base Cover Bolt included with Base Cover. See Base Cover Detail.

Issued/Revised: 10/05/16

800.458.5872



www.actionfitoutdoors.com

3

## UP168J SIT-UP/BACK EXTENSION (FOOTING) UP168S SIT-UP/BACK EXTENSION (IN GROUND) UP168M SIT-UP/BACK EXTENSION (SURFACE MOUNT)

### **INSTALLATION INSTRUCTIONS FOR UP168M (SURFACE MOUNT):**

1. Attach Sit up & Back Extension Assembly to Main Post Assembly using Cap, 1/2" x 6 1/2" Hex Head Bolt, 1/2" Lockwasher, 1/2" Flatwasher and Base. See Sit-Up/Back Extension Assembly Detail.
2. Attach Coated Metal Insert to Frame using 3/8" x 3/4" Carriage Bolt, 3/8" Flatwasher, and 3/8" Lock Nut. See Metal Insert to Frame Detail.
3. Attach Cushion to Frame using M8 x 25 Button Head Cap Screw, 8MM Lockwasher, and 8MM Flat Washer, which are included with Cushion. See Cushion to Frame Detail.
4. Mark correct location of holes for Wedge Anchor using the Base Plates as a guide.
5. Drill 3/4" x 2 1/2" holes in concrete for Wedge Anchors. See Surface Detail.
6. Drill 1/2" x 2 1/2" holes in concrete for Support Wedge Anchors. See Support Surface Detail.
7. Insert Wedge Anchors and secure Sit-Up/Back Extension with 3/4" Flatwasher (2" O.D.), 3/4" Lockwasher, and 3/4" Hex Nut. See Surface Assembly Detail.
8. Insert Wedge Anchors and secure Supports with 1/2" Flatwasher, 1/2" Lockwasher, and 1/2" Hex Nut. See Surface Support Assembly Detail.
9. Attach Sit-up/Back Extension Assembly to Main Post Assembly using Nut Cap (M12), Nylon Nut (M12), Lockwasher (M12), Flatwasher (M12), Cap Washer (M12), and Hexagon Head Bolt (M 12x120). See Sit Up & Back Extension Assembly Detail.

### **MAINTENANCE PROCEDURE:**

Periodically check hardware for tightness, and tighten as necessary. Always check all parts for breakage or wear, and immediately put equipment out of service until any faulty parts found are repaired or replaced. Also Check all metal parts for rust, paint loss and touch-up if necessary with paint. Check for welded areas and verify integrity. Check periodically resilient surfacing for appropriate depth and remove extraneous materials that could cause injury, infection, or disease. Maintain detailed installation, inspection, maintenance, and repair records for each public-use playground equipment.

**UP168J SIT-UP/BACK EXTENSION (FOOTING)  
UP168S SIT-UP/BACK EXTENSION (IN GROUND)  
UP168M SIT-UP/BACK EXTENSION (SURFACE MOUNT)**

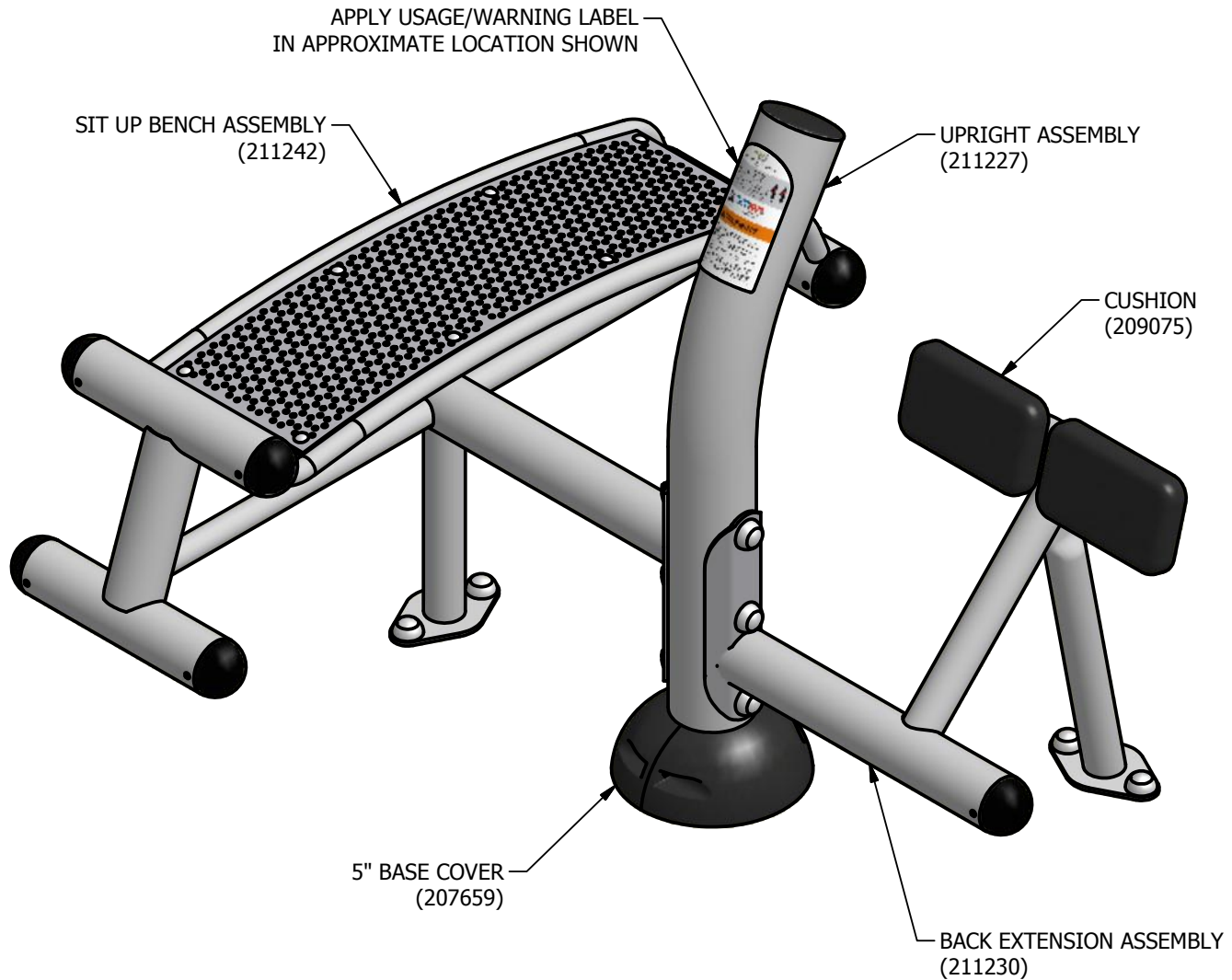

**FINISHED ASSEMBLY**

**UP168J SIT-UP/BACK EXTENSION (FOOTING)**  
**UP168S SIT-UP/BACK EXTENSION (IN GROUND)**  
**UP168M SIT-UP/BACK EXTENSION (SURFACE MOUNT)**

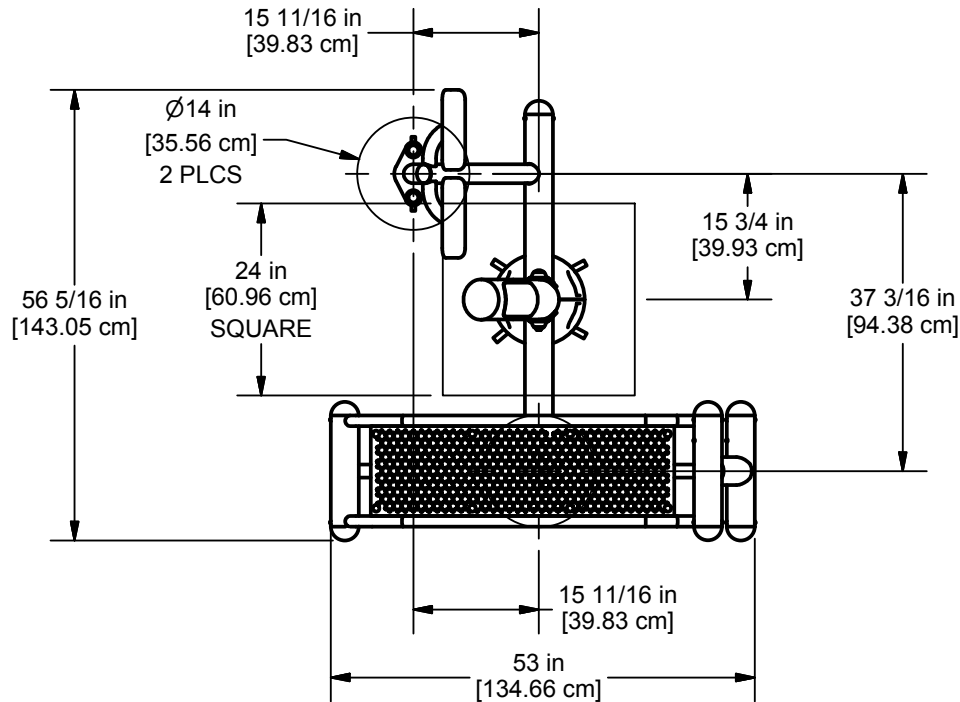

**PLAN VIEW**

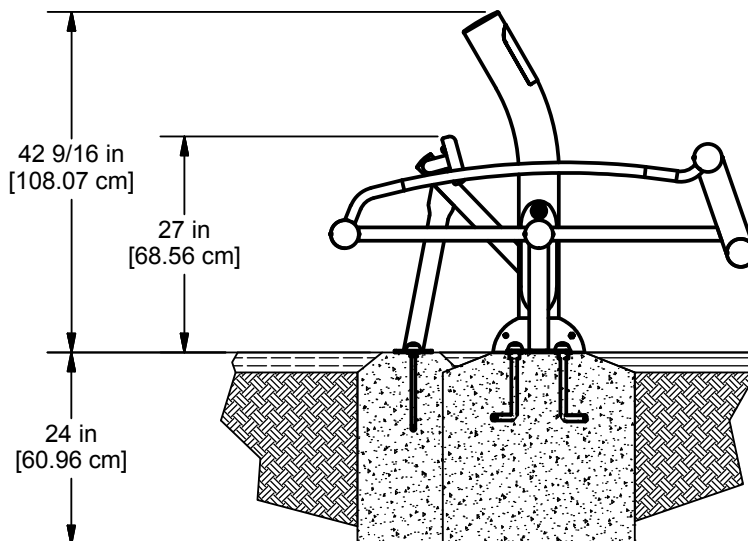

**ELEVATION VIEW**

**UP168J (FOOTING)**

Issued/Revised: 10/05/16



**UP168J SIT-UP/BACK EXTENSION (FOOTING)  
 UP168S SIT-UP/BACK EXTENSION (IN GROUND)  
 UP168M SIT-UP/BACK EXTENSION (SURFACE MOUNT)**

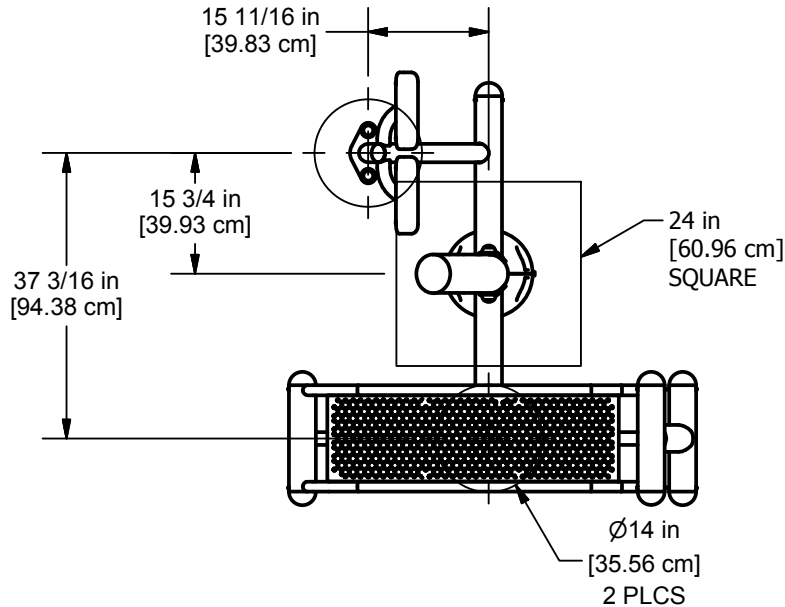

**PLAN VIEW**

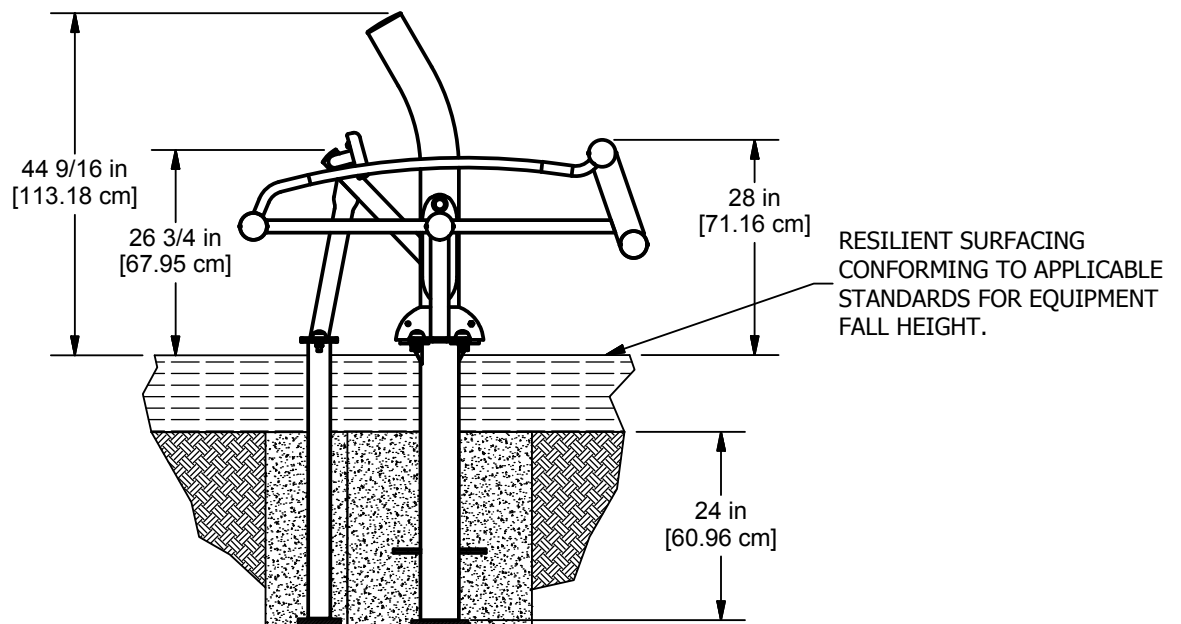

**ELEVATION VIEW  
 UP168S (IN GROUND)**

Issued/Revised: 10/05/16



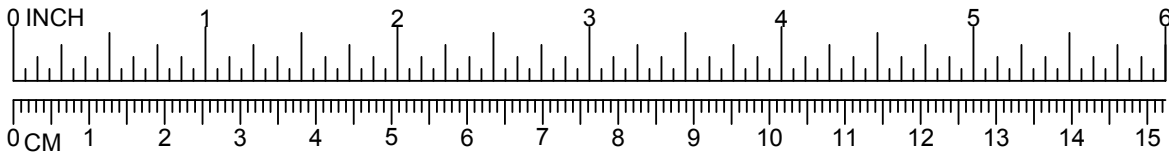

# UP168J SIT-UP/BACK EXTENSION (FOOTING) UP168S SIT-UP/BACK EXTENSION (IN GROUND) UP168M SIT-UP/BACK EXTENSION (SURFACE MOUNT)

**CONCRETE REQUIRED:**  
 .30 CUBIC YARDS  
 .23 CUBIC METERS

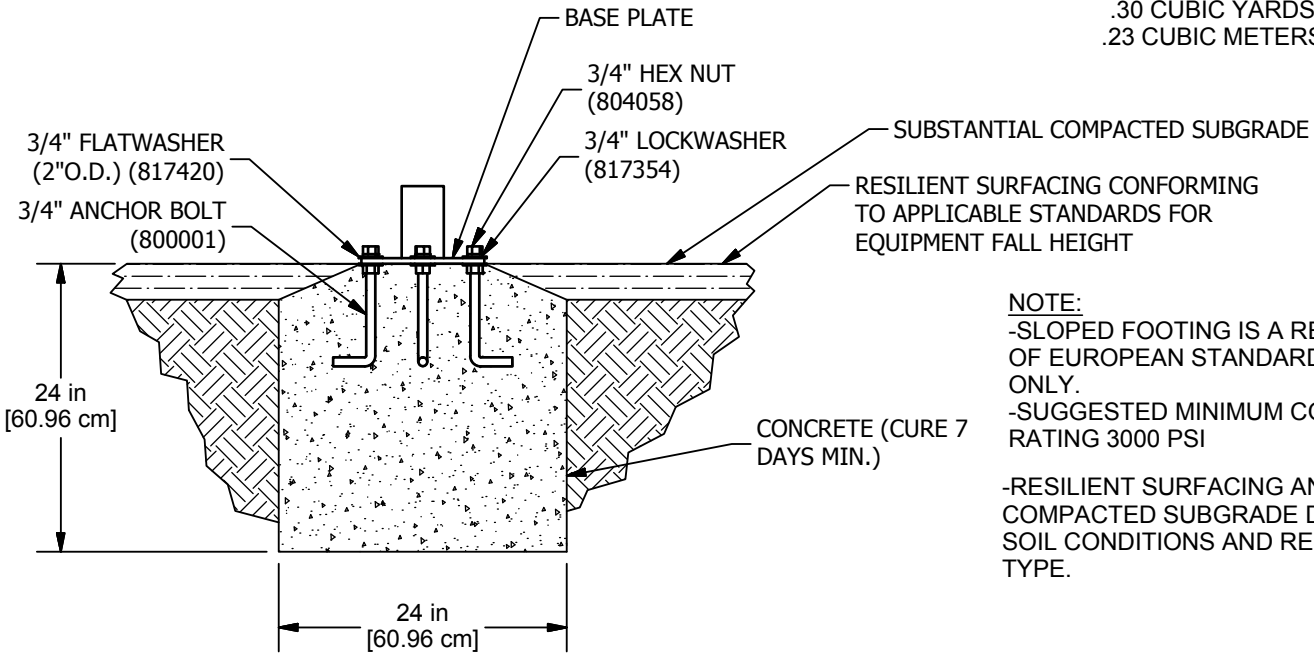

**NOTE:**  
 -SLOPED FOOTING IS A REQUIREMENT OF EUROPEAN STANDARD EN1176-1 ONLY.  
 -SUGGESTED MINIMUM CONCRETE RATING 3000 PSI  
 -RESILIENT SURFACING AND SUBSTANTIAL COMPACTED SUBGRADE DEPTHS DEPEND ON SOIL CONDITIONS AND RESILIENT SURFACING TYPE.

## FOOTING DETAIL

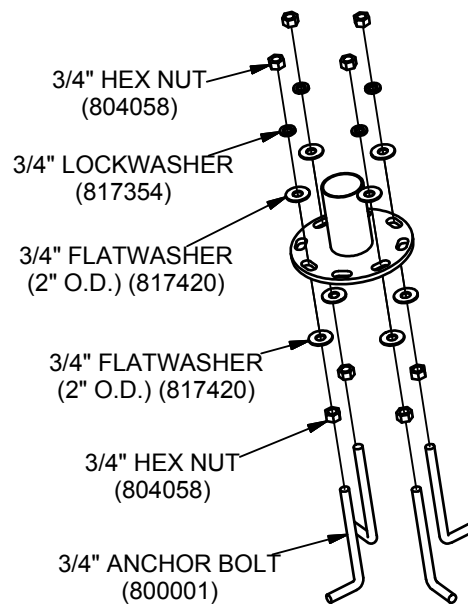

## FOOTING ASSEMBLY DETAIL

### UP168J (FOOTING)

Issued/Revised: 10/05/16





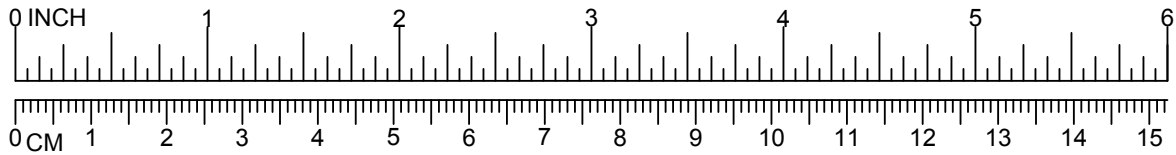

**UP168J SIT-UP/BACK EXTENSION (FOOTING)**  
**UP168S SIT-UP/BACK EXTENSION (IN GROUND)**  
**UP168M SIT-UP/BACK EXTENSION (SURFACE MOUNT)**

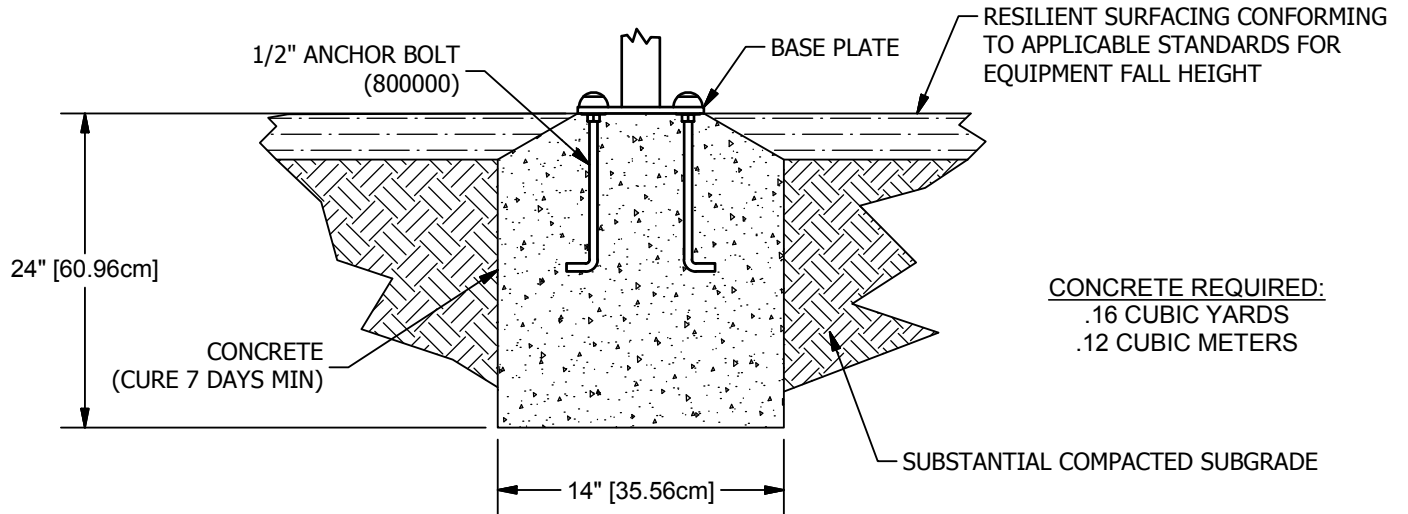

**CONCRETE REQUIRED:**  
 .16 CUBIC YARDS  
 .12 CUBIC METERS

**NOTE:**

- SLOPED FOOTING IS A REQUIREMENT OF EUROPEAN STANDARD EN1176-1 ONLY.
- SUGGESTED MINIMUM CONCRETE RATING 3000 PSI

**FOOTING SUPPORT DETAIL**  
**UP168J (FOOTING)**

- RESILIENT SURFACING AND SUBSTANTIAL COMPACTED SUBGRADE DEPTHS DEPEND ON SOIL CONDITIONS AND RESILIENT SURFACING TYPE.

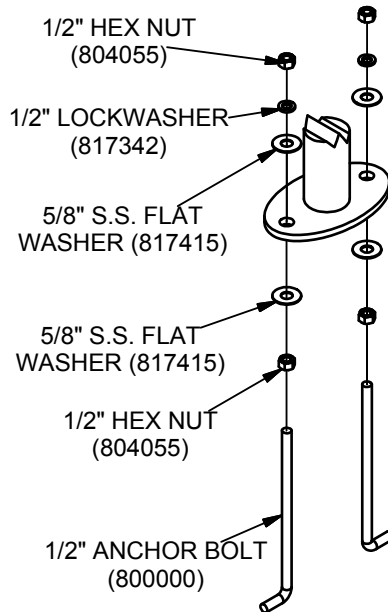

**FOOTING SUPPORT ASSEMBLY DETAIL**  
**UP168J (FOOTING)**

Issued/Revised: 10/05/16



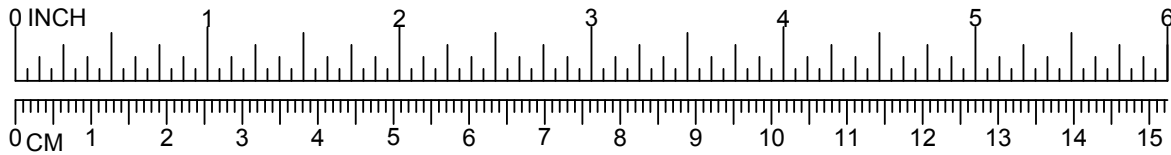

# UP168J SIT-UP/BACK EXTENSION (FOOTING) UP168S SIT-UP/BACK EXTENSION (IN GROUND) UP168M SIT-UP/BACK EXTENSION (SURFACE MOUNT)

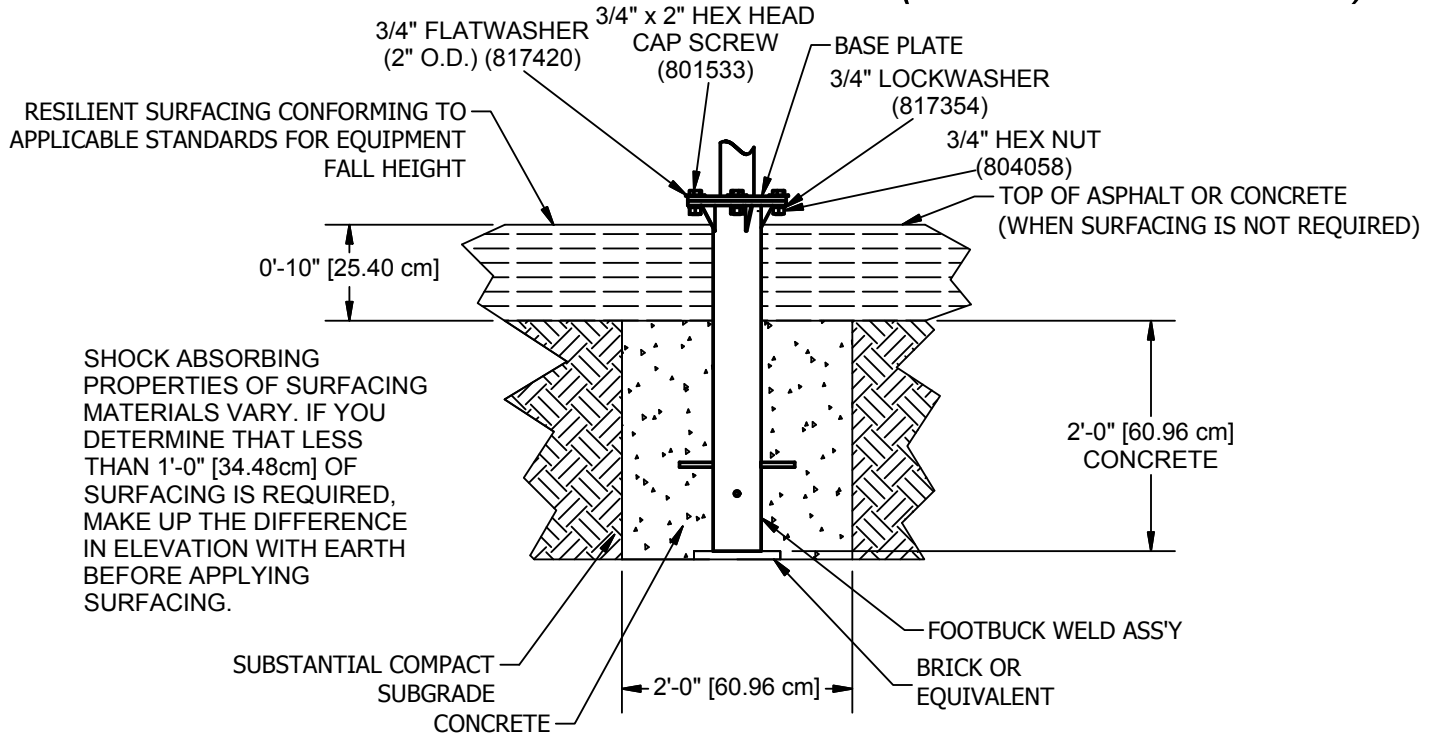

## IN GROUND DETAIL

**CONCRETE REQUIRED:**

.30 CUBIC YARDS  
 .23 CUBIC METERS

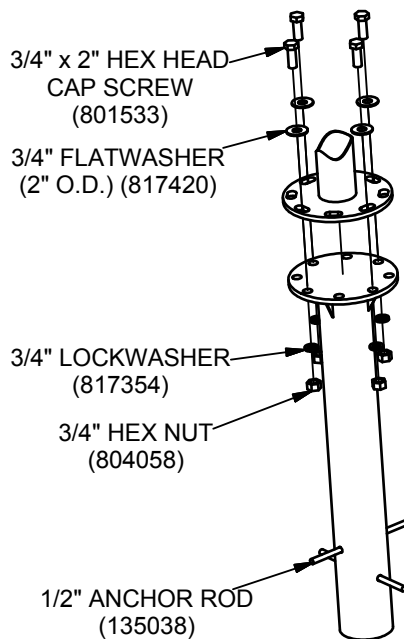

**NOTE:**

-RESILIENT SURFACING AND SUBSTANTIAL COMPACTED SUBGRADE DEPTHS DEPEND ON SOIL CONDITIONS AND RESILIENT SURFACING TYPE.

-SLOPED FOOTING (45° MIN) IS A REQUIREMENT OF EUROPEAN STANDARD EN1176-1 ONLY.

-SUGGESTED MINIMUM CONCRETE RATING 3000 PSI.

## IN GROUND ASSEMBLY DETAIL UP168S (IN GROUND)

Issued/Revised: 10/05/16



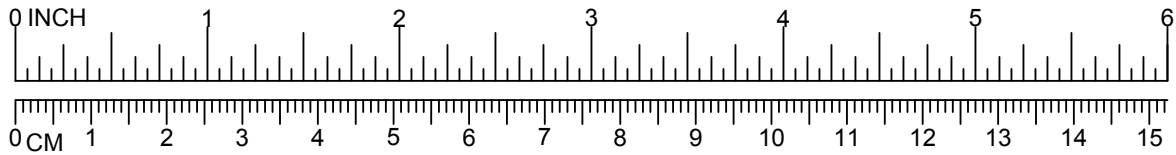

**UP168J SIT-UP/BACK EXTENSION (FOOTING)**  
**UP168S SIT-UP/BACK EXTENSION (IN GROUND)**  
**UP168M SIT-UP/BACK EXTENSION (SURFACE MOUNT)**

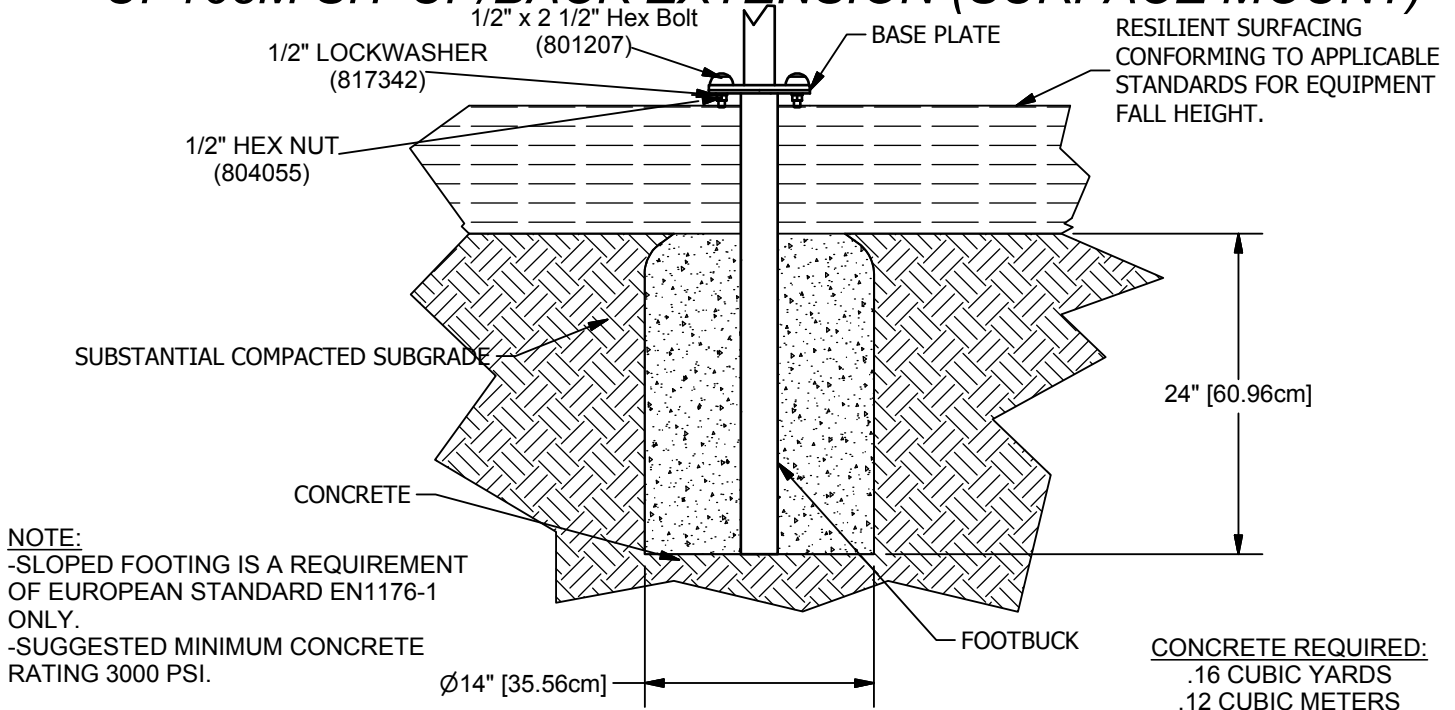

**IN GROUND SUPPORT DETAIL**

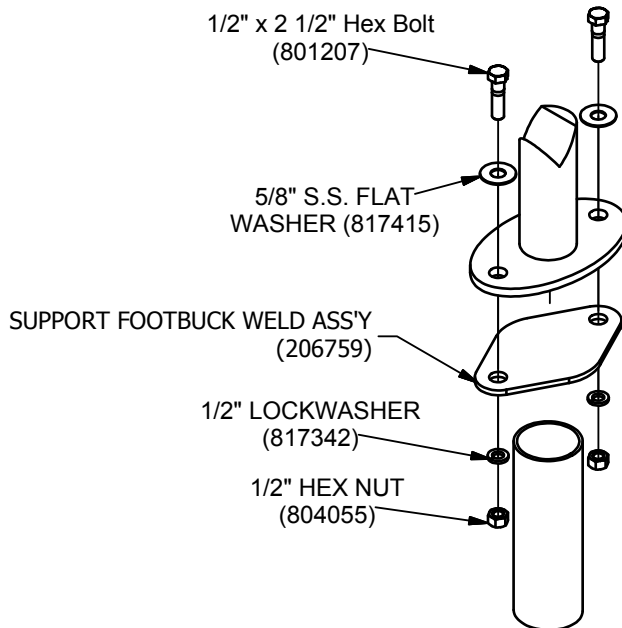

**IN GROUND SUPPORT ASSEMBLY DETAIL**  
**UP168S (IN GROUND)**

Issued/Revised: 10/05/16



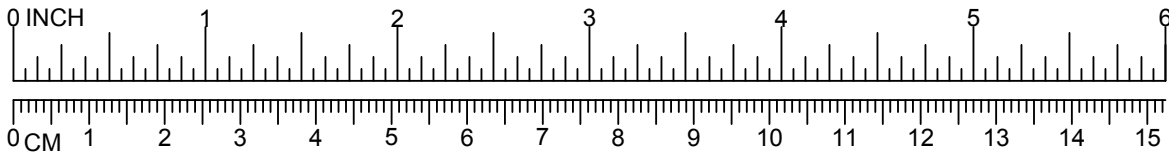

**UP168J SIT-UP/BACK EXTENSION (FOOTING)**  
**UP168S SIT-UP/BACK EXTENSION (IN GROUND)**  
**UP168M SIT-UP/BACK EXTENSION (SURFACE MOUNT)**

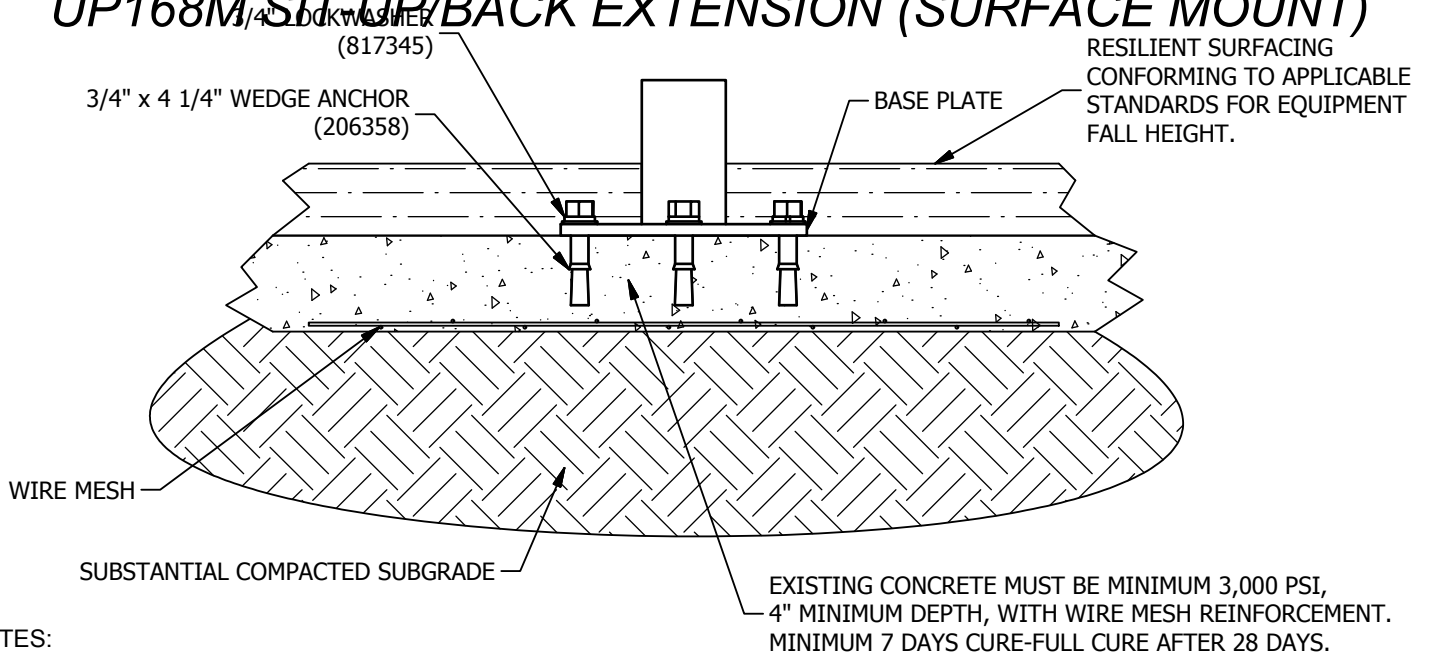

NOTES:  
 -LOOSE FILL SURFACING NOT RECOMMENDED FOR SURFACE MOUNT.

**SURFACE DETAIL**

-RESILIENT SURFACING AND SUBSTANTIAL COMPACTED SUBGRADE DEPTHS DEPEND ON SOIL CONDITIONS AND RESILIENT SURFACING TYPE.

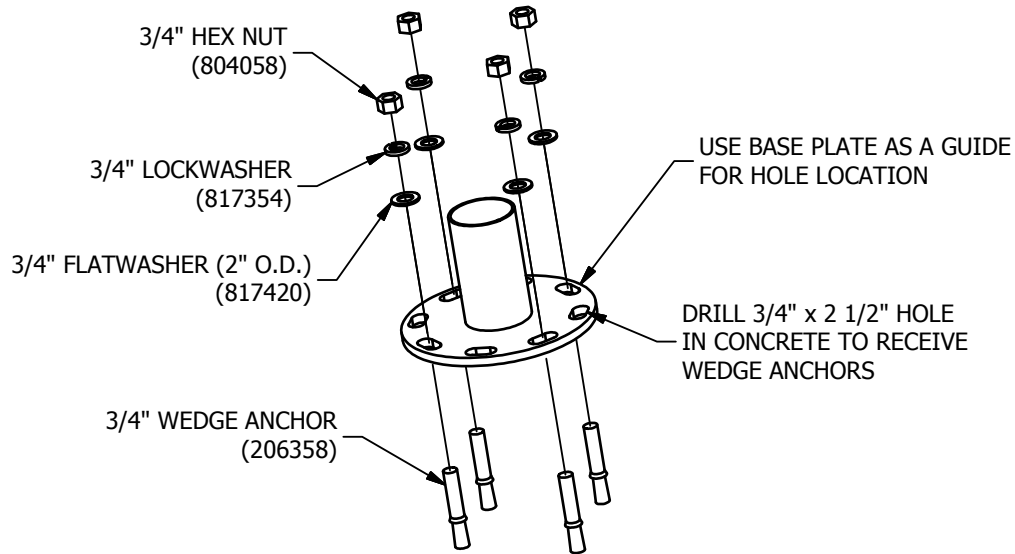

**SURFACE ASSEMBLY DETAIL**  
**UP168M (SURFACE MOUNT)**

Issued/Revised: 10/05/16



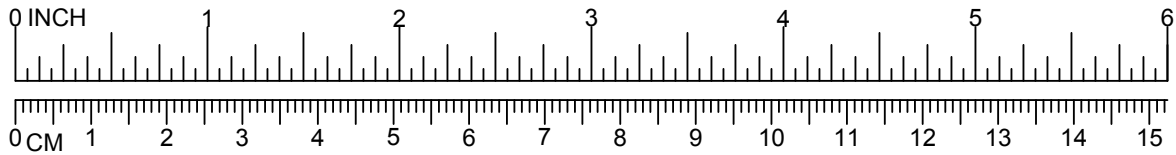

**UP168J SIT-UP/BACK EXTENSION (FOOTING)  
 UP168S SIT-UP/BACK EXTENSION (IN GROUND)  
 UP168M SIT-UP/BACK EXTENSION (SURFACE MOUNT)**

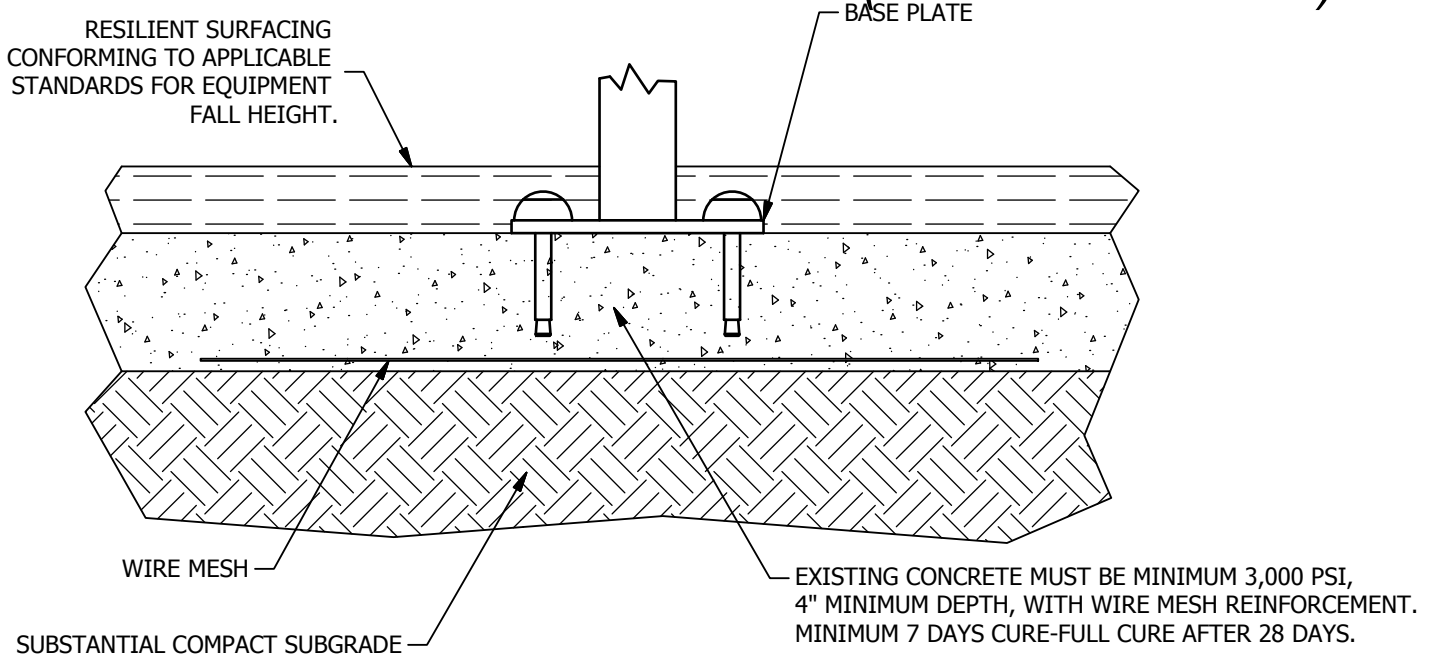

**SURFACE SUPPORT DETAIL**

**NOTES:**

-LOOSE FILL SURFACING NOT RECOMMENDED FOR SURFACE MOUNT.

-RESILIENT SURFACING AND SUBSTANTIAL COMPACTED SUBGRADE DEPTHS DEPEND ON SOIL CONDITIONS AND RESILIENT SURFACING TYPE.

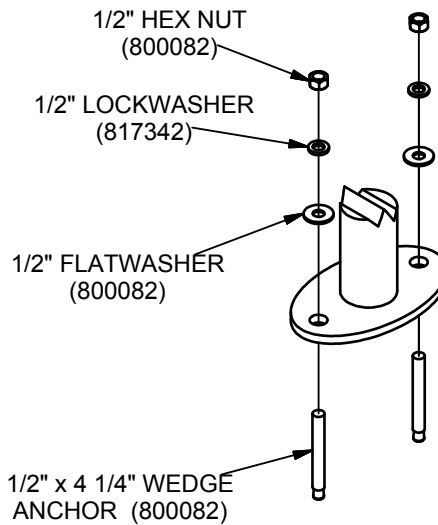

**SURFACE SUPPORT ASSEMBLY DETAIL  
 UP168M (SURFACE MOUNT)**

Issued/Revised: 10/05/16



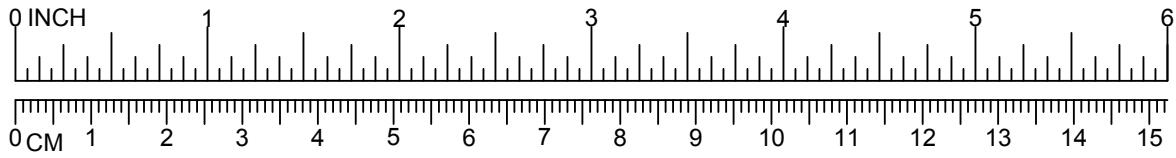

**UP168J SIT-UP/BACK EXTENSION (FOOTING)  
UP168S SIT-UP/BACK EXTENSION (IN GROUND)  
UP168M SIT-UP/BACK EXTENSION (SURFACE MOUNT)**

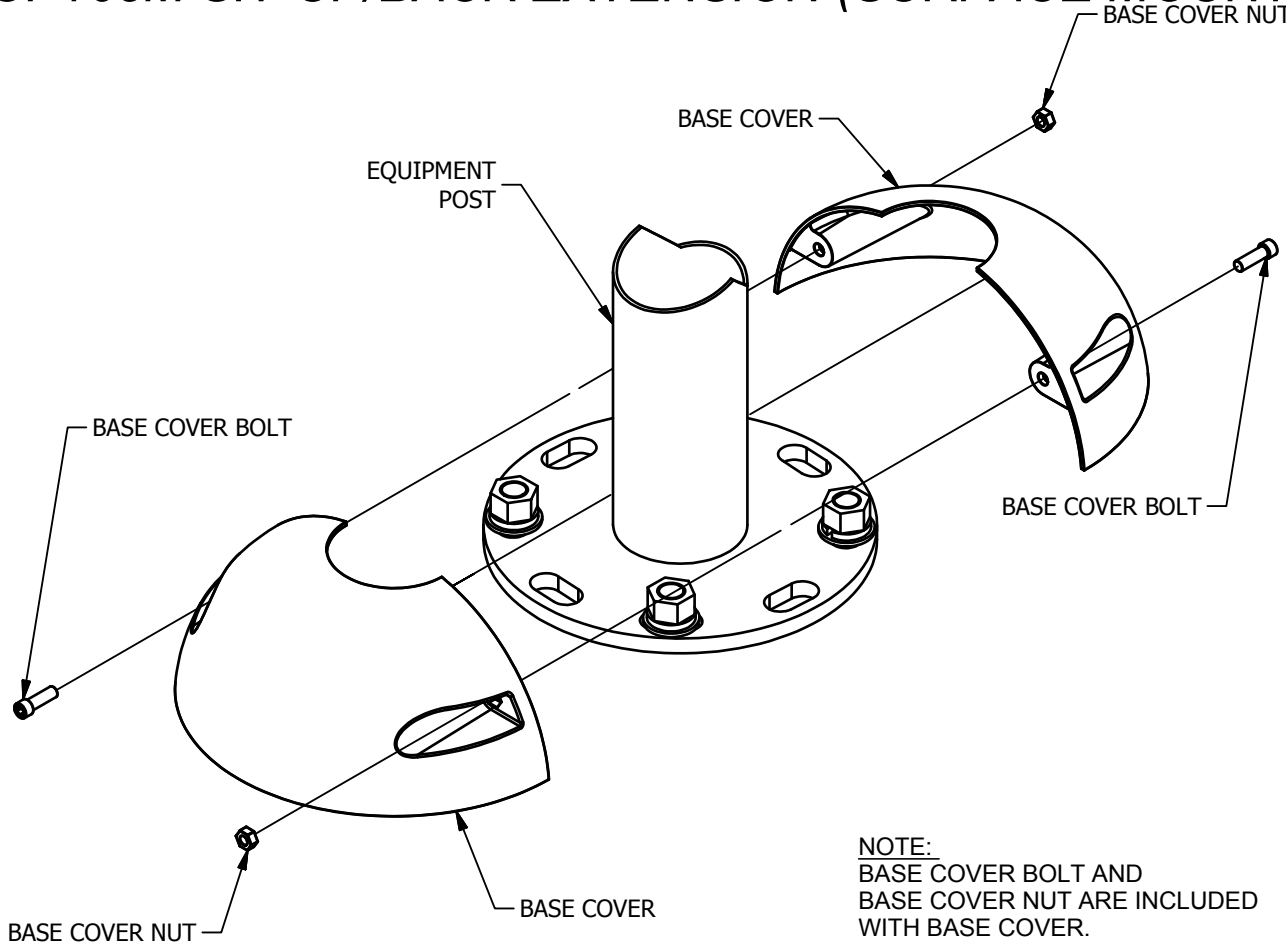

**BASE COVER DETAIL**

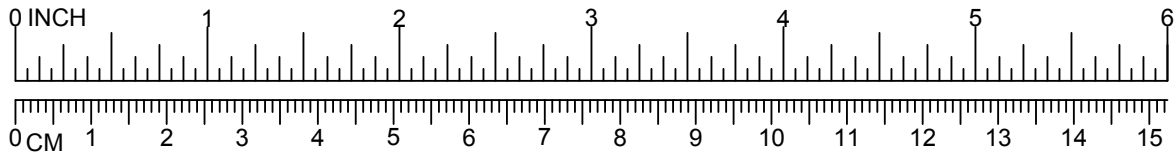

**UP168J SIT-UP/BACK EXTENSION (FOOTING)  
UP168S SIT-UP/BACK EXTENSION (IN GROUND)  
UP168M SIT-UP/BACK EXTENSION (SURFACE MOUNT)**

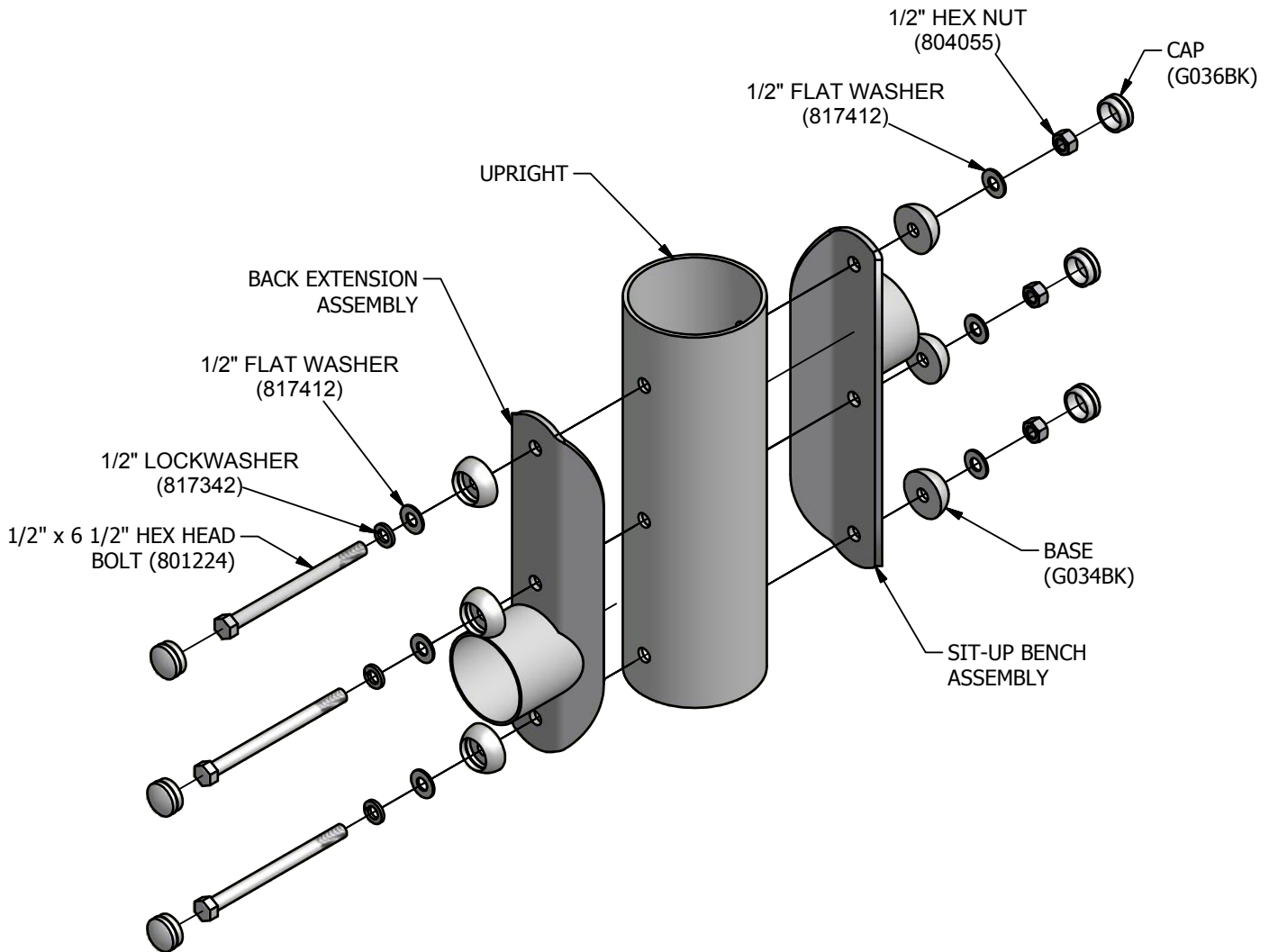

**BODY SIT UP & BACK EXTENSION  
ASSEMBLY DETAIL**





**UP168J SIT-UP/BACK EXTENSION (FOOTING)**  
**UP168S SIT-UP/BACK EXTENSION (IN GROUND)**  
**UP168M SIT-UP/BACK EXTENSION (SURFACE)**

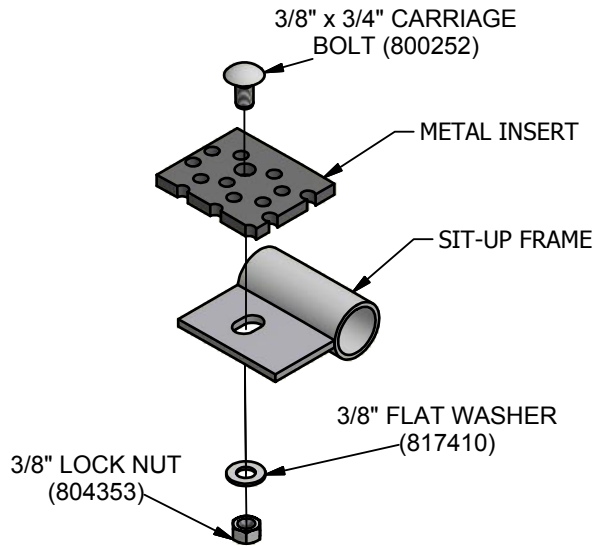

**METAL INSERT TO FRAME DETAIL**

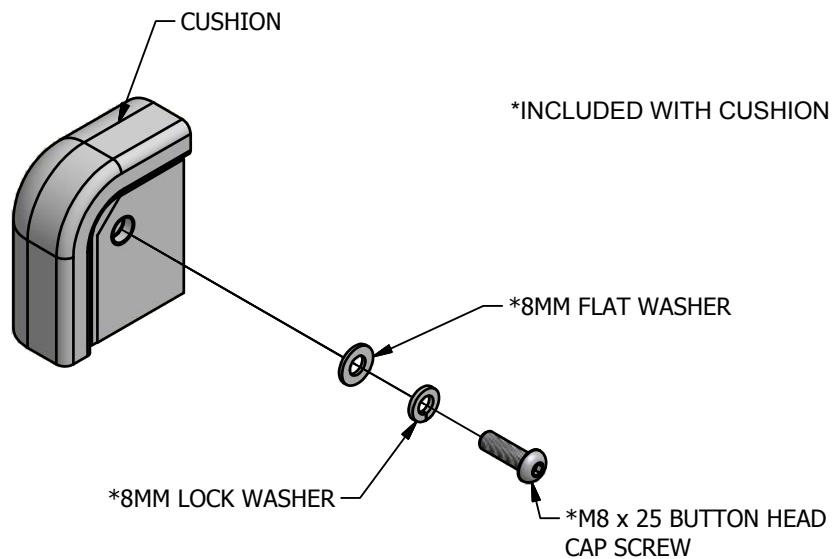

**CUSHION TO FRAME DETAIL**

Issued/Revised: 10/05/16

800.458.5872



www.ultraplay.com



**UP168J SIT-UP/BACK EXTENSION (FOOTING)**  
**UP168S SIT-UP/BACK EXTENSION (IN GROUND)**  
**UP168M SIT-UP/BACK EXTENSION (SURFACE)**

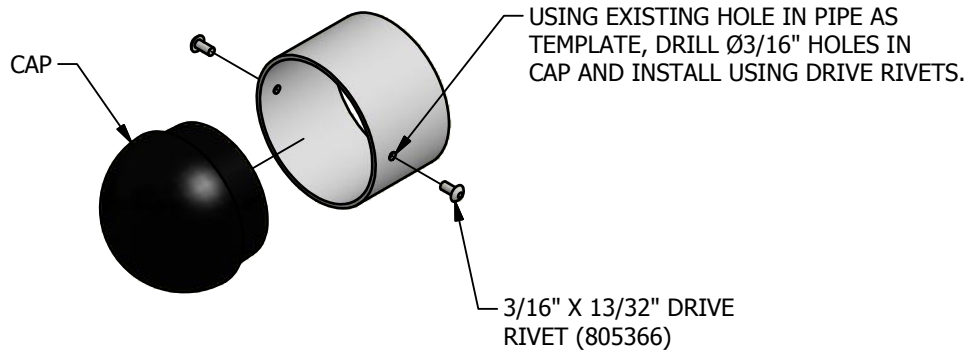

**DOME CAP DETAIL**

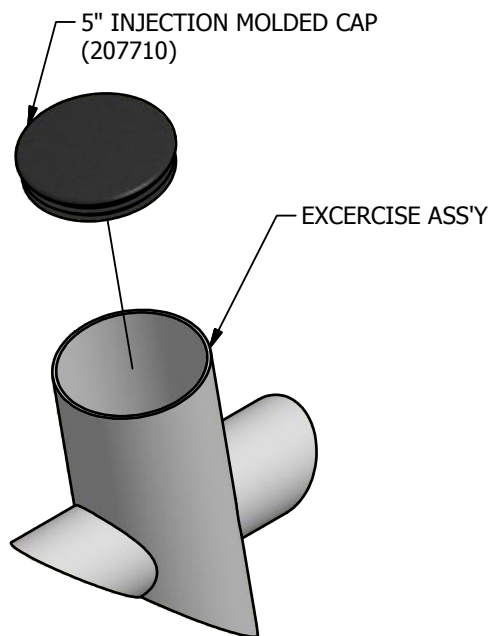

**CAP DETAIL**