

UP165J LAT PULL DOWN (FOOTING) UP165S LAT PULL DOWN (IN GROUND) UP165SM LAT PULL DOWN (SURFACE)

Parts List				
DESCRIPTION	UP165J (FOOTING)	UP165S (IN GROUND)	UP165SM (SURFACE)	PART NUMBER
LAT-PULL DOWN ASS'Y	1	1	1	211130
HANDLE ASS'Y	1	1	1	207486
5" BASE COVER	1	1	1	207659
SEAT/BACKREST	2	2	2	207600
FOOTBUCK WELD ASS'Y	0	1	0	206467
HARDWARE COMPLETE	0	0	1	403937
HARDWARE COMPLETE	1	0	0	403935
HARDWARE COMPLETE	0	1	0	403936
3/8" x 3/4" P.B.H.C.S. w/PATCH	8	8	8	812052*
3/8" LOCKWASHER	8	8	8	817334*
3/8" FLAT WASHER	8	8	8	817410*
3/4" x 2" HEX HEAD CAP SCREW	0	4	0	801533*
3/4" LOCKWASHER	4	4	4	817354*
3/4" FLATWASHER (2" O.D.)	8	4	0	817420*
3/4" HEX NUT	8	4	0	804058*
3/4" ANCHOR BOLT	4	0	0	800001*
3/4" X 4 1/4" WEDGE ANCHOR	0	0	4	206358*
1/2" ANCHOR ROD	0	2	0	135038*
5" INJECTION MOLDED CAP	1	1	1	207710*
1/2" FLAT WASHER	2	2	2	817412*
12MM DO-NUT BASE	2	2	2	G034BK*
12MM DO-NUT CAP	2	2	2	G036BK*
MACHINED SHAFT	1	1	1	206986*
1/2" FLATWASHER	2	2	2	817700*
1/2" x 1 1/4" B.H.C.S.	2	2	2	811062*
USAGE/WARNING LABEL	1	1	1	403895*

Unless Otherwise Specified, All Units of Measure are Each

**Items listed below Hardware Complete line are included with Hardware Complete Number*

Warning: During Installation, Hardware And Small Parts Are Choking Hazards For Young Children. Store Unused Parts Appropriately Until Assembly Is Completed. Once Assembly Is Completed, Remove Any Unused Parts From The Play Environment And Dispose/Save Them In A Secure Location. Any bolt end protruding more than two full threads beyond the face of the nut causes risk of clothing entanglement.

Promptly cut-off flush, file smooth, and treat to prevent corrosion.

Note: Peen Tee-Nuts and Flatwashers to match radius of pipe after assembly is complete.

Note: Loctite (supplied by others) should be used on any non-patch hardware.

UP165J LAT PULL DOWN (FOOTING) UP165S LAT PULL DOWN (IN GROUND) UP165SM LAT PULL DOWN (SURFACE)

SPECIFICATIONS

BACKREST/SEAT: The Backrest and seat shall be constructed from injection molded Nylon W6.

BASE COVER: The Base Cover shall be constructed from aluminum and powder coated.

BOLT GUARD CAP AND BASE: The Bolt Guard shall be constructed from Nylon PA6 and shall be black in color.

5" PLASTIC CAP: The 5" Plastic Cap shall be constructed from injection molded Low Density Polyethylene.

WELD ASSEMBLIES:

HANDLEBAR: The handlebar assemblies shall be constructed from 1.66" O.D. x 0.109" steel tubing. The assemblies shall be coated with a custom formula of TGIC polyester powder, after fabrication in conformance with the specifications outlined herein.

MAIN POST: Main Post assembly shall be manufactured with 2 15/16" x 9" and 1/8" thick hot rolled laser cut steel plate, 1/2" thick 10 1/4" dia. hot rolled laser cut steel plate, 2.375" O.D. x 0.154" SCH 40 pipe, 3.5" O.D. x 0.216" SCH 40 pipe, 4.5" O.D. x 0.25" SCH 40 pipe and 5" O.D. galvanized upright. The upright shall be 11 gauge (.120") galvanized round tubing, manufactured to ASTM A-500 Grade B tolerances from cold-formed steel conforming to ASTM A-569 Sheet Spec for steel coil. Minimum yield strength shall be 50,000 psi and minimum tensile strength shall be 55,000 psi. The exterior surface is hot dip galvanized, chromate conversion coated, and a clear high performance organic polymer is applied. The inside diameter has 81% minimum zinc rich primer capable of providing excellent rust protection and fabrication characteristics. All coatings are applied inside and out after welding for superior corrosion protection throughout. Exterior surface galvanizing zinc purity is 99% as per ASTM B-6 high grade and special high grade. Galvanizing coverage shall demonstrate the ability to exceed 1000 hours salt spray corrosion exposure in accordance with ASTM B-117. Internal surface zinc rich 81% minimum zinc dust content in organic resin, as per ASTM F-1234, Section 5.2.4, Type D. The main support frame assemblies and formed supports shall be coated with a custom formula of TGIC polyester powder, after fabrication in conformance with the specifications outlined herein.

MECHANISM PARTS:

BEARING HOLDER: Shall be manufactured with 4.245" O.D. stain steel machined tubing.

DISK BEARING: The disk bearing should be pre lubricated 3 3/8" O.D. 1 1/8" square bore stainless steel bearing.

MACHINED SHAFT: The machine shaft shall be manufactured with 1 3/16" X 9 1/8" stainless steel shaft.

RUBBER SPRING: Shall consist of rubber encapsulated by cast steel with a steel inner core.

FOOTBUCK: The upright shall be fabricated of 5" O.D. galvanized pipe and the mounting plate shall be a fabricated 3/8" hot rolled flat steel. Shall be a once piece welded unit.

POWDER COAT FINISH: Shall be an electrostatically applied custom formula of TGIC polyester powder. All components will be free of sharp edges and excess weld spatter and shall be cleaned in a six stage bath system with an iron phosphate wash, as a rust inhibitor, and a sealer to prevent flash rusting before coating. The coating shall have a super tough finish with maximum exterior durability and will have superior adhesion characteristics. Typical Characteristics are: 3.0 - 5.0 mil thickness and oven cured between 375 to 425 degrees Fahrenheit. Pencil Hardness H (ASTM D-3363), Impact (ASTM D-2794-69), Wedge Bend (ASTM D-522-68).

HARDWARE: All nuts, bolts, screws, and lock washers used in the assembly shall be stainless steel, yellow dichromate plated steel, blue-coat plated steel, mechanically galvanized or powder coated/yellow dichromate plated steel. All primary fasteners shall be 304 alloy stainless steel. Fasteners with yellow dichromate treatment have an electro-deposited, 99.9% pure zinc substrate applied from a specially formulated solution sealed with a yellow dichromate top coat designed to work in conjunction with the zinc plating.

UP165J LAT PULL DOWN (FOOTING) UP165S LAT PULL DOWN (IN GROUND) UP165SM LAT PULL DOWN (SURFACE)

NOTE: Do not overtighten bolts. To overtighten may cause buckling or dimpling of some parts.

NOTE: Read installation instructions thoroughly before starting assembly. Pour concrete only after final assembly is completed. Bracing material is required during assembly.

NOTE: Assembly and leveling times will be greatly reduced if a transit is used to set location and depth of ground holes.

INSTALLATION INSTRUCTIONS FOR UP165FJ(FOOTING):

1. Attach Handle Ass'y to Main Post Ass'y using Machined Shaft, 1/2" Flat Washer, 1/2" x 1 1/4" B.H.C.S., Base and Cap. See Handle Ass'y Detail.
2. Attach Seat to Frame using 3/8" x 3/4" P.B.H.C.S. w/Patch, 3/8" Lockwasher, and 3/8" Flat Washer. See Seat Detail.
3. Insert Cap into Post on Chest Press Assembly. See Cap Detail
4. Dig holes or drill holes according to Plan View and Elevation View. **NOTE:** Due to extremes in weather and soil conditions, hole size may have to be increased to meet local conditions.
5. Fill hole with concrete. While the concrete is still soft, yet firm enough to support the Lat Pull Down, Place (4) Anchor Bolts of the Lat Pull Down in position. See Footing Detail. **NOTE:** Use Lat Pull Down as a template for Anchor Bolt location, then remove Lat Pull Down.

IMPORTANT: DO NOT MOUNT THE LAT PULL DOWN TO THE ANCHOR BOLTS FOR AT LEAST 7 DAYS.

6. After concrete has cured and set for a minimum of 7 Days, attach Lat Pull Down to 3/4" Anchor Bolt using 3/4" Flat Washer (2" O.D.), 3/4" Lock Washer, and 3/4" Hex Nut. See Footing Assembly Detail.
7. Attach Base Cover to Equipment Post using Base Cover Nut and Base Cover Bolt included with Base Cover. See Base Cover Detail.

INSTALLATION INSTRUCTIONS FOR UP165S (IN GROUND):

1. Attach Handle Ass'y to Main Post Ass'y using Machined Shaft, 1/2" Flat Washer, 1/2" x 1 1/4" B.H.C.S., Base and Cap. See Handle Ass'y Detail.
2. Attach Seat to Frame using 3/8" x 3/4" P.B.H.C.S. w/Patch, 3/8" Lockwasher, and 3/8" Flat Washer. See Seat Detail.
3. Insert Cap into Post on Chest Press Assembly. See Cap Detail
3. Dig holes or drill holes according to Plan View and Elevation View. **NOTE:** Due to extremes in weather and soil conditions, hole size may have to be increased to meet local conditions.
4. Attach the Footbuck Weld Assembly to the Lat Pull Down using 3/4" Hex Nut, 3/4" Lockwasher, 3/4" Flatwasher (2" O.D.), 3/4" x 2" Hex Head Cap Screw. See In-Ground Assembly Detail.
5. Place Lat Pull Down into hole making sure it rests on the brick. See In-Ground Detail.
6. Level Lat Pull Down using sway bracing.
7. Pour concrete according to the Plan View and Elevation View. Allow concrete to cure for a minimum of 7 days.
8. Attach Base Cover to Equipment Post using Base Cover Detail.

UP165J LAT PULL DOWN (FOOTING) UP165S LAT PULL DOWN (IN GROUND) UP165SM LAT PULL DOWN (SURFACE)

INSTALLATION INSTRUCTIONS FOR UP165SM (SURFACE):

1. Attach Handle Ass'y to Main Post Ass'y using Machined Shaft, 1/2" Flat Washer, 1/2" x 1 1/4" B.H.C.S., Base and Cap. See Handle Ass'y Detail.
2. Attach Seat to Frame using 3/8" x 3/4" P.B.H.C.S. w/Patch, 3/8" Lockwasher, and 3/8" Flat Washer. See Seat Detail.
3. Insert Cap into Post on Chest Press Assembly. See Cap Detail
4. Mark correct location of holes for Wedge Anchor using the Base Plate as a guide.
5. Drill 3/4" x 2 1/2" hole in concrete for Wedge Anchor. See Surface Detail.
6. Insert Wedge Anchors and secure with 3/4" Flatwasher (2" O.D.), 3/4" Lockwasher, and 3/4" Hex Nut. See Surface Assembly Detail.
7. Attach Base Cover to Equipment Post using Base Cover Detail.

UP165J LAT PULL DOWN (FOOTING) UP165S LAT PULL DOWN (IN GROUND) UP165SM LAT PULL DOWN (SURFACE)

MAINTENANCE PROCEDURE:

Periodically check hardware for tightness, and tighten as necessary. Always check all parts for breakage or wear, and immediately put equipment out of service until any faulty parts found are repaired or replaced. Also Check all metal parts for rust, paint loss and touch-up if necessary with paint. Check for welded areas and verify integrity. Check periodically resilient surfacing for appropriate depth and remove extraneous materials that could cause injury, infection, or disease. Maintain detailed installation, inspection, maintenance, and repair records for each public-use playground equipment.

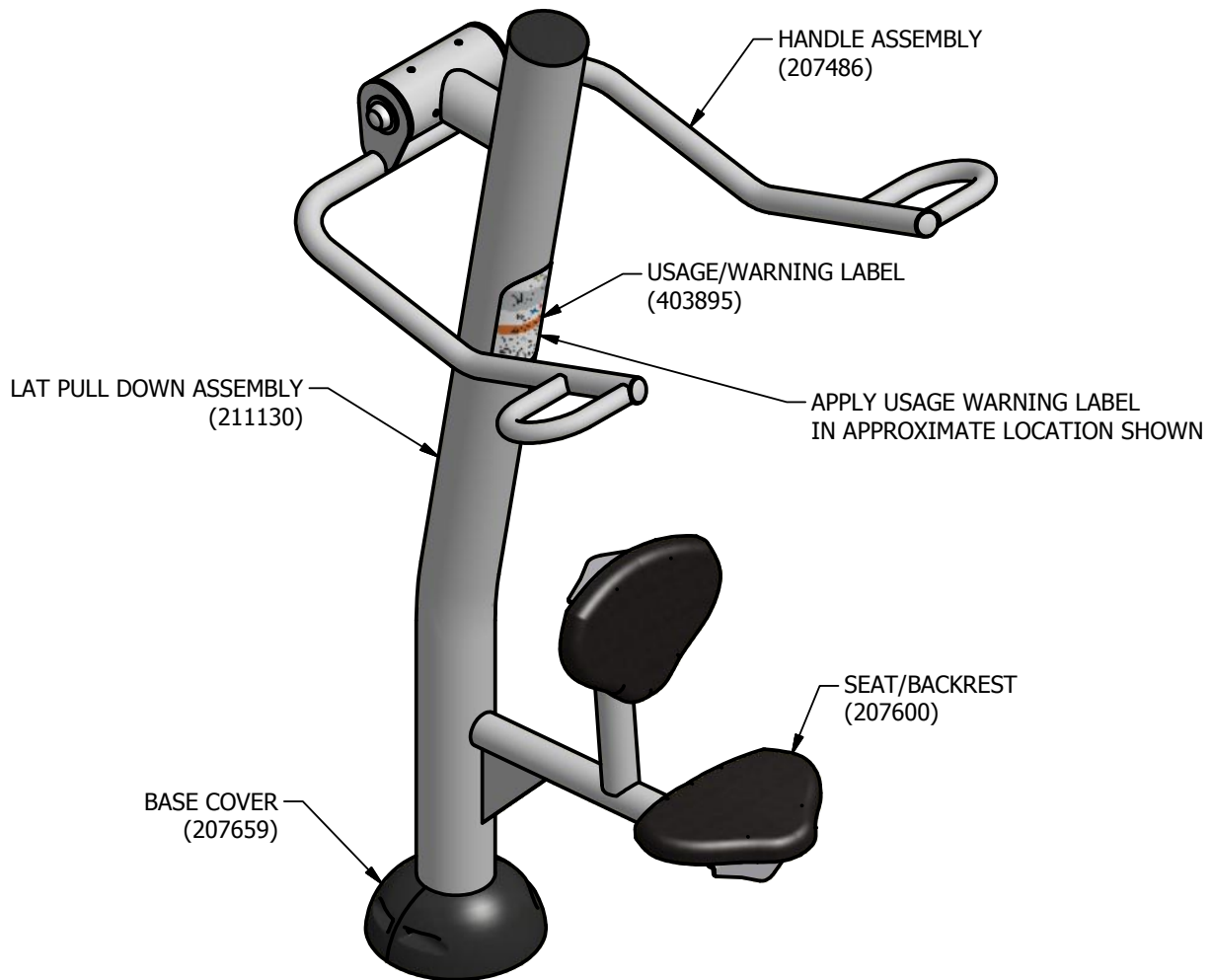

FINISHED ASSEMBLY

**UP165J LAT PULL DOWN (FOOTING)
UP165S LAT PULL DOWN (IN GROUND)
UP165SM LAT PULL DOWN (SURFACE)**

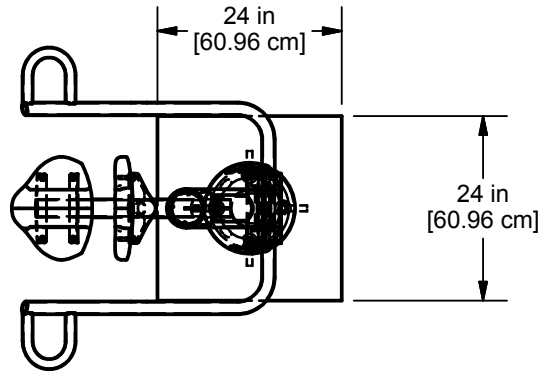

PLAN VIEW

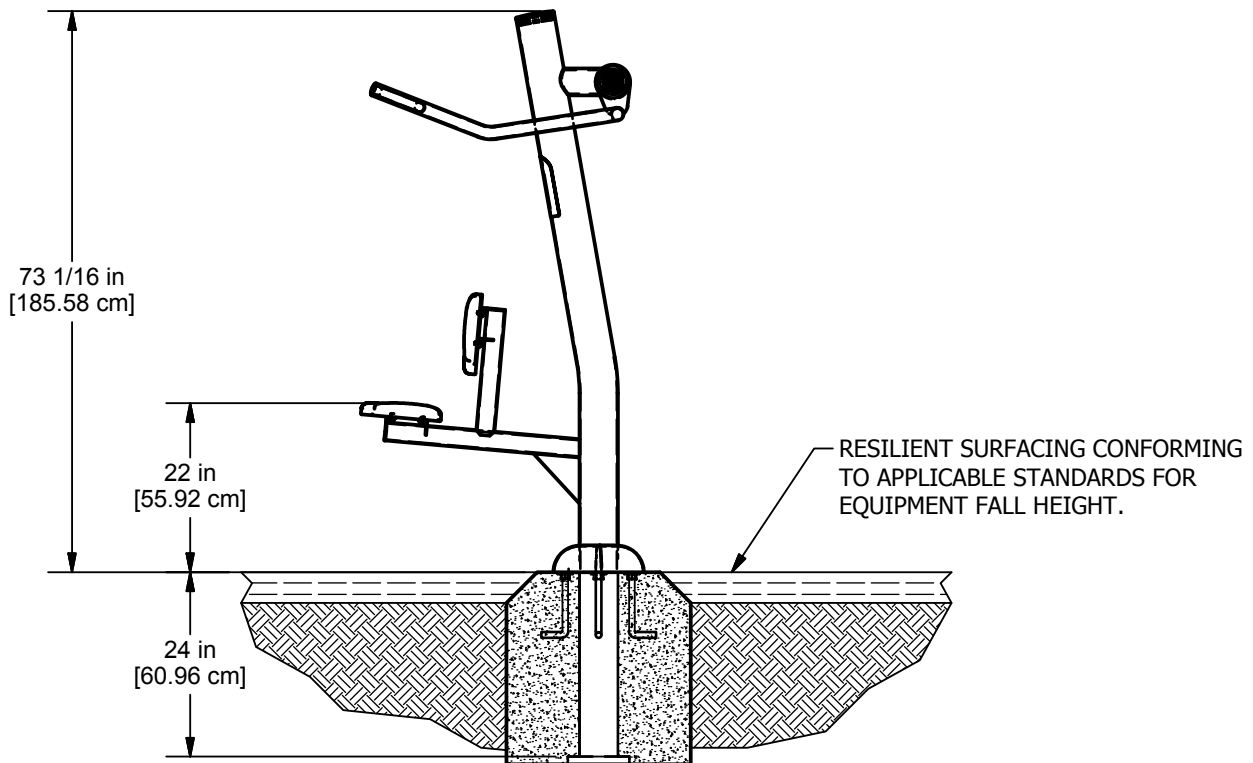

ELEVATION VIEW
UP165J (FOOTING)

Issued/Revised: 01/24/17



**UP165J LAT PULL DOWN (FOOTING)
UP165S LAT PULL DOWN (IN GROUND)
UP165SM LAT PULL DOWN (SURFACE)**

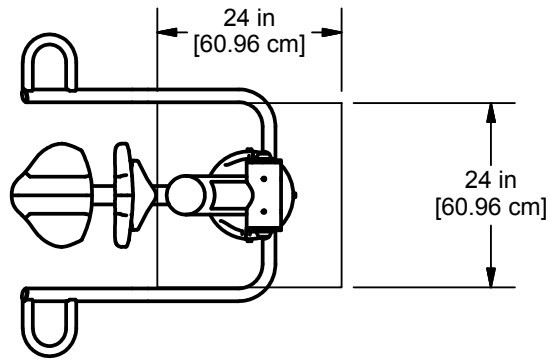

PLAN VIEW

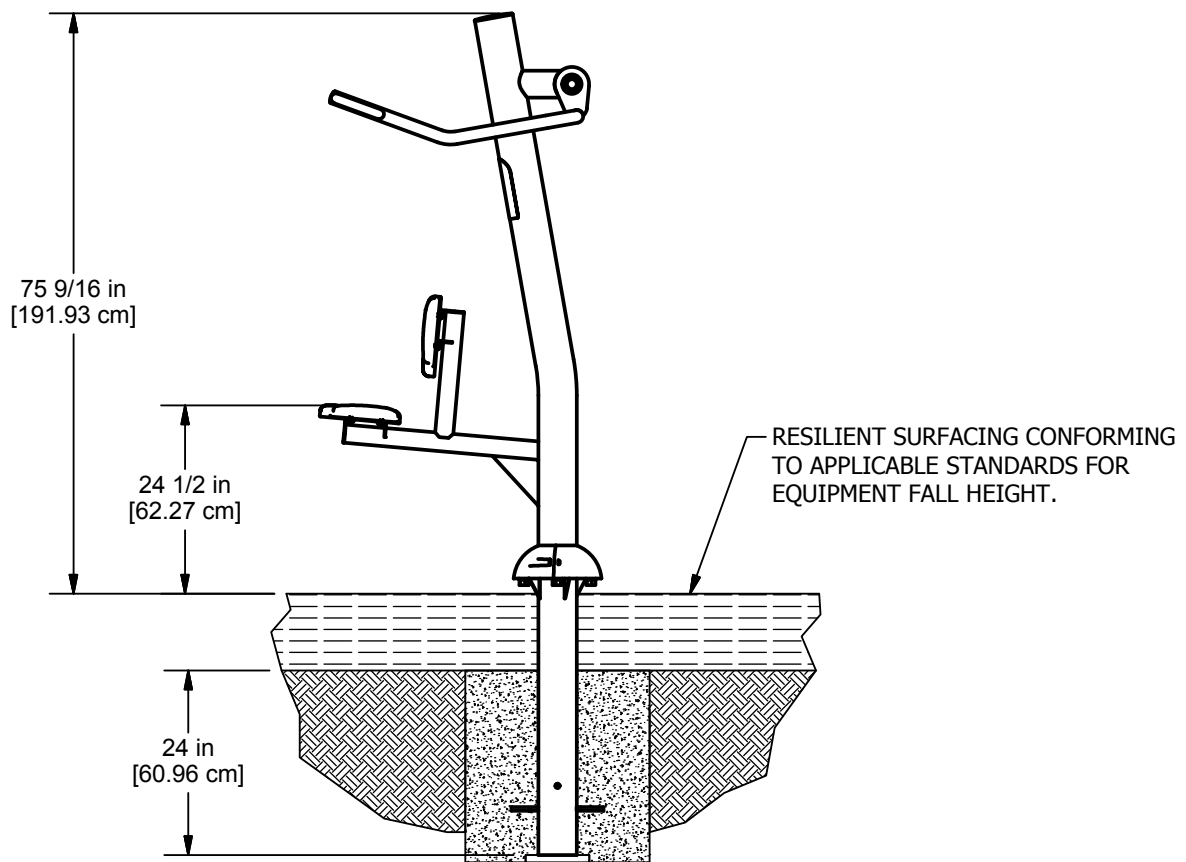

**ELEVATION VIEW
UP165S (IN GROUND)**

Issued/Revised: 01/24/17



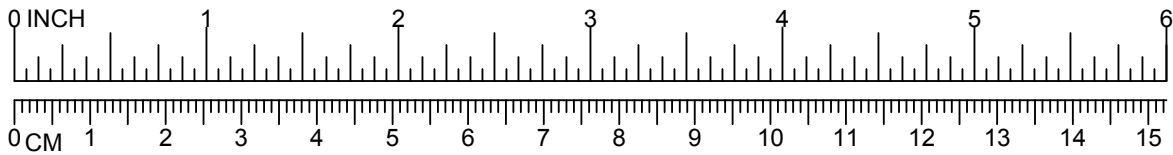

**UP165J LAT PULL DOWN (FOOTING)
 UP165S LAT PULL DOWN (IN GROUND)
 UP165SM LAT PULL DOWN (SURFACE)**

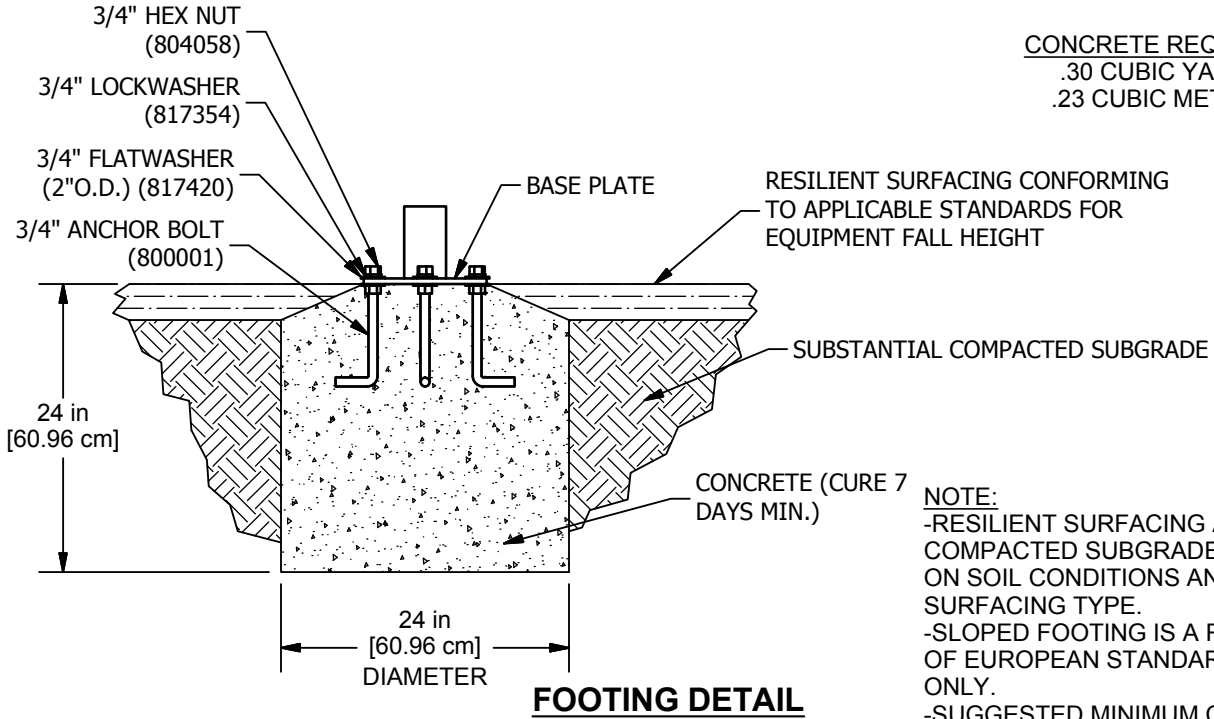

CONCRETE REQUIRED:
 .30 CUBIC YARDS
 .23 CUBIC METERS

NOTE:
 -RESILIENT SURFACING AND SUBSTANTIAL COMPACTED SUBGRADE DEPTHS DEPEND ON SOIL CONDITIONS AND RESILIENT SURFACING TYPE.
 -SLOPED FOOTING IS A REQUIREMENT OF EUROPEAN STANDARD EN1176-1 ONLY.
 -SUGGESTED MINIMUM CONCRETE RATING 3000 PSI.

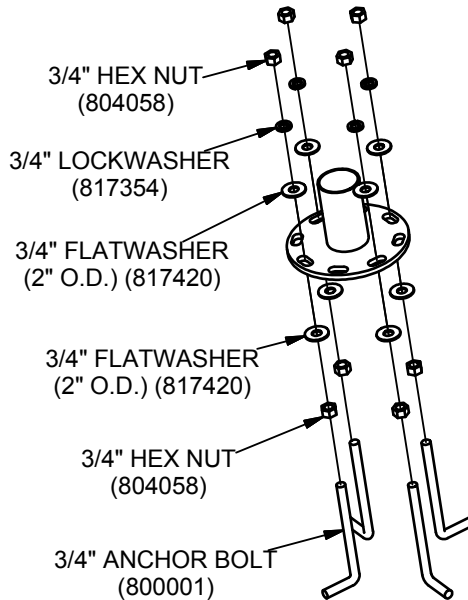

**FOOTING ASSEMBLY DETAIL
 UP165J (FOOTING)**

Issued/Revised: 01/24/17



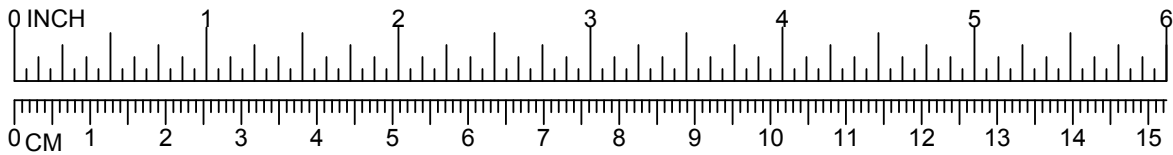

UP165J LAT PULL DOWN (FOOTING) UP165S LAT PULL DOWN (IN GROUND) UP165SM LAT PULL DOWN (SURFACE)

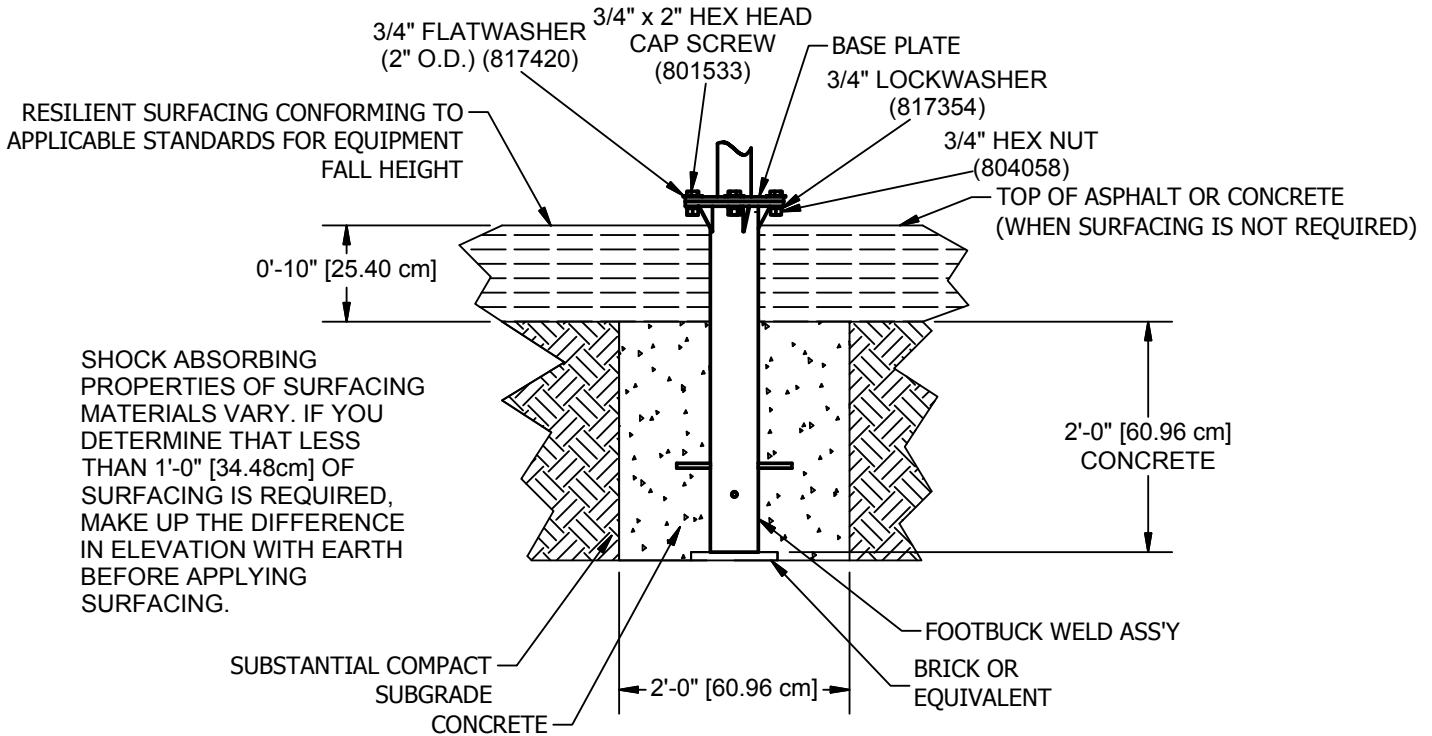

IN GROUND DETAIL

CONCRETE REQUIRED:
.30 CUBIC YARDS
.23 CUBIC METERS

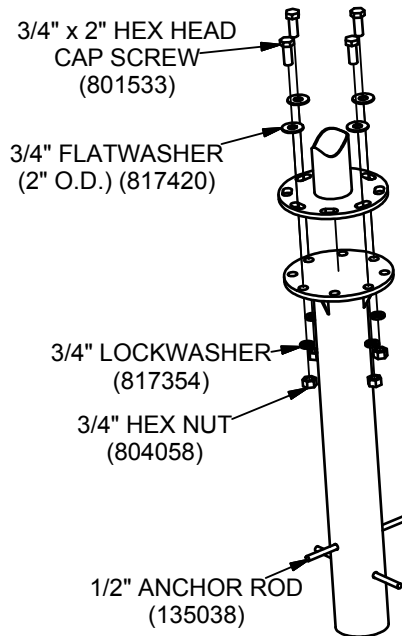

**IN GROUND ASSEMBLY DETAIL
UP165S (IN GROUND)**

NOTE:

- RESILIENT SURFACING AND SUBSTANTIAL COMPACTED SUBGRADE DEPTHS DEPEND ON SOIL CONDITIONS AND RESILIENT SURFACING TYPE.
- SLOPED FOOTING (45° MIN) IS A REQUIREMENT OF EUROPEAN STANDARD EN1176-1 ONLY.
- SUGGESTED MINIMUM CONCRETE RATING 3000 PSI.

Issued/Revised: 01/24/17



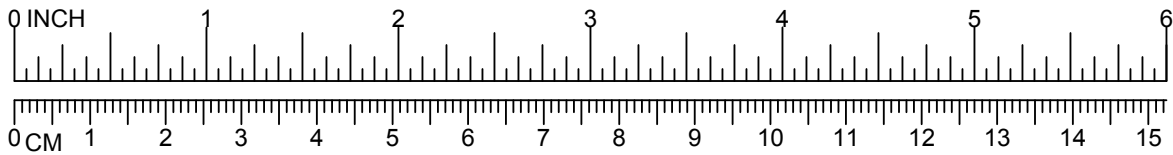

**UP165J LAT PULL DOWN (FOOTING)
 UP165S LAT PULL DOWN (IN GROUND)
 UP165SM LAT PULL DOWN (SURFACE)**

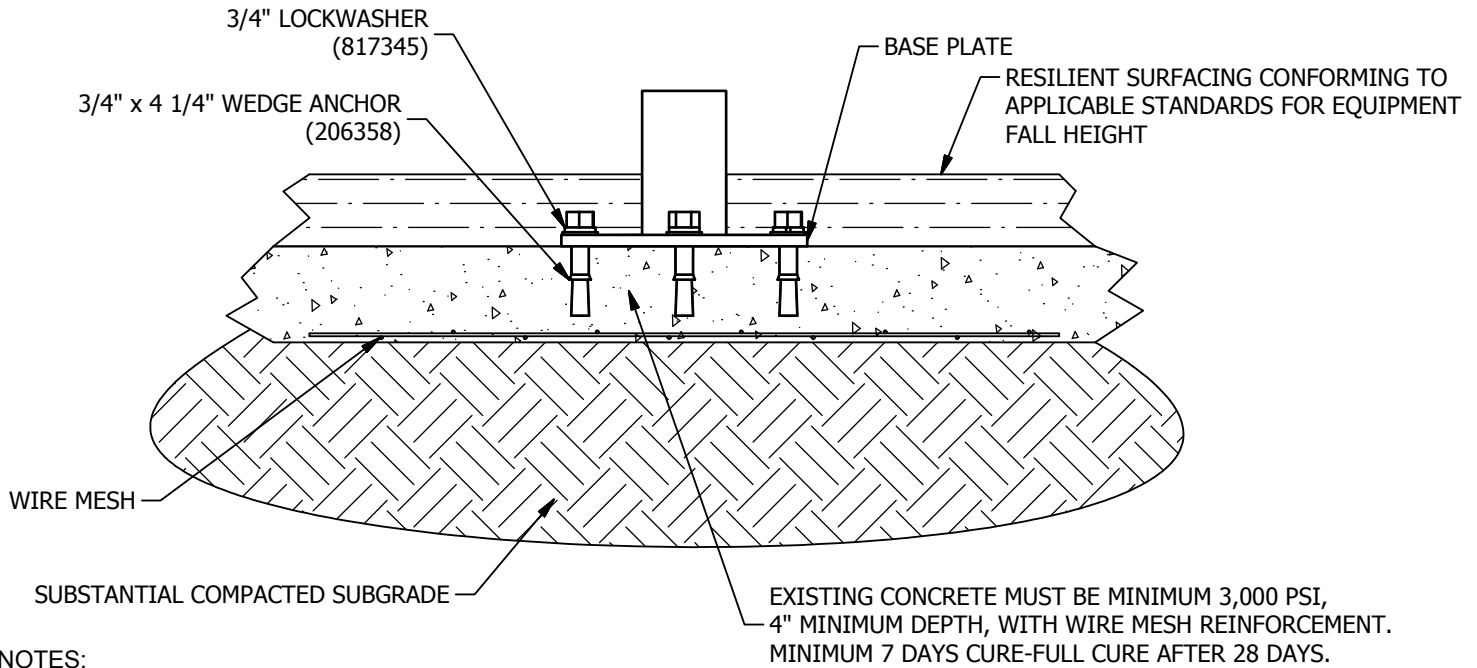

NOTES:

-LOOSE FILL SURFACING NOT RECOMMENDED FOR SURFACE MOUNT.

-RESILIENT SURFACING AND SUBSTANTIAL COMPACTED SUBGRADE DEPTHS DEPEND ON SOIL CONDITIONS AND RESILIENT SURFACING TYPE.

**SURFACE DETAIL
 UP165SM (SURFACE)**

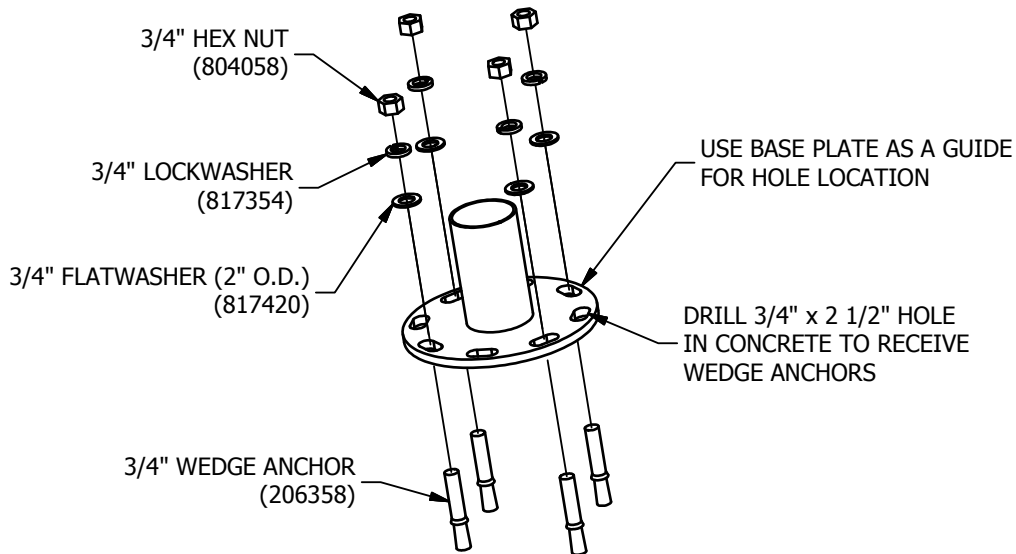

**SURFACE ASSEMBLY DETAIL
 UP165SM (SURFACE)**

Issued/Revised: 01/24/17



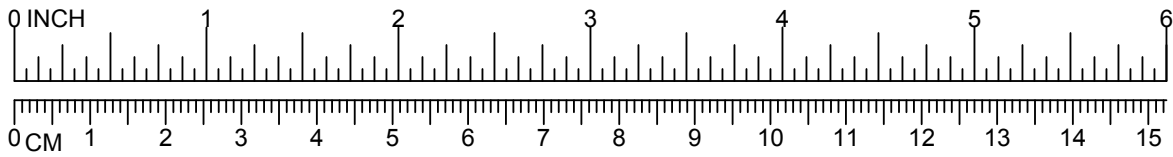

**UP165J LAT PULL DOWN (FOOTING)
UP165S LAT PULL DOWN (IN GROUND)
UP165SM LAT PULL DOWN (SURFACE)**

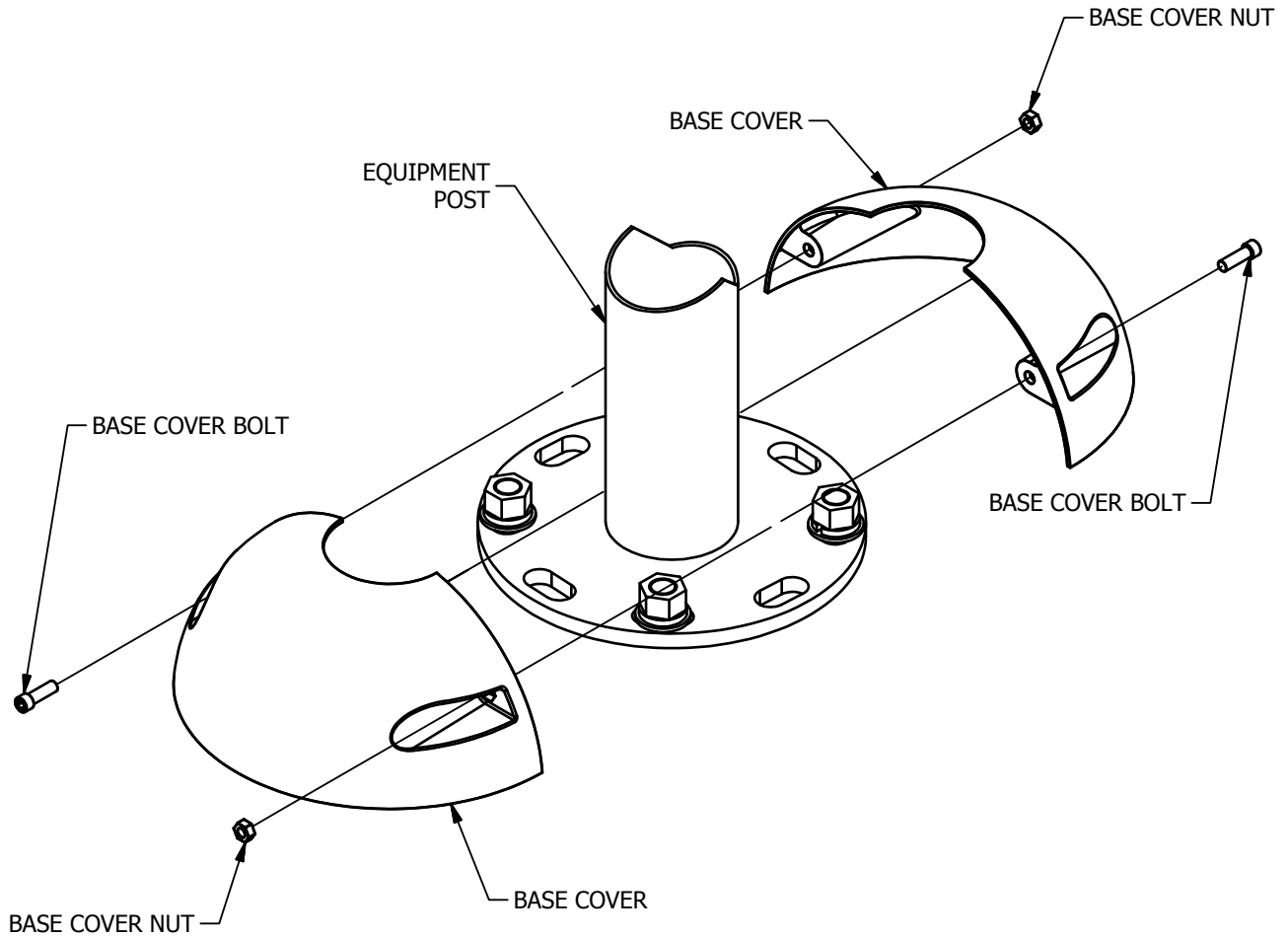

NOTE:
BASE COVER BOLT AND
BASE COVER NUT ARE INCLUDED
WITH BASE COVER.

BASE COVER DETAIL

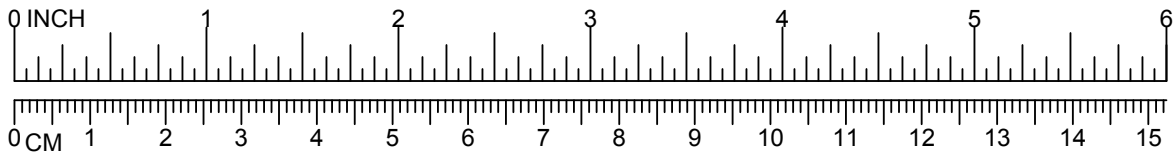

**UP165J LAT PULL DOWN (FOOTING)
UP165S LAT PULL DOWN (IN GROUND)
UP165SM LAT PULL DOWN (SURFACE)**

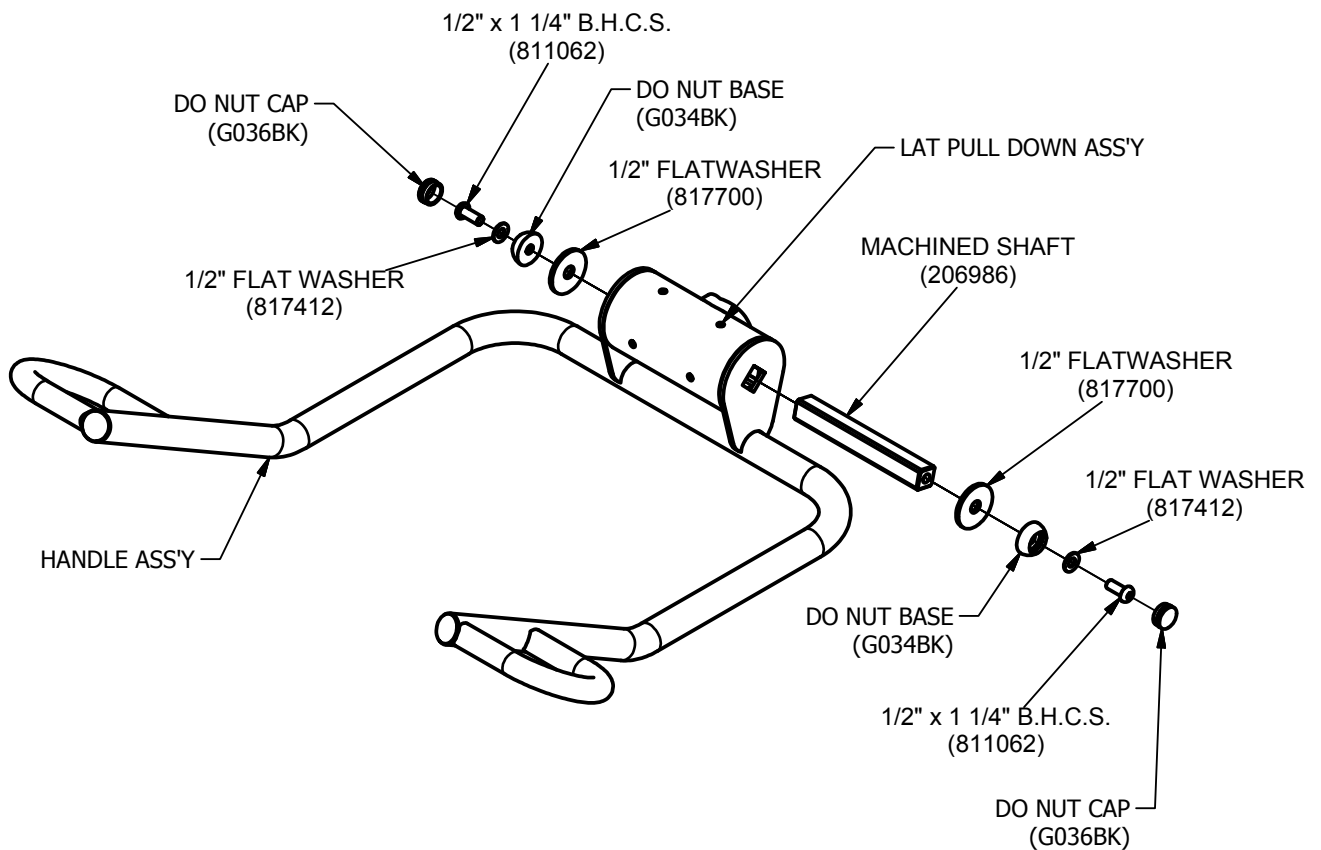

HANDLE ASSEMBLY DETAIL

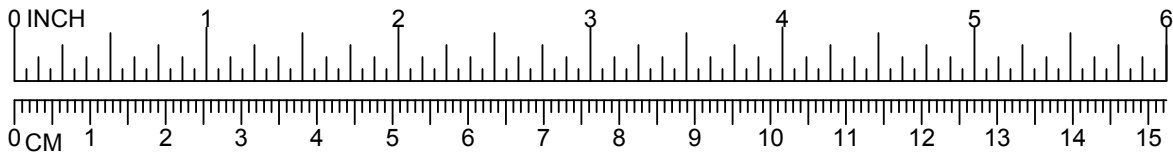

UP165J LAT PULL DOWN (FOOTING)
UP165S LAT PULL DOWN (IN-GROUND)
UP165SM LAT PULL DOWN (SURFACE)

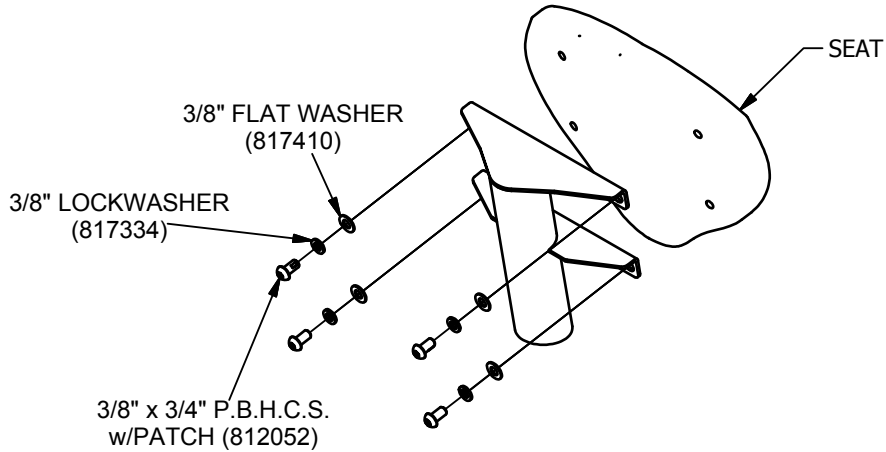

SEAT DETAIL

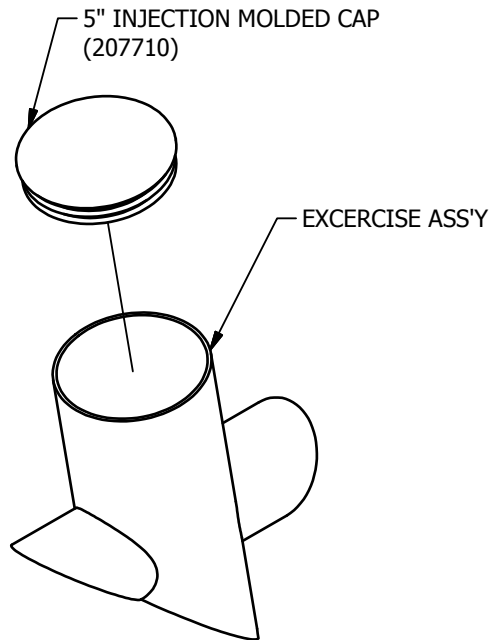

5" CAP DETAIL