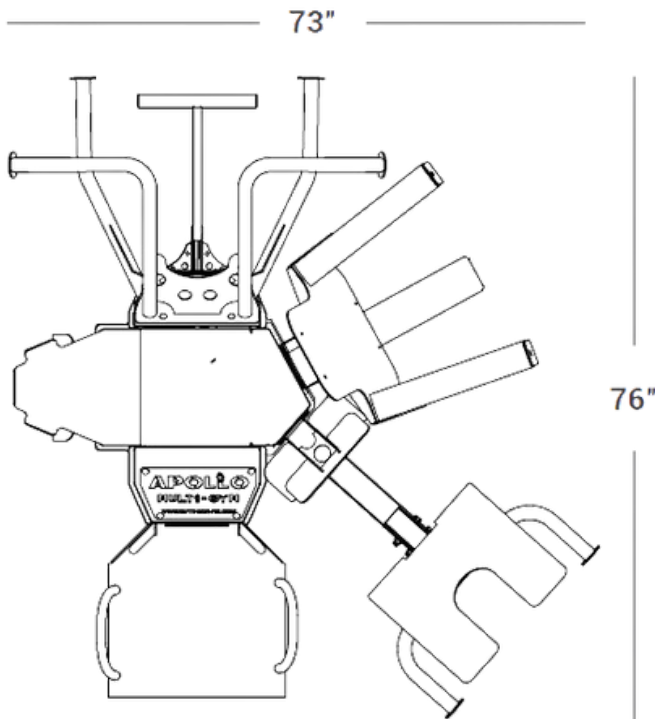

Apollo Multigym

KEY FEATURES

- ✓ Five (5) users
- ✓ Five (5) stations
- ✓ 19+ full-body exercises
- ✓ Weatherproof and tamperproof
- ✓ 15-year warranty

**APOLLO**
MULTIGYM

TECHNICAL SPECIFICATIONS

Height: 85" (216 cm) **Fall Height:** 84" (213 cm)
Width: 73" (185 cm) **Use Zone:** 14" x 13" (36 cm x 33 cm)
Length: 76" (193 cm) **Weight:** 1046 lbs. (475 kg)

Shipping Dimensions: 44" (112 cm) W x 76" (193 cm) L x 85" (216 cm) H
Shipping Weight: 1206 lbs. (547 kg)

Instructional Placards: Reverse print with UV-stabilized ink on 1/4" thick Lexan. Bolted to the columns with a stainless steel trim ring using stainless steel carriage bolts.

Frame: Constructed of 3/16" and 1/4" thick heavy-duty steel. All fasteners are tamperproof stainless steel carriage bolts with a smooth, rounded head and square neck. The locking nuts are shielded behind a padlocked access hatch.

Finish:

- All parts have surfaces prepped and cleaned of all mill scale, rust, oils, and dirt using shot blast and/or chemical wash
- Primer coat is applied with epoxy zinc-rich primer (3-4 mil thickness) and cured in oven
 - Primer designed for superior rust protection. Tested for 3000 hours of salt spray resistance
- Top finish coat is applied with TGIC-FREE weather-resistant polyester powder (3-4 mil thickness) and cured in oven
 - Tested for 1500 hours of salt spray resistance
- All parts inspected to be free of paint defects prior to shipping

Accessibility: It is the manufacturers' opinion that the Apollo Multigym conforms to the A.D.A. accessibility standard, assuming an accessible protective surfacing is provided, or within the entire use zone.

High Low Pulley System

- 100 lbs weight stack with stainless selector pin that travels within a contained security track
- Adjustable weight stack in 10 lbs increments
- 1/2" thick Lexan gate covering weight stack
- Locking lever activates to prevent pinch points and crush zones
- Instructional placard with graphics and QR codes for fitness programming and how-to videos
- Exercises available:
 - Tricep Press Down
 - Upper Back Pull Down
 - Kneeling Cable Crunch
 - Single Arm Chest Press
 - Bicep Curl
 - Back Seated Row
 - Upright Shoulder Row
 - Cable Squat
 - + More

16" Plyo Platform

- Steel non-slip diamond treadplate
- Integrated horizontal and vertical support handles made of 1" thick tubing
- Instructional placard with graphics and QR codes for fitness programming and how-to videos
- Exercises available:
 - Plyo Step Ups
 - Elevated Knee Touches
 - Seated Crunches
 - Box Jumps
 - Bulgarian Squat
 - Incline Push-ups
 - + More

Vertical Abdominal Knee Raise

- Back pad is angled properly and ergonomically
- Rubber forearm pads
- Instructional placard with graphics and QR codes for fitness programming and how-to videos
- Exercises available:
 - Straight Leg Raise
 - Bent Leg Raise

Adjustable Back Extension Bench

- Adjusts at four different points for people of different heights
- Instructional placard with graphics and QR codes for fitness programming and how-to videos
- Exercises available:
 - Lower Back Extension

Calf Raise

- Square aluminum non-slip treadplate
- Instructional placard with graphics and QR codes for fitness programming and how-to videos
- Exercises available:
 - Single-leg calf raises
 - Double-leg calf raises

Chin-Up & Dip Bars with Assist Mechanism

- Adjustable stainless steel assist lever that removes between 60 & 120 lbs of the user's body weight.
 - Four (4) assist settings: 60lbs – 80lbs – 100lbs - 120lbs
- Instructional placard with graphics and QR codes for fitness programming and how-to videos
- Exercises available:
 - Wide Grip Chin-up (with or without assist)
 - Narrow Grip Chin-up (with or without assist)
 - Hammer Grip Chin-up (with or without assist)
 - Dips (with or without assist)

End of comprehensive technical specifications.