

**Spectra Clean Series, Wildcat E 1.5,
part number 10610-00**

The portable filtration system shall consist of the following components:

Cart

The portable filtration system cart shall be constructed of 1.25" x .065" wall thickness stainless steel. All metallic components shall be passivated for maximum corrosion resistance. The cart shall be fitted with two (2) 13" pneumatic wheels.

Filter

A stainless steel filter canister shall be provided with the portable filtration system. It shall be designed to receive a 155 square foot single cartridge filter and shall have a removable lid.

Pump

A 1 1/2 horsepower Sta-Rite® Dyna-Max pump shall be provided. It shall pre-plumbed to the filter canister and mechanically fastened to the cart. It shall be pre-wired with a 100' electrical cord, GFI shock protector, and 220 Volt AC switch.

2" shut off valves and quick-connect hose fittings shall be provided with the unit.

Warranty

Two year limited warranty.

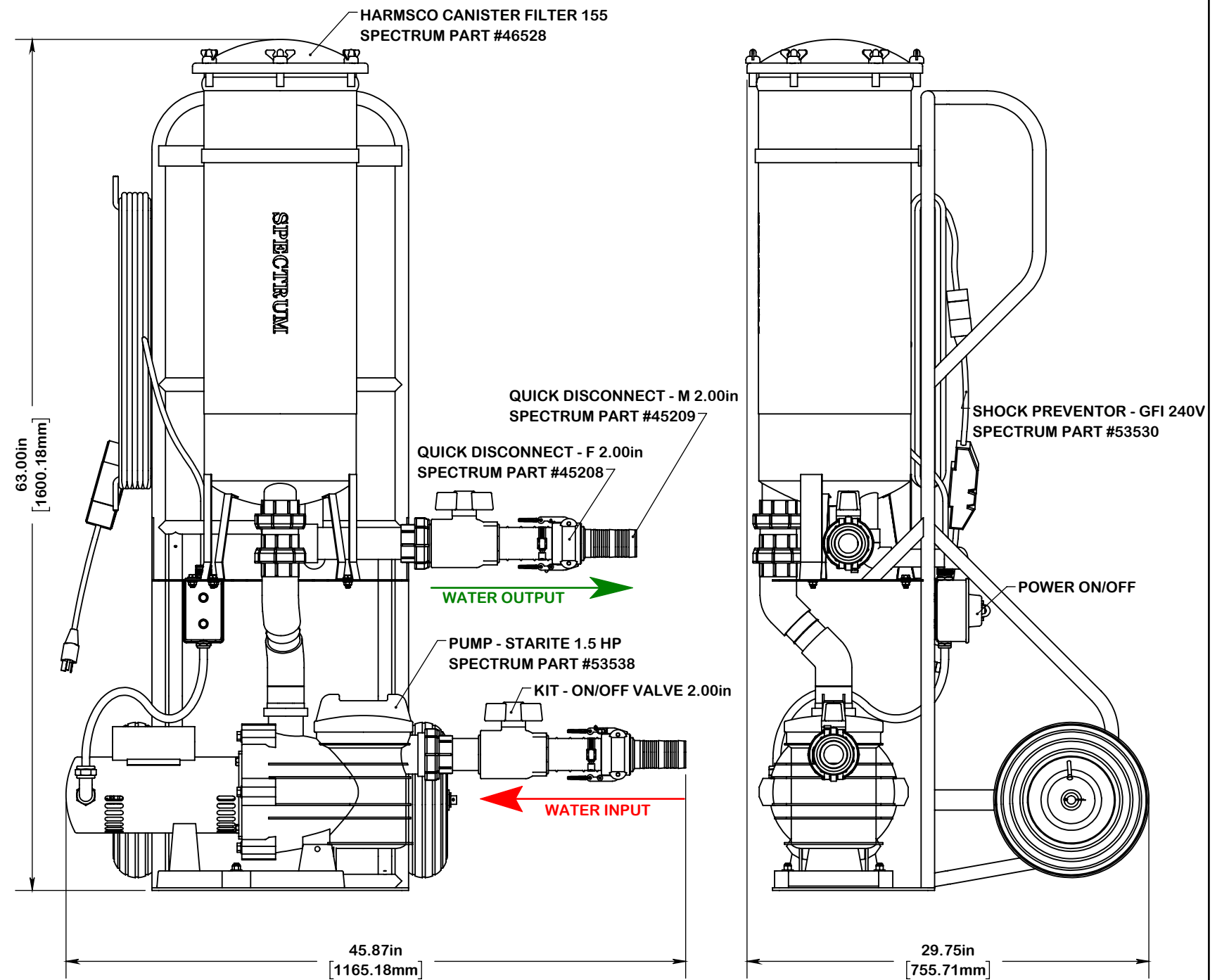

A PLAYCORE Company

7100 Spectrum Lane Missoula, Montana 59808
800.791.8056 www.spectrumaquatics.com

ENGINEERING DATA

PRODUCT:	WILDCAT E1.5 - 10610 -			
MODEL #:	10610	CATALOG #:	10610	REVISION: A
MATERIAL:	304L STAINLESS STEEL			
FINISH #:	600 GRIT			

NOTE:

⚠ DIMENSIONS VARY WITH SPECIFIC APPLICATIONS. SPECIFICATIONS ARE NOMINAL AND ARE SUBJECT TO CHANGE. PLEASE CONTACT SPECTRUM AQUATICS FOR CUSTOM APPLICATIONS