

Lolo Gallatin Retrofit Anchor

Part Number 27400

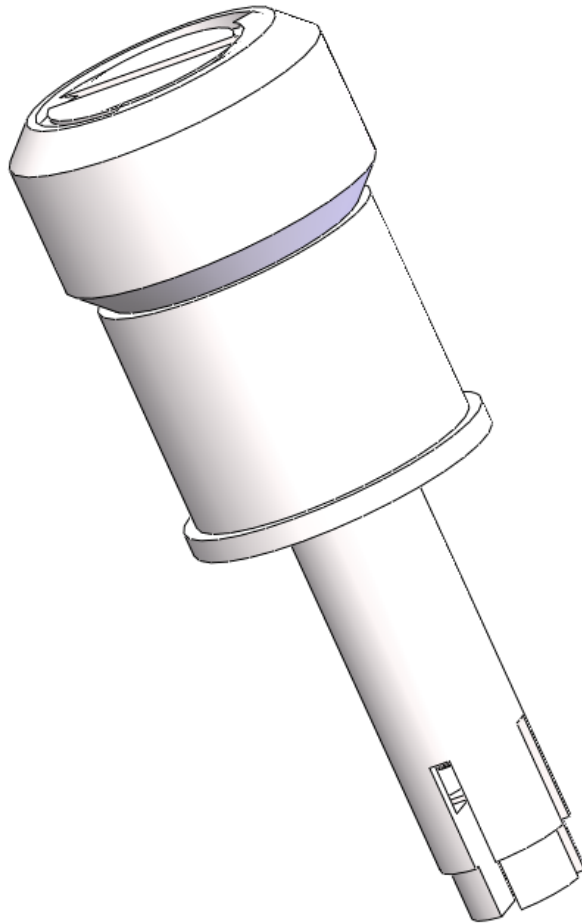

7100 Spectrum Lane ~ Missoula MT 59808
800.791.8056 ~ www.spectrumproducts.com

27400 Man Rev D

The Swim-Lift® Gallatin and Lolo have been designed to fit on a variety of gutter/pool/spa wall configurations. The Lolo lift will accommodate swimming pool “only” installations, while the Gallatin will accommodate swimming pool and/or spa installations.

It is recommended that a licensed contractor install the lift anchor assembly.

Installation Location

To install the Retrofit anchor assembly, select a location that will allow the user space to access the lift. Be aware, specific codes and regulations dictate the required access deck space. The ADA Accessibility Guidelines, subsection 1009.2.3 Clear Deck Space, stipulates: “On the side of the seat opposite the water, a clear deck space shall be provided parallel with the seat. The space shall be 36-inches (0.91m) wide minimum and shall extend forward 48-inches (1.22m) minimum from a line located 12-inches (0.3048m) behind the rear edge of the seat. The clear deck space shall have a slope not steeper than 1:48.”

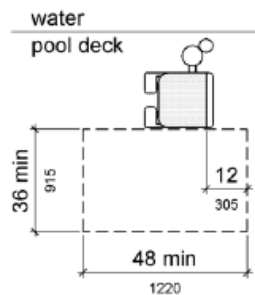

Figure 1009.2.3 Clear Deck Space at Pool Lifts

The water depth required for the installation of the Swim-Lift® Gallatin and Lolo is 38-inches (0.97m), minimum. This dimension is in compliance with the ADA Accessibility Guidelines, subsection 1009.2.8 Submerged Depth, which stipulates: The lift shall be designed so that the seat will submerge to a water depth of 18-inches (0.46m) minimum below the stationary water level.” The 38-inches (0.97m) minimum dimension accommodates the seat and footrest.

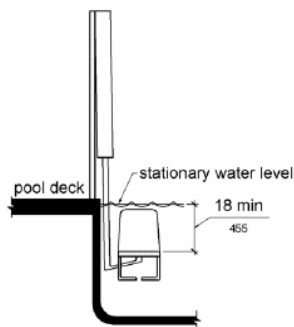

Figure 1009.2.8 Pool Lift Submerged Depth

The Gallatin is design to accommodate installation on spas. Spas normally have a bench that may interfere with the installation of a lift (Lolo). The Gallatin will accommodate the majority of spa installations. The spa bench seat cannot extend into the spa beyond 16-inches (0.41m) and must be 24 1/8-inches (0.65m), minimum, below the surface to accommodate the Gallatin.

Installation Procedure

Gallatin

The setback distance (Figure 1), or distance from the finished pool wall, to the centerline of the Gallatin anchor assembly can be between 20 1/2-inches (0.52m) and 30-inches (0.76m). The recommended setback distance is 24-inches (0.61m).

Lolo

The setback distance (Figure 1), or distance from the finished pool wall, to the centerline of the Lolo anchor assembly can be between 23-inches (0.58m) and 25-inches (0.64m). The recommended setback distance is 24-inches (0.61m).

Gallatin and Lolo

Mark the location of each anchor socket on the deck using a marking pen or chalk. Make sure each anchor is located at the same distance from the pool edge. The anchors must be spaced 2' 5 5/8" apart from center of anchor to center of anchor. (Figure 1) The individual anchors may not be placed within 6-inches (15.24cm) of any concrete joint or other similar obstruction.

Use a 1/2" diameter concrete drill bit to drill a 3-3/4" deep hole at each location. (You can use a piece of tape wrapped around the drill bit at 3-3/4" high on the bit to tell you when you have reached the required depth).

NOTE: These holes must be drilled at a perfectly perpendicular angle to the pool deck.

Use a 1-1/2" diameter concrete core drill to drill out the anchor holes to a depth of 2". (Again you can use a piece of tape to mark the depth on your bit). Clean out all the debris from the holes. Verify that the bottom and sides of the holes are solid and not crumbling. The concrete surrounding each anchor must be solid and in good condition in order to secure the anchors. The top of the anchors should be no more than 1/8" below the deck surface, but the anchor can be installed slightly deeper if necessary to mount into solid concrete.

Remove the expansion bolt from each anchor and set each one at the bottom of each hole by tapping the anchor wedge with a 5/16" diameter set tool rod and a hammer. Once in final position, give each anchor a final sharp tap to set the anchor into the concrete.

Thread the 3/8"-16 hex head bolts into the expansion anchors through the bottom of the female ACME nut. Pour a sufficient amount (approximately 50ml) of two-part epoxy in

each anchor hole to fill it about 1/3 full and then immediately drop in the 1" female ACME nut into each hole.

Tighten the 3/8"-16x1" hex head bolts with a 9/16" deep well socket to approximately 30 ft-lbs torque.

Allow sufficient time for the epoxy and/or cement to completely harden before installing the lift. 24 hours is recommended.

A bonding clamp is supplied with the retrofit anchor kit. Attach the bonding clamp to any metal fixture near the lift that is known to be bonded. Run a #8 copper wire between the bonding clamp and the bonding bolt on the base stand of the lift. Also see the instructions supplied with the bonding clamp.

Note: Bonding is required by the National Electrical Code (NEC 680-22)

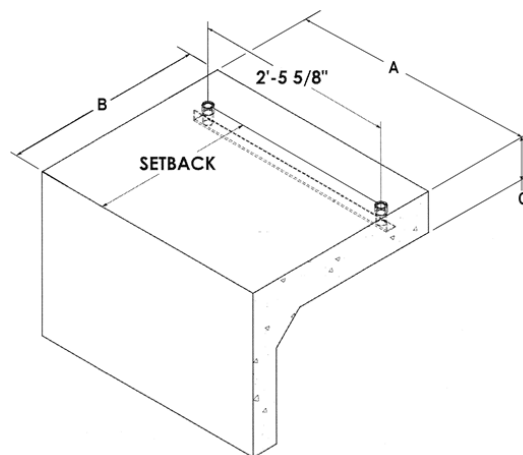

Figure 1

Note: Concrete mass required necessary to support the maximum loads indicated:

Lolo, 400-Pound Capacity (see Figure 1)

1. A - width 7-feet (2.13m), B - depth 4-feet (1.22m), C - thickness 4-inches (10.16cm)
2. A - width 5-feet (1.52m), B - depth 4-feet (1.22m), C - thickness 6-inches (15.24cm)

Gallatin, 400-Pound Capacity (see Figure 1)

1. A - width 10-feet (3.05m), B - depth 5-feet (1.52m), C - thickness 4-inches (10.16cm)
2. A - width 7-feet (2.13m), B - depth 4 ½-feet (1.37m), C - thickness 6-inches (15.24cm)