



The APOLLO-NA has established a track record of reliability and excellence, making it a go-to choice in correctional facilities and bustling outdoor fitness parks.

## Real Fitness Equipment for Real Results

The APOLLO-NA Multigym brings the fundamentals of indoor commercial fitness equipment to outdoor environments in a tamper-proof, durable, and weather-proof package.

Compact, cost-effective, and secure with minimal moving parts, make the APOLLO-NA a part of your next project.



 **TAMPERPROOF.**  **WEATHERPROOF.**  **SAFE.**

### POPULAR PULLEY STATION

The APOLLO-NA features the popular HI-LO pulley station for a variety of standing or seated exercises. Our unique, tamperproof selectorized weight stack allows users to adjust weight between 10 and 100lbs. Locking safety features also eliminate pinch points or entrapment zones typically seen on selectorized weight stack systems.

### NO ASSIST MECHANISM

The APOLLO-NA eliminates the assist arm, giving you unobstructed access to pull-ups and dips. For users needing assistance with these exercises, the integrated static assist lip comes into play. With the same user and exercise capabilities as the standard APOLLO, the APOLLO-NA stands as a comparable choice.

### 19+ DIFFERENT EXERCISES

The APOLLO-NA is designed with over 19 different exercises, to five simultaneous users. With exercises that target every muscle group, the APOLLO-NA provides a full-body workout for every fitness level, age, and ability.



1-877-760-6337 · info@outdoor-fit.com · www.outdoor-fit.com



# The APOLLO-NA is built to maximize indoor or outdoor exercise areas, with over 19 exercises available and few moving parts:

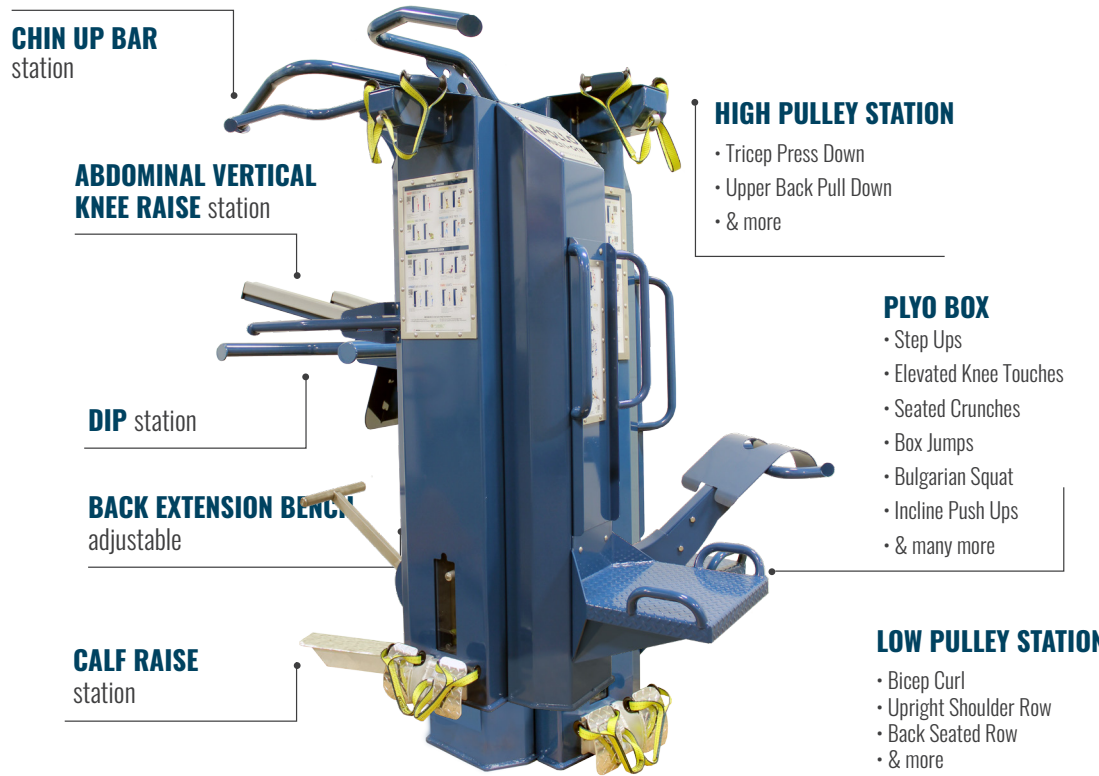

## TECHNICAL SPECIFICATIONS



**Width:** 73" / 185 cm

**Length:** 76" / 193 cm

**Height:** 85" / 216 cm

**Use Zone:** 13'10" x 12'6"

**Weight:** 846 lbs / 383 kg

**Fall Height:** 84" / 213cm

**Weight Stack Weight:** 100 lbs / 45 kg

**Shipping Weight:** 1006 lbs / 456 kg

**Shipping Dimensions:** 44" wide x 76" long x 85" high /  
112 cm wide x 193 cm long x 216 cm high



### CAD DRAWING

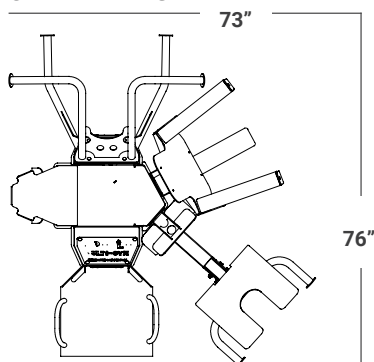

**APOLLO<sup>+</sup>NA**  
MULTIGYM



**Instructional Placards:** Reverse print with UV-stabilized ink on 1/4" thick Lexan. Bolted to the columns with a stainless steel trim ring using stainless steel carriage bolts.

**Frame:** Constructed of 3/16" and 1/4" thick heavy-duty steel. All fasteners are tamperproof stainless steel carriage bolts with a smooth, rounded head and square neck. The locking nuts are shielded behind a padlocked access hatch.

#### Finish:

- All parts have surfaces prepped and cleaned of all mill scale, rust, oils, and dirt using shot blast and/or chemical wash.
- Primer coat is applied with epoxy zinc-rich primer (3-4 mil thickness) and cured in oven.

Primer designed for superior rust protection. Tested for 3000 hours of salt spray resistance.

- Top finish coat is applied with TGIC-FREE weather-resistant polyester powder (3-4 mil thickness) and cured in oven.
- Tested for 1500 hours of salt spray resistance.
- All parts inspected to be free of paint defects prior to shipping.



**Accessibility:** It is the manufacturers' opinion that the Apollo-NA Multigym conforms to the A.D.A. accessibility standard, assuming an accessible protective surfacing is provided, or within the entire use zone.