

APOLLO

MULTIGYM

With a proven history of durability and performance, the APOLLO is becoming a favorite of correctional facilities as well as busy outdoor fitness park installations.

Real Fitness Equipment for Real Results

The APOLLO Multigym takes the basics of indoor commercial fitness equipment and delivers it to the outside world in a tamperproof, durable, and weatherproof package.

Compact, cost effective, and completely safe, the APOLLO is designed for any fitness level or ability.



 **TAMPERPROOF.**  **WEATHERPROOF.**  **SAFE.**

POPULAR PULLEY STATION

The APOLLO features the popular HI-LO pulley station for a variety of standing or seated exercises. Our unique, tamperproof selectorized weight stack allows users to adjust weight between 10 and 100lbs. Locking safety features also eliminate pinch points or entrapment zones typically seen on selectorized weight stack systems.

19+ DIFFERENT EXERCISES

The APOLLO is designed with over 19 different exercises, offering a full body workout.

With adjustability where needed and our unique chin/dip assist mechanism, the APOLLO Multigym is suitable for users of all fitness levels.

5 SIMULTANEOUS USERS

The APOLLO helps you make the most of your space, with up to five people using the equipment at once.

The APOLLO is built to maximize indoor or outdoor exercise areas, with over 19 exercises available:

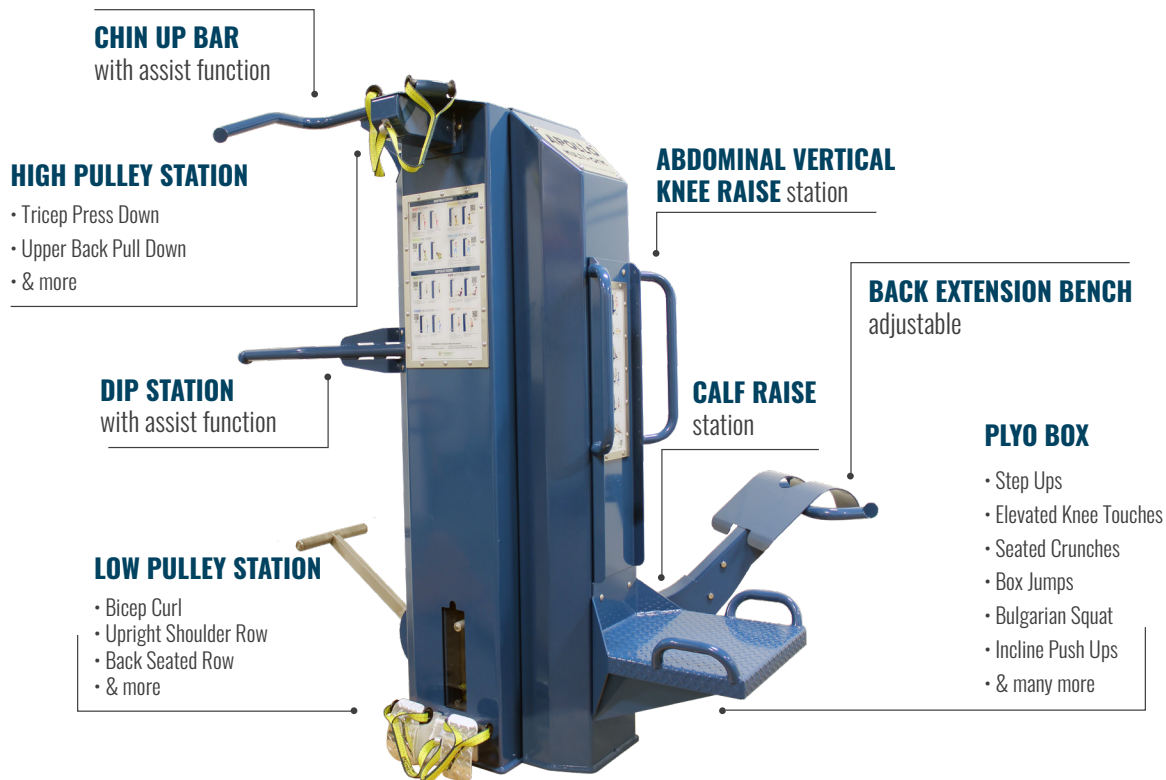

TECHNICAL SPECIFICATIONS



Width: 73" / 185 cm

Length: 76" / 193 cm

Height: 85" / 216 cm

Use Zone: 13'10" x 12'6"

Weight: 1046 lbs / 475 kg

Fall Height: 84" / 213cm

Weight Stack Weight: 100 lbs / 45 kg

Shipping Weight: 1176 lbs / 534 kg

Shipping Dimensions: 48" wide x 72" long x 85" high /
122 cm wide x 183 cm long x 216 cm high



CAD DRAWING

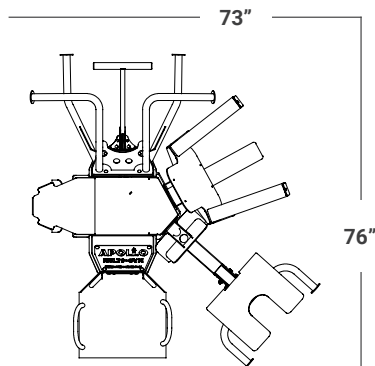

APOLLO
MULTIGYM



Instructional Placards: Reverse print with UV-stabilized ink on 1/4" thick Lexan. Bolted to the columns with a stainless steel trim ring using stainless steel carriage bolts.

Frame: Constructed of 3/16" and 1/4" thick heavy-duty steel. All fasteners are tamperproof stainless steel carriage bolts with a smooth, rounded head and square neck. The locking nuts are shielded behind a padlocked access hatch.

Finish:

- All parts have surfaces prepped and cleaned of all mill scale, rust, oils, and dirt using shot blast and/or chemical wash.
- Primer coat is applied with epoxy zinc-rich primer (3-4 mil thickness) and cured in oven. Primer designed for superior rust protection. Tested for 3000 hours of salt spray resistance.
- Top finish coat is applied with TGIC-FREE weather-resistant polyester powder (3-4 mil thickness) and cured in oven. Tested for 1500 hours of salt spray resistance.
- All parts inspected to be free of paint defects prior to shipping.



Accessibility: It is the manufacturers' opinion that the Apollo Multigym conforms to the A.D.A. Accessibility standard, assuming an accessible protective surfacing is provided, or within the entire use zone.