

SPECIFICATIONS:
 RATED CAPACITY: 400LBS [181KG]
 MAXIMUM SETBACK: 20" [508mm]

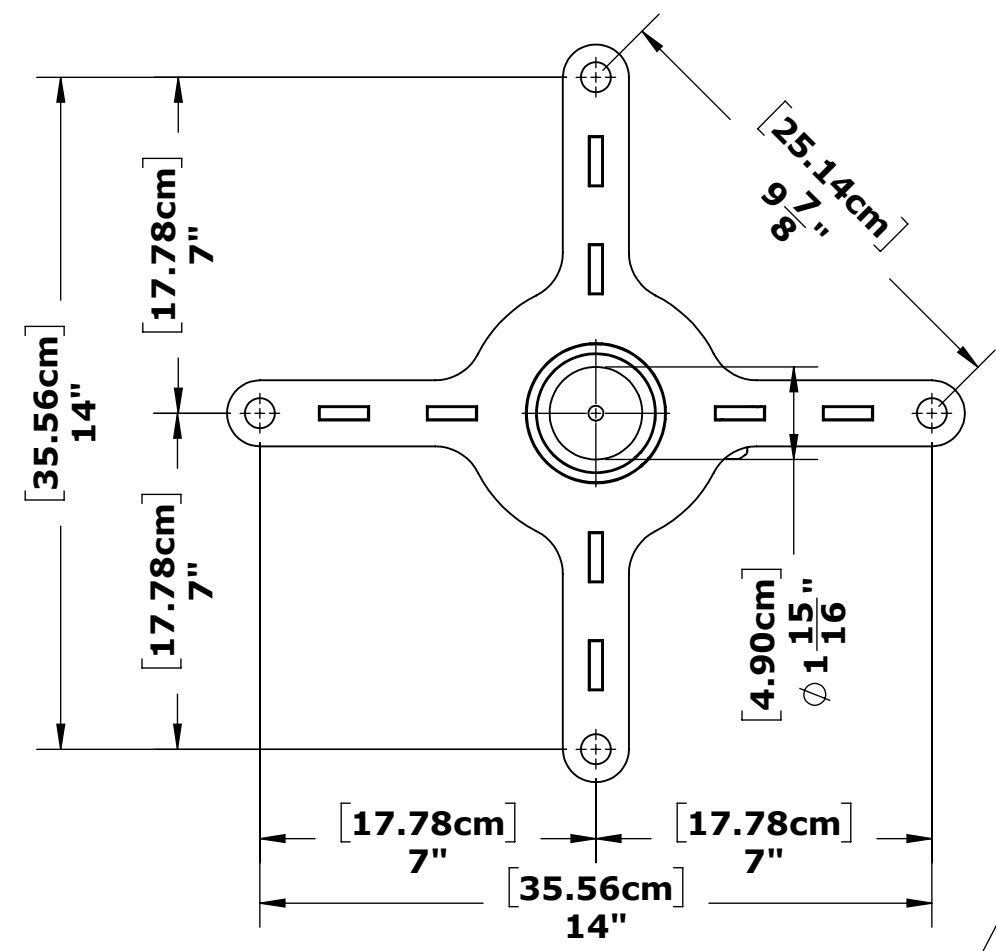

**DUE TO DECK CONSTRUCTION
 CARRIAGE BOLTS AND FASTENERS
 ARE NOT PROVIDED. QUANTITY OF
 04 REQUIRED.**

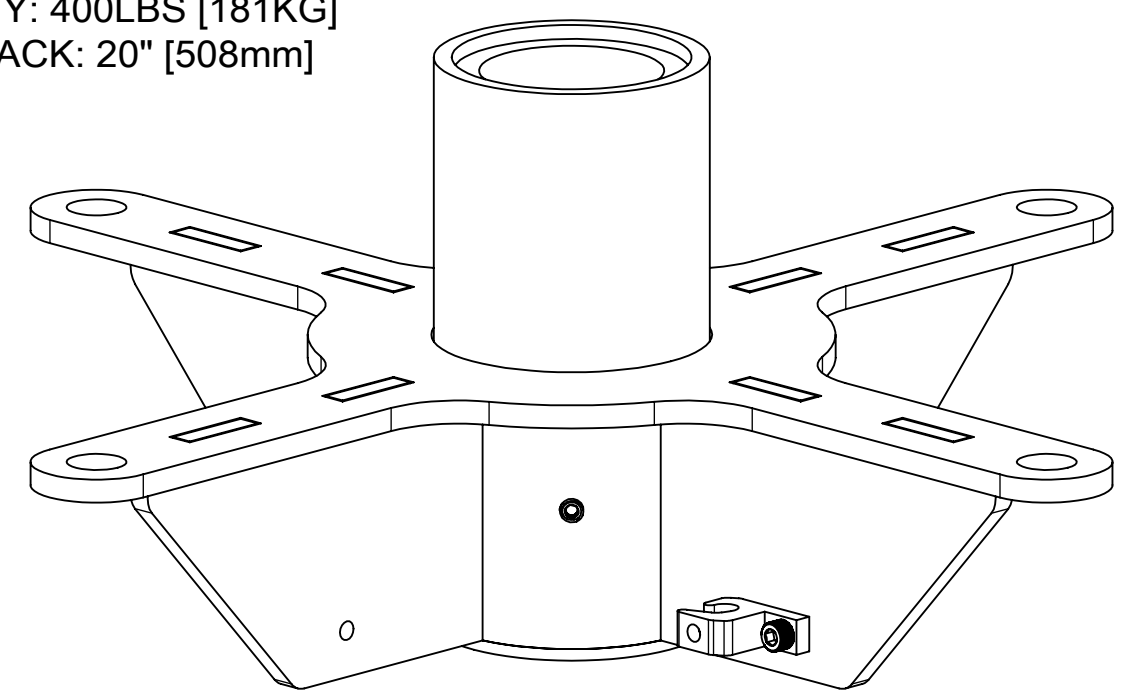
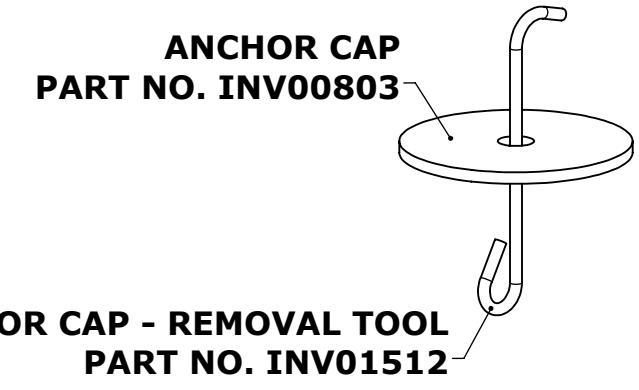
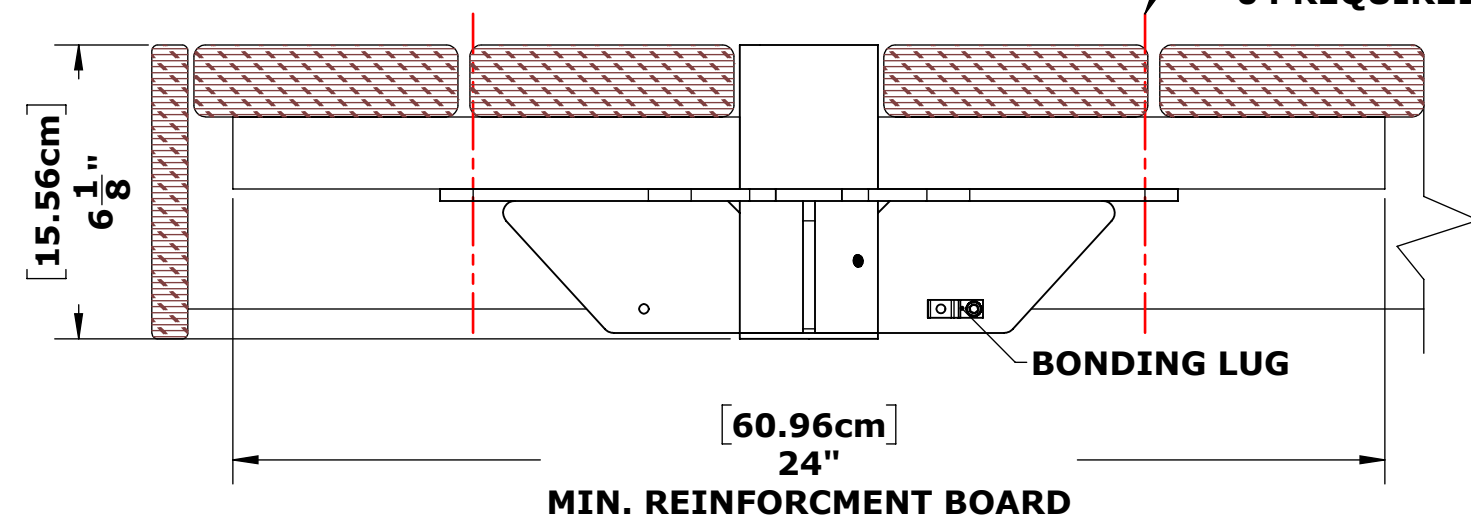

TOLERANCES
 DIMENSIONS ARE IN INCHES
 UNLESS OTHERWISE SHOWN
 FRACTIONAL: ±1/16
 ANGULAR: ±1°
 TWO PLACE DECIMAL: ±.01
 THREE PLACE DECIMAL: .. ±.005

ANCHOR - 1.90"X6.00" - WOOD
F-30600
PART NO. INV01440

MATERIAL: 304 STAINLESS STEEL
FINISH: POWDER COAT - WHITE
APPROX. WEIGHT: 9.79 LBS.



9889 GARRYMORE LANE
MISSOULA, MT 59808
(406) 549-0769
FAX (406) 549-2602
www.AquaCreek.com

PROPRIETARY AND CONFIDENTIAL INFORMATION
 THIS DRAWING AND ALL INFORMATION CONTAINED HEREIN
 IS THE SOLE PROPERTY OF AQUA CREEK PRODUCTS LLC. ANY
 REPRODUCTION IN PART OR AS A WHOLE WITHOUT WRITTEN
 PERMISSION FROM AQUA CREEK IS PROHIBITED.

| REVISIONS | | | |
|-----------|-----------------|----------|-----------|
| REV. | DESCRIPTION | DATE | APPROVED |
| P1 | INITIAL RELEASE | 6/2/2021 | J.MAXWELL |