

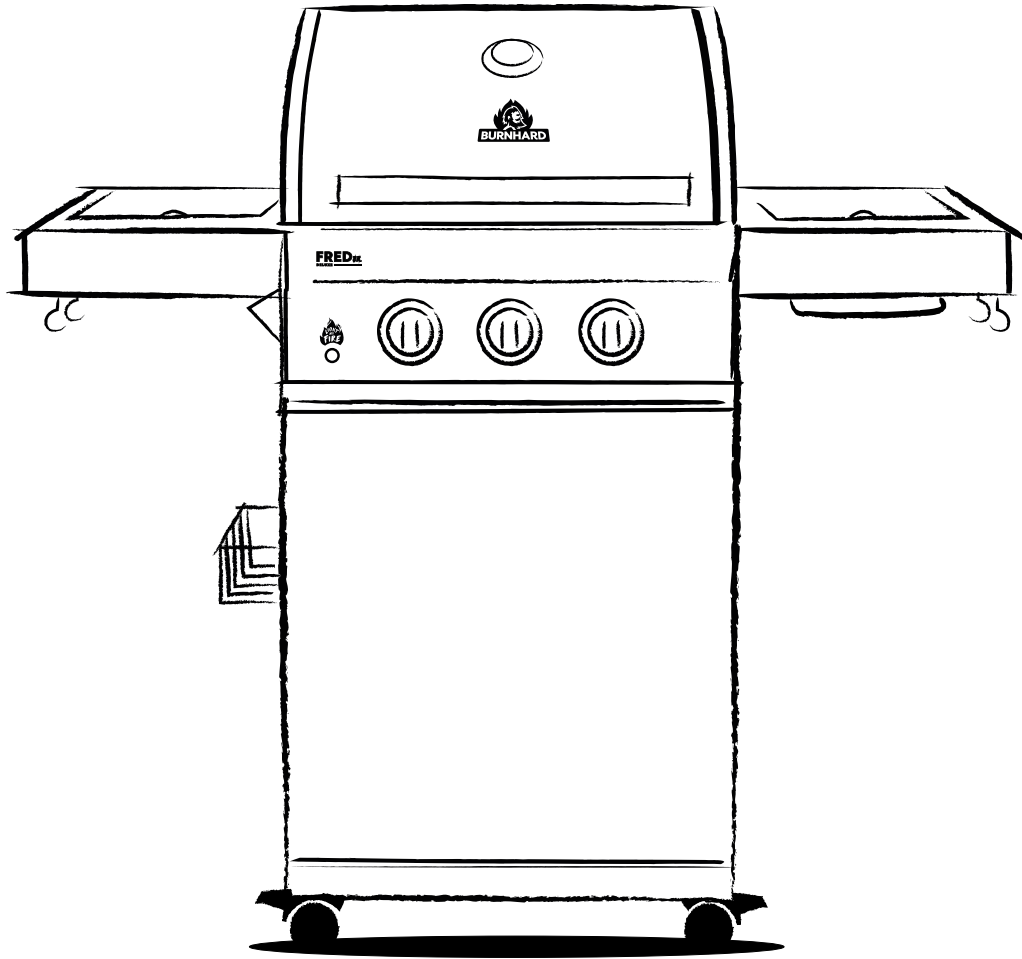

BURNHARD



2-BRENNER GASGRILL

FRED JR.
DELUXE

2-BURNER GAS GRILL FRED JR. DELUXE

CONTENT

2-BURNER GAS GRILL FRED JR. DELUXE

Technical specifications	32
Safety instructions	32
Parts included/Description of components	36
Assembling the gas grill	39
Connecting the gas cylinder	49
Operating the gas grill	51
Cleaning the gas grill	53
Regular maintenance	56
Troubleshooting	57
Storing the gas grill	58
Customer service	58
Disposal/Recycling	58
Declaration of conformity	58

TECHNICAL SPECIFICATIONS

Power:	Total 10,5 kW – 2 main burners with 3.5 kW, 1 infrared ceramic burner with 3.5 kW (in the side table)
Dimensions (W/H/D):	116 x 118 x 55 cm
Weight:	ca. 38 kg
Nominal heat load	
(Hs) Burner:	10,5 kW
Connected load	
Burner:	764 g/h
Operating pressure:	50 mbar
Type of gas:	butane (G30) and propane (G31)
Appliance class:	I3B/P(50)
Includes:	2 stainless steel burners, 1 infrared ceramic burner (in the side table), 2 grill grids, warming grid, food container with wooden cutting board, lid thermometer, piezo ignition
Accessories:	gas hose and pressure regulator (50 mbar), spice and sauce holder, 4 hooks, bottle opener, smoker box, cover

Subject to changes and errors in features, technology, colours, and design.

EXPLANATION OF SYMBOLS



This symbol warns of hazards that can damage the device or cause injury.

SAFETY INSTRUCTIONS

Read the instructions before using the appliance.

INTENDED USE

This gas grill may only be used outdoors and in well-ventilated areas. Never use the gas grill inside a building, garage, or any other enclosed area.

General hazards



- Danger to children or persons with limited ability to operate equipment. This appliance is not intended for use by children or persons with limited ability to operate equipment. The appliance may only be used by persons who are able to operate equipment safely.
- **WARNING:** Accessible parts may be very hot. Keep young children away.
- Do not modify the appliance in any way. Any changes to the appliance can lead to accidents and invalidate the warranty.

UNPACKING THE DEVICE

Danger to children. Danger to life through suffocation/ingestion. Keep the packaging material away from children. Dispose of it immediately. Keep small parts out of their reach.

CONNECTING THE GAS SYSTEM



Fire and explosion hazard

- This gas grill may only be operated with a suitable pressure regulator. The enclosed pressure regulator is set correctly at the factory for liquid gas operation.
- The gas hose may need to be replaced if corresponding national requirements require it.
- Make sure that there is no ignition source, open fire, or similar nearby when replacing the gas cylinder.
- Ask for advice when buying or renting the gas cylinder from a store.
- The device must be connected as described in this manual. Make sure the gas hose is not kinked or chafed.
- Perform the leak test procedure described in this manual (found under CONNECTING THE GAS CYLINDER) before using the grill. Perform the leak test every time you replace the gas cylinder.

GENERAL SAFETY INSTRUCTIONS



Fire and explosion hazard

- Use outdoors only.
- Do not move the appliance during use.
- This appliance must be kept away from flammable materials during use.
- When changing the gas cylinder, care must be taken that there are no combustible materials, children, or pets in the vicinity.
- Improper assembly of the grill may be dangerous. Please follow the assembly instructions carefully.
- This gas grill is not intended for commercial use.
- Do not use charcoal, briquettes or lava rock in your gas grill. The device must not be operated with natural gas.
- Never smoke when handling the gas unit. Do not place the gas cylinder near an open fire.
- Make sure that the gas grill is protected from the wind.
- Keep the grill away from moisture, spraying water, and the like as well as electrical leads.
- This appliance must be kept away from flammable materials during use.
- Set up the gas grill on a flat, stable, and fire-resistant surface.
- Protect the gas cylinder from strong sunlight.
- Check the hose and regulator for tears and damage before each use. Do not use the gas grill if the regulator, gas hose, or cylinder is defective or leaking.
- Before each operation, check the burners for dirt and remove any dirt before operating the gas grill.
- Do not ignite the gas flame with an open flame. Use only the piezo ignition of the respective burner and the electric igniter of the infrared ceramic burner in the side table to ignite it.
- To avoid gas escaping accidentally, the valve on the gas cylinder should only be open when the gas grill is in operation. Close the cylinder valve immediately when you switch off the gas grill.
- Make sure that the housing vents are not covered under any circumstances.
- The surfaces of the gas grill become very hot during operation. Warn bystanders and keep children and pets away.
- While igniting or cooking, never lean over the open grill.
- Always wear protective gloves as soon as the gas grill is in operation and the temperature of the components exceeds the ambient temperature by 50 °C.
- Never leave the gas grill unattended during operation.
- Turn off the gas supply at the gas cylinder after use.
- Before changing the position of the gas grill, the gas unit must be switched off, the gas cylinder valve closed, and the gas cylinder unscrewed from the gas hose to protect the pressure regulator and the hose line.
- Turn off the gas supply at the gas cylinder after use.
- The lid must always be open when the burner is ignited.

MAINTAINING THE GAS GRILL



Fire and explosion hazard

- Repairs and maintenance on the gas unit may only be carried out by authorised specialist personnel. Do not make changes to the gas grill or the pressure regulator.
- Replace the pressure regulator and the hose after 10 years at the latest, even if there is no visible external damage. Make sure that the pressure regulator is approved for the gas used and is set to the correct operating pressure (see TECHNICAL SPECIFICATIONS). A new hose may not be longer than 1.5 m.

MEASURES IN CASE OF GAS ODOUR

- Close the gas supply, extinguish all open flames and open the lid.
- If the smell of gas is still present, keep away from the appliance and inform your gas supplier or the fire brigade.

FIRE-FIGHTING MEASURES

- Get people around you to safety! If possible, close the valve on the gas cylinder. Cool the gas cylinder with water. Pay attention to your safety. Spontaneous, explosive reignition is possible.
- In case of fire, filled pressurized gas containers should be removed from the area threatened by the fire. If this is not possible, the compressed gas containers must be kept from overheating by suitable means, like spraying with water from a protected position.
- If grease fire should break out, try (if possible) to switch off the burners, close the lid until the fire is extinguished.
- **WARNING: Never attempt to extinguish an oil or grease fire with water.** Always use the fire extinguishing agents provided for this purpose: grease fire extinguisher and/or fire blanket. Ask a specialist dealer for specific information on this.
- Keep away from the source of the fire and inform the fire brigade immediately.

FIRST-AID MEASURES

What to do in case of gas inhalation

- Inhaling high gas concentrations can lead to suffocation. Possible symptoms include loss of mobility and unconsciousness. The victim does not realise that he or she is suffocating. If inhaled in low concentrations, the gas can cause dizziness, headaches, nausea, and problems with coordination.
- Move the victim to fresh air. Contact a doctor or rescue service. In case of respiratory arrest, initiate artificial respiration.

What to do in case of severe burns or scalds

- There is an acute risk of hypothermia and shock. Call the emergency services immediately!
- Immediately douse burning clothes with water or smother the flames with a thick blanket.
- Burns: leave clothes on the body.
- In case of scalding: remove clothing immediately.
- Cool the affected area with cold water for at least 15 minutes until the pain subsides.
- Cover the affected area with a sterile Metalline towel. Apply the Metalline-coated side to the injured skin and fix it loosely with a gauze bandage or a triangular cloth.
- Do not use "home remedies" such as ointments, powders, oils, disinfectants, etc.!

Measures for minor burns or scalding

- Burns: remove clothing only if it does not stick to the body.
- In case of scalding: remove clothing immediately.
- Cool the affected area with cold water for at least 15 minutes until the pain subsides.
- Let small burns or scalds that haven't formed blisters heal in the air, do not cover with a patch or bandage.

INSTRUCTIONS FOR TRANSPORT



Fire and explosion hazard

- If possible, do not transport the gas cylinder in vehicles in which the load compartment is not separated from the driver's cab. The driver must be aware of the potential dangers of the cargo and must know what to do in the event of an accident or emergency.
- Transport the gas cylinder upright and secured against falling over and slipping.
- Make sure that the gas cylinder valve is closed tightly.

STORAGE INSTRUCTIONS



Fire and explosion hazard

- Store the gas cylinder out of reach of children.
- Keep the gas bottle away from oxidising gases and other oxidising substances.
- Escaping LPG is heavier than air and sinks to the bottom. Do not store the gas cylinder at home lower than ground level (for example, in the cellar, underground car park, etc.) or in unventilated places where escaping gas could accumulate.
- Protect the gas bottle from direct sunlight and other heat sources. Store the gas bottle at a temperature of less than 50 °C in a well-ventilated, shady place and protected from weather influences.
- Store the gas cylinder upright and secured against falling over.
- Do not store spare / additional or disconnected gas cylinders under or near the gas grill.
- The storage instructions also apply to empty gas cylinders. These still contain a residual amount of LPG.

PARTS INCLUDED/DESCRIPTION OF COMPONENTS

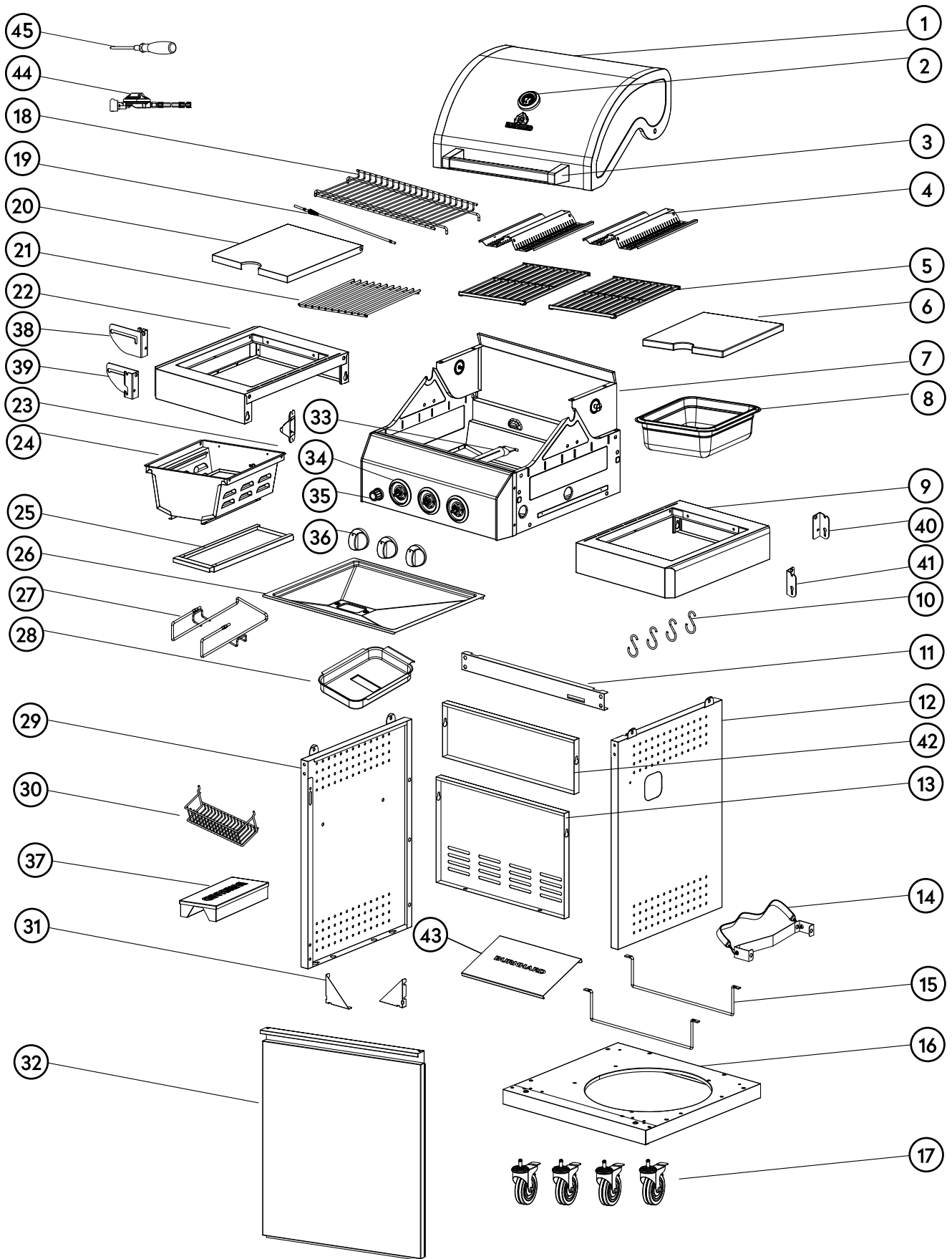

Ref.	Description	Quantity
1	Lid	1
2	Lid thermometer	1
3	Lid handle	1
4	Flame distributor	2
5	Grid	2
6	Wooden cutting board	1
7	Combustion chamber	1
8	Food Container	1
9	Side table (right)	1
10	Accessory hook	4
11	Lower cabinet strut	1
12	Side panel base cabinet (right)	1
13	Rear panel base cabinet	1
14	Gas bottle holder	1
15	Gas bottle suspension	2
16	Floor base unit	1
17	Swivel castor	4
18	Warming grid	1
19	Strut cover infrared ceramic burner	1
20	Infrared ceramic burner cover	1
21	Grid infrared ceramic burner	1
22	Side table (left)	1
23	Bottle opener	1
24	Infrared ceramic burner incl. tray	1
25	Grease drip tray infrared ceramic burner	1
26	Grease drain plate	1
27	Mounting grease drip tray	1
28	Grease drip tray	1
29	Side panel base cabinet (left)	1
30	Spice and sauce holder	1
31	Reinforcement lower cabinet	2
32	Door	1
33	Stainless-steel burner	2
34	Main control knob	3
35	Battery compartment	1
36	Control knob (regulator)	3
37	Smoke box	1
38	Side table hinge infrared ceramic burner (rear)	1
39	Side table hinge infrared ceramic burner (front)	1
40	Side table hinge (rear)	1
41	Side table hinge (front)	1
42	Rear panel base cabinet (small)	1
43	Bottom panel gas bottle	1
44	Pressure regulator and hose	1
45	Tools	1

FASTENERS

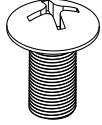
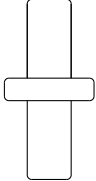
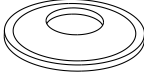
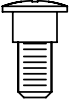
A	B	C	D	E
<p>x 9</p>  <p>5/32-32</p>	<p>x 18</p>  <p>1/4-20</p>	<p>x 1</p> 	<p>x 4</p> 	<p>x 2</p> 

ASSEMBLING THE GAS GRILL



Danger of injury

WARNING: Make sure your gas grill is properly installed, assembled and cared for. Failure to follow these instructions may result in serious bodily injury and/or property damage. If you have any questions concerning assembly or operation, consult our customer service.

The gas grill has some sharp edges. Please wear safety gloves when assembling the unit to avoid cuts.

Before starting with the assembly, remove all packaging material and protective film from the component parts.

After assembly, check all components and screw connections. Make sure that all cables are properly attached and that the burners are firmly attached to the nozzles.

If not, loosen the safety clip on the respective burner head and reposition it.

1

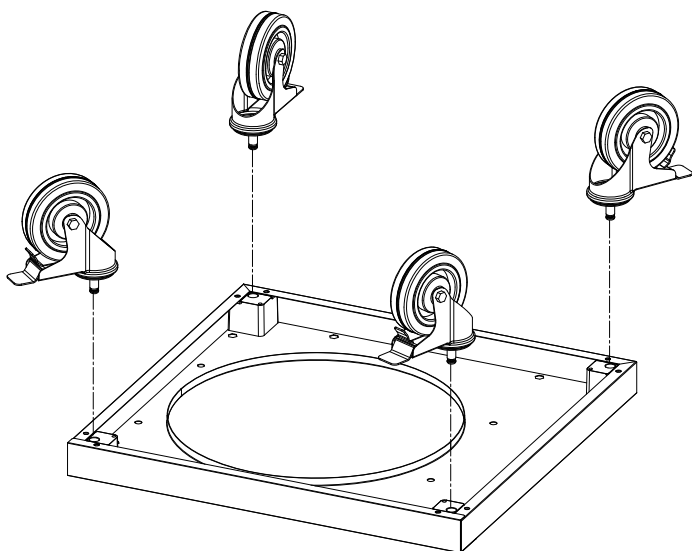

2

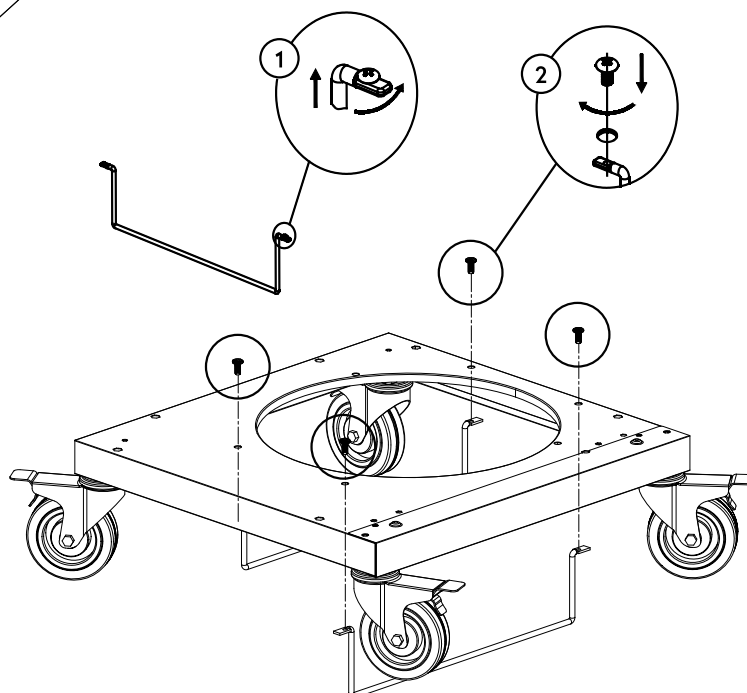

3

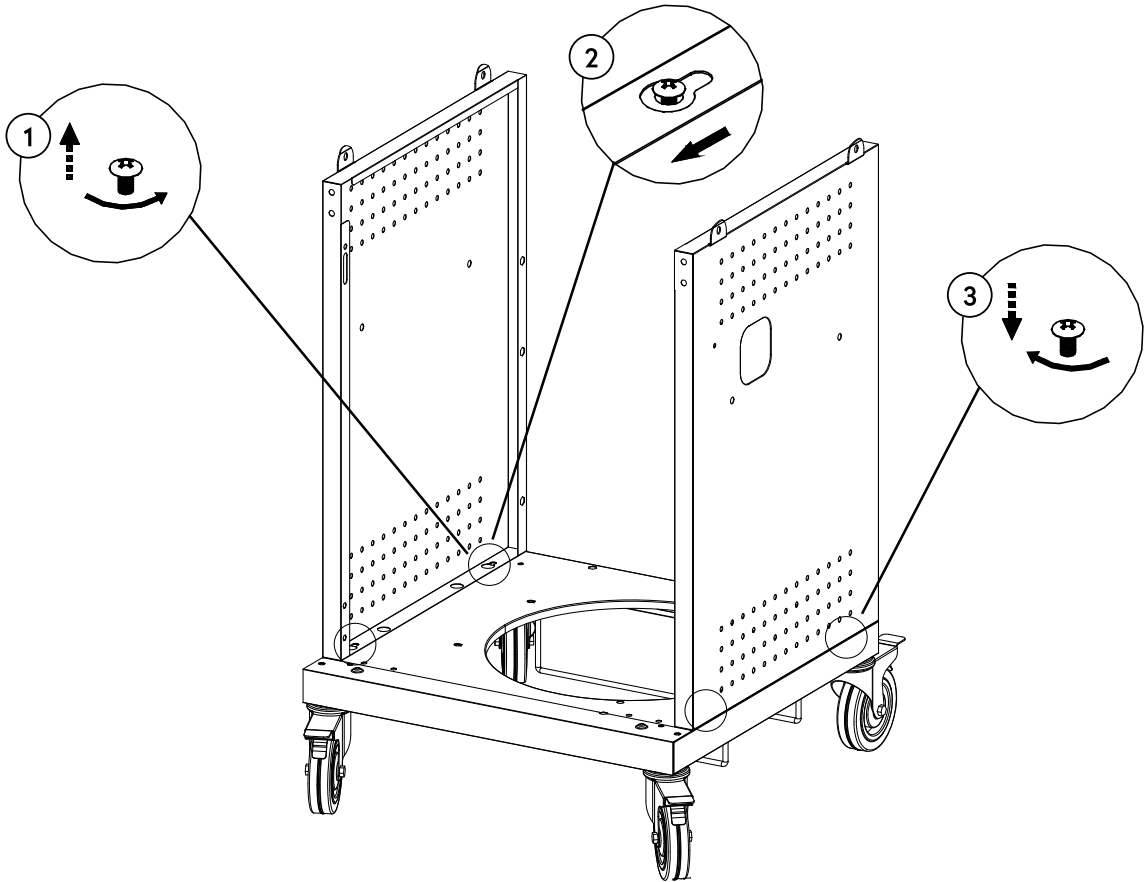

4

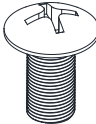
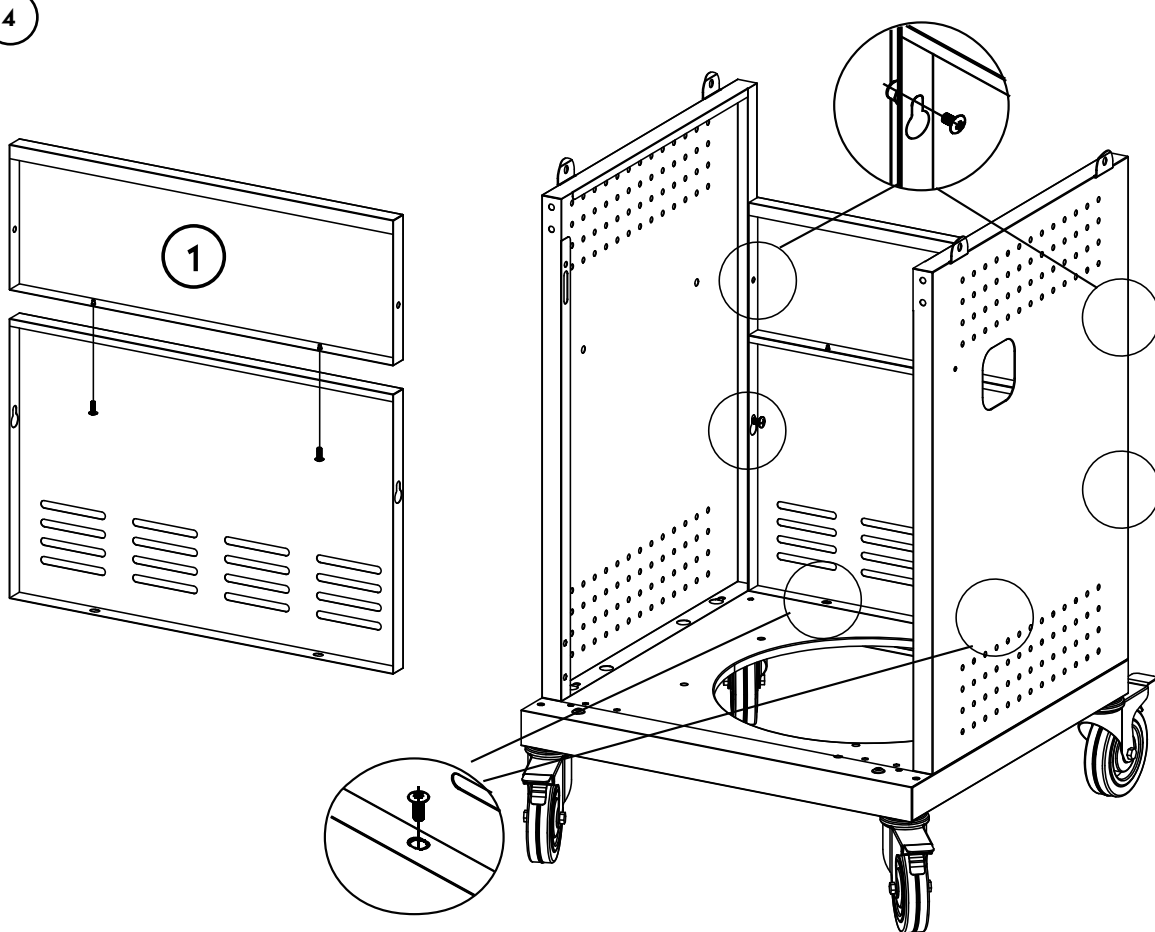

6 x B

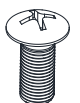

2 x A

5

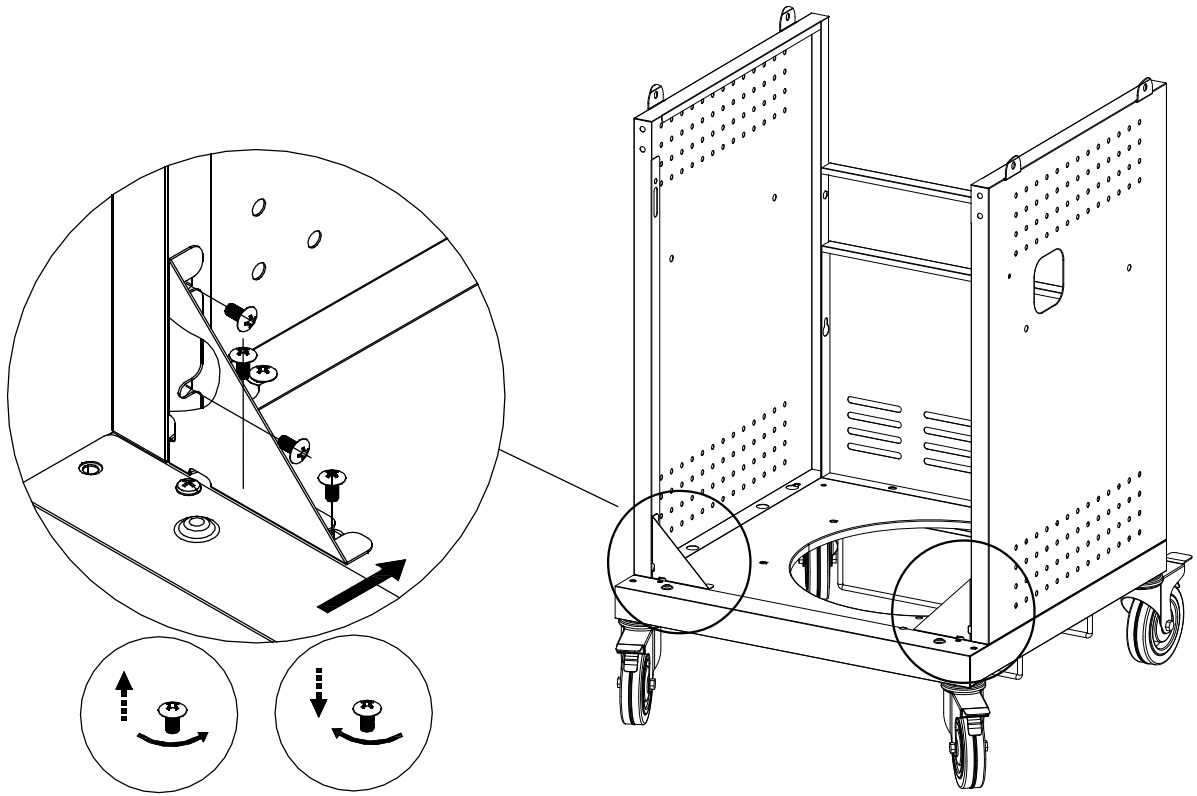

6

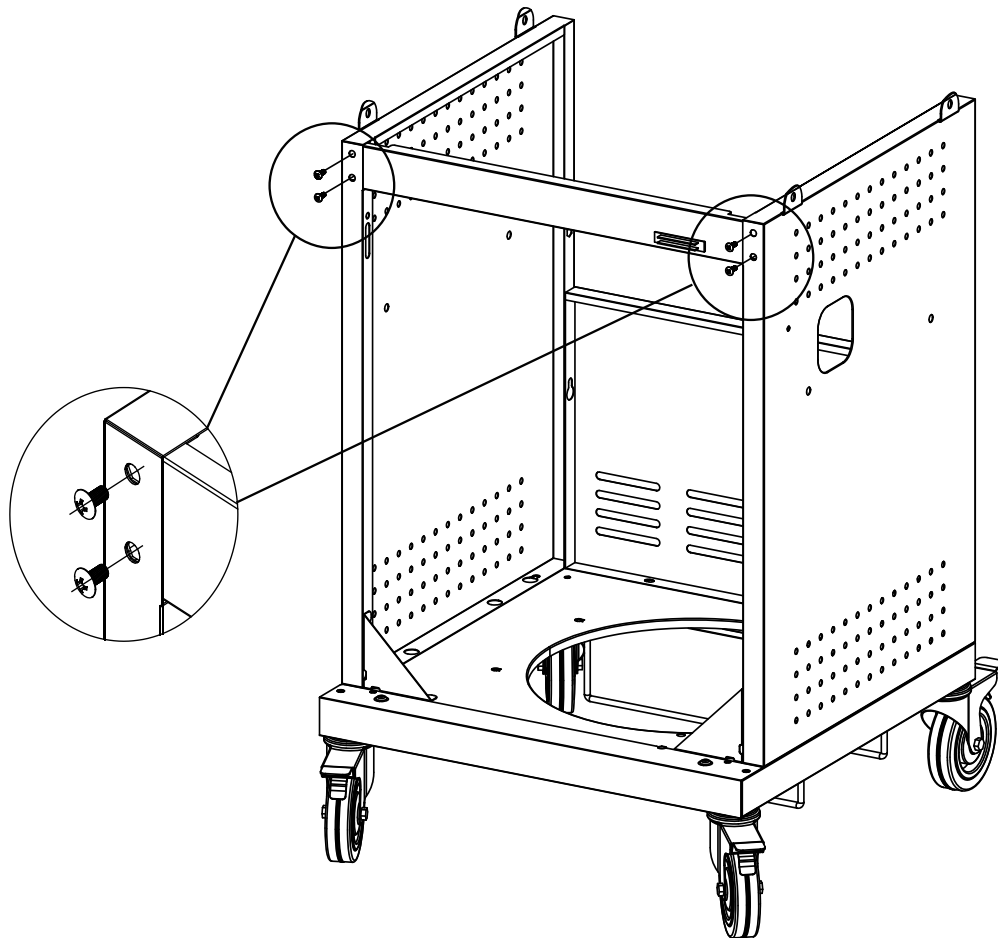

7

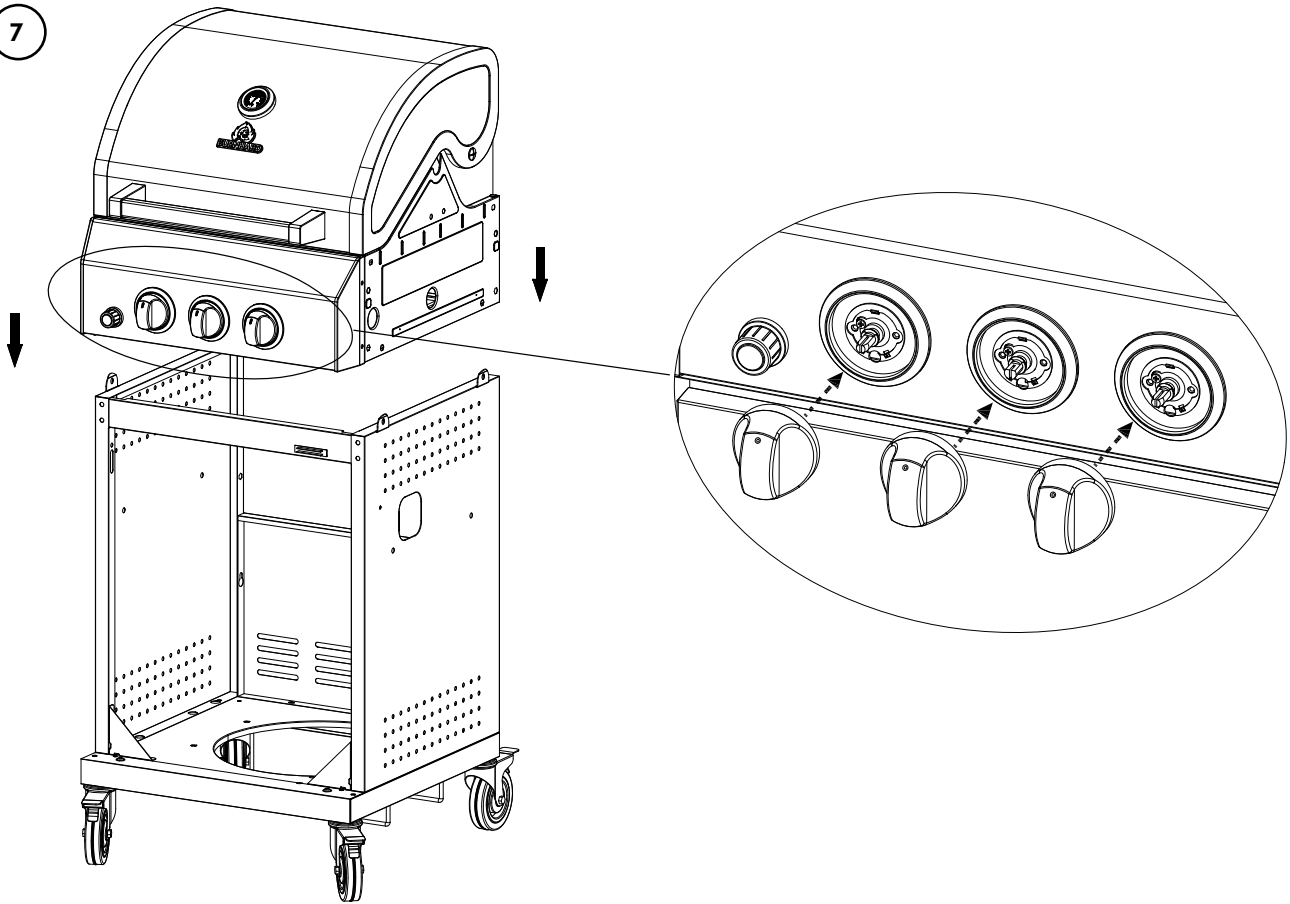

8

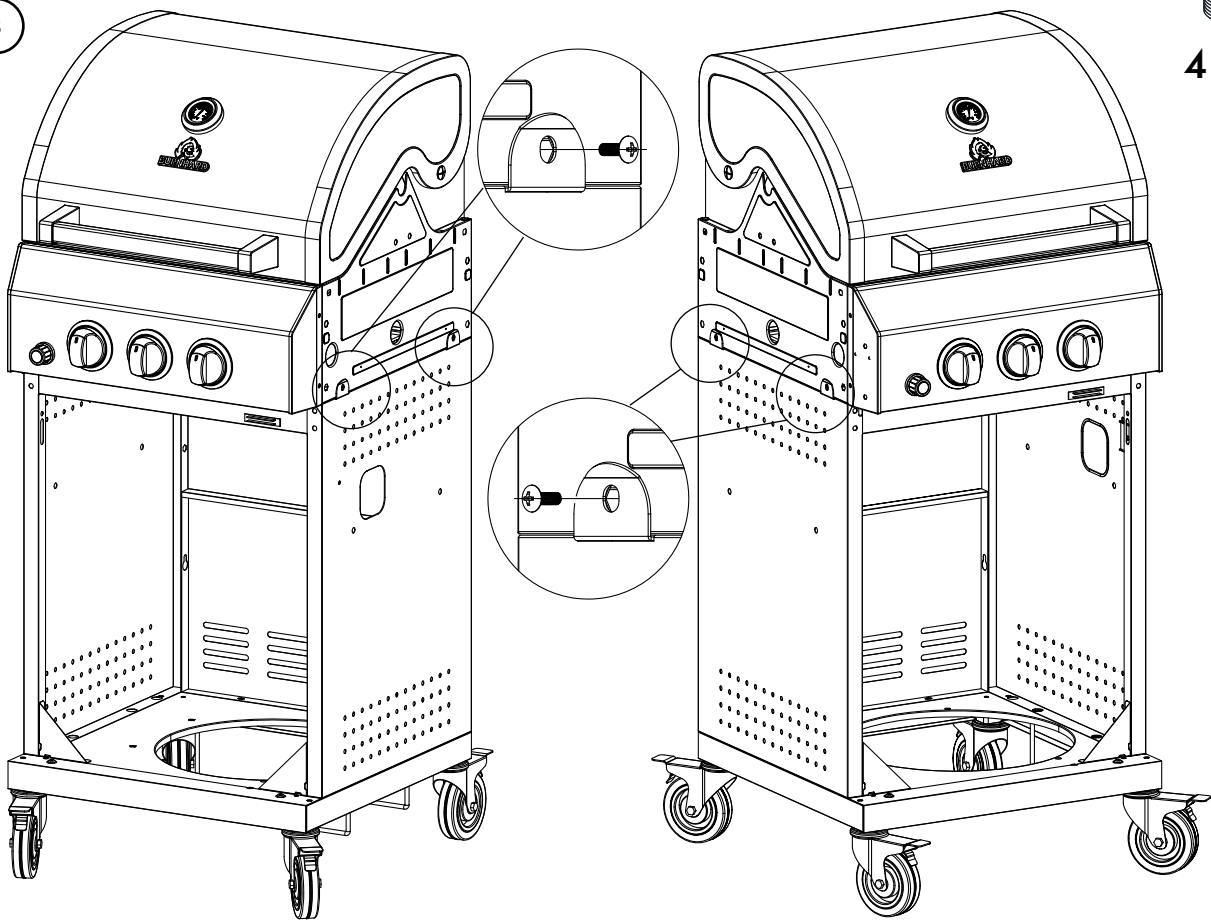

9

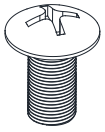

8 x B



4 x D

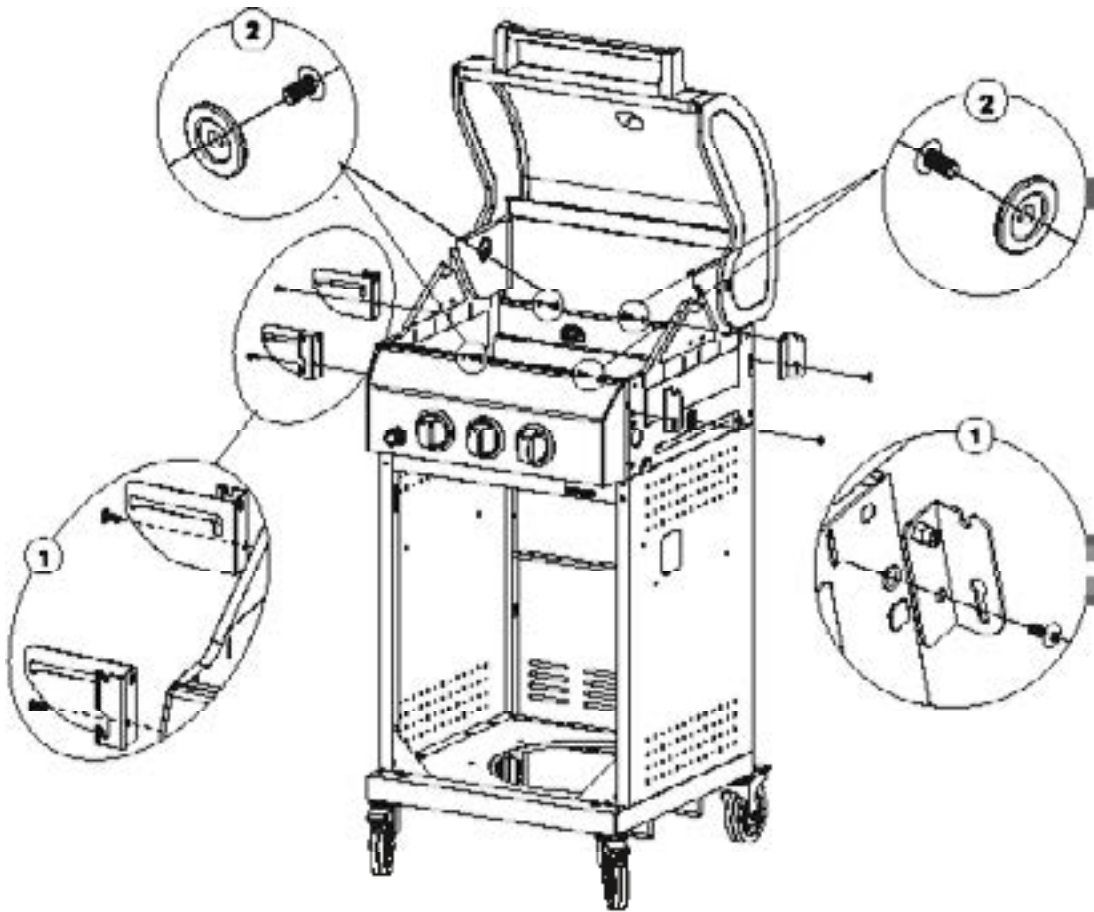

10



2 x E

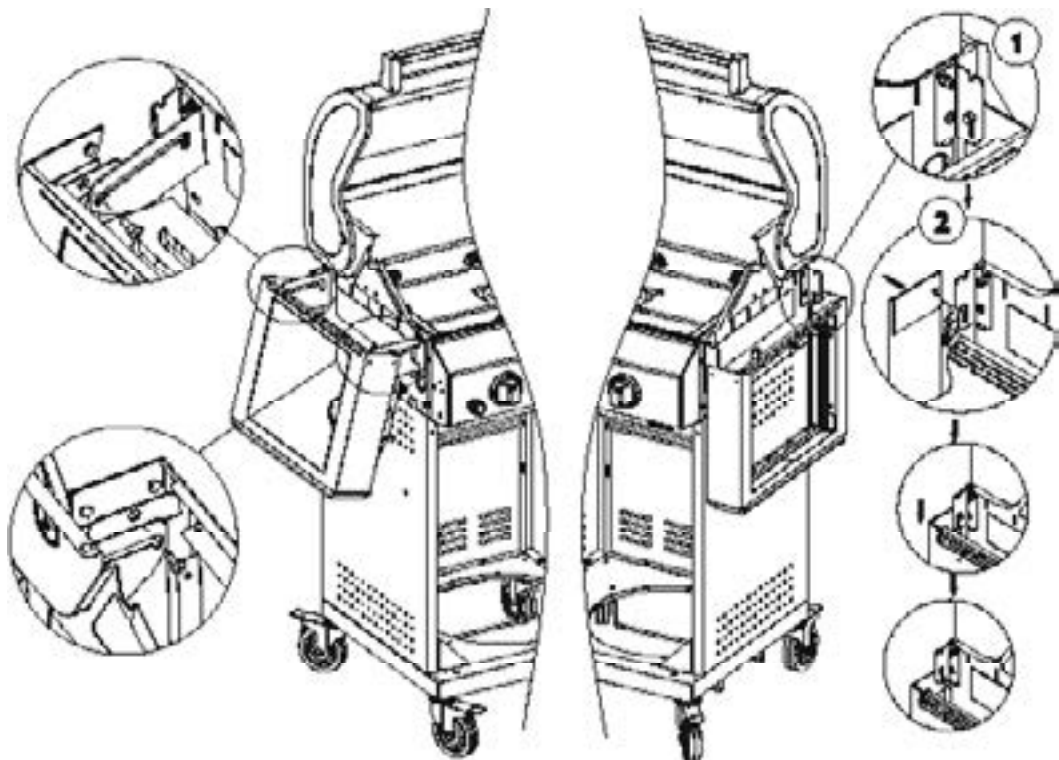

11

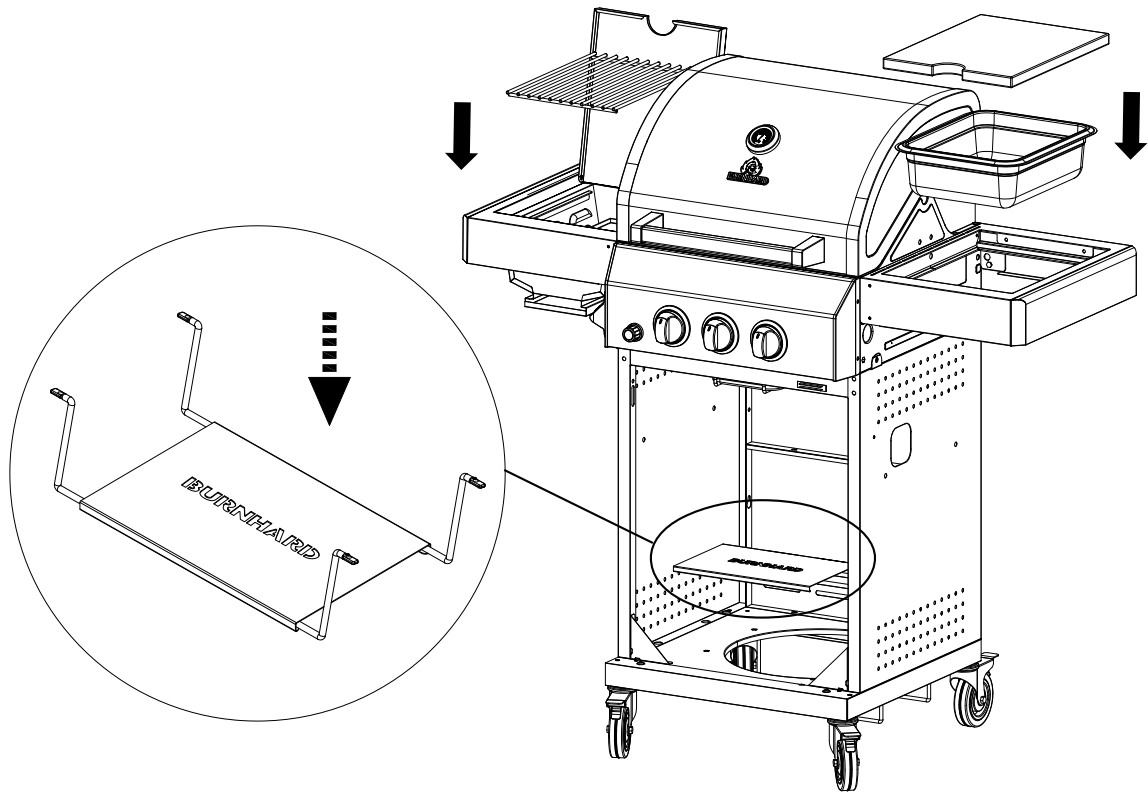

12

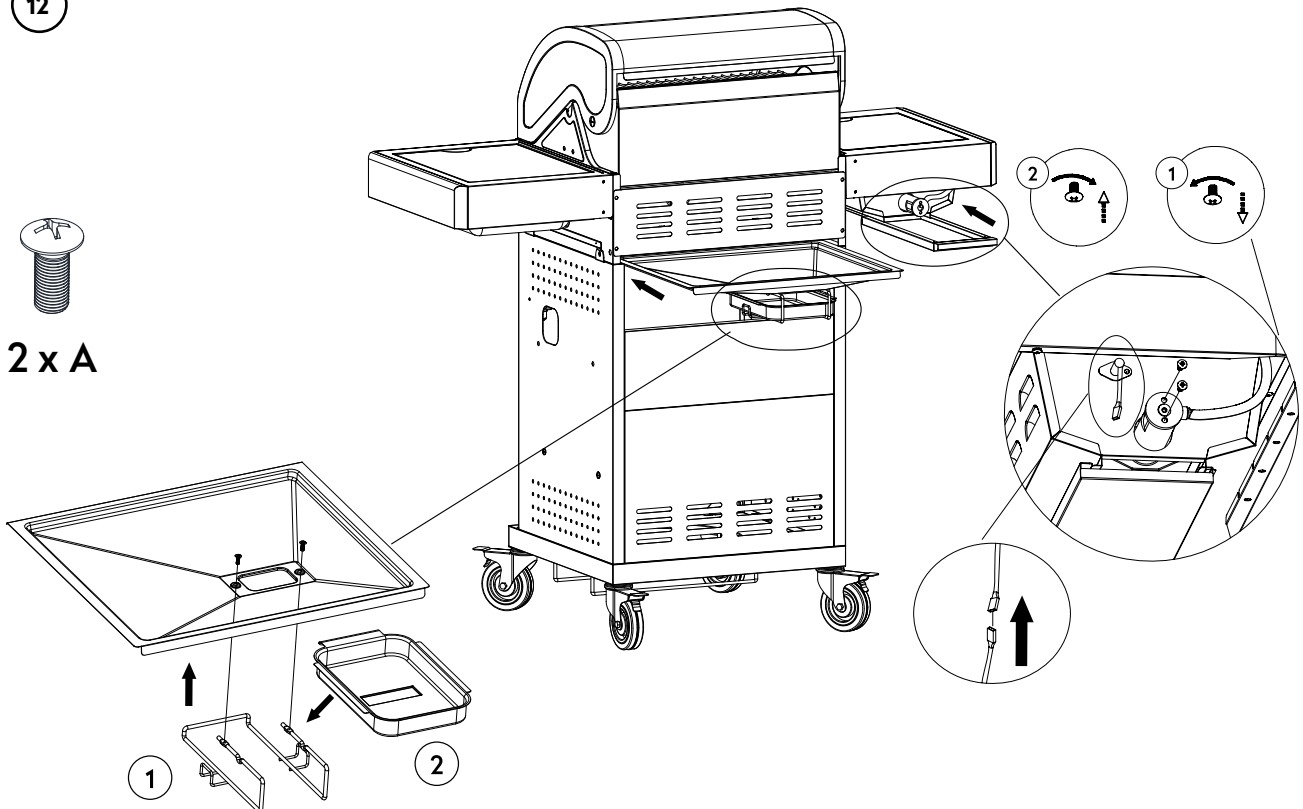

2 x A

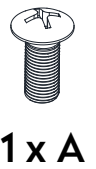
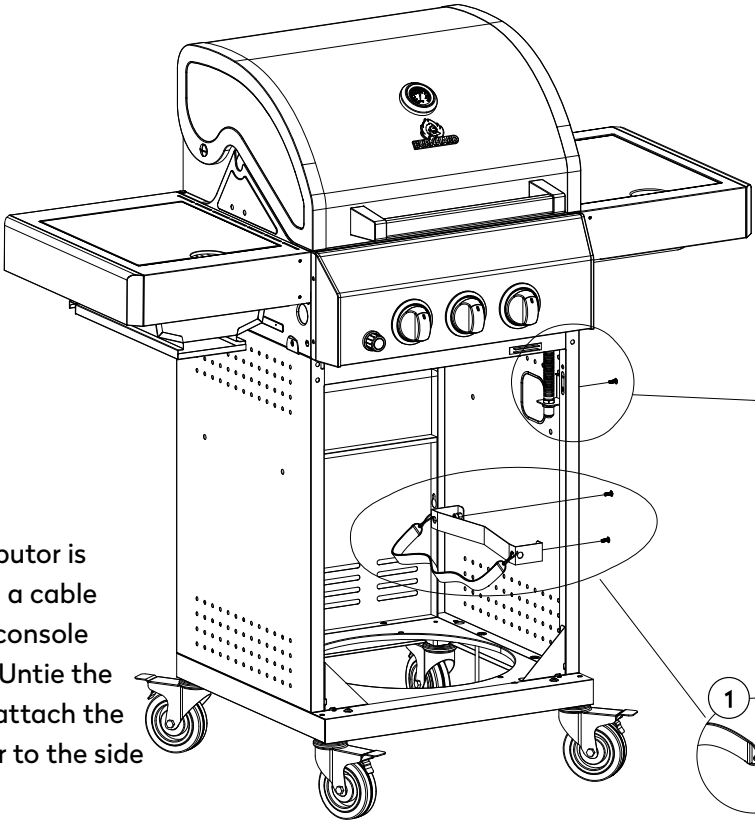

13

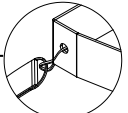
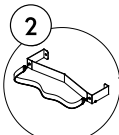
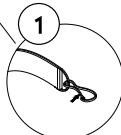
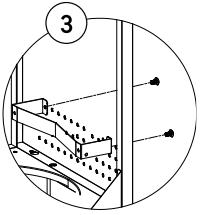
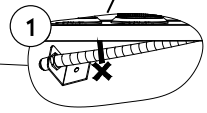
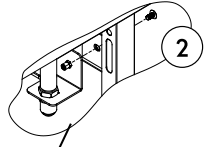

1 x A



The gas distributor is attached with a cable tie below the console for transport. Untie the cable tie and attach the gas distributor to the side panel.

14

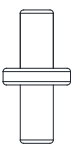
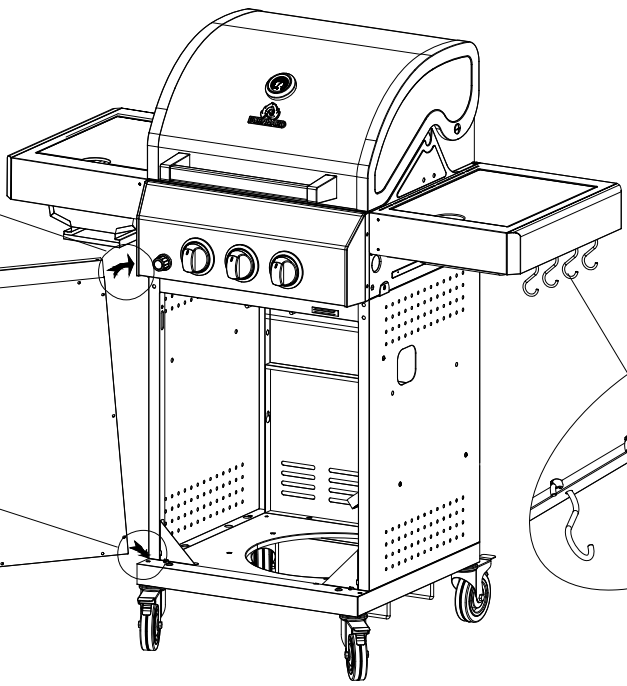
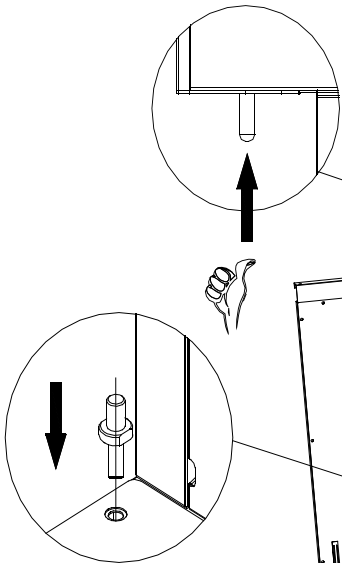

1 x C

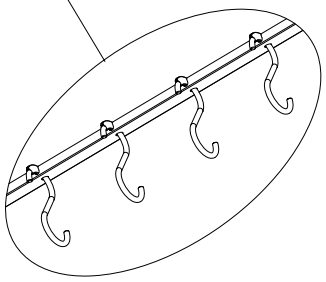

15

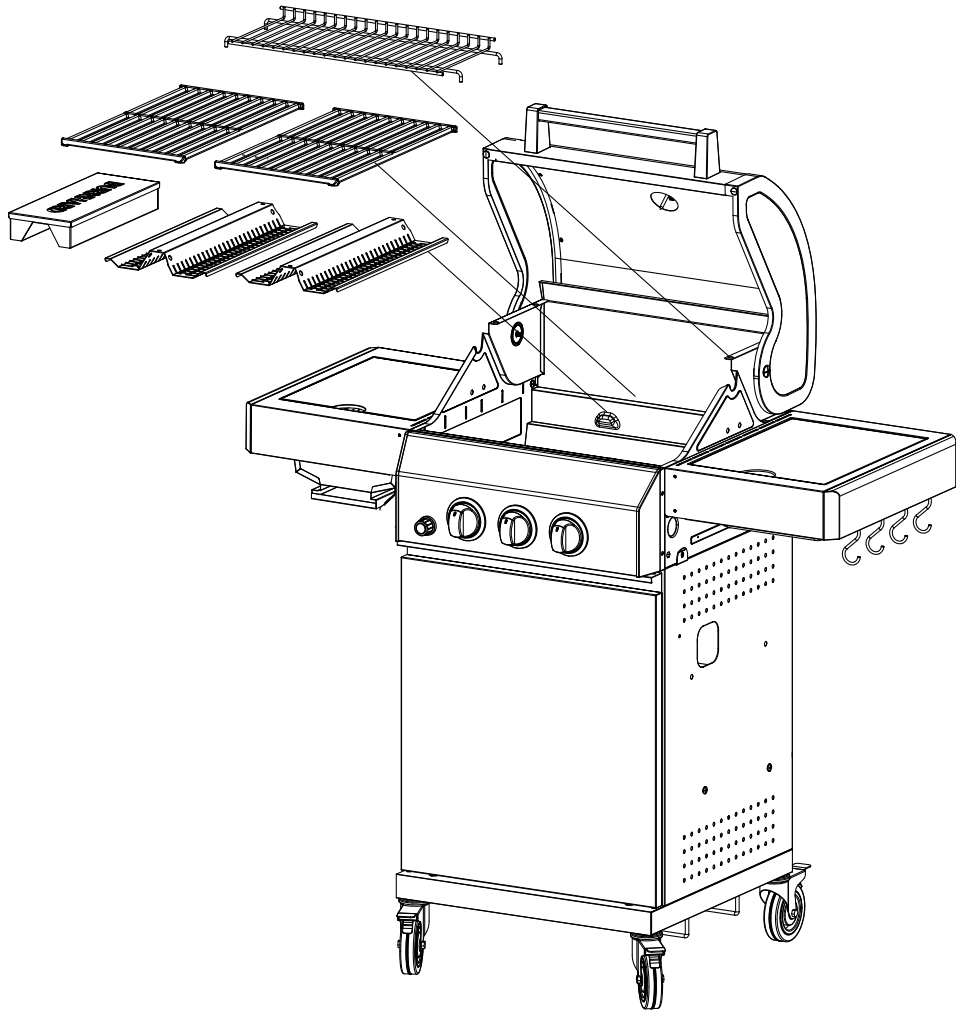

16

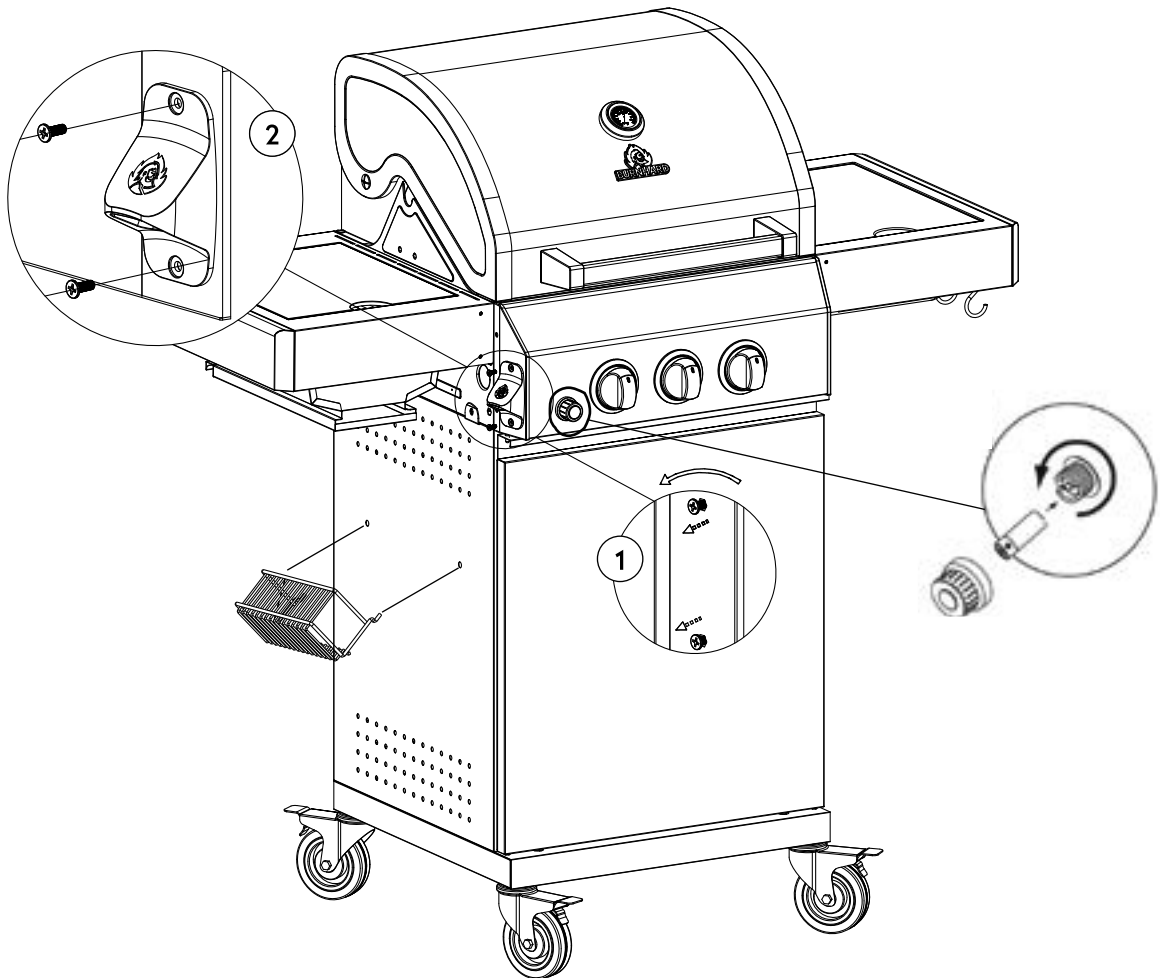



WARNING: The grill radiates heat. Never place the grill next to glass windows, walls, plants, etc. The grill must be placed at a minimum distance from objects of any kind:

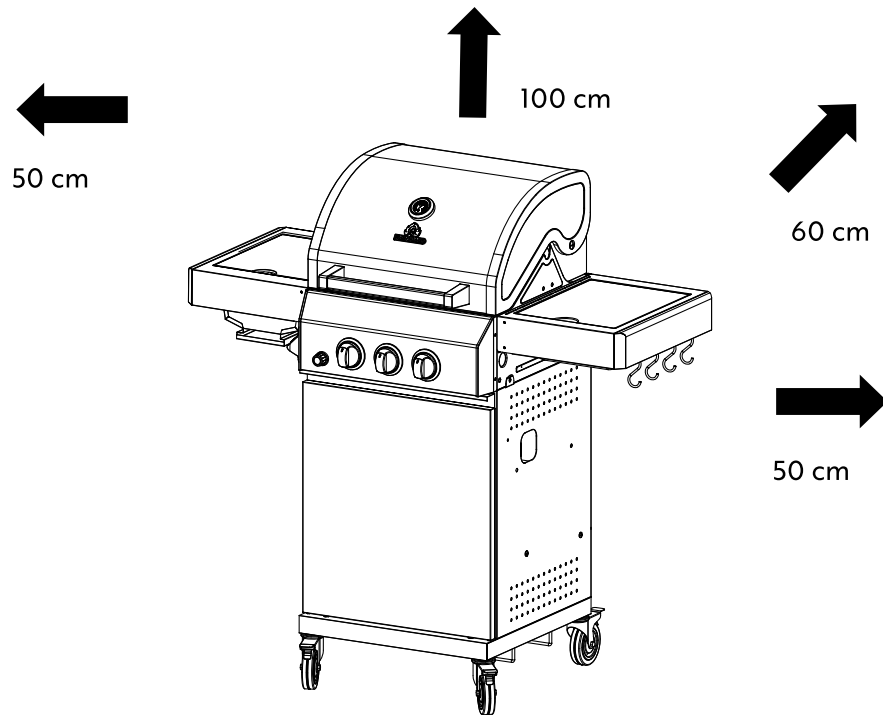

Back: 60 cm
Sides: 50 cm
Top: 100 cm

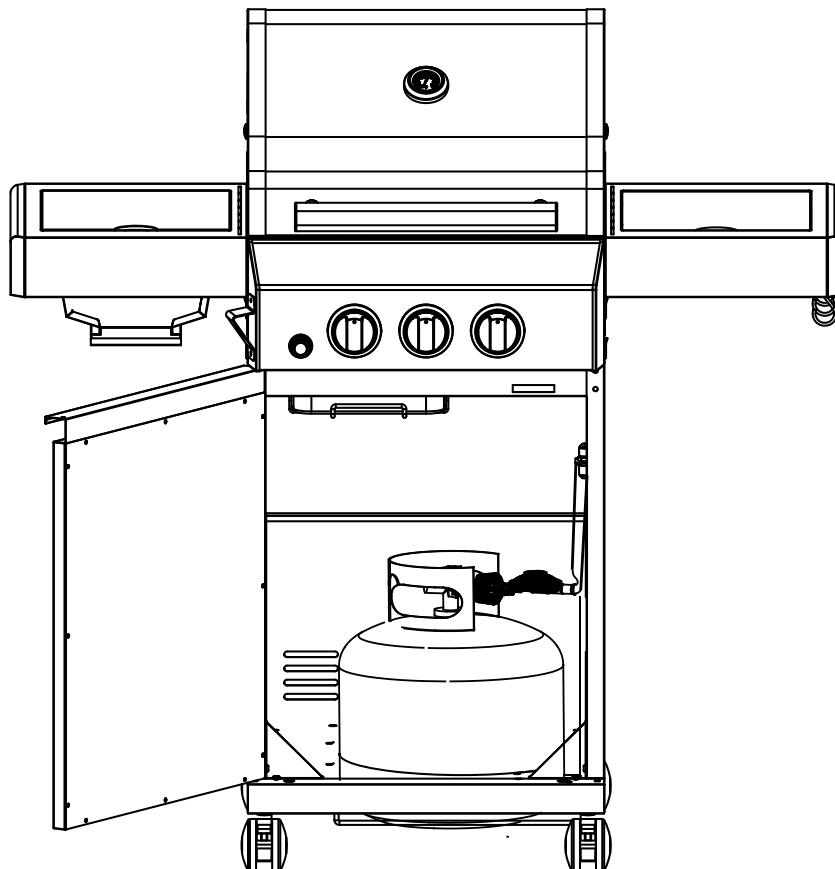

CONNECTING THE GAS CYLINDER



Fire and explosion hazard

WARNING: Never connect new or not completely empty gas cylinders if there are ignition sources in the immediate vicinity. Do not smoke.

The following parts are included. They comply with the applicable standard of the country in which the gas grill is supplied:

- Gas hose (pre-assembled): CE-approved hose line of sufficient length (maximum 1.5 m) that allows kink-free installation.
- Pressure regulator (pre-assembled on the gas hose): Permanently adjusted and CE-approved pressure regulator in accordance with DIN EN 16129, max. 1.5 kg/h, operating pressure 50 mbar, suitable for the gas cylinder used.

1. Unscrew the protective cap from the screw connection on the gas grill. Screw the cap nut at the end of the hose onto the screw connection on the gas grill. Tighten the cap nut with a wrench.
2. Place the gas cylinder in the trolley.
3. Screw the hose cap nut onto the pressure regulator and tighten with a wrench.
4. Screw the cap nut on the pressure regulator onto the screw connection on the gas cylinder. Tighten the cap nut by hand. Don't use tools to avoid damaging the seal.

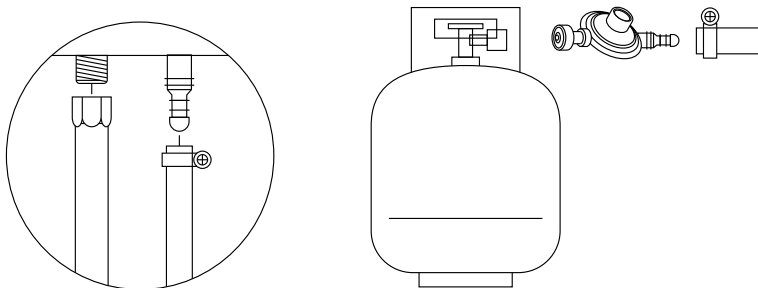

PERMITTED GAS CYLINDER SIZES

Gas cylinder sizes that may be operated and stored in the grill base:

5 kg (height 420 mm, diameter 200 mm)

8 kg (height 505 mm, diameter 229 mm)

11 kg (height 600 mm, diameter 300 mm)

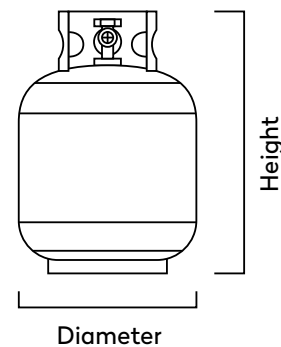

Fire and explosion hazard due to damage to the gas hose

WARNING: When placing the gas hose, ensure that the following requirements are met:

- The gas hose does not touch any hot surfaces.
- The gas hose does not run along sharp edges and corners.
- Hot grease or other liquids cannot drop onto the gas hose.
- The gas hose is not twisted or kinked at any point.

LEAK TEST

- Use a commercially available leak detection spray or paint brush and soapy water to check all connections (mixing ratio of soap to water: 1:3).

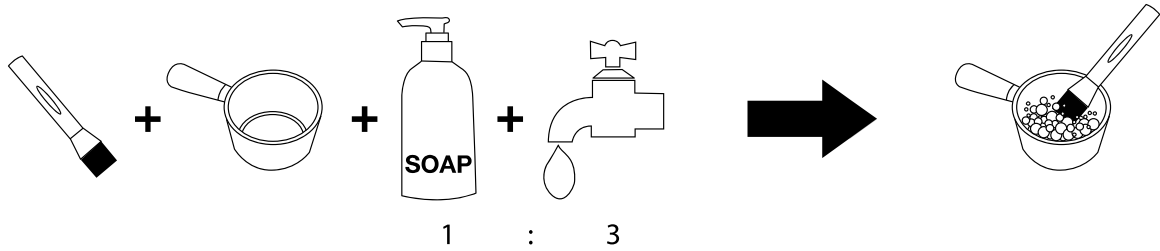

- Open the gas cylinder valve. Small bubbles will appear where there are leaks.

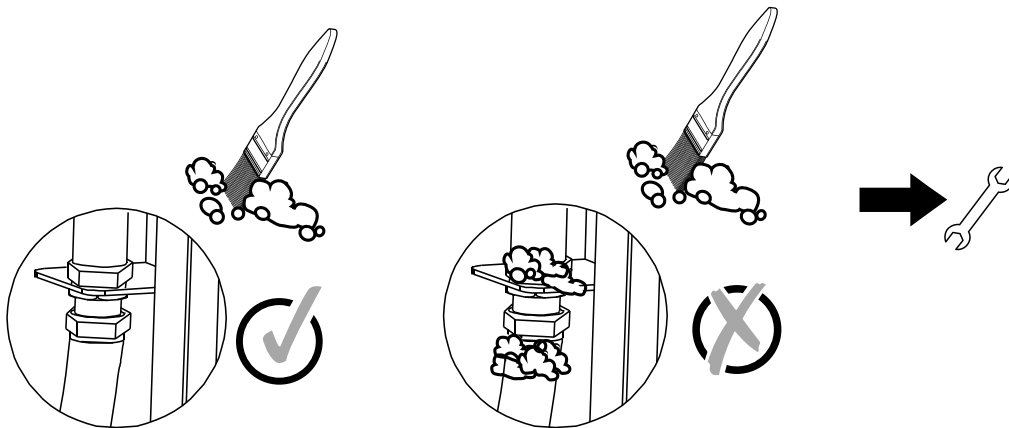

- Close the valve again.
- Tighten the nuts on both sides by hand again and repeat the leak test. If you still notice bubbles, close the gas valve and consult a specialist dealer.

Repeat the leak test every time you change the gas cylinder.

ENERGY SAVING TIPS

1. Turn the grill off as soon as you are done grilling.
2. Preheat the grill with the lid closed for only 10-15 minutes (except for the first use).
3. You do not need to preheat the grill longer than specified.



WARNING: Check the gas connections for breakages, wear, or tear before use. Should you notice any of these, do not use the grill until the issue has been resolved.

When replacing or unscrewing the gas cylinder, make sure there are no fire sources such as candles, electrical appliances, or cigarettes within reach. Always check to ensure the cylinder is properly closed.

OPERATING THE GAS GRILL

WARNING: Never switch the grill on with the lid closed.

Before you use the gas grill for the first time, you should definitely first wipe the surface of the lid and the outer parts of the combustion chamber with a damp cloth. This will prevent any residues from the production process from burning in.

WARNING: Check that all burners are correctly positioned in the respective nozzles and that all cables below are accessible before using the gas grill. If this is not the case, loosen the clamp springs, remove the burners, and reposition them on the nozzles. Then retighten the clamping spring.

Before grilling for the first time, allow it to burn for 40 minutes without food. Preservation residues are removed in this way. If there is a slight odour, you don't need to worry. This is harmless. Make sure the grill is adequately ventilated. Scrub the grids with a stainless-steel brush afterwards.

The colour inside the gas grill can change slightly. This is a natural process.

IGNITING THE GAS GRILL

1. Open the grill lid.
2. Turn all control knobs clockwise to the "OFF" position.
3. Connect the pressure regulator to the gas cylinder.
4. Open the gas cylinder valve and use a leak detection spray or soapy water to check for leaks between the gas pressure regulator and the gas cylinder.
5. You can light the burners independently.
6. Press and hold down one of the knobs while turning it anticlockwise to the "HI" position. You will hear a "click" sound and the burner should ignite. If it does not ignite right away, repeat this step 3 to 4 times.
7. **WARNING:** If the burner does not ignite after repeated attempts, turn the knob clockwise to the "OFF" position and close the gas cylinder valve. Wait 5 minutes and then start again from step 4.
8. Once you have ignited the burner, repeat steps 6 and 7 with the other knob to ignite the second burner.
9. Adjust the heat by turning the control knob to the desired setting between the highest ("HI") and lowest ("LO") levels.

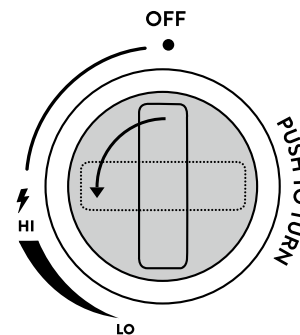

USING THE INFRARED CERAMIC BURNER IN THE SIDE TABLE



WARNING: The lid of the infrared ceramic burner installed in the side table must always be open before ignition or during operation. If you do not use the grill for a long time, remove the battery. It may leak and irreparably damage the ignition.

WARNING: Never fold down the side table while the infrared ceramic burner is in operation. Make sure that the burner and firebox have cooled down completely before folding down the side table.

The burner heats a ceramic stone perforated with small holes. The energy is stored by the stone, which allows particularly high temperatures to be reached. This way, you can easily make your steaks and burger patties super crisp without affecting the core temperature.

1. Unscrew the battery compartment on the control panel and insert an AA battery (pay attention to the correct polarity).
2. Open the lid of the infrared ceramic burner in the side table.
3. Press and turn the large knob in the middle counterclockwise until you hear the gas entering.
4. Count to 5 and light the burner by holding the electric igniter (button) on the battery holder for a few seconds.
5. If the burner does not ignite, proceed exactly as with the stainless-steel burners.

The ceramic burner is continuously variable, just like a standard stainless-steel burner.

WARNING: The ignition electrode is operated with a battery. There is a risk of fire and explosion if batteries are handled incorrectly.

- Leaking battery acid can cause skin burns and damage to components.
- Observe the manufacturer's safety instructions for handling batteries.
- Do not throw batteries into fire, short-circuit them or destroy them in any other way.
- Remove the battery if you are not going to use the device for a long time.
- Only handle damaged batteries with protective gloves.

SWITCHING OFF THE GAS GRILL

1. Turn the knob clockwise to the "OFF" position.
2. Close the gas cylinder valve and turn all knobs clockwise to the "OFF" position.

CLEANING THE GAS GRILL



Fire and explosion hazard

- Do not use any flammable cleaning agents.
- Remove the gas cylinder before cleaning the gas grill.
- Wait until the grill has cooled down completely before cleaning.
- Clean the grill after each use.
- Remove the grease trap and dispose the grease in an environmentally friendly manner.
- Wipe the stainless-steel surfaces and grids using a wet cloth or clean it with hot water. If necessary, use a mild detergent. Rinse with water and allow the gas grill to dry completely before the next use. Next, polish the stainless-steel surfaces with a stainless-steel cleaning agent.
- Use a brush to remove food particles from the burners.
- If in exceptional cases one of the nozzles is blocked, use a jet needle to clean it.
- If in exceptional cases the Venturi tube (gas-mixing pipe) is blocked, use a needle or pipe cleaner to clean it.

Recommended equipment: stainless steel barbecue brush, soft cotton cloth (not microfiber), sponge, wooden scraper, bucket, suitable barbecue cleaner (for the interior), suitable stainless steel cleaner (for the exterior), mild dishwashing detergent, possibly a scouring pad/steel wool, protective goggles, single-use gloves, splash guard for your upper body (apron)

CLEANING AFTER EVERY USE

To prepare for your next barbecue session, you should let the grill burn out after every use (without food). This allows residue and grease on the grids to burn. Afterwards, you can simply brush them off.

1. Close the lid and set all stainless steel burners (not the infrared ceramic burner in the side table) to "HI".
2. Let the grill burn out for 15–30 minutes until there is no more smoke coming out of the grill.
3. Close the gas cylinder valve and turn off all burners.
4. Slowly open the grill (be cautious of escaping heat) and scrub the grids with the stainless steel barbecue brush until clean.

NOTE: Brass brushes are very soft and therefore not suitable for cast iron and stainless steel grids. They can also stain which can lead to rust.

Once your grill has fully cooled down, empty and clean the grease drain plate and drip tray. If you covered your tray with aluminium foil, replace it.

CLEANING THE INTERIOR

To clean the inside of your grill, start by removing the grids, take out the grease drain plate, and remove coarse dirt. Empty and clean the grease drip tray.

1. To clear coarse dirt out of the flame distributors, take them out and let them soak in warm water with a little dishwashing detergent for 1 hour. Then clean them with a sponge, warm water, and dishwashing detergent. You can also clean them in the dishwasher. Dry thoroughly afterwards.
2. Release the safety clamps (by pressing down) from the burner heads and remove the stainless steel burners from your grill.

3. Insert the grease drain plate (without the drip tray) into the grill again and place the empty bucket beneath the opening.
4. Rinse out the interior of your grill with water (e.g. with a watering can). **WARNING:** Make sure that no water gets into the gas nozzles.
5. Apply a suitable cleaning agent for grill interiors (barbecue cleaner or dishwashing detergent) to the inside of the grill and let it soak for the amount of time indicated by the manufacturer. **WARNING:** Do not exceed the recommended application time of the cleaning agent used. Otherwise the material can become discoloured or damaged.
6. Remove stubborn stains in the interior of your grill with a sponge or a wooden scraper.
7. Thoroughly rinse you grill with water, let it dry completely, and carefully clean the burners and nozzle outlets with a dry cotton cloth (or a brush).
8. Insert the parts back into the grill.

CLEANING THE EXTERIOR

1. Clean the exterior of your grill with a soft cotton cloth, warm water, and mild detergent. **WARNING:** Do not use a microfiber cloth to clean the stainless steel surfaces – this would scratch the material.
2. Thoroughly dry the surfaces with a soft cotton cloth and apply a suitable stainless steel cleaner as needed. **WARNING:** Take note of the application time indicated by the manufacturer of the stainless steel cleaner and do not exceed it.
3. Wipe off any residue of the stainless steel cleaner with a clean, soft cotton cloth. **WARNING:** Make sure that you have completely removed all residue of the stainless steel cleaner before you use your grill again. Otherwise it can stain and discolour or damage the material.

MAINTENANCE OF THE CAST IRON GRIDS

The grids are enameled. This layer protects against rust and prevents food from sticking to the grids. Despite this protective layer, the grids can absorb and release grease and moisture. It is therefore advisable to let the grids burn-in as well.

BURNING-IN THE CAST-IRON GRIDS

Cast iron grids must be given some time to burn in to protect the metal from rust and enable a non-stick surface. The burn-in process of cast iron can be performed in 3 simple steps:

1. Clean the cast iron grids with warm soapy water, rinse well, and wipe dry.
2. Grease the grids completely. Use an unrefined oil or fat with a low smoke point. **WARNING:** Never use olive oil or whey products - these become bitter when burned, have an unpleasant smell and cause heavy smoke.
3. Place the grids on the grill and set the stainless steel burners to "HI". Let them burn-in for 45 minutes at the highest temperature with the lid closed. This burns the grease permanently onto the iron thus creating a protective patina.

MAINTENANCE OF THE STAINLESS STEEL GRIDS

Stainless steel grids do not need to be burned in. You can clean the durable grids with warm water, mild detergent and a sponge by hand or in the dishwasher.

Stainless steel can slightly discolour when exposed to high temperatures. This is a natural process and has no effect on the quality or your grilling result.

MAINTENANCE AND CLEANING OF THE INFRARED -CERAMIC BURNER

The ceramic brick cannot be cleaned. Fat and meat juices dripping onto the ceramic brick will combust. Hence, staining of the brick and baked-on residues are normal and do not affect the burner's performance.



WARNING: Under no circumstances shall the ceramic brick be cleaned with water and/or detergents. If something falls through the protective grid and is not burnt completely, adjust the burner to the highest heat possible and let all residues combust for 10-15 minutes.

Make sure to only cook non-marinated grillables on the ceramic brick. Salty and acidic marinades or pepper may damage the ceramic brick when dripping down during cooking over long periods of time.

REGULAR MAINTENANCE

After grilling, you should prepare the grill for the next use. Let the grill burn freely at maximum heat with the lid closed to burn up any residues on the grids and then brush them off.

Follow the procedure below to do this:

1. Remove all food from the grill and set the grill to maximum heat with the lid closed. Let it burn freely for 20-40 minutes until no more smoke comes out of the grill. For stubborn stains, turn the cast iron grids over so that the used side faces down.
2. Close the gas cylinder valve (rotate to OFF) and subsequently turn the control knobs to the OFF position.
3. Next, use a long-handled stainless steel brush to clean the grill. Make sure to wear grilling gloves or potholders since the grill is still very hot.
4. Pour some lard, linseed oil or sunflower oil on a cloth and rub it on the cast-iron grids to prevent rust and renew the patina for the next use. Stainless steel grids do not require further maintenance.

It is recommended that you clean the dirty spots on the edge of the cast iron grids separately every 2-3 times you use the grill. Here, you should first let the grill burn freely and then clean it using a wire brush. To clean the dirty spots on the edges, remove the grids from the grill and scrub them carefully under warm water (no detergent) using a wire sponge (pot sponge). Afterwards, use a cloth to dry them thoroughly, allow to dry completely, apply some oil, and place them back into the grill.

Stainless steel grids can easily be cleaned with detergent, sponge and warm water or in the dishwasher.

If the grids show signs of flash rust, scrub the rusty surfaces with steel wool until you have completely removed all the rust. Next, wash the grids with warm water, rub dry thoroughly with a cloth, allow to dry completely and repeat the burning-in process.

If possible, store the cast iron grids in a dry place during winter.

General cleaning of the grill should be done every 3-4 months. You should let the grease residues burn, empty the grease trap, and clean the grease tray and grids every time you use the grill.

WARNING: The enclosed wooden chopping board is a natural product and will expand due to moisture and weather conditions and/or mildew might set in. Therefore, store the chopping board in a dry and warm place after each barbecue and take it outside only when grilling.

Clean the board with a damp sponge after use. For heavier soiling, use some mild detergent. Never put the board in the dishwasher. Do not leave it in the dishwasher or water for a long time. Treat the cutting board regularly with a suitable maintenance oil.

TROUBLESHOOTING

Problem	Possible cause	Solution
Burner does not ignite	Gas cylinder is empty	Connect new gas cylinder
	Faulty pressure regulator	Have the pressure regulator checked by a specialist dealer
	Impurities in the burner	Clean the burner
	Impurities in the ignition system or gas hose	Clean the ignition and gas hose
Small flame or deflagration in the burner (crackling or hissing noise)	Impurities in the burner	Clean the ignition and burner
	No ignition spark	Replace the piezo ignition
	Nozzle defective (if the burners still do not ignite despite the previous recommendations)	Please contact our customer service to obtain a replacement
Infrared ceramic burner does not ignite or simply goes out	Gas bottle is empty or it is too windy	Connect a new gas cylinder or move the grill to a more sheltered area

REPLACING THE STAINLESS-STEEL BURNERS

If one or more burners are defective, replace the affected burners as follows:

1. Remove the clamping spring. Pull the burner back slightly and carefully lift out the corresponding burner.
2. Clean or replace the defective burner(s). Put the burners back in and secure them with the clamping spring.

STORING THE GAS GRILL

- Store the gas grill in a dry room protected from frost. Close the grill hood and cover the unit to protect it from dirt and damage.
- A cover protects your grill from the weather such as rain, hail, snow, wind and frost all year round.
- Always close the gas cylinder valve and keep it out of the reach of children.
- Bring the cast iron into the house/flat during the winter season to prevent rust.
- Also observe the instructions for storage in the safety instructions section.

CUSTOMER SERVICE

In principle, our products have a legal warranty duty of 2 years. Further claims can only be processed in conjunction with a proof of purchase. Wearing parts exclude any warranty claims, when usual abrasion has occurred. The durability is determined by the respective handling and use of the products and is thus variable.

For questions concerning handling and functionality of our products, please contact our customer service:

Free hotline for Germany/Austria only: 0800 270 70 27

From other EU countries: +49 211 - 749 55 10*

*Different costs may apply.

E-Mail: service@burnhard.de

Internet: www.burnhard.de

DISPOSAL/RECYCLING



Our products are manufactured to high quality standards and are designed for a long service life. Regular maintenance and care will help to extend service life. If the appliance is defective and can no longer be repaired, it must not be disposed of in the normal household waste.

The product and its packaging must be disposed of in accordance with local regulations. Contact your local waste disposal company if necessary.

DECLARATION OF CONFORMITY

The Springlane GmbH hereby declares that this product conforms to the basic CE requirements as of the day of publication. The full declaration of conformity can be found at www.burnhard.de.