

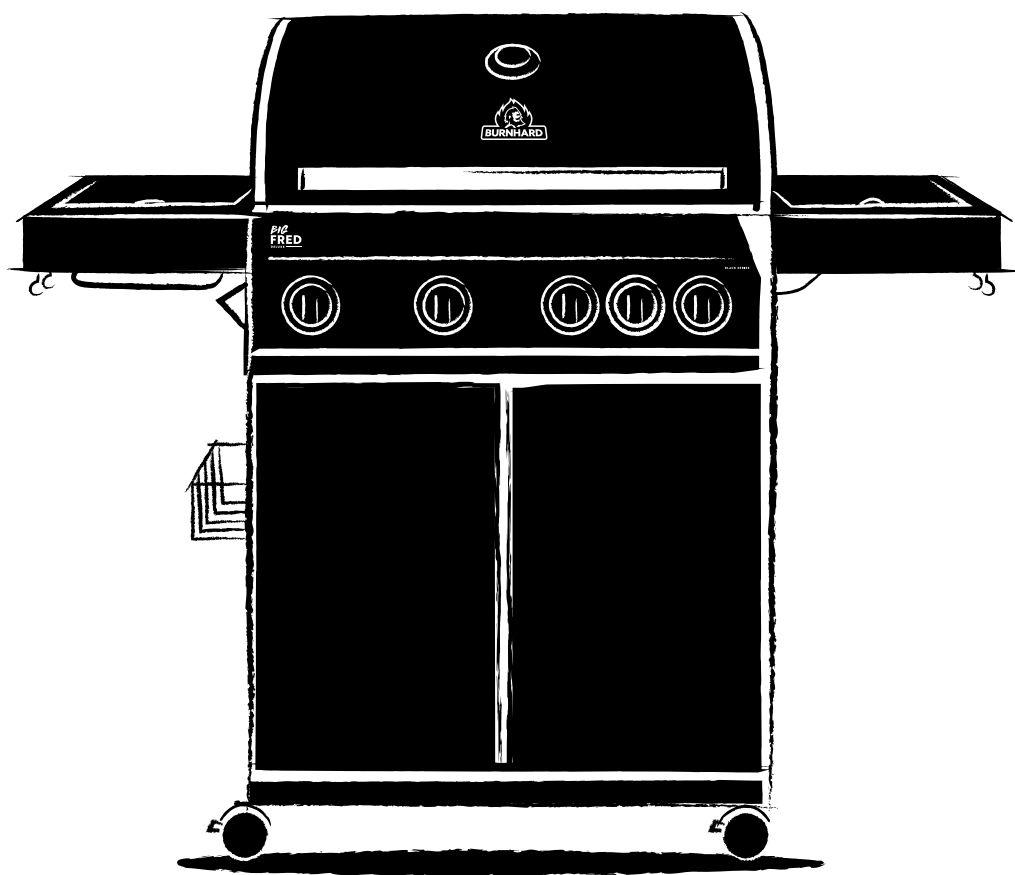

BURNHARD



4-BURNER GASGRILL

BIG FRED

DELUXE

4-BURNER GAS GRILL BIG FRED DELUXE

BLACK SERIES

CONTENT

4-BURNER GAS GRILL BIG FRED DELUXE BLACK SERIES

Technical specifications	32
Safety instructions	32
Equipment delivered/Description of components	36
Assembling the gas grill	39
Connecting the gas cylinder	50
Operating the gas grill	52
Cleaning the gas grill	53
Regular maintenance	56
Troubleshooting	57
Storing the gas grill	57
Customer Service	58
Disposal/Recycling	58
Declaration of conformity	58

TECHNICAL SPECIFICATIONS

Power:	Total 17 kW – 3 main burners with 3.5 kW, 1 infrared ceramic burner with 3.5 kW, 1 side cooking hob with 3 kW
Dimensions (W/H/D):	140 x 118 x 55 cm
Weight:	ca. 48 kg
Nominal heat load (Hs) Burner:	17 kW
Connected load Burner:	1236 g/h
Operating pressure:	50 mbar
Type of gas:	butane (G30) and propane (G31)
Appliance class:	I3B/P(50)
Includes:	3 stainless steel burners, 1 infrared ceramic burner, 1 side cooking hob, 3 grill grids, warming grid, food container with wooden cutting board, lid thermometer, piezo ignition
Accessories:	gas hose and pressure regulator (50 mbar), spice and sauce holder, 4 hooks, bottle opener, smoker box, cover

Subject to changes and errors in features, technology, colours, and design.

EXPLANATION OF SYMBOLS



This symbol warns of hazards that can damage the device or cause injury.

SAFETY INSTRUCTIONS

Read the instructions before using the appliance.

INTENDED USE

This gas grill may only be used outdoors and in well-ventilated areas. Never use the gas grill inside a building, garage, or any other enclosed area.

General hazards



- Danger to children or persons with limited ability to operate equipment. This appliance is not intended for use by children or persons with limited ability to operate equipment. The appliance may only be used by persons who are able to operate equipment safely.
- **WARNING:** Accessible parts may be very hot. Keep young children away.
- Do not modify the appliance in any way. Any changes to the appliance can lead to accidents and invalidate the warranty.

UNPACKING THE DEVICE

Danger to children. Danger to life through suffocation/ingestion. Keep the packaging material away from children. Dispose of it immediately. Keep small parts out of their reach.

CONNECTING THE GAS SYSTEM



Fire and explosion hazard

- This gas grill may only be operated with a suitable pressure regulator. The enclosed pressure regulator is set correctly at the factory for liquid gas operation.
- The gas hose may have to be exchanged if required by the relevant national regulations.
- Make sure that there is no ignition source, open fire or similar in the vicinity when you connect or replace the gas cylinder.
- Ask for advice when buying or renting the gas cylinder from a specialist retailer.
- The appliance must be connected as described in this manual. Make sure that the gas hose is not kinked or chafed.
- Perform the leak test procedure described in this manual (found under CONNECTING THE GAS CYLINDER) before using the grill. Perform the leak test every time you replace the gas cylinder.

GENERAL SAFETY INSTRUCTIONS



Fire and explosion hazard

- Use outdoors only.
- Do not move the appliance during use.
- This appliance must be kept away from flammable materials during use.
- When changing the gas cylinder, care must be taken that there are no combustible materials, children, or pets in the vicinity.
- Improper assembly of the grill may be dangerous. Follow the assembly instructions exactly.
- This gas grill is not intended for commercial use.
- Do not use charcoal, briquettes, or lava stones in the gas grill. The appliance may not be operated with natural gas.
- Never smoke when handling the gas unit. Do not place the gas cylinder near an open fire.
- Make sure that the gas grill is protected from the wind.
- Keep the grill away from moisture, splashing water etc. as well as electrical cables.
- Keep the grill a minimum distance of 1.5 m from all flammable materials and 7.5 m from all flammable liquids.
- Set up the gas grill on a level, stable, and fireproof surface.
- Protect the gas cylinder from strong sunlight.
- Check the hose and regulator for tears and damage before each use. Do not use the gas grill if the regulator, gas hose, or cylinder is defective or leaking.
- Check the burners for dirt before each use and remove it before starting the grill.
- Do not ignite the gas flame with an open flame. Use only the piezo ignition of the respective burner to ignite it.
- To avoid gas escaping accidentally, the valve on the gas cylinder should only be open when the gas grill is in operation. Close the cylinder valve immediately when you switch off the gas grill.
- Make sure that the ventilation holes on the housing are not covered under any circumstances.
- The surfaces of the gas grill become very hot during operation. Warn bystanders and keep children and pets away.
- Never bend over an open grill when lighting or using it.
- Always wear protective gloves when the gas grill is in use and the temperature of the hot components exceeds the ambient temperature by 50 °C.
- Never leave the gas grill unattended during use.
- Close the gas cylinder valve immediately in the event of a malfunction or gas leak.
- Before changing the position of the gas grill, the gas unit must be switched off, the gas cylinder valve closed, and the gas cylinder unscrewed from the gas hose to protect the pressure regulator and the hose line.
- Turn off the gas supply at the gas cylinder after use.
- The lid must always be open when igniting the burner.

MAINTAINING THE GAS GRILL



Fire and explosion hazard

- Repairs and maintenance on the gas unit may only be carried out by authorised specialist personnel. Do not make changes to the gas grill or the pressure regulator.
- Replace the pressure regulator and the hose after 10 years at the latest, even if there is no visible external damage. Make sure that the pressure regulator is approved for the gas used and is set to the correct operating pressure (see TECHNICAL SPECIFICATIONS). A new hose may not be longer than 1.5 m.

MEASURES IN CASE OF GAS ODOUR

- Close the gas supply, extinguish all open flames and open the lid.
- If the smell of gas is still present, keep away from the appliance and inform your gas supplier or the fire brigade.

FIRE-FIGHTING MEASURES

- Get people around you to safety! If possible, close the valve on the gas cylinder. Cool the gas cylinder with water. Pay attention to your safety. Spontaneous, explosive reignition is possible.
- In case of fire, filled pressurized gas containers should be removed from the area threatened by the fire. If this is not possible, the compressed gas containers must be kept from overheating by suitable means, like spraying with water from a protected position.
- If grease fire should break out, try (if possible) to switch off the burners, close the lid until the fire is extinguished.
- **WARNING: Never attempt to extinguish an oil or grease fire with water.** Always use the fire extinguishing agents provided for this purpose: grease fire extinguisher and/or fire blanket. Ask a specialist dealer for specific information on this.
- Keep away from the source of the fire and inform the fire brigade immediately.

FIRST-AID MEASURES

What to do in case of gas inhalation

- Inhaling high gas concentrations can lead to suffocation. Possible symptoms include loss of mobility and unconsciousness. The victim does not realise that he or she is suffocating. If inhaled in low concentrations, the gas can cause dizziness, headaches, nausea, and problems with coordination.
- Move the victim to fresh air. Contact a doctor or rescue service. In case of respiratory arrest, initiate artificial respiration.

What to do in case of severe burns or scalds

- There is an acute risk of hypothermia and shock. Call the emergency services immediately!
- Immediately douse burning clothes with water or smother the flames with a thick blanket.
- Burns: leave clothes on the body.
- In case of scalding: remove clothing immediately.
- Cool the affected area with cold water for at least 15 minutes until the pain subsides.
- Cover the affected area with a sterile Metalline towel. Apply the Metalline-coated side to the injured skin and fix it loosely with a gauze bandage or a triangular cloth.
- Do not use "home remedies" such as ointments, powders, oils, disinfectants, etc.!

Measures for minor burns or scalds

- Burns: remove clothing only if it does not stick to the body.
- In case of scalding: remove clothing immediately.
- Cool the affected area with cold water for at least 15 minutes until the pain subsides.
- Let small burns or scalds that haven't formed blisters heal in the air, do not cover with a patch or bandage.

INSTRUCTIONS FOR TRANSPORT



Fire and explosion hazard

- If possible, do not transport the gas cylinder in vehicles in which the load compartment is not separated from the driver's cab. The driver must be aware of the potential dangers of the cargo and must know what to do in the event of an accident or emergency.
- Transport the gas cylinder upright and secured against falling over and slipping.
- Make sure that the gas cylinder valve is closed tightly.

STORAGE INSTRUCTIONS



Fire and explosion hazard

- Store the gas cylinder out of reach of children.
- Keep the gas bottle away from oxidising gases and other oxidising substances.
- Escaping LPG is heavier than air and sinks to the bottom. Do not store the gas cylinder at home lower than ground level (for example, in the cellar, underground car park, etc.) or in unventilated places where escaping gas could accumulate.
- Protect the gas bottle from direct sunlight and other heat sources. Store the gas bottle at a temperature of less than 50 °C in a well-ventilated, shady place and protected from weather influences.
- Store the gas cylinder upright and secured against falling over.
- Do not store spare / additional or disconnected gas cylinders under or near the gas grill.
- The storage instructions also apply to empty gas cylinders. These still contain a residual amount of LPG.

EQUIPMENT DELIVERED/DESCRIPTION OF COMPONENTS

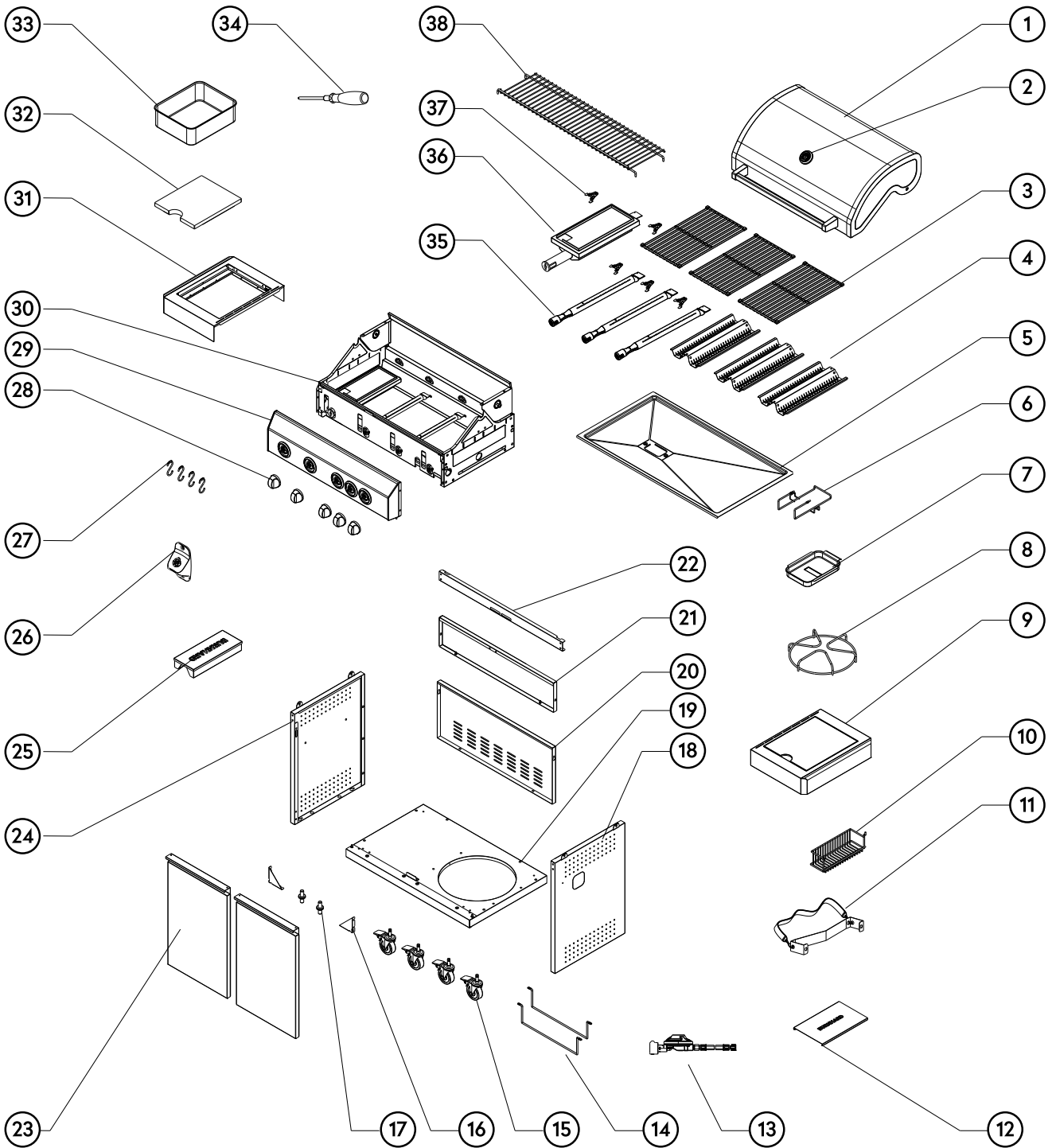

Ref.	Description	Quantity
1	Lid	1
2	Lid thermometer	1
3	Grid (big)	3
4	Flame distributor	3
5	Grease drain plate	1
6	Mounting grease drip tray	1
7	Grease drip tray	1
8	Warmer side hob	1
9	Side table with hob (right)	1
10	Spice and sauce holder	1
11	Gas bottle holder	1
12	Bottom panel gas bottle	1
13	Pressure regulator and hose	1
14	Gas bottle suspension	2
15	Swivel castor	4
16	Reinforcement lower cabinet	2
17	Door spindle	2
18	Side panel base cabinet (left)	1
19	Floor base unit	1
20	Rear panel base cabinet	1
21	Rear panel base cabinet (small)	1
22	Lower cabinet strut	1
23	Door	2
24	Side panel base cabinet (left)	1
25	Smoke box	1
26	Bottle opener	1
27	Accessory hook	4
28	Control knob (regulator)	5
29	Front control panel	1
30	Combustion chamber	1
31	Side table (left)	1
32	Wooden cutting board	1
33	Food Container	1
34	Tools	1
35	Stainless-steel burner	3
36	Infrared ceramic burner	1
37	Clamping spring	4
38	Warming grid	1

FASTENINGS

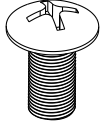
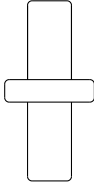
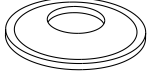
A	B	C	D
<p>x 9</p>  <p>5/32-32</p>	<p>x 18</p>  <p>1/4-20</p>	<p>x 2</p> 	<p>x 4</p> 

ASSEMBLING THE GAS GRILL



Danger of injury

WARNING: Make sure to assemble the grill according to the following instructions. Failure to follow these instructions may result in serious bodily injury or damage to property. Contact our customer service if you have questions about assembling or using the unit.

The gas grill has some sharp edges. Please wear safety gloves when assembling the unit to avoid cuts.

Before assembling the unit, remove all packaging materials and protective wrapping from the various components.

Check all components, screws, and connections after assembly. Make sure that all cables are correctly installed and that the back on the back of the control panel are secure. If they are not, loosen the security clip on the respective burner head and reposition it.

1

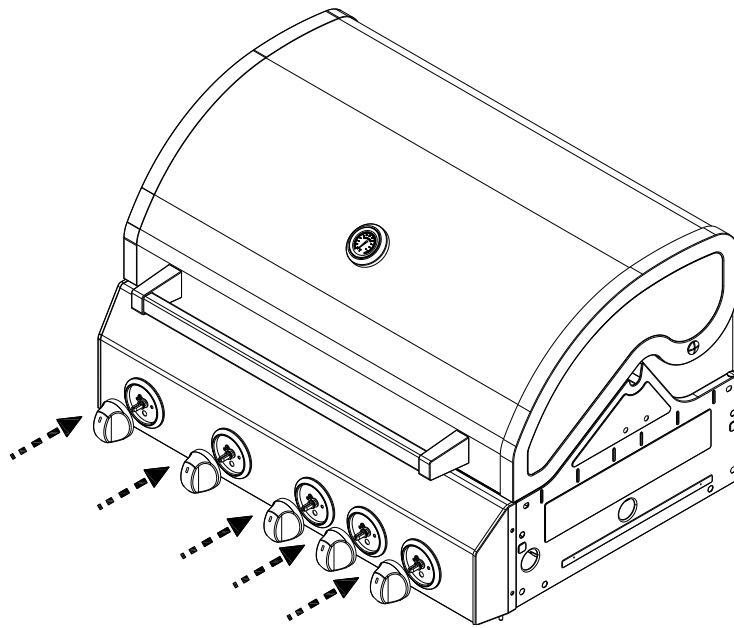

2

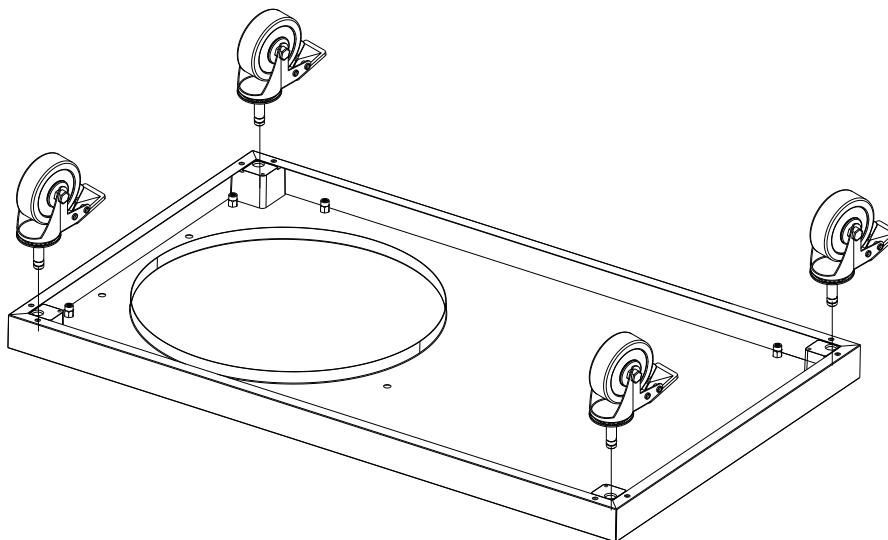

3

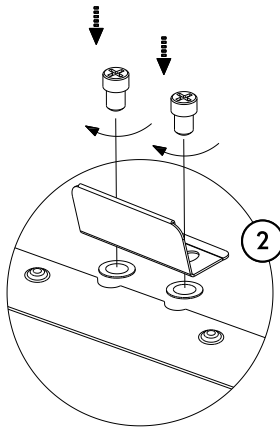
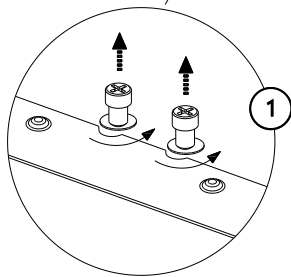
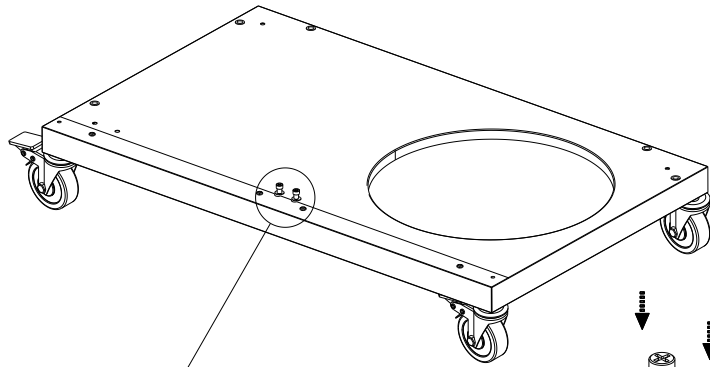

4

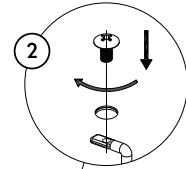
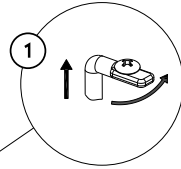
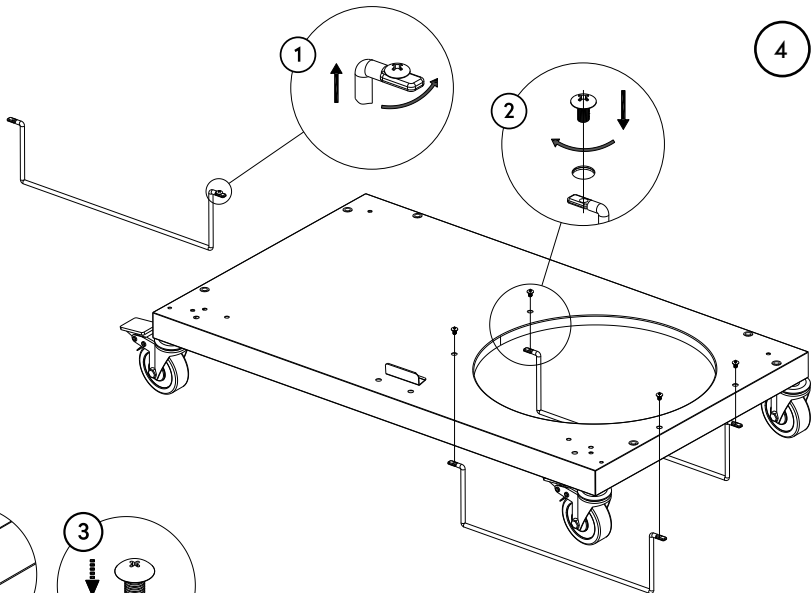

5

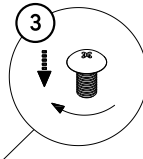
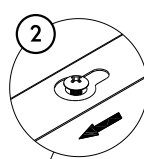
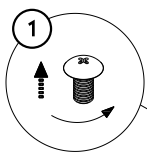
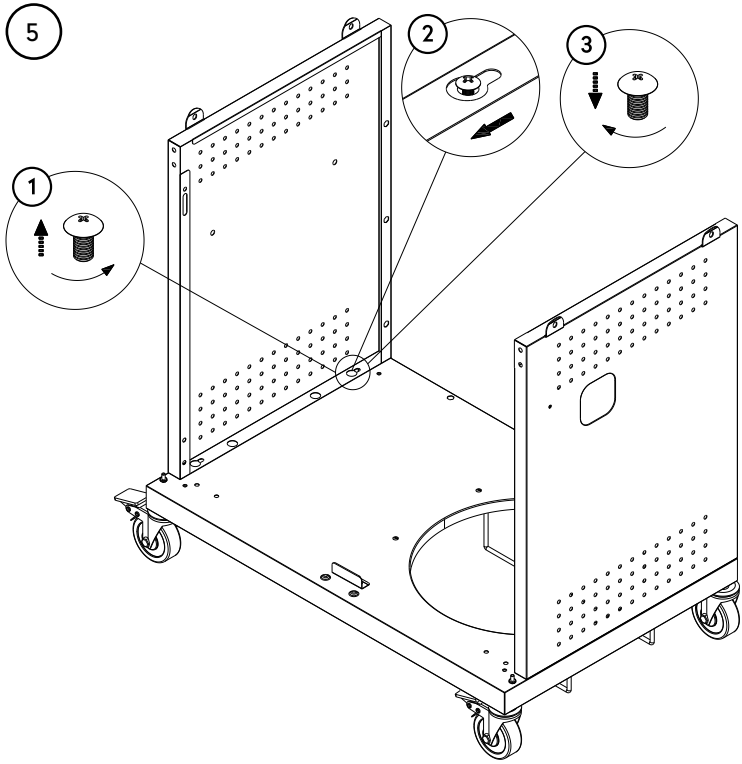

6

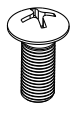

2 x A

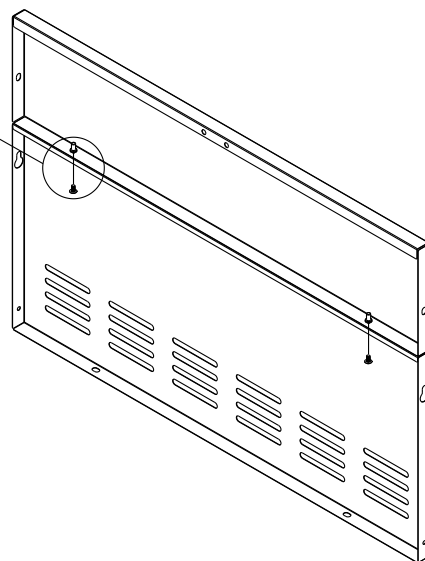
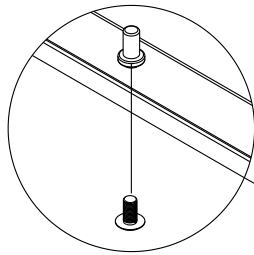

7

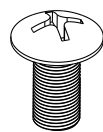
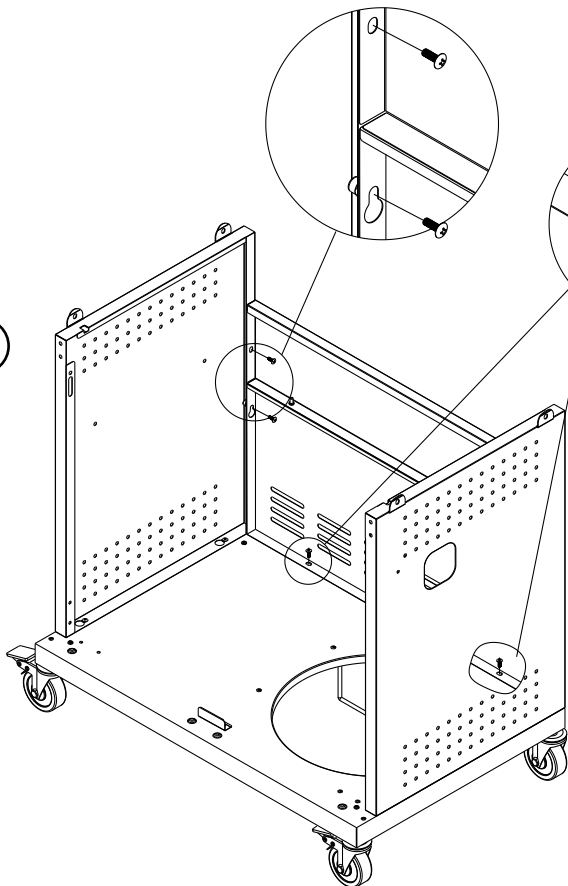

6 x B

8

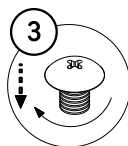
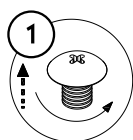
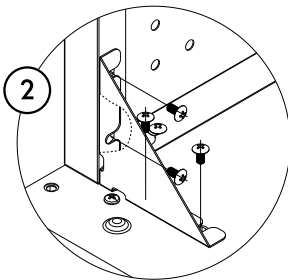
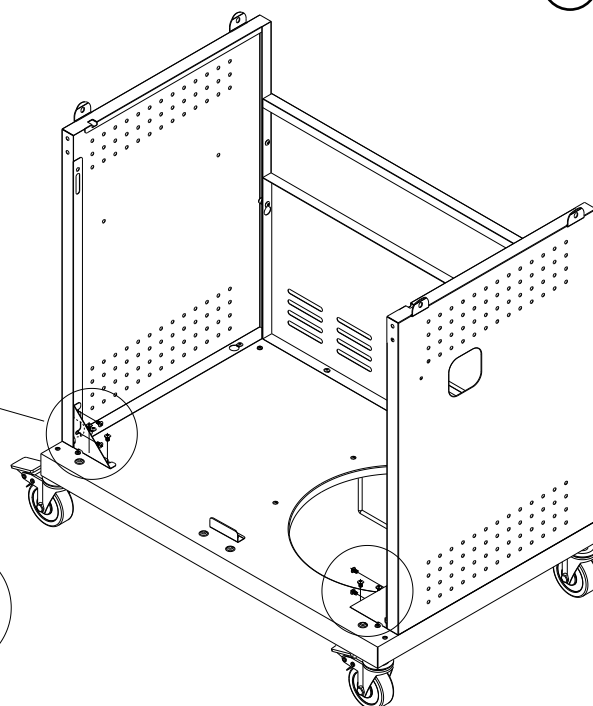

9

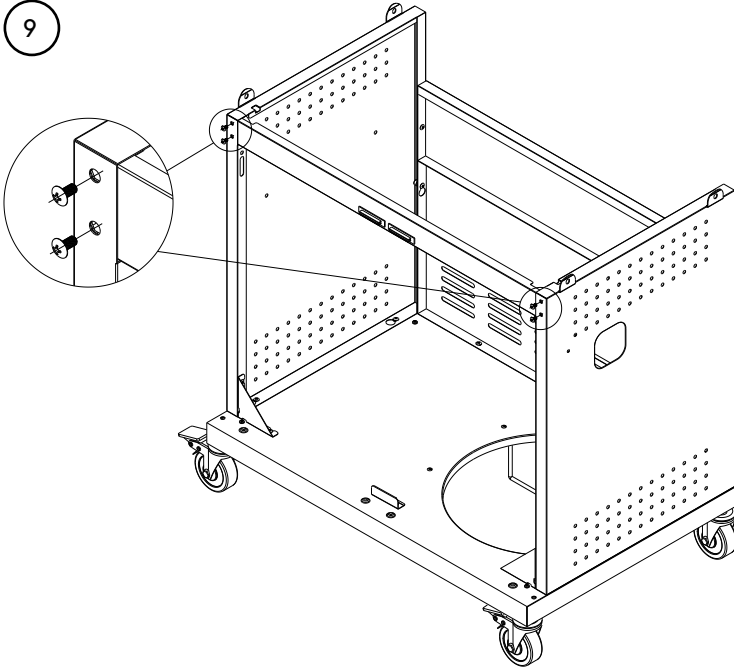

4 x A

10

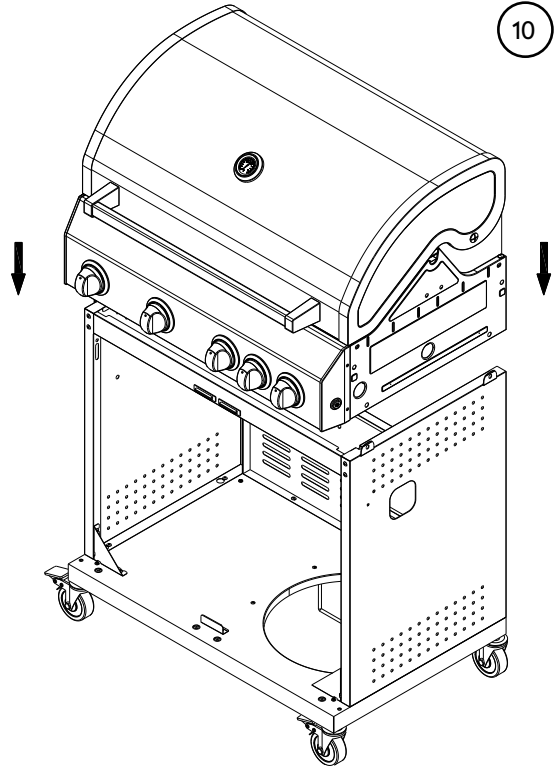

11

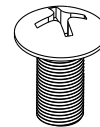
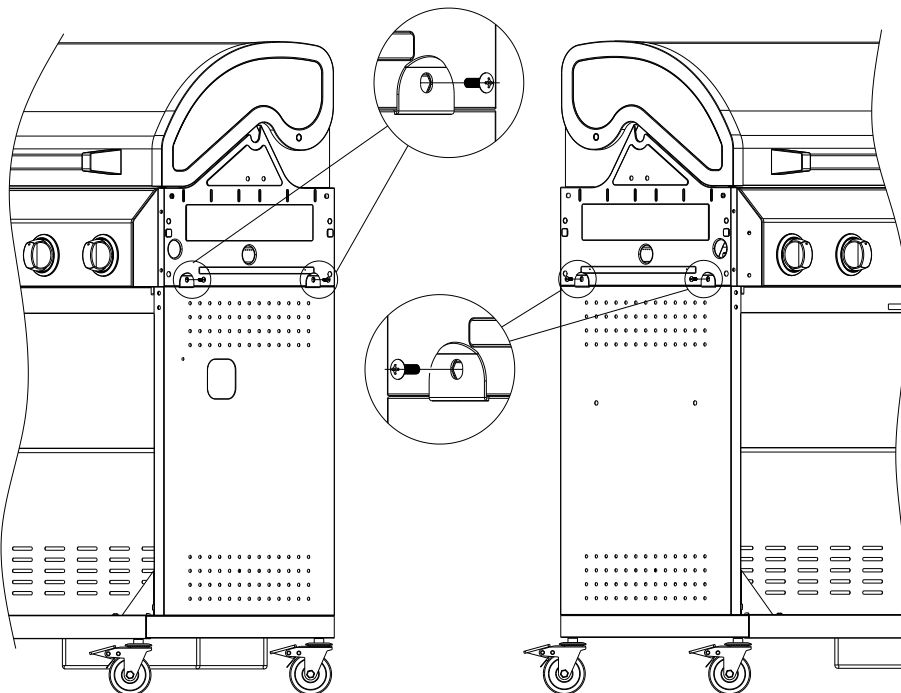

4 x B

12

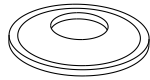
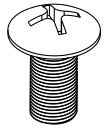

8 x B

4 x D

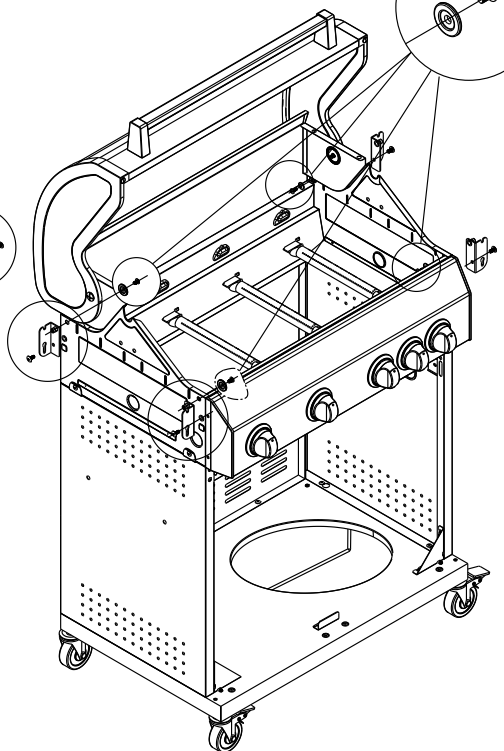
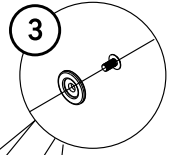
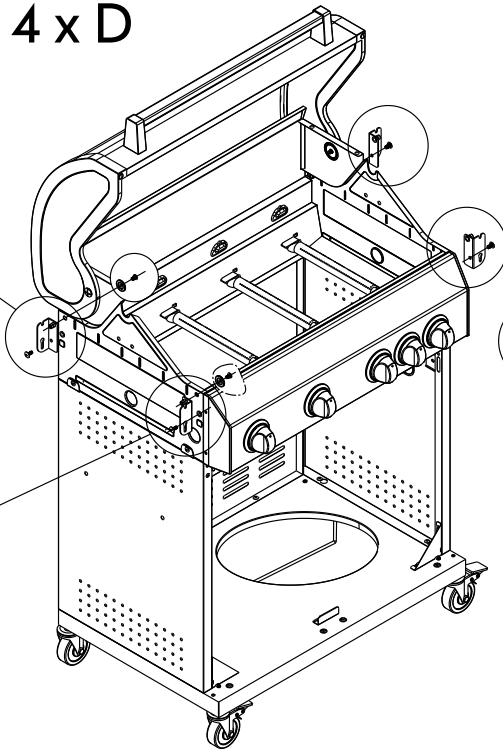
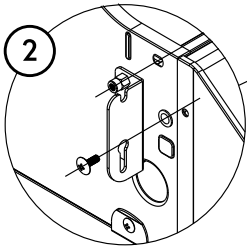
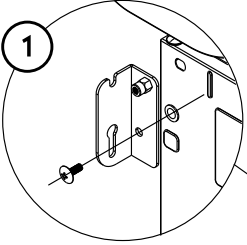

13

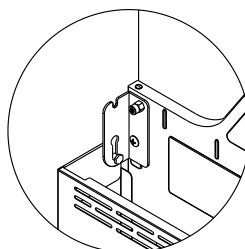
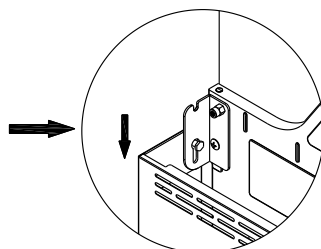
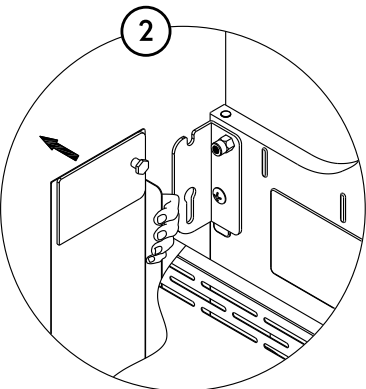
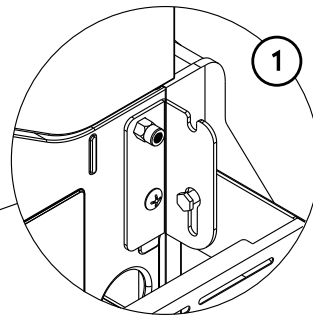
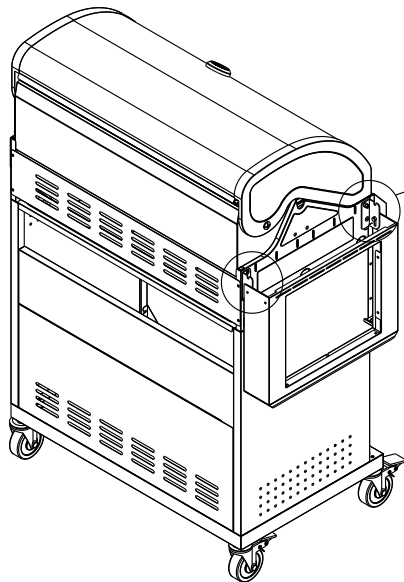

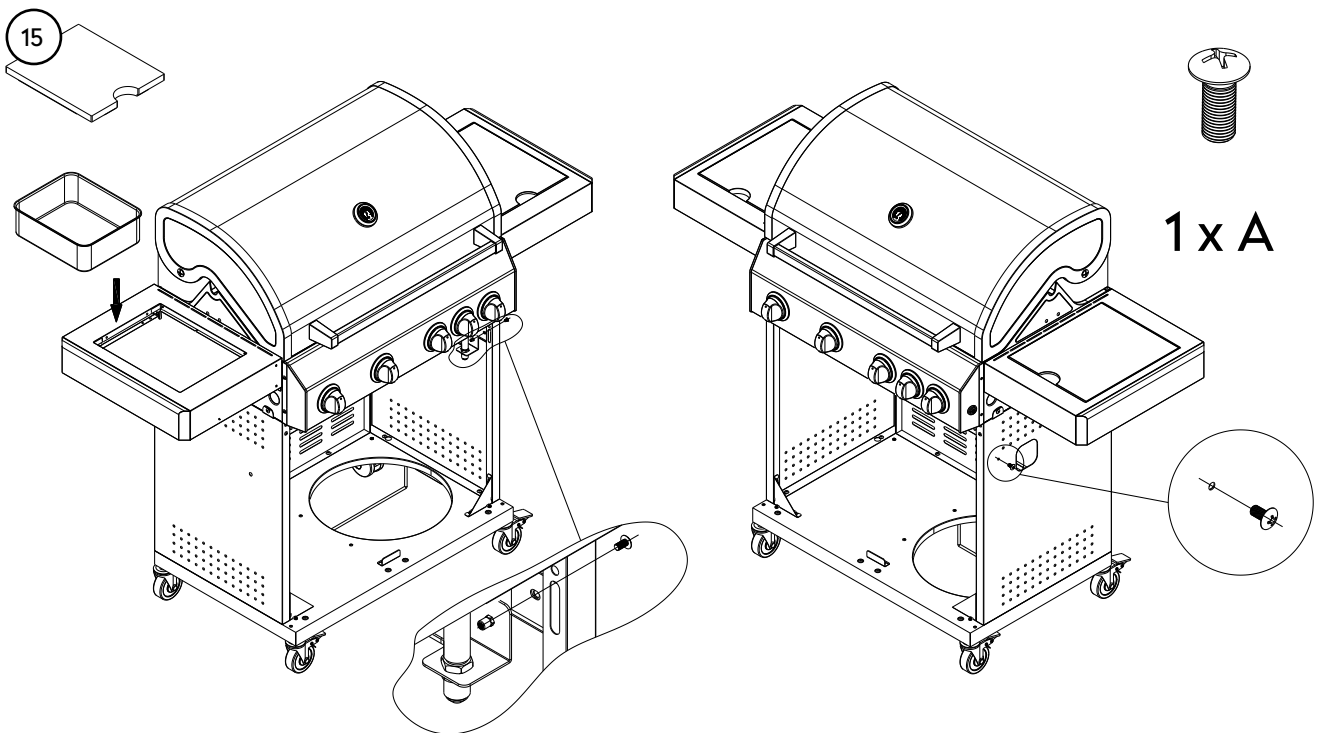
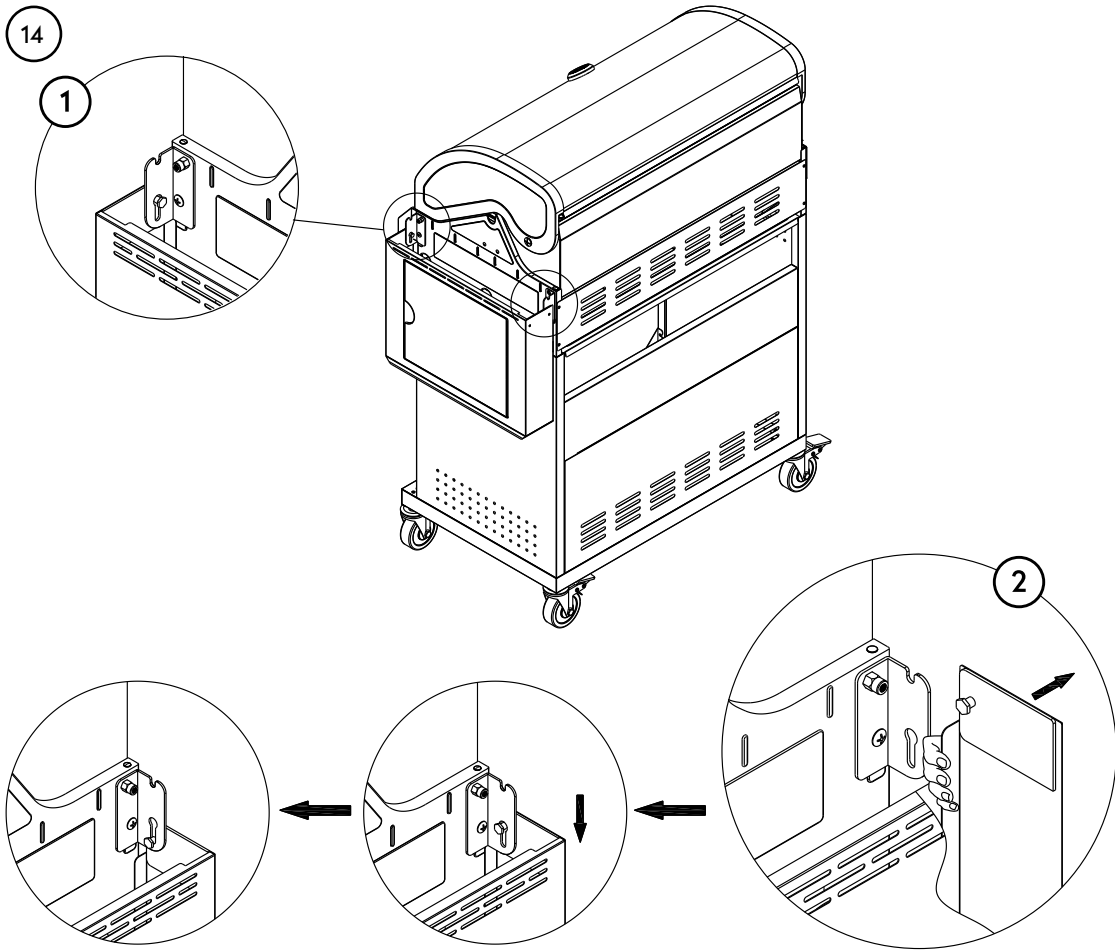

The gas distributor is attached with a cable tie below the console for transport. Untie the cable tie and attach the gas distributor to the side panel.

16

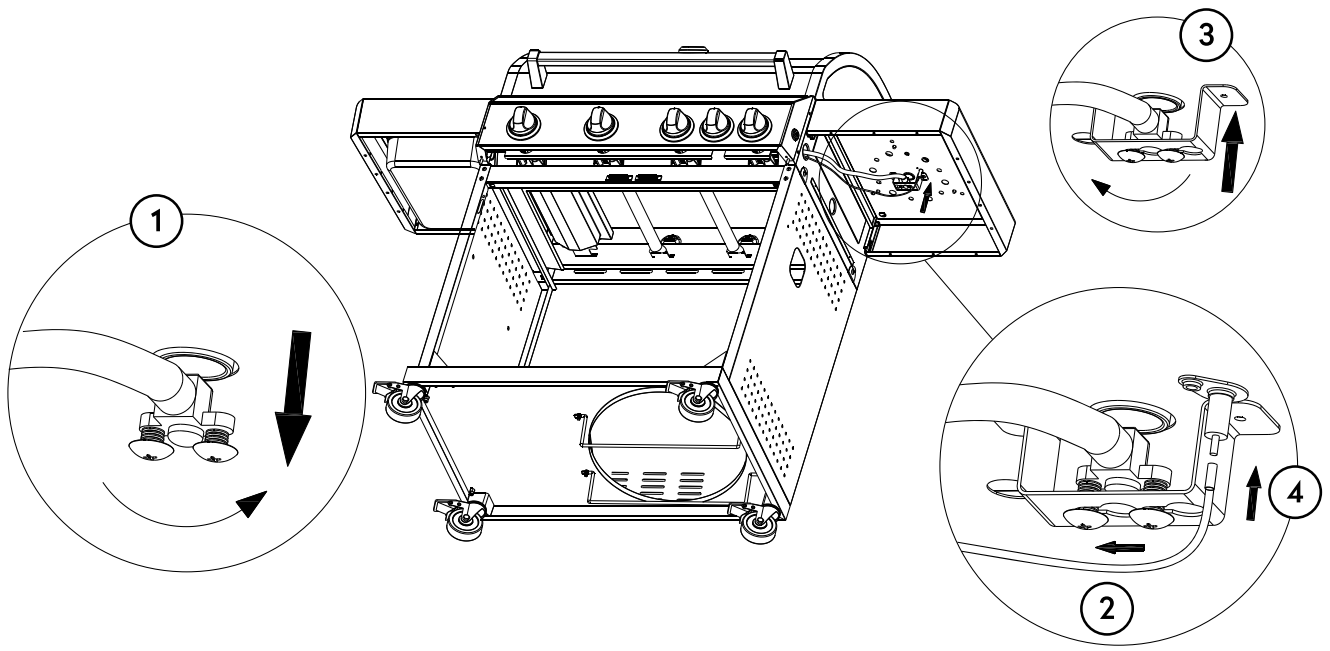

17

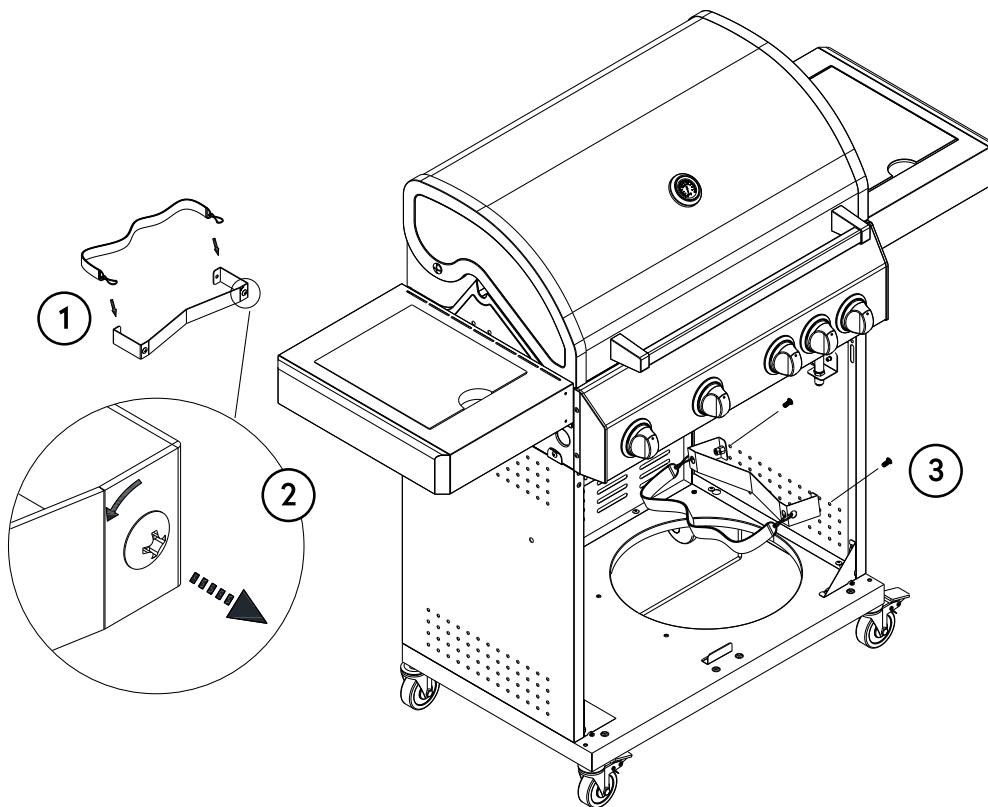

18

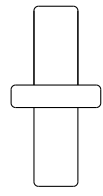

2 x C

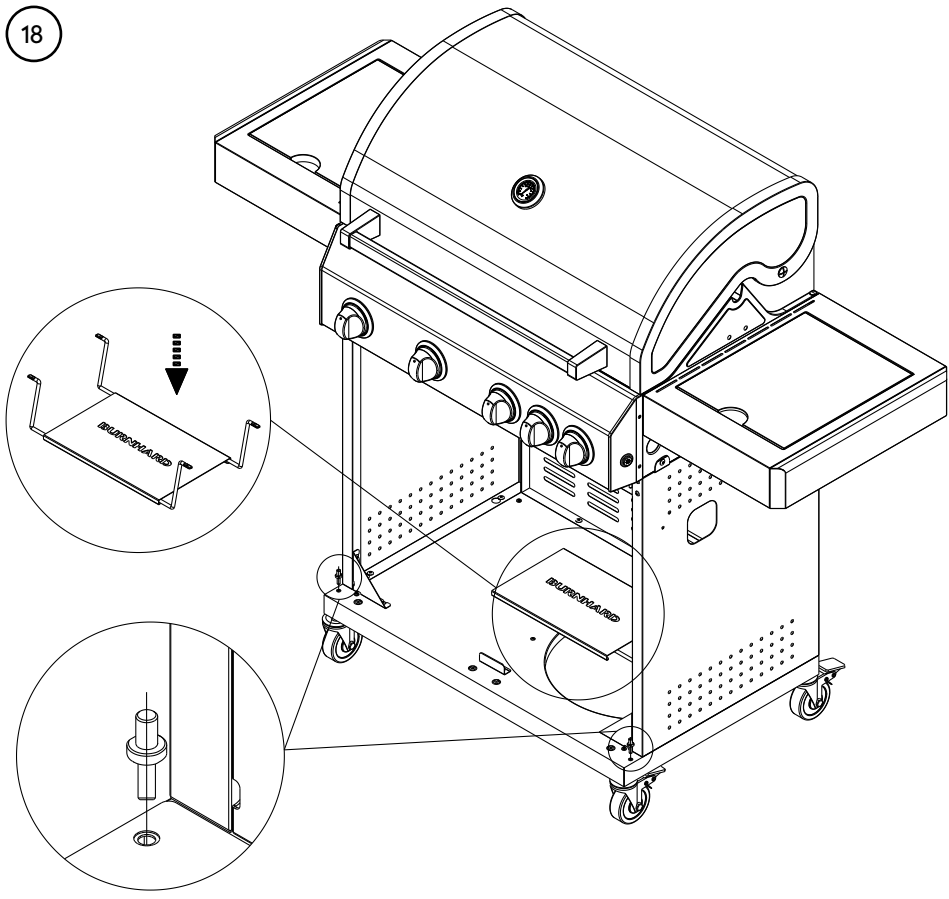

19

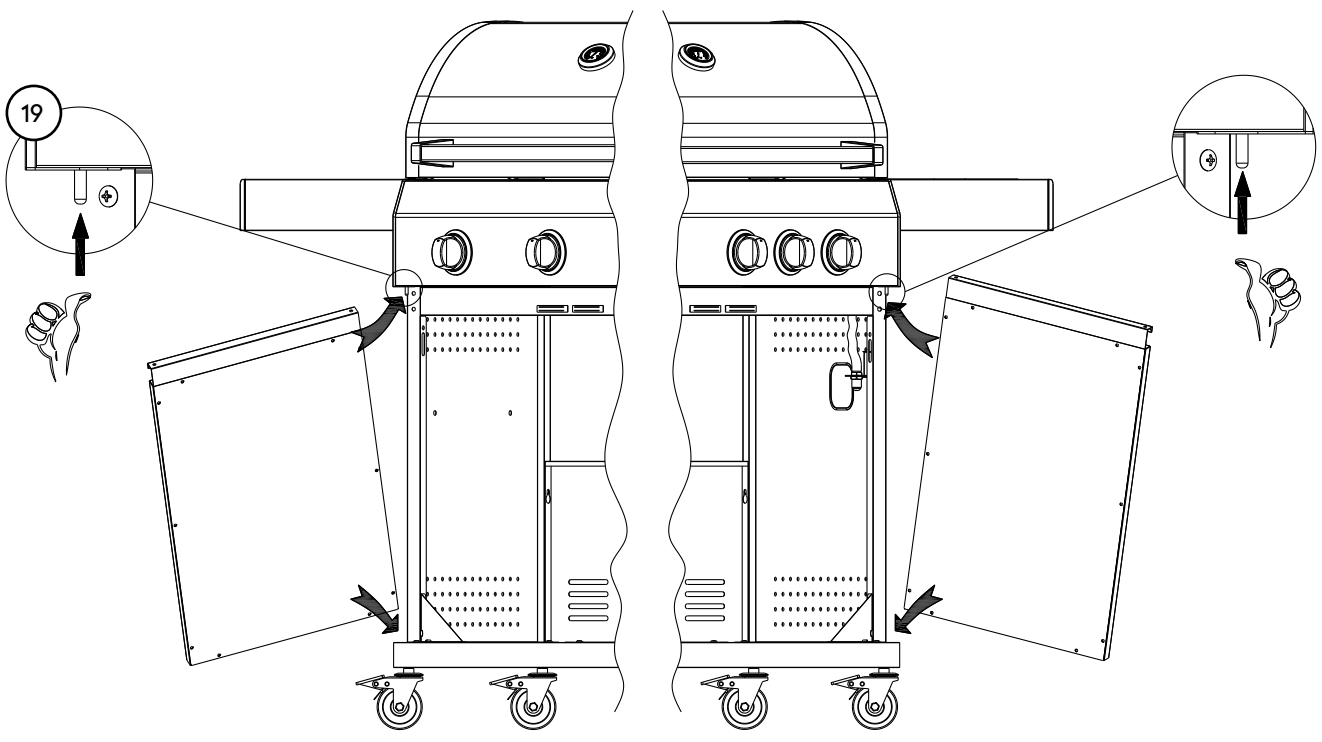

20

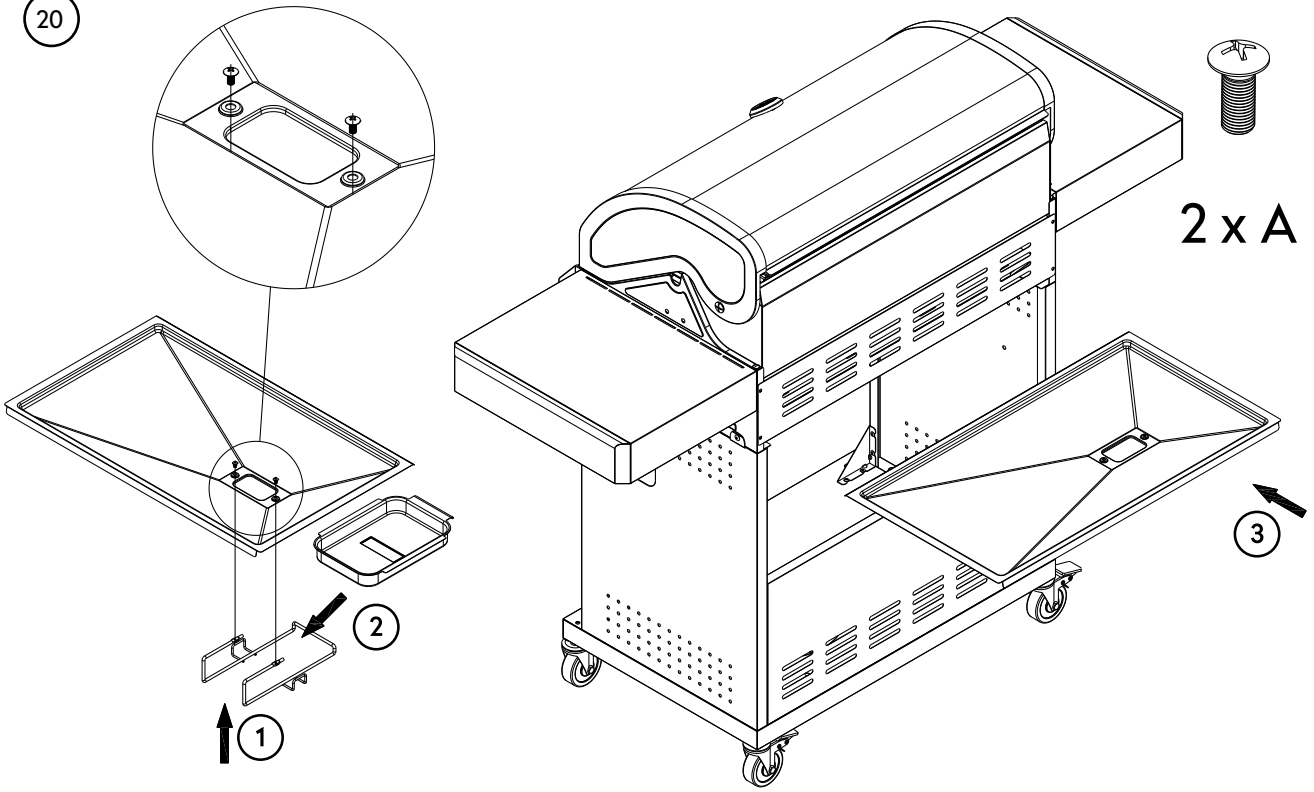

21

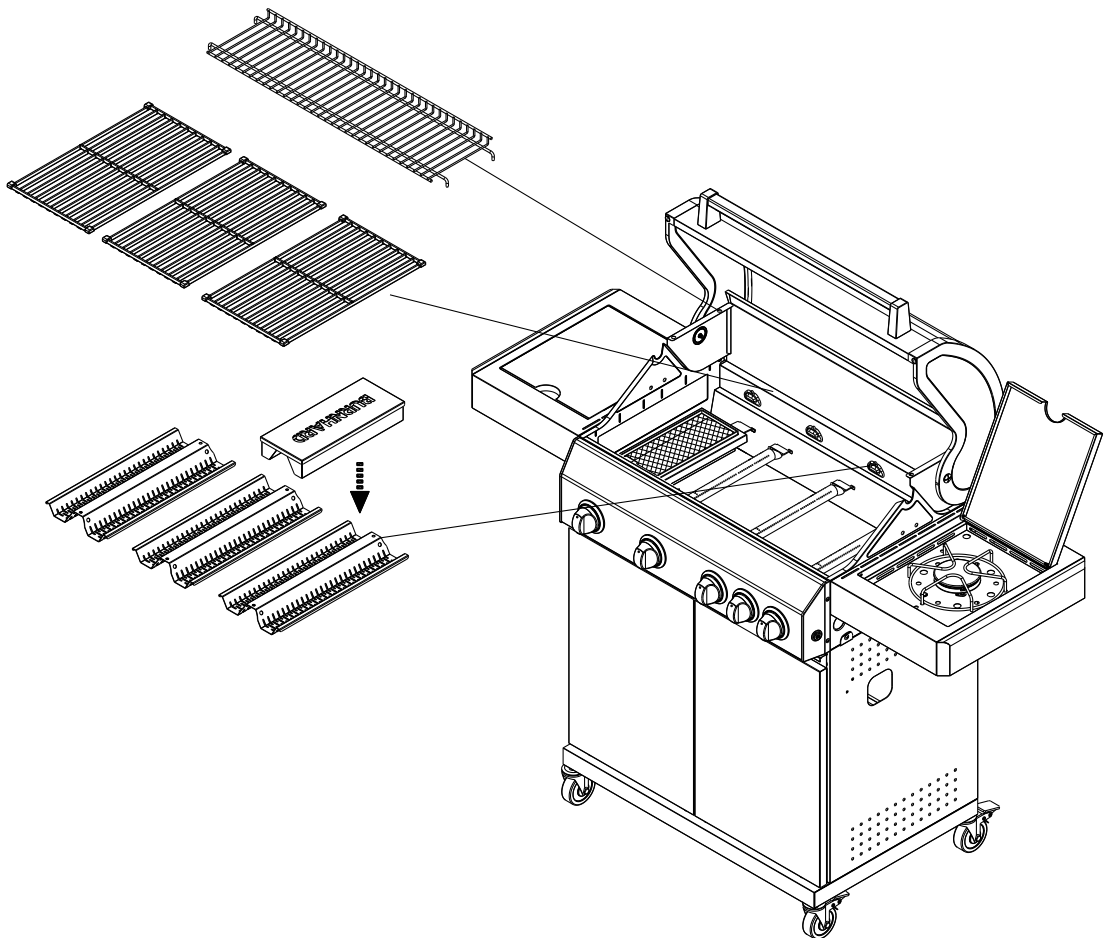

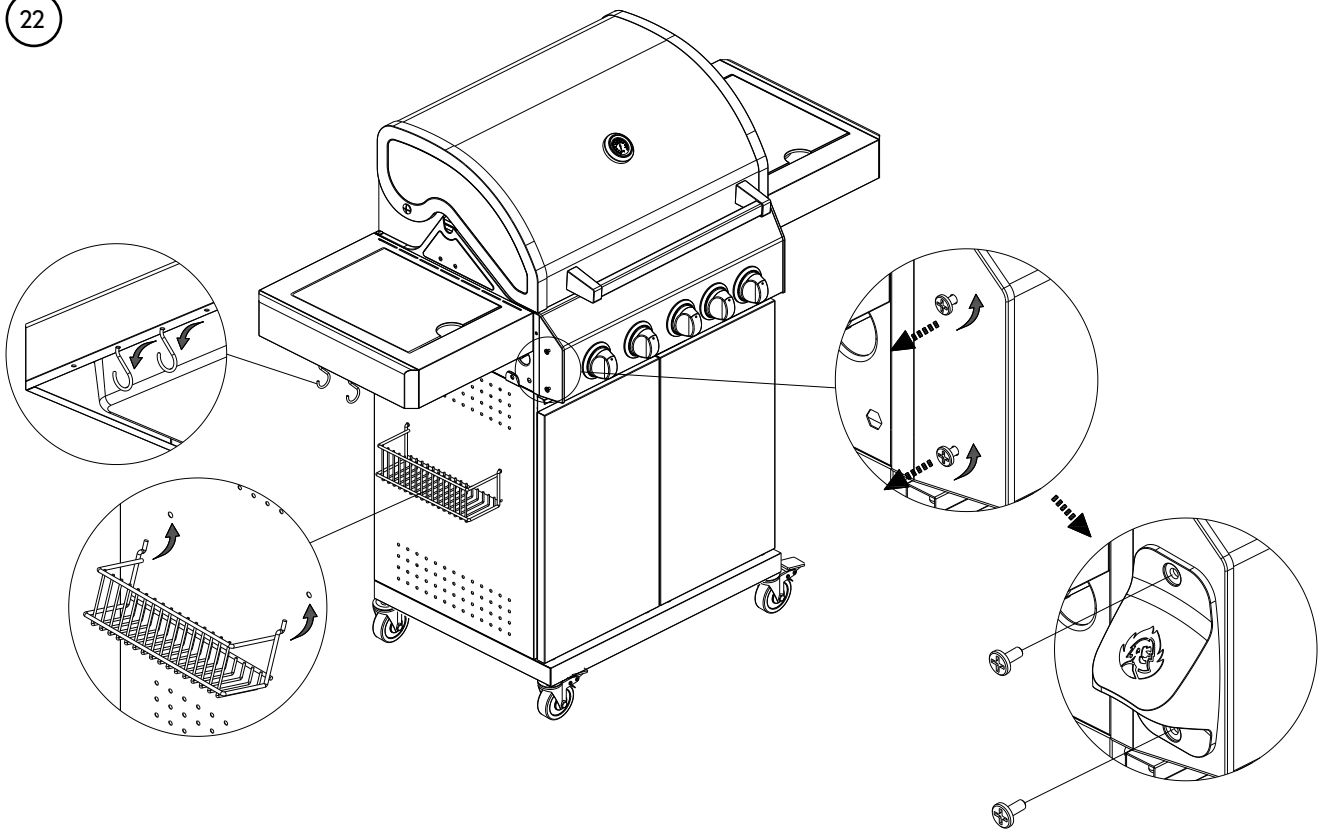

WARNING: The grill radiates heat. Never place the grill next to glass windows, walls, plants, etc.
The minimum distance to any kind of object is:

- Back: 60 cm
- Sides: 50 cm
- Top: 100 cm

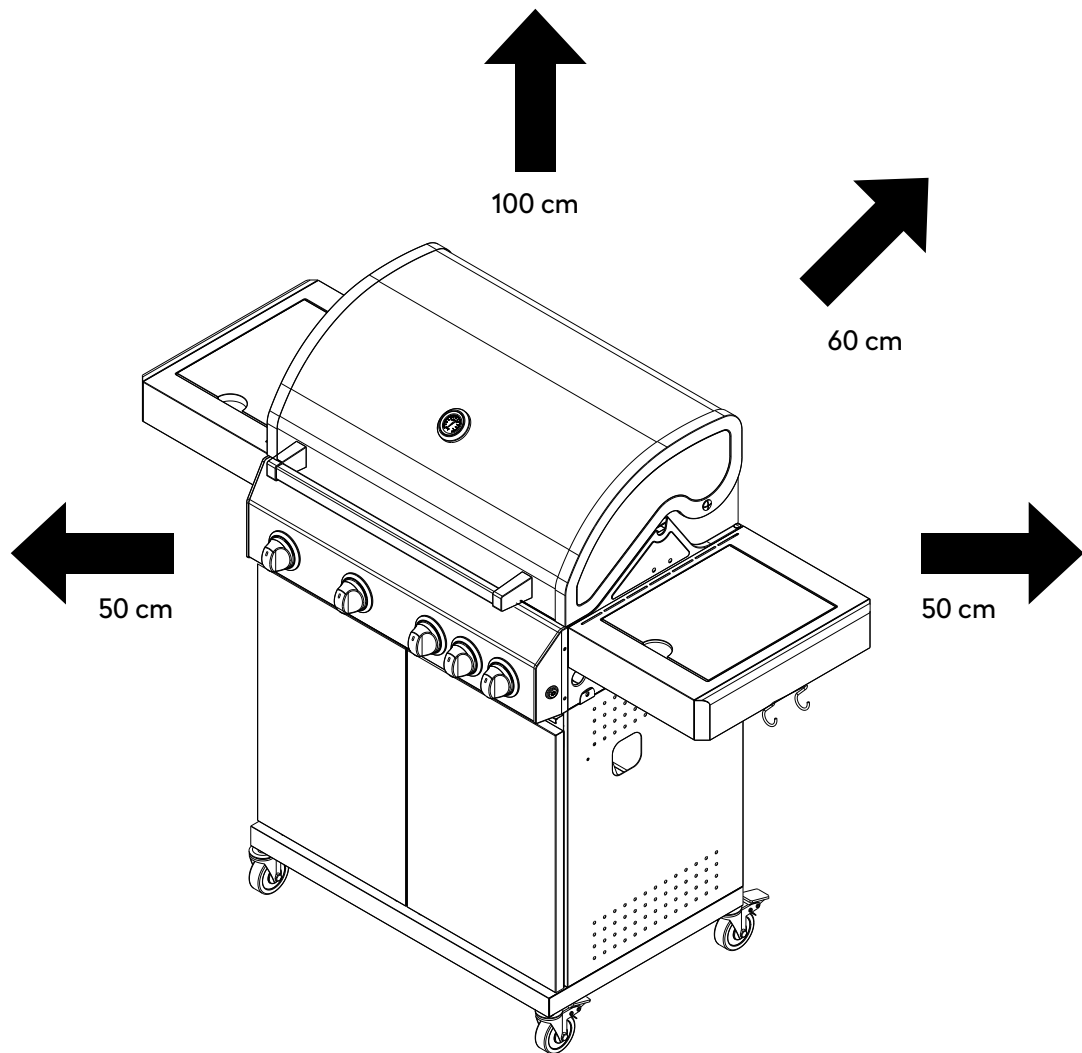

CONNECTING THE GAS CYLINDER



Fire and explosion hazard

WARNING: Never connect new or not completely empty gas cylinders if there are ignition sources in the immediate vicinity. Do not smoke.

The following parts are included. They comply with the applicable standard of the country in which the gas grill is supplied:

- Gas hose (pre-assembled): CE-approved hose line of sufficient length (maximum 1.5 m) that allows kink-free installation.
 - Pressure regulator (pre-assembled on the gas hose): Permanently adjusted and CE-approved pressure regulator in accordance with DIN EN 16129, max. 1.5 kg/h, operating pressure 50 mbar, suitable for the gas cylinder used.
1. Unscrew the protective cap from the screw connection on the gas grill. Screw the cap nut at the end of the hose onto the screw connection on the gas grill. Tighten the cap nut with a wrench.
 2. Place the gas cylinder in the trolley.
 3. Screw the hose cap nut onto the pressure regulator and tighten with a wrench.
 4. Screw the cap nut on the pressure regulator onto the screw connection on the gas cylinder. Tighten the cap nut by hand. Don't use tools to avoid damaging the seal.

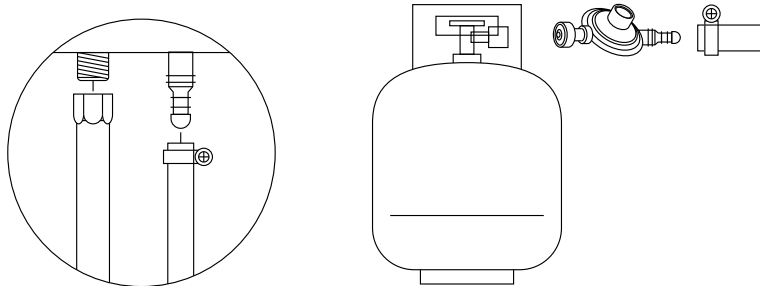

PERMITTED GAS CYLINDER SIZES

Gas cylinder sizes that may be operated and stored in the grill base:

5 kg (height 420 mm, diameter 200 mm)

8 kg (height 505 mm, diameter 229 mm)

11 kg (height 600 mm, diameter 300 mm)

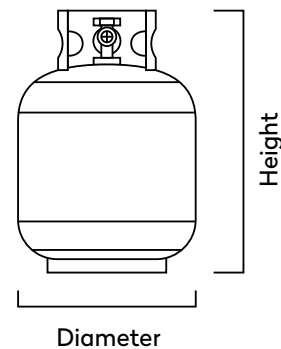

Fire and explosion hazard due to damage to the gas hose

WARNING: When placing the gas hose, ensure that the following requirements are met:

- The gas hose does not touch any hot surfaces.
- The gas hose does not run along sharp edges and corners.
- Hot grease or other liquids cannot drop onto the gas hose.
- The gas hose is not twisted or kinked at any point.

LEAK TEST

- Use a commercially available leak detection spray or paint brush and soapy water to check all connections (mixing ratio of soap to water: 1:3).

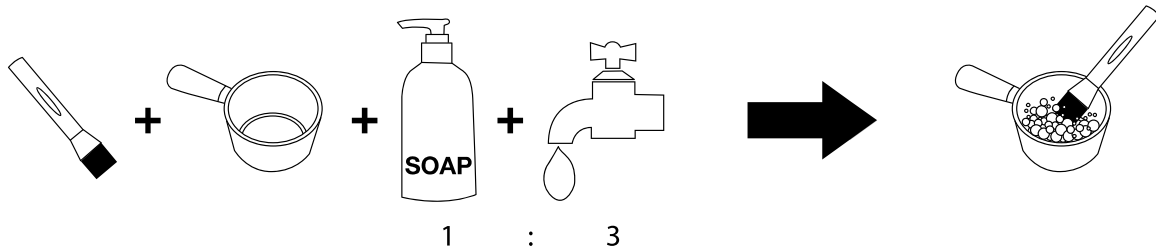

- Open the gas cylinder valve. Small bubbles will appear where there are leaks.

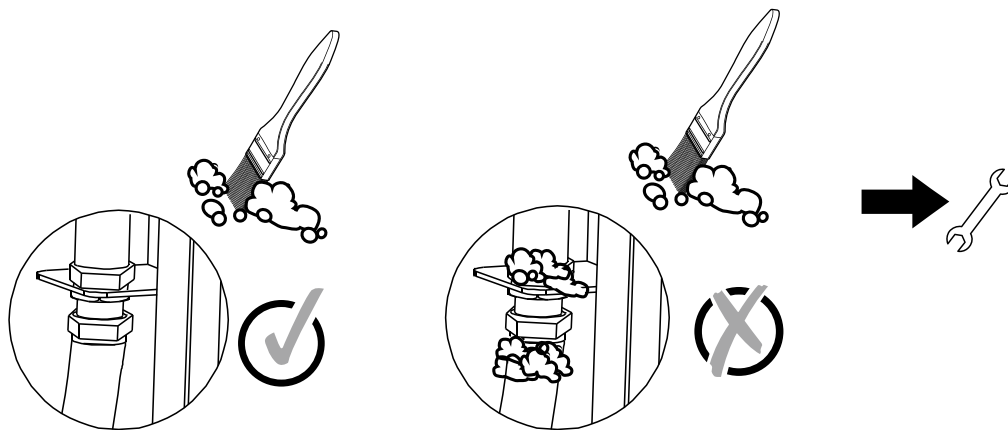

- Close the valve again.
- Tighten the nuts on both sides by hand again and repeat the leak test. If you still notice bubbles, close the gas valve and consult a specialist dealer.

Repeat the leak test every time you change the gas cylinder.

ENERGY SAVING TIPS

1. Turn the grill off as soon as you are done grilling.
2. Preheat the grill with the lid closed for only 10-15 minutes (except for the first use).
3. You do not need to preheat the grill longer than specified.



WARNING: Check the gas connections for breakages, wear, or tear before use. Should you notice any of these, do not use the grill until the issue has been resolved.

When replacing or unscrewing the gas cylinder, make sure there are no fire sources such as candles, electrical appliances, or cigarettes within reach. Always check to ensure the cylinder is properly closed.

OPERATING THE GAS GRILL



WARNING: Never switch the grill on with the lid closed.

Before you use the gas grill for the first time, you should first wipe the surface of the lid and the outer parts of the combustion chamber with a wet cloth. This will prevent any production residue from burning in.

WARNING: Check that all burners are correctly positioned in the respective nozzles and that all cables below are accessible before using the gas grill. If this is not the case, loosen the clamp springs, remove the burners, and reposition them on the nozzles. Then retighten the clamping spring.

Before grilling for the first time, allow it to burn for 40 minutes without food. Preservation residues are removed in this way. You need not worry if it results in a slight odour. This is harmless. Make sure the grill is adequately ventilated. Scrub the grids with a stainless steel brush afterwards.

The colour inside the gas grill can change slightly. This is a natural process.

IGNITING THE GAS GRILL

1. Open the grill lid.
2. Turn all control knobs clockwise to the "OFF" position.
3. Connect the pressure regulator to the gas cylinder.
4. Open the gas cylinder valve and use a leak detection spray or soapy water to check for leaks between the gas pressure regulator and the gas cylinder.
5. You can light the burners independently.
6. Press and hold down one of the knobs while turning it anticlockwise to the "HI" position. You will hear a "click" sound and the burner should ignite. If it does not ignite right away, repeat this step 3 to 4 times.
7. **WARNING:** If the burner does not ignite after repeated attempts, turn the knob clockwise to the "OFF" position and close the gas cylinder

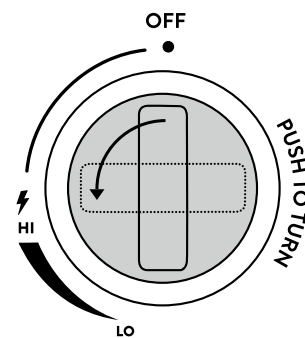

valve. Wait 5 minutes and then start again from step 4.

8. Once you have ignited the burner, repeat steps 6 and 7 with the other knobs to ignite the other burners.
9. Adjust the heat by turning the control knob to the desired setting between the highest ("HI") and lowest ("LO") levels.

USING THE INFRARED CERAMIC BURNER



WARNING: Never let the infrared ceramic burner preheat with the lid closed.

The burner heats up a ceramic brick perforated with little holes. The ceramic brick stores the energy, making particularly high temperatures possible. This way, you can easily make your steaks and burger patties super crisp without affecting the core temperature.

1. Open the lid of your grill.
2. Press the switch and turn it counterclockwise until you can hear the gas flowing in.
3. Count to 5 and ignite the burner by turning the knob a bit further and then you will hear the "click"

sound of the piezo ignition.

4. If the burner does not ignite, proceed exactly as with the stainless-steel burners.

The ceramic burner is continuously variable, just like a standard stainless-steel burner.

USING THE SIDE HOB



WARNING: The lid of the side cooking hob must always be open before ignition and during operation.

Use the side cooking hob as you would one of the burners in the combustion chamber. To ignite the side cooking hob, follow the instructions as described in the section IGNITING THE GAS GRILL.

WARNING: Never fold up the side table when the side cooking hob is in use. Make sure that the cooking hob and combustion chamber are completely cooled off before you fold up the side table.

SWITCHING OFF THE GAS GRILL

1. To turn off the gas grill, move the switch to "OFF" in clockwise direction.
2. Close the valve of the gas cylinder and move all switches clockwise to the "OFF" position.

CLEANING THE GAS GRILL



Fire and explosion hazard

- Do not use any flammable cleaning agents.
- Remove the gas cylinder before cleaning the gas grill.
- Wait until the grill has cooled down completely before cleaning.
- Clean the grill after each use.
- Remove the grease trap and dispose the grease in an environmentally friendly manner.
- Wipe the surfaces and grids using a wet cloth or clean them with hot water. If necessary, use a mild detergent and a soft sponge with a smooth surface. Rinse with water and allow the gas grill to dry completely before the next use. Alternatively, you can wipe the wet areas dry with a lint-free cotton cloth.
- Use a brush to remove food particles from the burners.
- If in exceptional cases one of the nozzles is blocked, use a jet needle to clean it.
- If in exceptional cases the Venturi tube (gas-mixing pipe) is blocked, use a needle or pipe cleaner to clean it.

Recommended equipment: stainless steel barbecue brush, soft cotton cloth (not microfiber), sponge, wooden scraper, bucket, suitable barbecue cleaner (for the interior), mild dishwashing detergent, possibly a scouring pad/steel wool, protective goggles, single-use gloves, splash guard for your upper body (apron)

CLEANING AFTER EACH USE

To prepare for your next barbecue session, you should let the grill burn out after every use (without food). This allows residue and grease on the grids to burn. Afterwards, you can simply brush them off.

1. Close the lid and set all stainless steel burners (not the side burner) to "HI". Set the infrared ceramic burners to "LO".
2. Let the grill burn out for 15–30 minutes until there is no more smoke coming out of the grill.

3. Close the gas cylinder valve and turn off all burners.
4. Slowly open the grill (be cautious of escaping heat) and scrub the grids with the stainless steel barbecue brush until clean.

NOTE: Brass brushes are incredibly soft and therefore not suitable for cast iron and stainless steel grids. They can also lead to staining and a residual rust film.

Once your grill has fully cooled down, empty and clean the grease drain plate and drip tray. If you covered your tray with aluminium foil, replace it.

CLEANING THE INTERIOR

To clean the inside of your grill, start by removing the grids, take out the grease drain plate, and remove coarse dirt. Empty and clean the grease drip tray.

1. To clear coarse dirt out of the flame distributors, take them out and let them soak in warm water with a little dishwashing detergent for 1 hour. Then clean them with a sponge, warm water, and dishwashing detergent. You can also clean them in the dishwasher. Dry thoroughly afterwards.
2. Release the safety clamps (by pressing down) from the burner heads and remove the stainless steel burners from your grill.
3. Insert the grease drain plate (without the drip tray) into the grill again and place the empty bucket beneath the opening.
4. Rinse out the interior of your grill with water (e.g. with a watering can). **WARNING:** Make sure that no water gets into the gas nozzles.
5. Apply a suitable cleaning agent for grill interiors (barbecue cleaner or dishwashing detergent) to the inside of the grill and let it soak for the amount of time indicated by the manufacturer. **WARNING:** Do not exceed the recommended application time of the cleaning agent used. Otherwise the material can become discoloured or damaged.
6. Remove stubborn stains in the interior of your grill with a sponge or a wooden scraper.
7. Thoroughly rinse your grill with water, let it dry completely, and carefully clean the burners and nozzle outlets with a dry cotton cloth (or a brush).
8. Insert the parts back into the grill.

CLEANING THE EXTERIOR

Clean the exterior of your grill with a soft cotton cloth, warm water, and mild detergent.

WARNING: Do not use a microfiber cloth to clean the surfaces – this would scratch the material.

MAINTENANCE OF THE CAST IRON GRIDS

The grids are enameled. This layer protects against rust and prevents food from sticking to the grids. Despite this protective layer, the grids can absorb and release grease and moisture. It is therefore advisable to let the grids burn-in as well.

BURNING IN THE CAST-IRON GRIDS

Cast iron grids must be given some time to burn in to protect the metal from rust and enable a non-stick surface. The burn-in process of cast iron can be performed in 3 simple steps:

1. Clean the cast iron grids with warm soapy water, rinse well, and wipe dry.
2. Grease the grids completely. Use an unrefined oil or fat with a low smoke point. **WARNING:** Never use olive oil or whey products - these become bitter when burned, have an unpleasant smell and cause heavy smoke.
3. Place the grids on the grill and set the stainless steel burners to "HI", the infrared ceramic burner to "LO". Let them burn-in for 45 minutes at the highest temperature with the lid closed. This burns the grease permanently onto the iron thus creating a protective patina.

MAINTENANCE OF THE STAINLESS STEEL GRIDS

Stainless steel grids do not need to be burned in. You can clean the durable grids with warm water, mild detergent and a sponge by hand or in the dishwasher.

Stainless steel can slightly discolour when exposed to high temperatures. This is a natural process and has no effect on the quality or your grilling result.

MAINTENANCE AND CLEANING OF THE INFRARED CERAMIC BURNER

The ceramic brick cannot be cleaned. Fat and meat juices dripping onto the ceramic brick will combust. Hence, staining of the brick and baked-on residues are normal and do not affect the burner's performance.



WARNING: Under no circumstances shall the ceramic brick be cleaned with water and/or detergents. If something falls through the protective grid and is not burnt completely, adjust the burner to the highest heat possible and let all residues combust for 10-15 minutes.

Make sure to only cook non-marinated grillables on the ceramic brick. Salty and acidic marinades or pepper may damage the ceramic brick when dripping down during cooking over long periods of time.

REGULAR MAINTENANCE

After grilling, you should prepare the grill for the next use. Let the grill burn freely at maximum heat with the lid closed to burn up any residues on the grids and then brush them off.

Follow the procedure below to do this:

1. Remove all grilled food from the grill and set the grill to maximum heat with the lid closed. Let it burn freely for 15-30 minutes until no more smoke comes out of the grill. For tough stains, turn the grids so that the used side faces the bottom.
2. Close the gas cylinder valve (rotate to OFF) and subsequently turn the control knobs to the OFF position.
3. Next, use a long-handled stainless steel brush to clean the grill. Make sure to wear grilling gloves or potholders since the grill is still very hot.
4. When using cast iron grids pour some rapeseed or sunflower oil on a cloth and rub it on the grids to prevent rust. Stainless steel grids need no further maintenance.

It is recommended that you clean the dirty spots on the edge of the cast iron grids separately every 2-3 times you use the grill. Here, you should first let the grill burn freely and then clean it using a wire brush. To clean the dirty spots on the edges, remove the grids from the grill and scrub them carefully under warm water (no detergent) using a wire sponge (pot sponge). Afterwards, use a cloth to dry them thoroughly, apply some oil, and place them back into the grill.

Stainless steel grids can easily be cleaned with detergent, sponge and warm water or in the dishwasher.

If the grids are rusty, scrub the rusty surfaces with steel wool until you have completely removed all the rust. Next, wash the grids with water or warm soapy water, dry properly, and repeat the burning-in process.

If possible, store the cast iron grids in a dry place during winter.

General cleaning of the grill should be done every 3-4 months. You should let the grease residues burn, empty the grease trap, and clean the grease tray and grids every time you use the grill.

WARNING: The enclosed wooden chopping board is a natural product and will expand due to moisture and weather conditions and/or mildew might set in. Therefore, store the chopping board in a dry and warm place after each barbecue and take it outside only when you barbecue.

Clean the board with a damp sponge after use. For heavier soiling, use some mild detergent. Never put the board in the dishwasher. Do not leave it in the dishwasher or water for a long time. Treat the cutting board regularly with a suitable maintenance oil.

TROUBLESHOOTING

Problem	Possible cause	Solution
Burner does not ignite	Gas cylinder is empty	Connect new gas cylinder
	Faulty pressure regulator	Have the pressure regulator checked by a specialist dealer
	Foreign debris in burner	Clean the burner
	Foreign debris in the ignition system or hose	Clean the ignition and hose
	No ignition spark	Replace the piezo ignition
	Nozzle defective (if the burners still do not ignite despite the previous recommendations)	Please contact our customer service to obtain a replacement
Small flame / little heat or flash fire in the burner	Foreign debris in burner	Clean the ignition and gas hose
	The burner is not positioned correctly	Remove the burner and reposition it

REPLACING THE STAINLESS-STEEL BURNERS

If one or more burners are defective, replace the affected burner(s) as follows:

1. Remove the clamping spring. Pull the burner back slightly and carefully lift out the corresponding burner.
2. Clean or replace the defective burner(s). Put the burners back in the reverse order and secure the burners with the clamping spring.

STORING THE GAS GRILL

- Store the gas grill in a dry room protected from frost. Close the lid and cover the unit to protect it from dirt and damage.
- A cover protects your grill from the weather such as rain, hail, snow, wind and frost all year round.
- Always close the gas cylinder valve and keep it out of the reach of children.
- Bring the cast iron into the house/flat during the winter season to prevent rust.
- Also observe the instructions for storage in the SAFETY INSTRUCTIONS section.

CUSTOMER SERVICE

In principle, our products have a legal warranty duty of 2 years. Further claims can only be processed in conjunction with a proof of purchase. Wearing parts exclude any warranty claims, when usual abrasion has occurred. The durability is determined by the respective handling and use of the products and is thus variable.

For questions concerning handling and functionality of our products, please contact our customer service:

Free hotline for Germany/Austria only: 0800 270 70 27

From other EU countries: +49 211 - 749 55 10*

*Different costs may apply.

E-Mail: service@burnhard.de

Internet: www.burnhard.de

DISPOSAL/RECYCLING



Our products are manufactured to high quality standards and are designed for a long service life. Regular maintenance and care will help to extend service life. If the appliance is defective and can no longer be repaired, it must not be disposed of in the normal household waste.

The product and its packaging must be disposed of in accordance with local regulations. Contact your local waste disposal company if necessary.

DECLARATION OF CONFORMITY

The Springlane GmbH hereby declares that this product conforms to the basic CE requirements as of the day of publication. The full declaration of conformity can be found at www.burnhard.de.