

3-Drawer Rolling Service Cart with Locking Lid

Manual

Model: TMG-SC03D

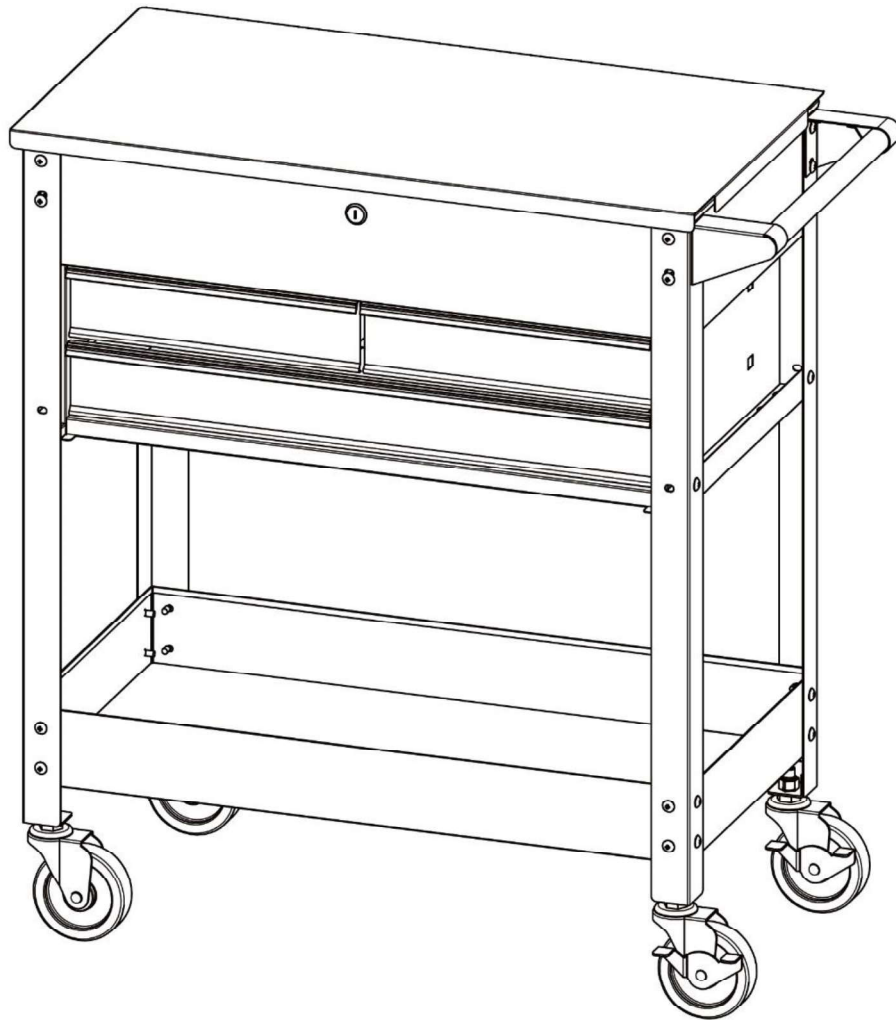



WARNING !

READ, STUDY AND UNDERSTAND ALL WARNINGS BEFORE USING.
PERSONAL INJURY AND UNIT DAMAGE COULD OCCUR IF
INSTRUCTIONS ARE NOT FOLLOWED.

- ▶ DO NOT OVERLOAD DRAWERS.
- ▶ DO NOT OPEN MORE THAN ONE LOADED DRAWER AT A TIME, TIPPING MAY OCCUR.
- ▶ TO PREVENT POSSIBLE DAMAGE TO THE UNIT, CLOSE LID AND MAKE SURE DRAWERS AND DOORS ARE IN THE LOCKED POSITION BEFORE ATTEMPTING TO MOVE.
- ▶ DO NOT STAND ON THE PRODUCT. DO NOT STEP IN THE DRAWERS. YOU MAY FALL WHICH MAY CAUSE PERSONAL INJURY AND/OR PROPERTY DAMAGE.
- ▶ DO NOT MOUNT THE PRODUCT ON TRUCK BED OR ANY OTHER MOVING OBJECT.
- ▶ APPLY BRAKES ON SWIVEL CASTERS WHEN NOT MOVING UNIT.
- ▶ DO NOT PULL. PUSH TO MOVE.
- ▶ LUBRICATE THE TOP AND BOTTOM CHANNELS OF THE DRAWER SLIDES AT LEAST TWICE A YEAR.

OPERATING INSTRUCTIONS

If you need to remove the drawers, follow these instructions

1. **To disassemble ball bearing sliders:** Simultaneously press the plastic lock spring up or down and pull the inner drawer slide out.
2. **To reassemble:** insert the end of the inner drawer slide into the middle drawer slide fully into place.

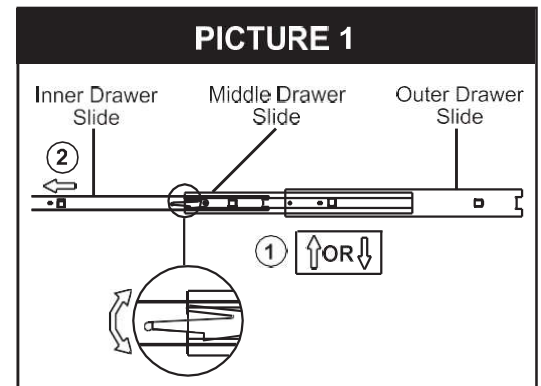

WARNING: Before using this appliance, read this Operator's Manual and follow all its Safety Rules and Operating Instructions.

AVERTISSEMENT: veuillez lire ce manuel d'utilisation et observer toutes les règles de sécurité et les consignes d'utilisation avant d'utiliser cet équipement.

ASSEMBLY

1. Using (16) attach the casters to corner frame (3) one by one.

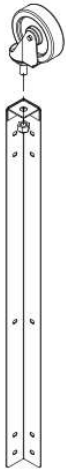

2. Using (15) and (17) to connect the corner frame (3) and bottom tray (8)



NOTE: Pay attention to the assembly direction of corner frame.

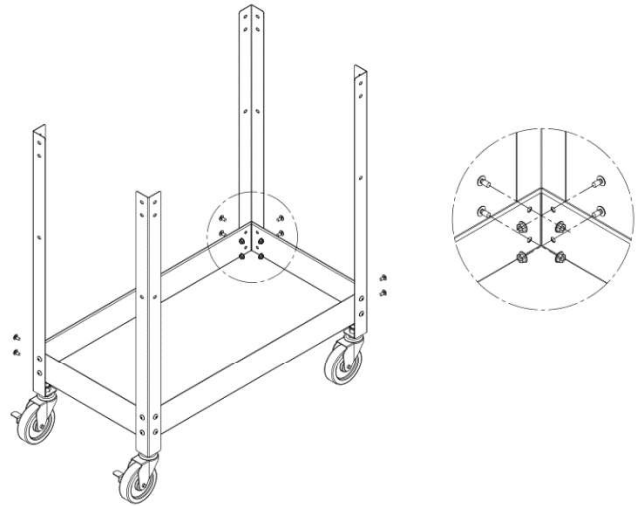

3. Using (15) to attach (3).

4. Using (3) to attach 4 of (15).



NOTE: leave 2 holes open for handle.

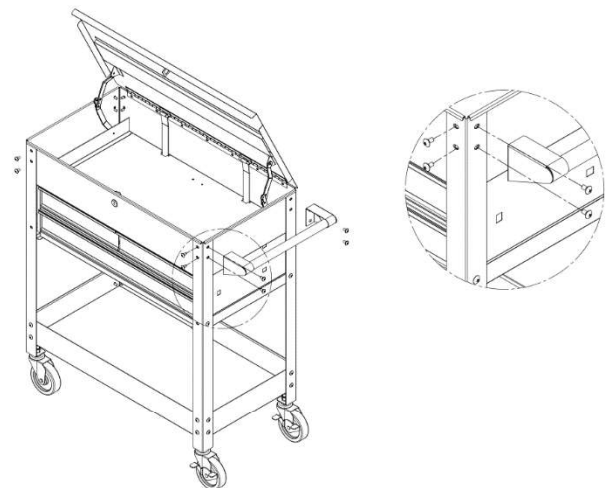
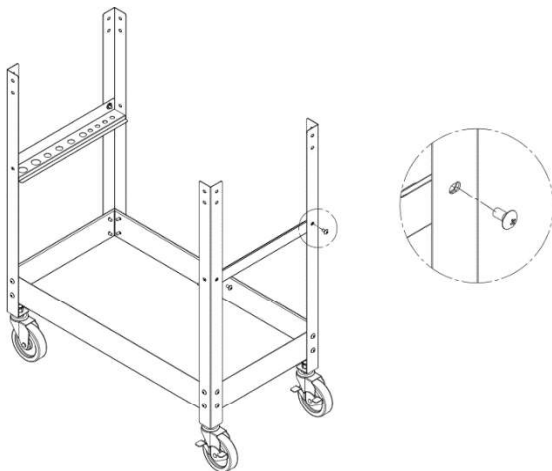

OPERATION

1. Locking and unlocking the unit

IMPORTANT: The drawers must be fully closed before locking / unlocking the unit.

1. To lock the unit, insert the key (I) into the lock cylinder (10) and turn it to the left. Then remove the key.
2. To unlock the unit, insert the key (I) into the lock cylinder (10) and turn it to the right. Then remove the key.

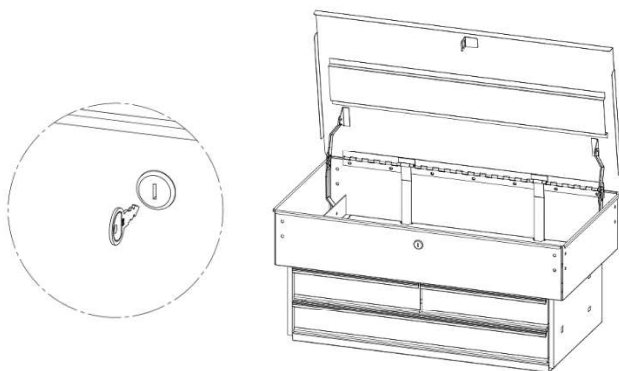

2. Removing the drawers

CAUTION: Do not over tighten the screws.

1. Fully extend and empty the drawer.
2. Depending on the slide, either lift or lower the release lever on both sides so the slides can ride over the stops. Pull out to remove.

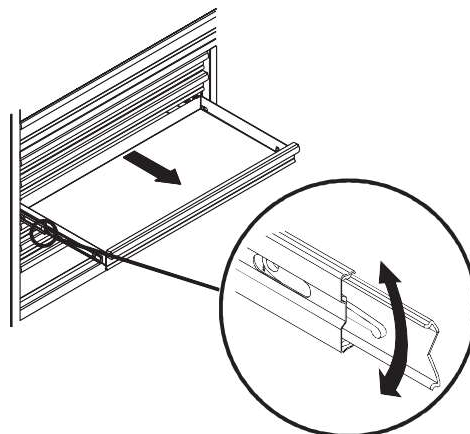

3. Installing the drawers

1. Pull the slides and slide carrier out until fully extended.
2. Hold the slide on the cabinet while aligning it with the slide on the drawer.
3. Slightly insert one side and repeat for the other side.
4. Slowly push the drawer until it is fully closed to engage the slide.
5. Open the drawer and close it to verify proper operation.

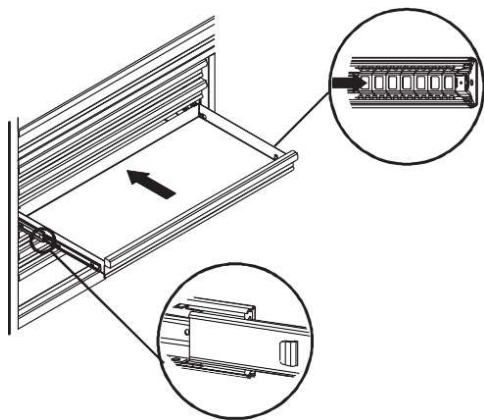

MAINTENANCE

1. Maintaining the casters

Grease the casters annually using high quality bearing grease.

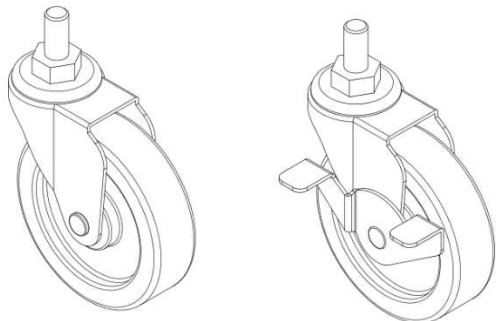

2. Maintaining the drawers

1. Periodically clean the drawer trim and inside the drawers with a mild detergent and water.
2. Remove grease and oil with a standard, nonflammable cleaning fluid.
3. The use of drawer liners is recommended to protect the finish inside the drawers and make the drawers easier to clean. Drawer liners can be cleaned with soap and water.
4. Lubricate the slides semi-annually with grease or equivalent.

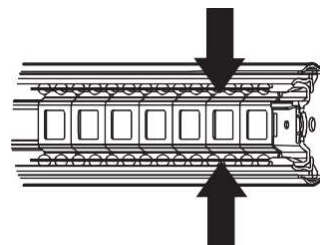

CARE AND CLEANING

1. Grease the casters annually using high quality bearing grease for a durable finish.
2. To help protect the powder-coated finish, do not allow harsh chemicals (oil, grease, or other chemicals) to remain on the powder coating surface.
3. Use a glass cleaner (Windex or equivalent product) to clean and maintain all surfaces of powder coating.

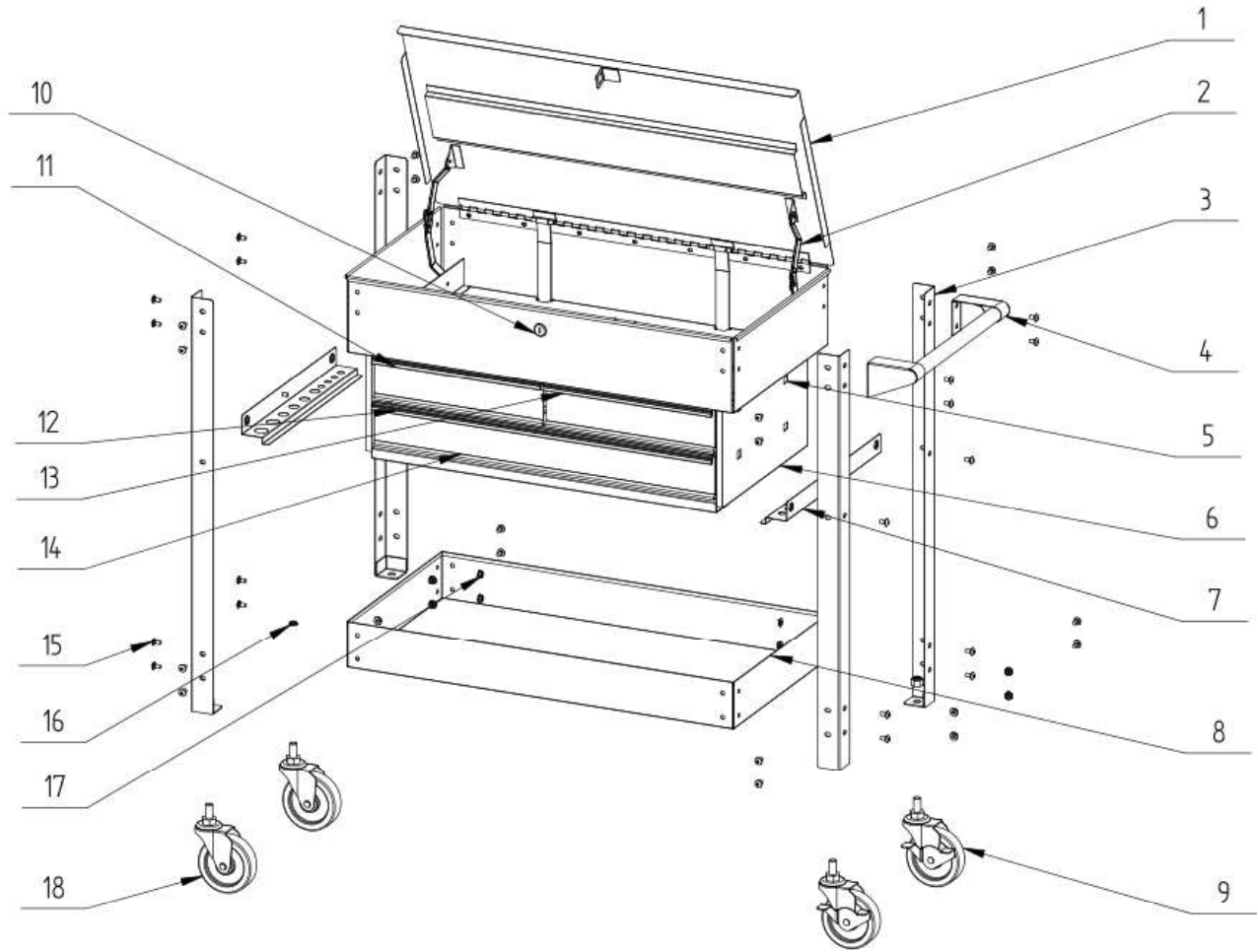

Part List	Description	Quantity
1	Lid	1
2	Manual Lift	2
3	Corner Frame	4
4	Handle	1
5	Drawer Slide	4
6	Drawer Assembly	1
7	Pry Bar Holder	2
8	Bottom Tray	1
9	Swivel Caster with Brake	2

Part List	Description	Quantity
10	Lock with 2 keys	1
11	Small Drawer	2
12	Long Drawer Pull	1
13	Small drawer pull	2
14	Bottom Drawer	1
15	M6x12 Head Bolt	36
16	M12 locknut	4
17	M6 Hex Flange Nut	32
18	Swivel Caster	2