

9 FT SKID STEER SWING BACKHOE ATTACHMENT

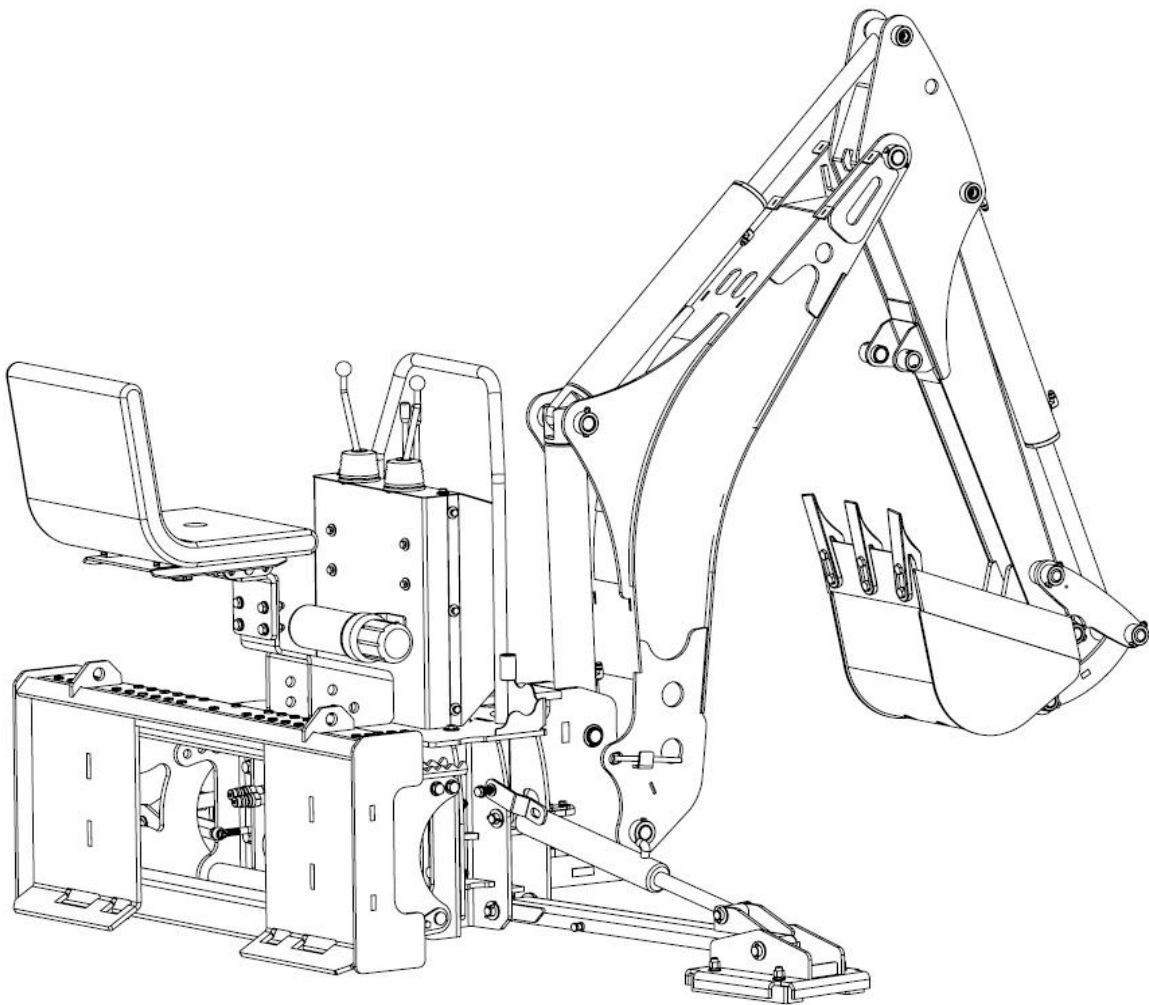

⚠ WARNING

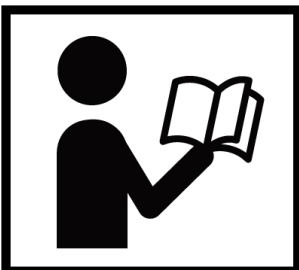

- Please read and understand the product manual completely before assembly
- Check against the parts list to make sure all parts are received
- Wear proper safety goggles or other protective gears while in assembly
- Do not return the product to dealer. They are not equipped to handle your requests.

Missing parts or questions on assembly?

Please call: 1-877-761-2819 or email: cs@tmgindustrial.com

TABLE OF CONTENTS

IMPORTANT SAFETY INFORMATION.....	3
SAFETY DECAL LOCATIONS	8
PARTS DESCRIPTION AND FUCTION.....	10
PRODUCTS SPECIFICATIONS.....	11
UNPACKING & ASSEMBLY.....	12
CONNECTING SKID STEER LOADER.....	20
CHECK BEFORE OPERATING.....	21
LUBRICATION POINTS SUMMARY.....	22
CONTROLS.....	23
OPERATING ESSENTIAS.....	25
OPERATING FINISH.....	30
MAINTENANCE SCHEDULE.....	31
TROUBLE SHOOTING.....	32
EXPLODED VIEW & PARTS LIST.....	33

IMPORTANT SAFETY INFORMATION



Before operating the BACKHOE read the following safety instructions. Failure to comply with these warnings may result in serious injury or death.

Safety Instructions

The alert symbol is used throughout this manual and this manual and on the product safety decals. This symbol indicates attention is required and identifies hazards concerning your personal safety and the safety of others. Please follow the recommended precautions



The safety alert symbol means...
ATTENTION! BECOME ALERT! YOUR SAFETY IS INVOLVED!



DANGER

Indicates an imminently hazardous situation that, if not avoided, will result in death or serious injury. This signal word is to be limited to the most extreme situations typically for machine components which, for functional purposes, cannot be guarded.



WARNING

Indicates a potentially hazardous situation that, if not avoided, could result in death or serious injury, and includes hazards that are exposed when guards are removed. It may also be used to alert against unsafe practices.



CAUTION

Indicates a potentially hazardous situation that, if not avoided, may result in minor or moderate injury. It may also be used to alert against unsafe practices.

NOTICE - Indicates a situation that could result in damage to the machine or other property.

Safety Rules

It is the operator's responsibility to read, understand and follow ALL safety and operation instructions in this manual. If you do not understand any part of this manual and require assistance, contact your dealer.



The operator of this backhoe must be a responsible, physically able person familiar with machinery and trained in this machine's operation.

Provide instructions to anyone else who is going to operate the machine. This equipment is dangerous to anyone unfamiliar with its operation.

Review safety related items annually with all personnel who will be operating or performing maintenance.

Make sure all safety signs on the machine are understood before operating, servicing, adjusting or cleaning. Being unfamiliar with a machine can lead to injuries.

Replace any safety sign or instruction sign that is not readable or is missing.

Never exceed the limitations of the machine. If its ability to do the job, or to do it safely is in question—**STOP!**

Have a first-aid kit and fire extinguisher available for use should the need arise and know how to use them.

Do not modify the equipment in any way. Unauthorized modifications may affect the integrity of the machine or the ability of the machine to perform as designed. Modifications can impair safety or function. They can affect the life of the equipment and void warranty.

Make sure the suspension is correctly mounted and all hardware is torqued to specifications to prevent backhoe from moving when digging.

Never operate the backhoe without the top link installed. Make sure it is correctly adjusted to prevent the backhoe from being pushed upward by digging force. If the backhoe moves upward the operator can be crushed against the ROPS, FOPS, or cab. Make sure there is adequate head room for the operator.

The skid steer loader must be equipped with a front loader and ROPS (Roll Over Protection Structure) or ROPS cab. Always wear your seat belt when operating the skid steer loader.

Do not install backhoe if the total machine weight exceeds the ROPS weight certification.

Ensure suspension is firmly attached and all hardware is torqued to specifications to prevent backhoe from moving when digging.

Operating Safety

- Wear appropriate Personal Protective Equipment (PPE) when using this machine.

This includes but is not limited to:

- Hard hat
 - Hearing Protection
 - Protective shoes with slip resistant soles
 - Protective glasses
- Always wear hearing protection if the noise in any area you work in exceeds 80 dB.
 - Noise over 85 dB on a long-term basis can cause severe hearing loss.
 - Exposure to noise over 90 dB over a long-term basis may cause permanent, total hearing loss.
 - Hearing loss from loud noise (from engines, chainsaws, radios, and other such sources close to the ear) is cumulative over a lifetime, without hope of natural recovery.
 - Know your controls and how to stop engine and attachment quickly in an emergency.
 - Be aware of overhead hazards: branches, cables, electrical wires. Have an underground utility locating/marketing service survey the area before digging.
 - Keep boom and bucket away from overhead and underground power lines and utilities. High-voltage power lines can cause electrocution without direct contact.
 - Be sure machine is properly mounted, adjusted and in good operating condition.
 - Follow the **Pre-operation Checklist** before starting work.



- If the backhoe is powered by the tractor / skid steer hydraulic system, oil pressure and flow must be properly matched. If a PTO drive is used, be sure speed is correct and PTO shaft is properly shielded.
- Never operate controls from the ground. Operate only from the operator's seat to prevent unexpected boom movement that can lead to crushing between frame members. Ensure all control levers are in neutral or off position before starting.
- Keep all bystanders in the designated safe zone during operation. Never carry, lift or move people on boom or bucket.
- Do not allow riders on this machine at any time. There is no safe place for any riders.
- Have an assistant on site to help you stay aware of situations that may be dangerous. Have the assistant stay in the designated safe zone, wearing bright, reflective clothing.
- Inspect and secure all guards before starting.
- Before exiting the equipment, always lower the bucket to the ground and engage the parking brake.
- Operate the equipment at a speed that allows you maintain control at all times. Drive slowly over rough terrain and avoid obstacles.
- Use extreme caution on inclines and edges where the ground could give way.
- Do not try to turn on a steep slope as this could result in a roll-over.
- Face the equipment when getting on and off. Maintain 3-point contact with steps and handrails.
- Never operate this machine under the influence of alcohol or drugs. Consult your doctor about using this machine while taking prescription medications.
- Do not dig under machine or stabilizers. A cave-in could result causing the machine to fall into the excavation.
- Do not exceed machine lift capacity. Overloading can cause structural damage and lead to unsafe operating conditions.
- Position backhoe so that loads extend directly behind machine when lifting or placing heavy objects.
- Do not walk or work under a raised machine or attachment unless it is securely blocked or held in position. Do not depend on the skid steer loader's hydraulic system to hold the load.
- Keep stabilizers and front bucket on the ground to stabilize the machine. Skid steer loader's wheels must be resting on the ground during operation. Working with the wheels raised off the ground could result in serious injury or death and may cause damage to the machine.
- Be careful operating the skid steer bucket/ loader controls if the backhoe is attached that way. It could cause damage to the tractor subframe or skid steer tieback.
- Train all new personnel and review instructions frequently with existing workers. Be certain only a properly trained and physically able person uses the machinery. A person who has not read and understood all instructions is not qualified to use the machine. An untrained operator can cause possible serious injury or death.
- If this machine is used by any other person, loaned or rented, it is the owner's responsibility to make certain that prior to using, every operator:
 - has read and understands the instructions in the operator's manual
 - is instructed in safe and proper use of the equipment
 - knows how to place the machine in a Safe Condition (see next page)

Safe Condition

Throughout this manual, we talk about a '*Safe Condition*'. What this means is parking the machine in a manner that makes it safe to service or repair.

Place the machine in a Safe Condition before performing any service, maintenance work or storage preparation by performing the following:

- Install boom and swing lock pins, or rest bucket on ground.
- Shut off hydraulic system.
- Set parking brake and shut off engine. Remove ignition key.
- Ensure all components have stopped moving.
- Block or chock wheels.

Maintenance Safety

- Have at least two workers present when performing maintenance on this equipment. Never work alone in case an emergency should arise.
- Keep service area clean and dry.
- Never operate the engine in a closed building. Make sure there is plenty of ventilation. Exhaust fumes can cause asphyxiation.
- Never work under unsupported equipment.
- Use only genuine OEM replacement parts. The manufacturer is not responsible for injuries or damage caused by the use of non-approved parts or accessories.
- Make sure all safety shields and devices are re-installed when a maintenance or service procedure is finished.
- Do not use gasoline or diesel fuel when cleaning any parts. Use a regular cleanser.
- Use proper tools that are in good condition. Make sure the procedure is understood before performing any service work.

Hydraulic System Safety

- Make sure that all the components in the hydraulic system are kept clean and in good condition.
- Make sure all components are tight, and that lines, hoses and couplings are not damaged before applying pressure to the system.
- Do not use your hand to check for hydraulic oil leaks. Hydraulic fluid escaping under pressure can penetrate the skin causing serious injury. Use a piece of cardboard instead.
- Wear proper hand and eye protection when searching for a high-pressure hydraulic leak.
- Seek medical attention immediately if injured by a concentrated high-pressure stream of hydraulic fluid. Serious infection or toxic reaction can develop from hydraulic fluid piercing the skin surface.
- Do not attempt any makeshift repairs to the hydraulic lines, fittings or hoses by using tape, clamps or cements. Doing so can cause sudden failure and create a hazardous and unsafe condition.
- Relieve pressure on the hydraulic system before working it. The hydraulic system operates under extremely high pressure.
- Replace any hydraulic hose immediately that shows signs of swelling, wear, leaks, or damage before it bursts.
- Do not bend or strike high-pressure lines, tubes or hoses, or reinstall them in a bent or damaged condition.
- Check to make sure hydraulic hoses are not worn or damaged, and are routed to avoid chafing.
- Never adjust a pressure relief valve or other pressure-limiting device to a higher pressure than specified.

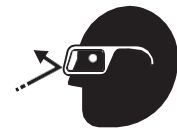

Safe Zone

For safety of others during operation, set up a **Work Zone** around the machine. Mark the area with safety cones. Outside of that would be considered a designated **Safe Zone** for other workers or bystanders.

Always know where all workers and bystanders are when operating the backhoe. Have them stay outside of the work zone in the designated Safe Zone. They should only enter the work zone when:

- The person has made eye contact with and signaled the backhoe operator.
- The backhoe is in transport position or backhoe bucket is resting on the ground.
- The engine is shut off.

Work Zone

Establish a Work Zone perimeter the length of maximum boom reach and swing arc. Mark an additional area at least 3 ft (1 m) around the stabilizers.

While using the backhoe, always be aware of bystanders in the area. A swinging boom can create a collision hazard to workers or bystanders. Injury may occur from heavy material falling or dropping from the bucket.

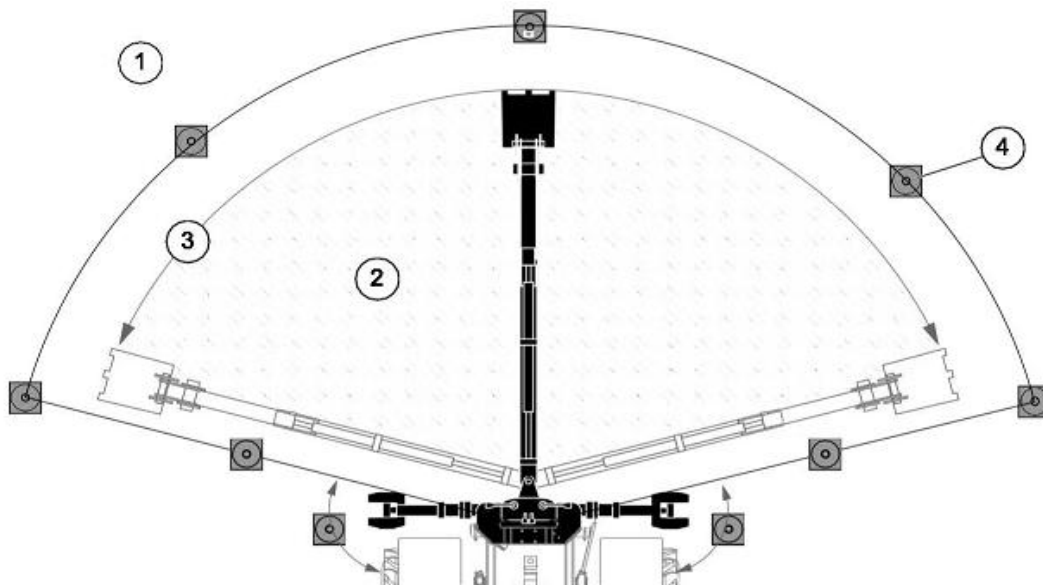

Fig. 1 – Establish work zone perimeter

1. Designated Safe Zone
2. Work Zone
3. Boom Swing Arc
4. Safety Cones

Safety within your work zone

The safest place for the operator is in the operator's seat.

Always operate the backhoe controls from the operator's seat.

Always be aware of the position of the boom and material being handled.

Be aware of bystanders and workers when lowering stabilizers. Make sure they are in the safe zone where they cannot be injured.

Always be aware of hazards such as:

Underground utilities

Tree roots

Structures close to the excavation site

Excavating on a slope

Excavating too close to the stabilizers

Modify your work zone to account for overhead hazards:

Telephone lines

Tree branches

Roof overhang

Wash lines, ropes or cables

Power lines—maintain a 20 ft (6 m) distance. Electrocution can occur without direct contact (arcing).

SAFETY DECAL LOCATIONS

The safety decals and their positions are shown on the illustration below. Good safety requires that you familiarize yourself with the various safety decals, the type of warning and the area or specific function related to that area that requires your SAFETY AWARENESS.

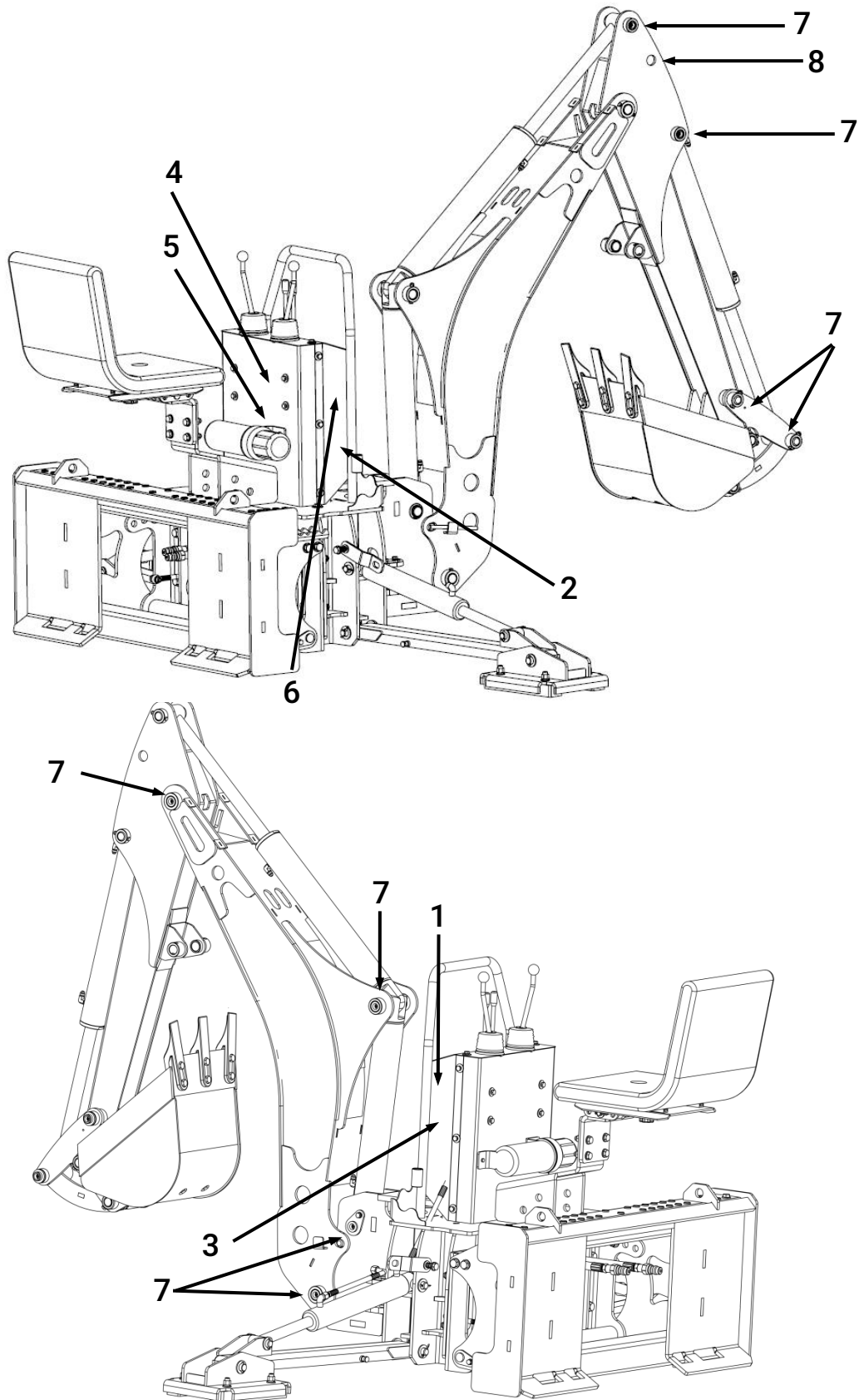

Warning Decals

⚠ DANGER

CRUSHING HAZARD

DO NOT OPERATE 3-POINT RIGID MOUNT BACKHOE ATTACHMENT UNLESS HITCH AND STABILIZER BARS ARE INSTALLED PROPERLY. FAILURE TO DO SO MAY RESULT IN SERIOUS INJURY OR DEATH BY BACKHOE BEING THRUSTED UPWARD BY DIGGING FORCES-CRUSHING THE OPERATOR.

OPERATOR'S AREA(SHADED AREA OF 40" RADIUS FROM SEAT TO 10" BEHIND SEAT) MUST BE FREE FROM ALL OBSTRUCTIONS.

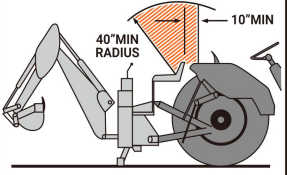

USE SPECIAL HITCH PARTS SUPPLIED WITH BACKHOE ONLY. SEE OPERATOR'S MANUAL FOR PROPER ASSEMBLY AND ADJUSTMENT OF HITCH

TMG-ATTA-2032

(1)

⚠ IMPORTANT

IMPROPER TRANSPORTING METHODS CAN CAUSE SERIOUS DAMAGE TO THE TRACTOR

- ENGAGE BOTH SAFETY LOCKS WHEN TRANSPORTING BACKHOE.
- TRAVEL SLOWLY OVER ROUGH TERRAIN.
- WHEN TRANSPORTING ON TRUCK OR TRAILER, LOWER BACKHOE BOOM SO BUCKET RESTS FIRMLY ON BED. APPLY RESTRAINTS TO TRACTOR, NOT TO BACKHOE OR HITCH.

TMG-ATTA-2034

(2)

⚠ IMPORTANT

IMPROPER HYDRAULIC HOOKUP CAN CAUSE SERIOUS DAMAGE TO VALVE.

- REFER TO ATTACHING KIT OR PTO PUMP KIT MANUAL FOR PROPER HYDRAULIC HOOKUP.
- NEVER PRESSURIZE RETURN PORT OF VALVE OR RESTRICT RETURN HOSE.
- ALWAYS MOVE TRACTOR 3-POINT HITCH CONTROL TO FULLY LOWERED POSITION WHILE BACKHOE IS MOUNTED TO TRACTOR.

TMG-ATTA-2035

(3)

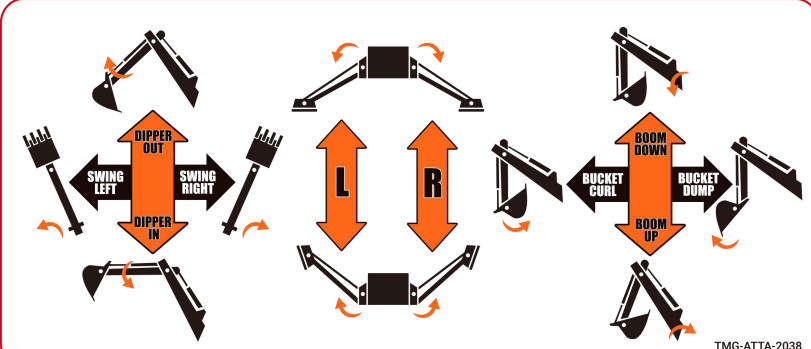

TMG-ATTA-2038

(4)

⚠ DANGER

1. READ OPERATOR'S MANUAL BEFORE USING BACKHOE.
2. OPERATE BACKHOE CONTROL ONLY FROM NORMAL BACKHOE OPERATOR'S SEAT POSITION.
3. OPERATE ONLY WITH STABILIZERS DOWN AND ON FIRM FOOTING. AVOID DIGGING IN AREA OF STABILIZER PADS. STAY AWAY FROM STEEP AREAS OR EXCAVATION BANKS THAT COULD GIVE WAY.
4. CHECK THE OPERATING AREA TO BE DUG FOR ANY POSSIBLE OVERHEAD OR UNDERGROUND LINES SUCH AS ELECTRIC, GAS, OIL, WATER, ETC. EXTREME CAUTION MUST BE EXERCISED IN THESE AREAS WHERE PRESENT. CONSULT LOCAL UTILITIES BEFORE DIGGING.
5. KEEP BYSTANDERS AWAY FROM MAXIMUM SWING AREA REACH AND STABILIZERS.
6. KEEP ALL GUARDS IN PLACE.
7. INSPECT BACKHOE DAILY FOR LOOSENED, BENT, OR BROKEN PARTS.
8. ENGAGE SAFETY LOCKS BEFORE TRANSPORTING OR SERVICING BACKHOE.
9. BE SURE TRACTOR IS WEIGHTED TO PROVIDE AT LEAST 20% OF TOTAL WEIGHT ON THE FRONT WHEELS WITH BACKHOE IN TRANSPORT POSITION.
10. DO NOT USE TRACTOR WITH HYDRAULIC SYSTEMS THAT EXCEED 8 GPM FLOW RATE OF 2500 PSI OPERATING PRESSURE.
11. FOR 3-POINT RIGID MOUNT BACKHOES ONLY: MOUNT ONLY TO TRACTORS FROM 25 TO 45 PTO HP WITH CATEGORY 1 OR 2 3-PT HITCH. 1050 LB LIFT FORCE REQUIRED AT 24" BEHIND LIFT POINT

TMG-ATTA-2033

(6)

DO NOT UNDER ANY CIRCUMSTANCES USE THE BACKHOE STABILIZER ARMS TO RAISE AN ATTACHED TRACTOR FROM THE GROUND - OFF OF ITS REAR WHEELS



FAILURE TO FOLLOW ADVISED SAFETY PROCEDURES MAY RESULT IN SERIOUS INJURY OR EVEN DEATH

TMG-ATTA-2037

(5)

GREASE



TMG-QNRL-0011

(7)

TMG-MACH-4029



LIFT POINT

(8)

PARTS DESCRIPTION AND FUCTION

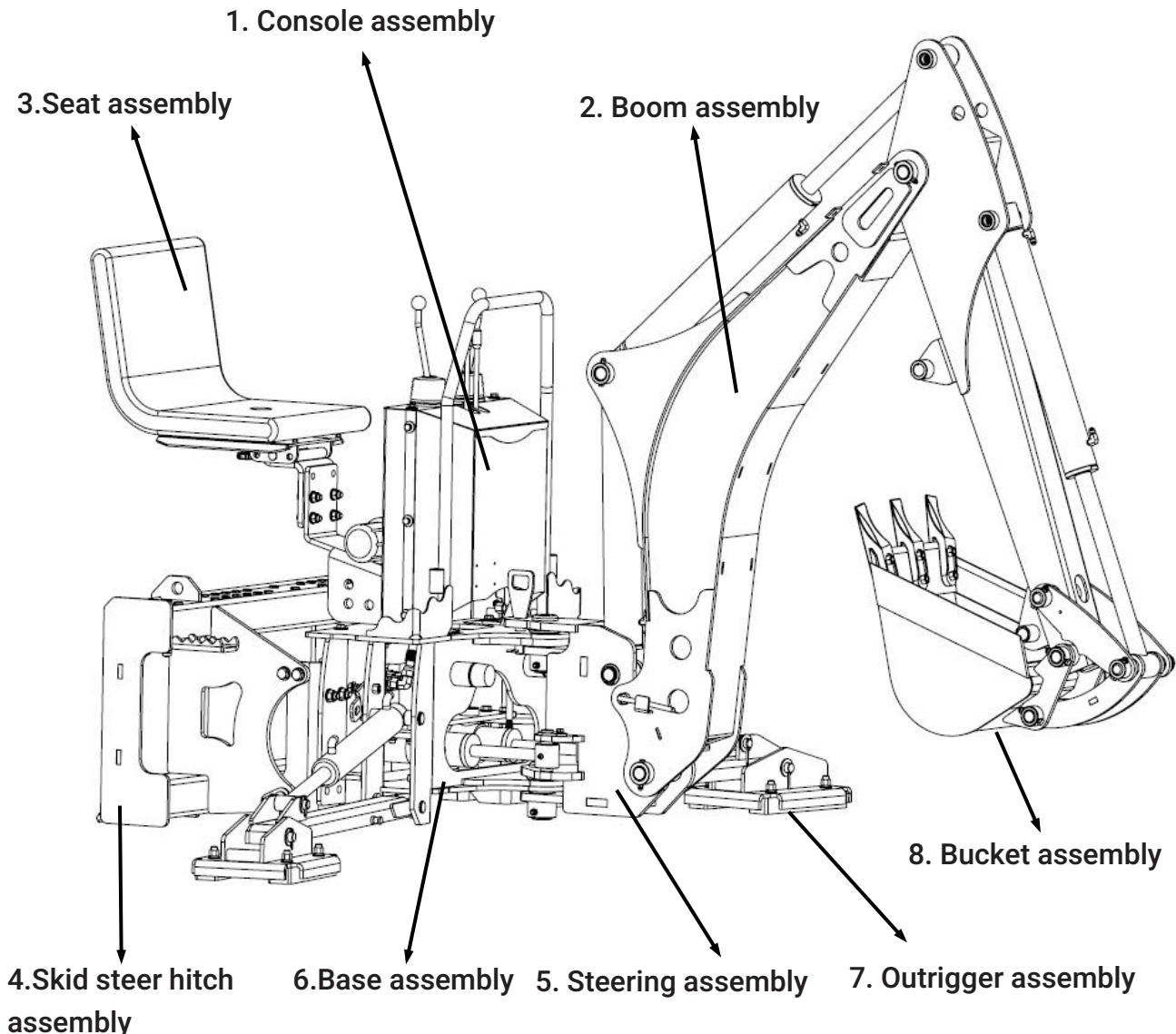

1.Console assembly:

Control machine

2.Boom assembly:

The arm that performs the digging action

3.Seat assembly:

Sit on the seat when operating the machine

4.Skid steer hitch assembly:

Connecting Skid steer loader and Backhoe

5.Steering assembly:

The left and right digging angle of the boom is adjusted by the hydraulic device

6.Base assembly:

Base to support the machine

7.Outrigger assembly:

Legs to adjust machine height

8.Bucket assembly:

Bucket A barrel-shaped member used for digging loose materials such as soil, sand, gravel, and construction waste

PRODUCTS SPECIFICATIONS

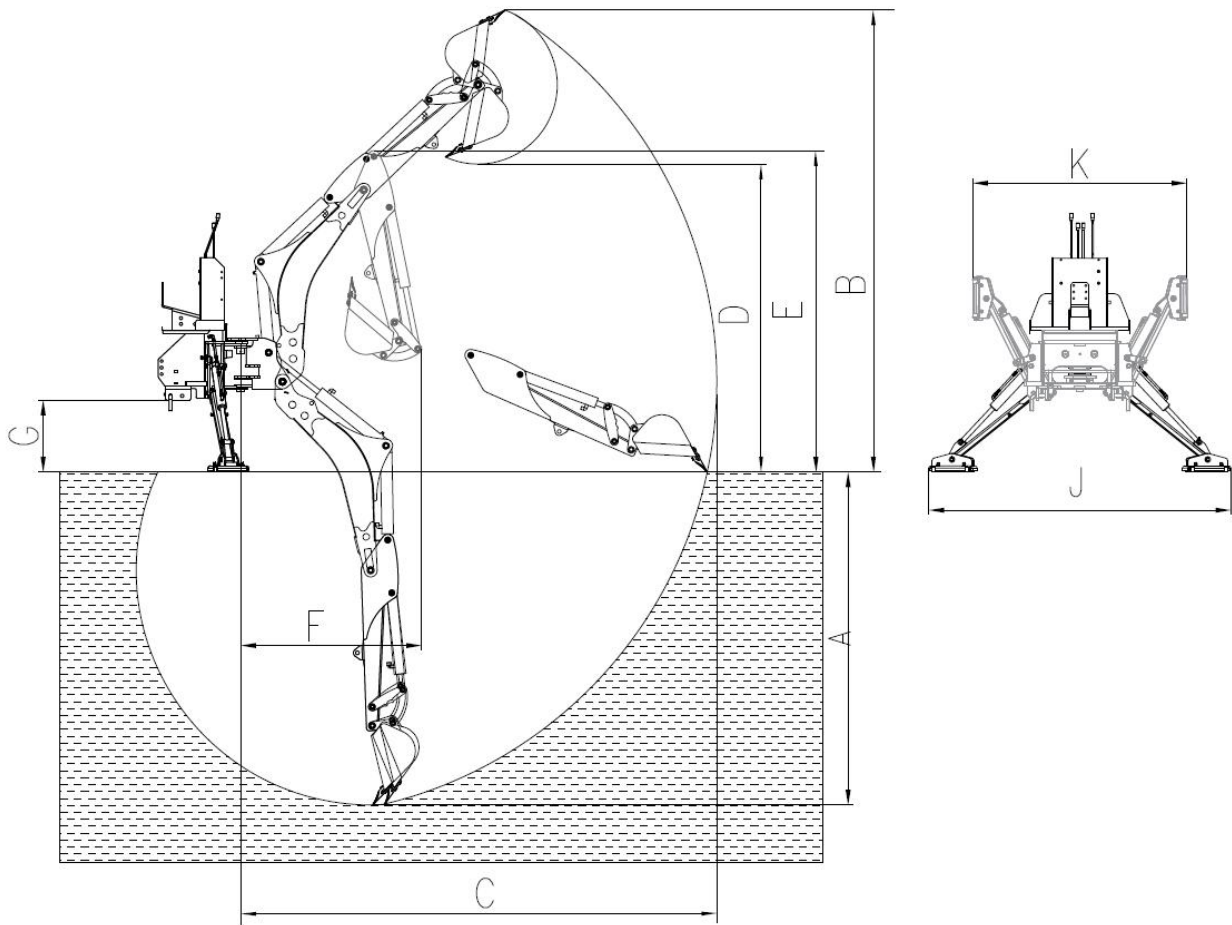

	Specifications	TMG-SBH60
A	Digging Depth(2 ft. flat bottom)	9'
B	Overall Operating Height(fully raised)	123"
C	Reach from Swing POST	129"
D	Loading Height(bucket at 60°rotation)	84"
	Dipper Boom Digging Force	2200 lbs
E	Transport Height(with boom fully retracted)	80"
	Transport Width(with stabilizers up)	58"
F	Transport Length	72"
G	Ground Clearance	10-12"
	Swing Arc	180°
J	Stabilizer Spread (Spread)	89"
K	Stabilizer Spread (Transport)	58"
	Bucket Digging force (lbs)	3300
	Operating Pressure (psi)	2320
	Recommended Skid Steer Loader (HP0)	30-100

UNPACKING & ASSEMBLY

1. After unpacking, check the following components

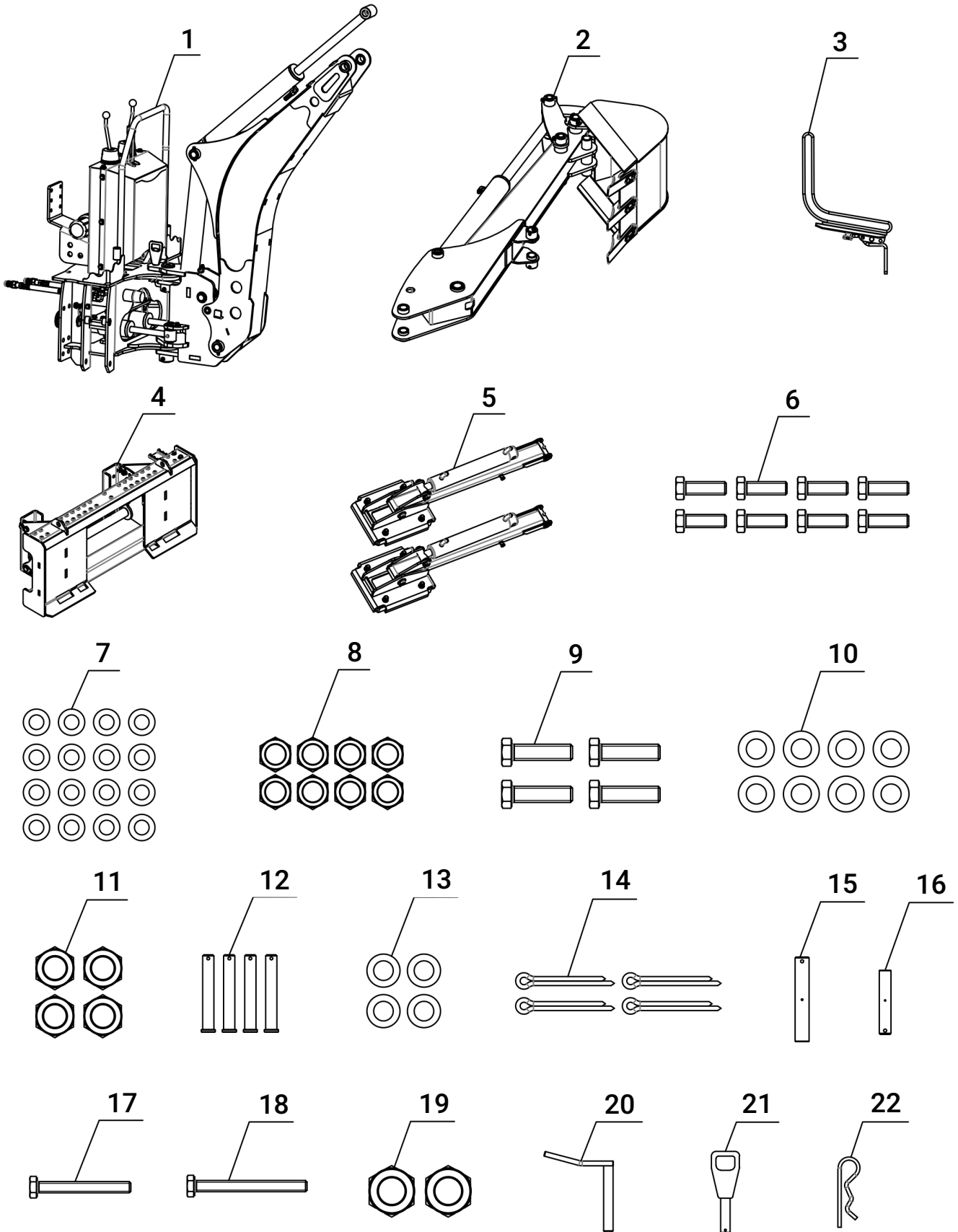

The parts marked with numbers in the figure are the parts that need to be assembled.

*. All numbers are not part numbers in the drawings. For correct part numbers, see explosive diagram.

NO.	DESCRIPTION	QTY	NO.	DESCRIPTION	QTY
1	Base assembly	1	12	Outrigger cylinder pin Ø20x133	4
2	Small boom assembly	1	13	Plain washer Ø20	4
3	Seat components	1	14	Cotter pin 4x32	4
4	Skid steer loader hitch assembly	1	15	Pin shaft Ø30x181	1
5	Stabilizer legs assembly	2	16	Pin shaft Ø25x137	1
6	Fully threaded hex bolts M14x45	8	17	Fully threaded hex bolts M6x50	1
7	Plain washer Ø14	16	18	Fully threaded hex bolts M6x60	1
8	Non-metallic insert hex lock nuts M12	8	19	Non-metallic insert hex lock nuts M6	2
9	Fully threaded hex bolts M12x45	4	20	Pin welding 142	1
10	Plain washer Ø12	8	21	Swivel joint pin	1
11	Non-metallic insert hex lock nuts M12	4	22	R pin	1

* All numbers are not part numbers in the drawings. For correct part numbers, see explosive diagram.

TOOLS FOR INSTALLATION				
NO	DESCRIPTION	SPECIFICATION	CONDITIONS OF USE	QTY
1	Open End Wrench	10/13/18/21/30	M6, M8, M12, M14, M20 bolt fastening	2
2	Air Impact Wrench	1280t	Match the corresponding sleeve instead of the wrench to tighten the bolt	1
3	Hammer			1
4	Torque Wrench	10-220N·m	Measuring torque	1

After the parts are confirmed to be correct and the tools for installation are ready, start the assembly. The specific operation steps are described below.

2. Install the Stabilizer Legs Assembly

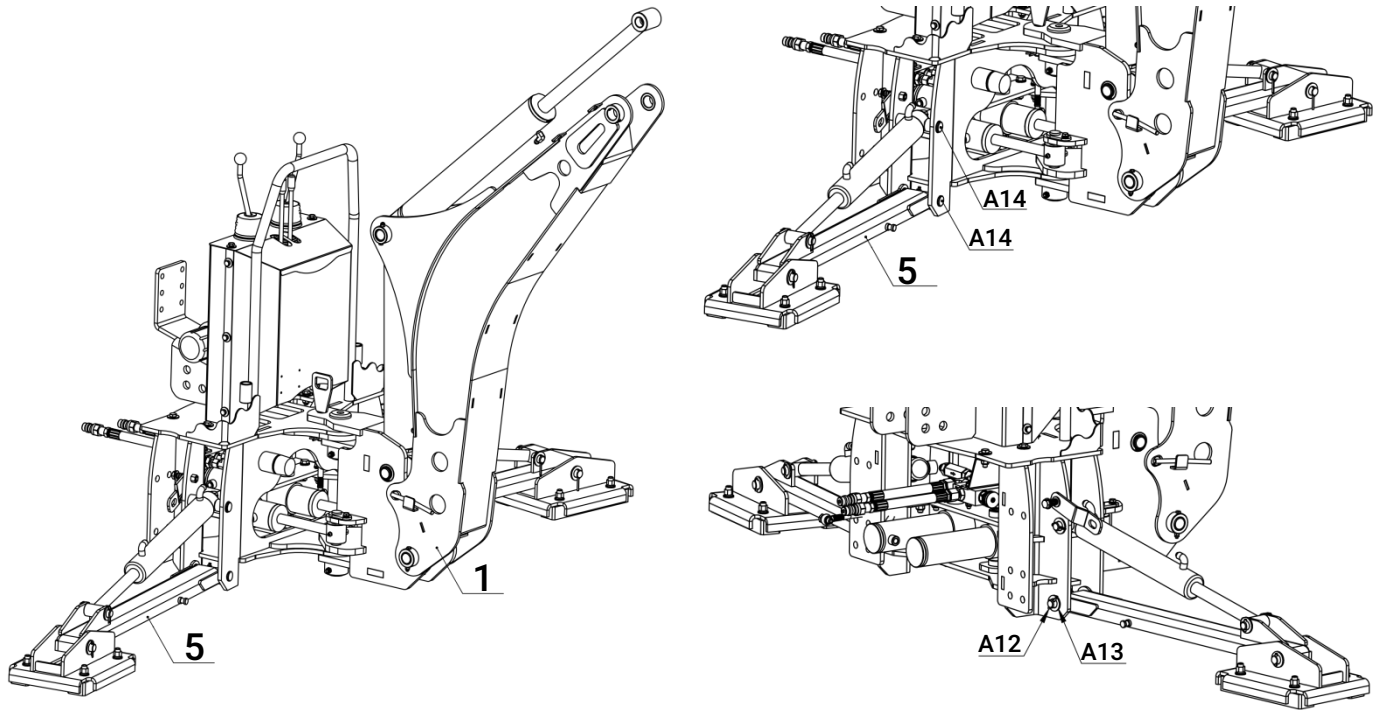

Installation steps:

Place the stabilizer legs assembly (5) at the position shown in the figure above, align it with the installation hole on the base assembly (1), pass through the pin shaft $\varnothing 20 \times 133$ (A14), and install the washer 20 (A13), and the cotter pin 4x32 (A12), the left and right outriggers are installed in the same way.

Importance: All bolts are locked in place without shaking.



WARNING: Once the assembly bolts are not fastened in place, there will be abnormal noises when the machine is working.

PART NO.	DESCRIPTION	QTY
1	Base assembly	1
5	Stabilizer legs assembly	1
A12	Cotter pin 4x32	4
A13	Flat washer $\varnothing 20$	8
A14	Outrigger cylinder pin $\varnothing 20 \times 133$	4

3. Install the skid steer loader hitch assembly

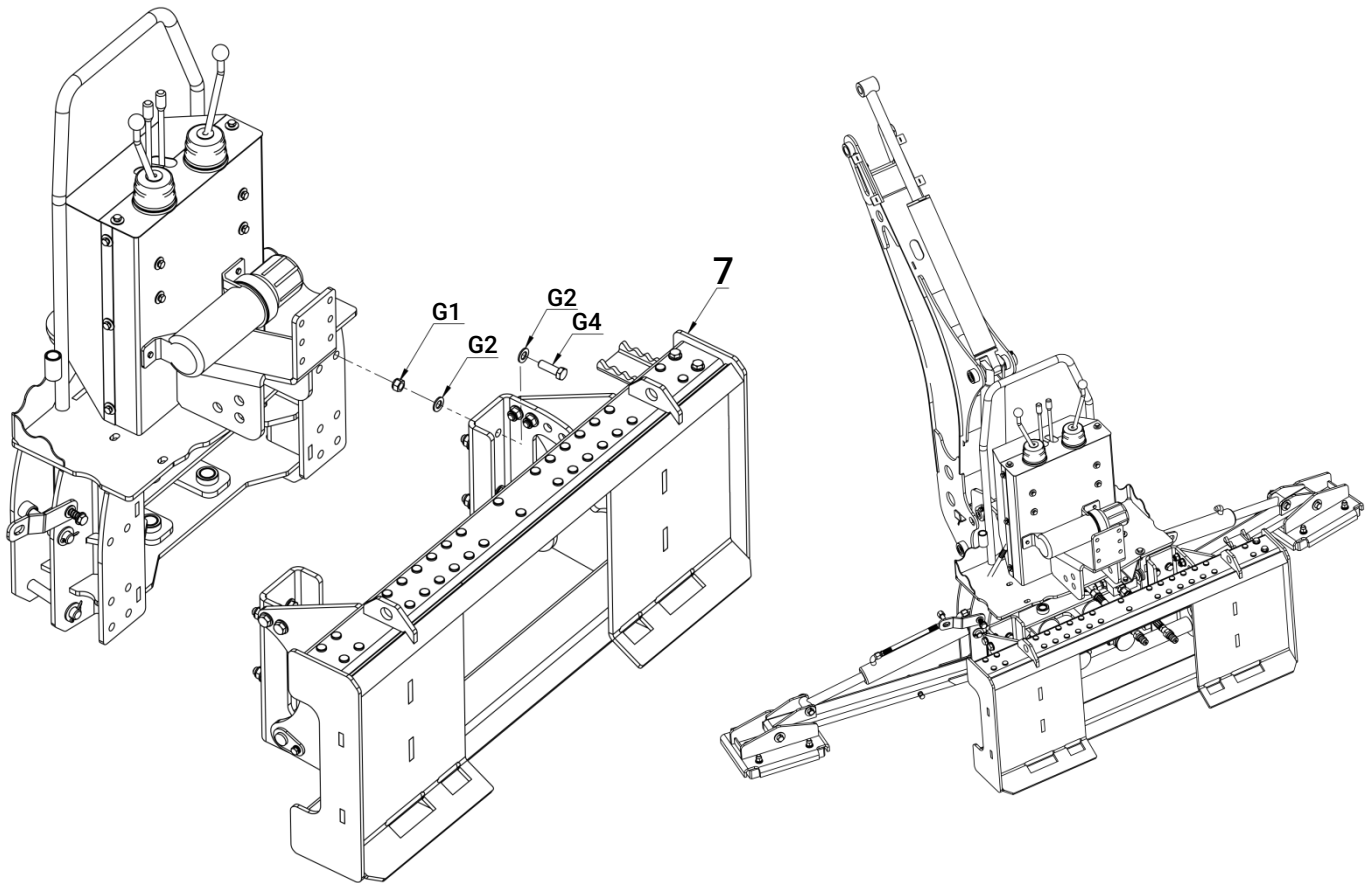

Installation steps:

Align the skid steer loader hitch assembly(7) with the 8 mounting holes on the base assembly , and install the full-threaded hexagon bolt (G4), plain washer (G2), non-metallic insert hexagon lock nut (G1) in sequence and To lock it, add a flat washer (G2) on the nut side and on the bolt side.

Importance: All bolts are locked in place without shaking.



WARNING:Once the assembly bolts are not fastened in place, there will be abnormal noises when the machine is working.

PART NO.	DESCRIPTION	QTY
G1	Non-metallic insert hex lock nuts M14	8
G2	Plain washer Ø20	16
G4	Fully threaded hex bolts M14×45	8
7	Skid steer loader hitch assembly	1

4. Install the seat assembly

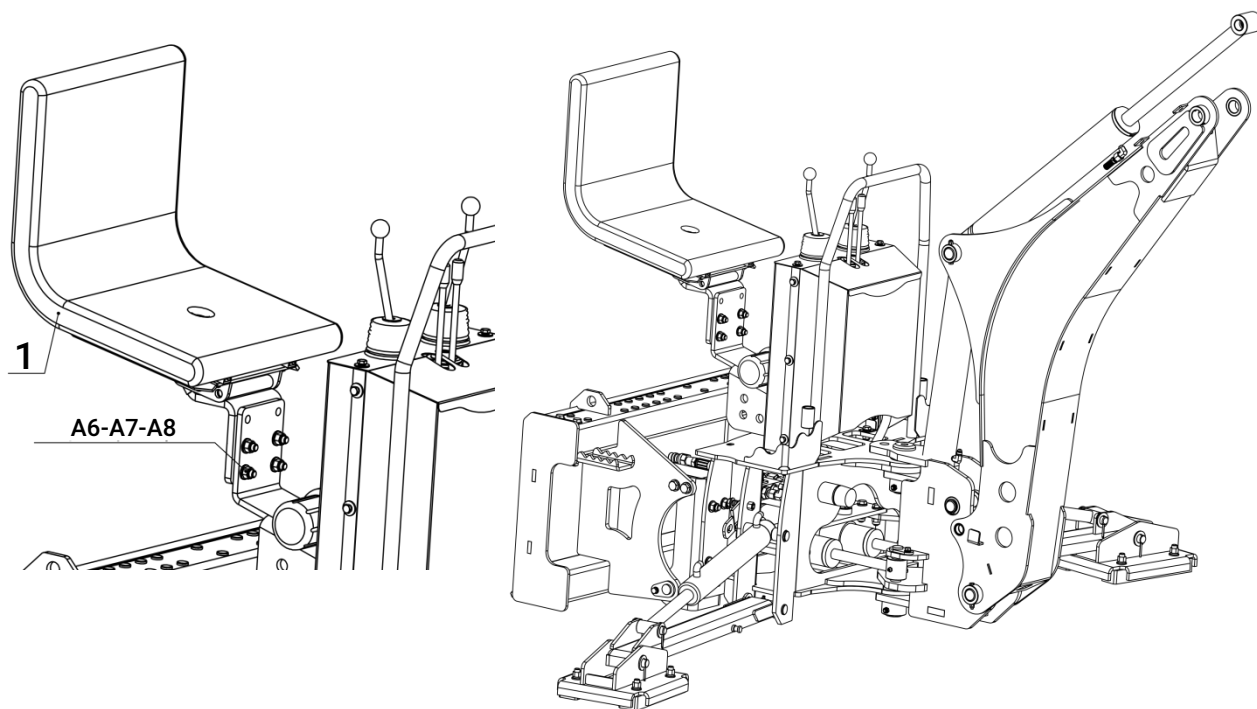

Installation steps:

Align the seat assembly (1) with the 4 mounting holes on the the base assembly, and install the full-threaded hexagon bolt (A6), plain washer (A7), non-metallic insert hexagon lock nut (A8), taking care to tighten the bolts after all components are installed.

Importance: All bolts are locked in place without shaking.



WARNING: Once the assembly bolts are not fastened in place, there will be abnormal noises when the machine is working.

PART NO.	DESCRIPTION	QTY
1	Seat assembly	1
A6	Fully threaded hex bolts M12x45	4
A7	Plain washer Ø12	8
A8	Non-metallic insert hex lock nuts M12	4

5. Install small boom assembly

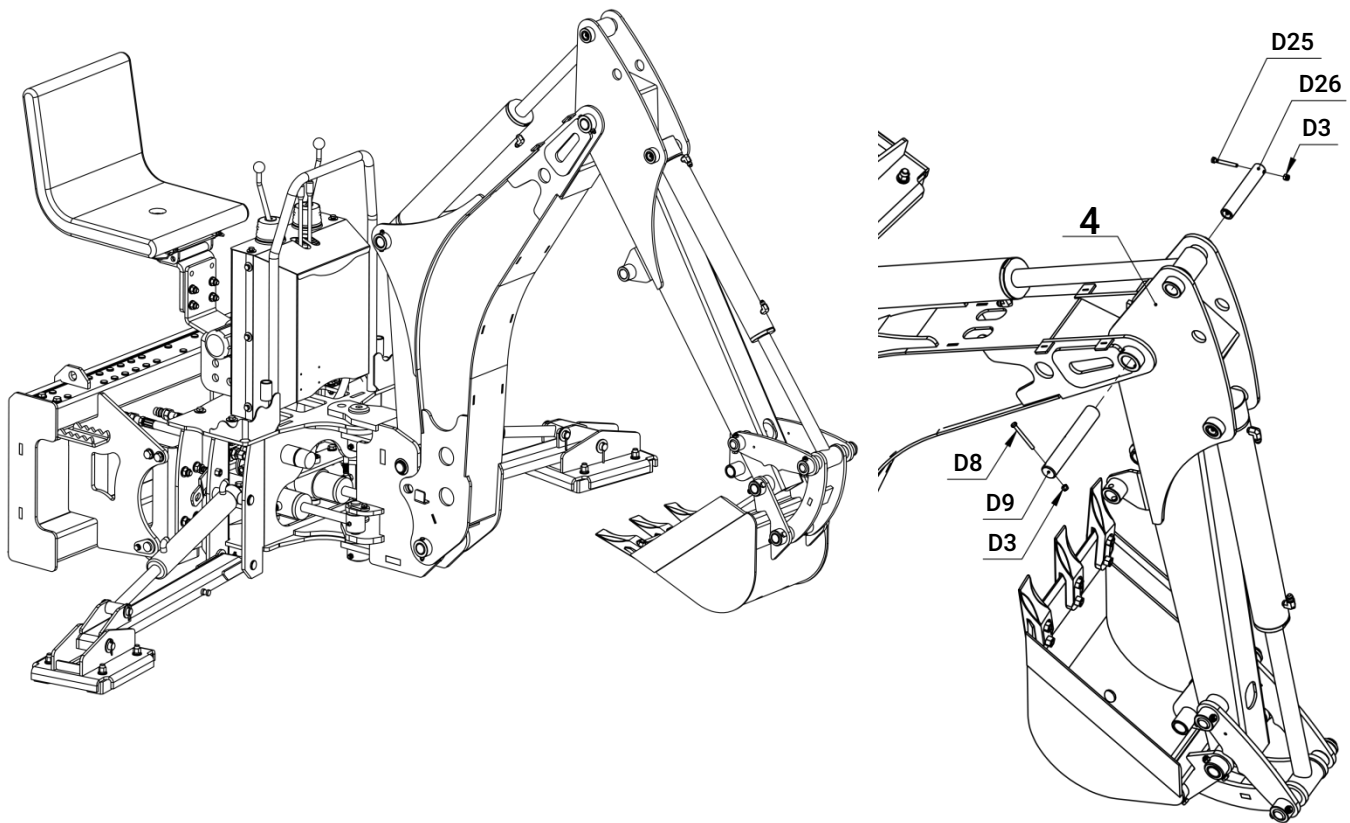

Installation steps:

1. Align the small boom assembly (4) with the mounting hole on the base assembly as shown in the above figure, penetrate the pin shaft $\text{\O}30 \times 181$ (D9), install the bolt $\text{M}6 \times 60$ (D8), and the nut $\text{M}6$ (D3) to lock and fix it.
2. Connect the upper oil cylinder and the small boom assembly in series, penetrate the pin shaft $\text{\O}25 \times 137$ (D26) of the grease fitting, install the bolt $\text{M}6 \times 50$ (D25), and the nut $\text{M}6$ (D3) to lock and fix it.

Importance: All bolts are locked in place without shaking.



WARNING: Once the assembly bolts are not fastened in place, there will be abnormal noises when the machine is working.

PART NO.	DESCRIPTION	QTY
4	Small boom assembly	1
D3	Non-metallic insert hex lock nuts M6	2
D8	Fully threaded hex bolts M6x60	1
D9	Pin shaft $\text{\O}30 \times 181$	1
D25	Fully threaded hex bolts M6x50	1
D26	Pin shaft $\text{\O}25 \times 137$	1

6. Install and connection hydraulic tubing

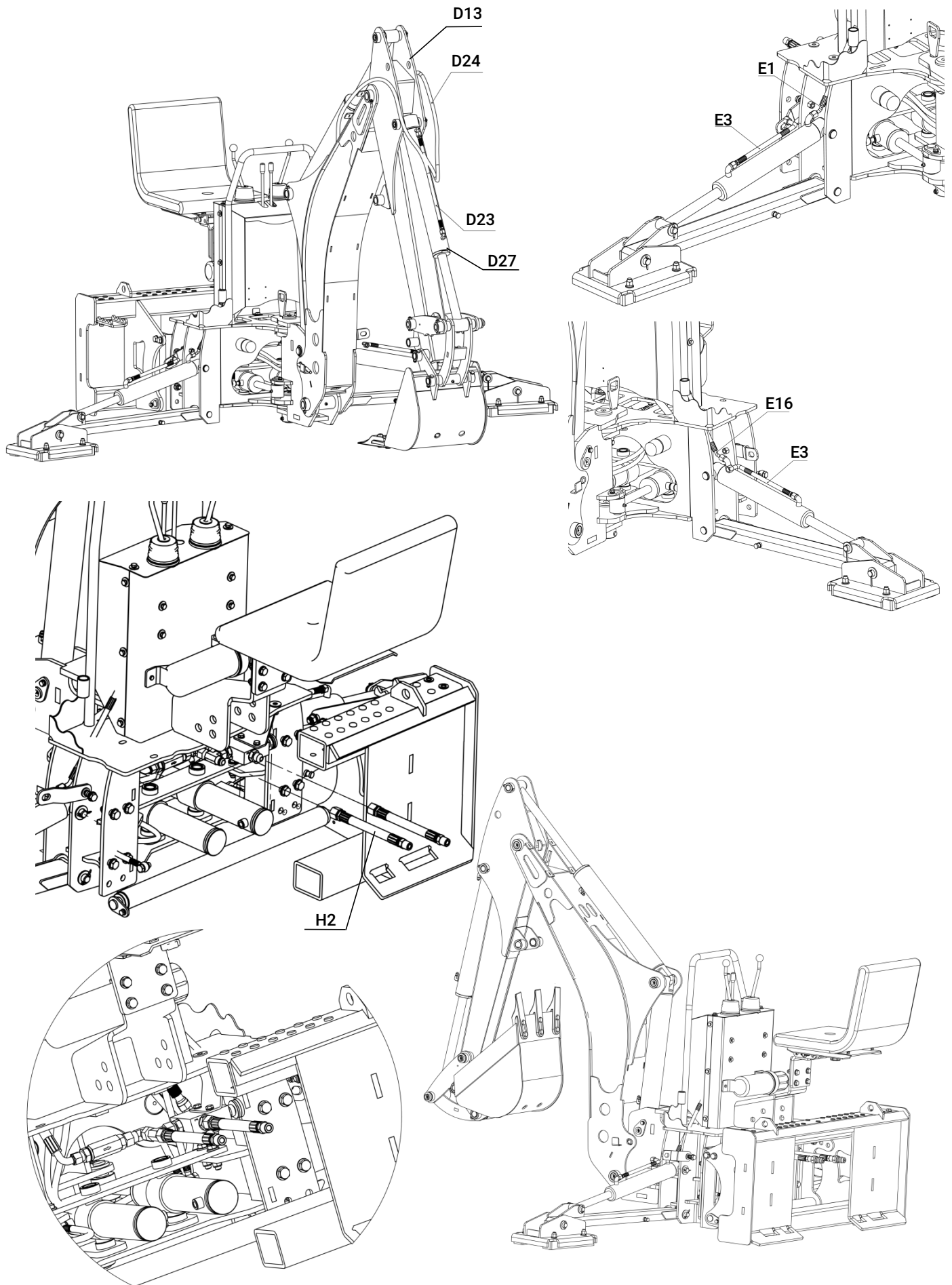

Connection steps:

As shown in the figure above, there are still 6 oil pipes that need to be connected. One side of these 6 oil pipes has been connected to the multi-way valve, and the other side needs to be connected to the oil cylinder. The product number is marked on the oil pipe joint. The oil pipe is connected to the corresponding oil cylinder joint according to the product number shown in the figure above.

1. Bucket cylinder oil outlet pipe (D23) is connected with the outlet nozzle of the bucket cylinder (D27) on the small boom assembly (D13). Bucket cylinder oil inlet pipe (D24) is connected with the inlet nozzle of the bucket cylinder (D27) on the small boom assembly (D13).
2. Right outrigger cylinder oil inlet pipe (E1) and oil inlet pipe of left outrigger oil cylinder (E16) are connected with the inlet nozzle of the outrigger cylinder (E2) on the strut weldment (E5). Outrigger cylinder oil outlet pipes (E3) are connected with the outlet nozzle of the outrigger cylinder (E2) on the strut weldment (E5).

Installation steps:

There are two hydraulic tubing installations, one end connected to the flow control valve, the other end connected to the hydraulic output of the tractor when in using. Now connect one end of the flow control valve.

1. Install one hydraulic tubing to tee joint (H19) connector of flow control valve body (H6).
2. Install other hydraulic tubing to pump suction fitting (H3) connector of flow control valve body (H6).



WARNING: All tubing joints must be tightened, otherwise there will be oil leakage, and the machine operation cannot achieve the effect.

PART NO.	DESCRIPTION	QTY
H2	Flow control valve connecting oil pipe 1/2"(ID)X78", 1/2 NPT fitting	2

CONNECTING SKID STEER LOADER

1. About the backhoe attachment

The backhoe attachment is intended for use in earth digging. The primary use of the backhoe attachment includes digging, land clearing, landscaping, demolition, construction, and grounds maintenance. Use of this equipment in any other manner is considered to be contrary to the intended use of the attachment.

2. Attaching the Backhoe to the Skid Steer Loader

NOTE: Before attempting to attach the backhoe to the skid steer loader, verify that all hydraulic couplings are compatible.



WARNING – Improper attachment to the skid steer loader may cause personal injury.



CAUTION – All hydraulic connections must be clean and free of debris before making any connection.

1. Place the backhoe attachment on a level surface.
 2. Position and align the skid steer loader to the rear of the attachment, within proximity of the front of the skid steer loader.
 3. Insert and connect the skid steer loader into the attachment.
 - Slowly position your skid steer loader towards the rear of the backhoe.
 - Slowly insert the top edge of your quick attach into the top rail of the backhoe from underneath.
 - As the top of the quick attach aligns into the backhoe, slowly roll your quick attach back towards the machine until the entire quick attach locks into the mount. Using either your power attach or manual levers, lock the backhoe in place.
 4. Connect the hydraulic lines from the attachment to the skid steer loader.
(See page 46 of the manual for the specific connection method)
 5. Close latches (or other locking mechanism) to secure the attachment to the skid steer loader.
 6. Using the skid steer loader, raise the attachment and move the attachment to ensure hydraulic lines are clear of air and operate properly.
-  **CAUTION** – Hydraulics should operate in an even and smooth manner. Hydraulic movement that is not even and smooth may indicate that air is in the hydraulic lines.
7. Lower the attachment to ground level.
 8. Inspect that the attachment is mounted properly and securely. If the attachment does not meet this requirement, follow the instructions to remove the backhoe and re-attach using the instructions above.

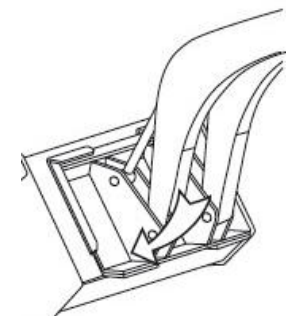
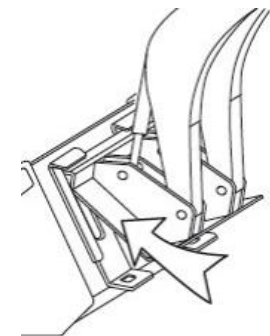
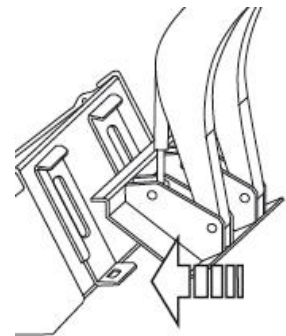

3. Removing the Backhoe from the Carrier Machine



WARNING – Improper disconnection may result person injury or damage to the attachment and carrier machine.



CAUTION – All hydraulic connections must be clean and free of debris before disconnection.

1. Using the carrier machine, lower the attachment to the ground.
2. To prevent contamination, remove any dirt and debris from the couplings. Disconnect the hydraulic connection between the attachment and the carrier machine.

NOTE: Hydraulic connections must be disconnected before disengaging latches to prevent damage to the carrier machine or the attachment.

3. Disengage the carrier machine latches (or other locking mechanisms) from the attachment.
4. Move the carrier machine from the attachment.

CHECK BEFORE OPERATING

1. Check before operating

Before operating the machine, check the following:

1. Check that the backhoe is properly attached to the power unit. Be sure retainers are used on the mounting pins and mounting hardware is tightened to their specified torque.
2. Check that hoses and pivot points are free of any debris or entangled material.
3. Check the machine has been lubricated following the schedule outlined in the Maintenance section.
4. Check that all boom assembly pivot points move freely.
5. Check that stabilizers move freely.
6. Check that hydraulic hoses are not rubbing anywhere, pinched or crimped.
7. Check for hydraulic leaks. Tighten connections or replace components to stop leaks.
8. Check and ensure that all covers, guards and shields are in place, secured, and can function as designed.
9. Check and tighten all fasteners. Make sure the equipment is in good condition.
10. Check that appropriate equipment for personal protection is available and being used.
11. Check that jewelry, loose-fitting clothing are not worn. Make sure long hair is tied back.

2. Before startup

Each operator must be trained in the proper operating procedures prior to operating the machine. The new machine or machine long unused, you must first idling operation.

- Review location of the controls, their function, and movement direction when activated.
- Follow the Pre-Operation Check.
- Set up the machine correctly.

3. Remove swivel joint pin and pin welding 142

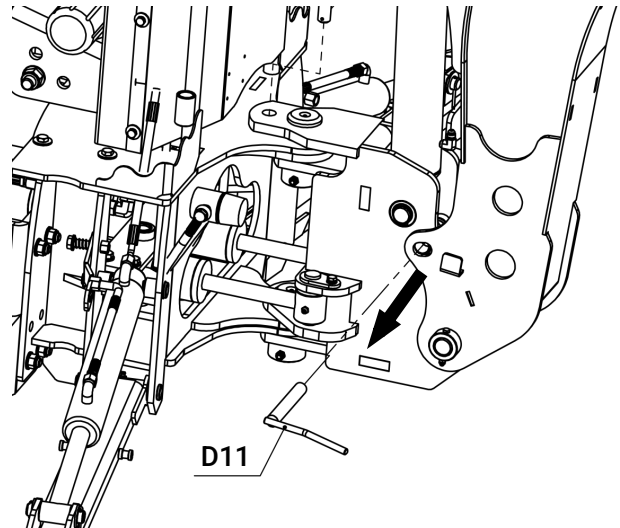
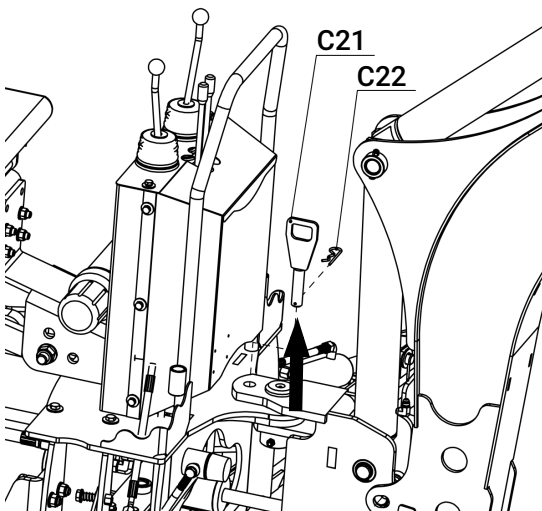

Keep the machine stable during transportation, so install limit pins for the base assembly and big boom assembly to hold. So you need to remove the limit pin on the arm and base before use

1. Remove R ping (C22) and pull out swivel joint pin (C21) on the base assembly.
2. Pull out of pin welding 142 (D11) on the big boom assembly.



DANGER

When the machine is use finished, reinstall swivel joint pin (C21) and pin welding 142 (D11) immediately. If not installed, the boom assembly will swing from side to side and tip over, which will cause heavy property losses and casualties

LUBRICATION POINTS SUMMARY

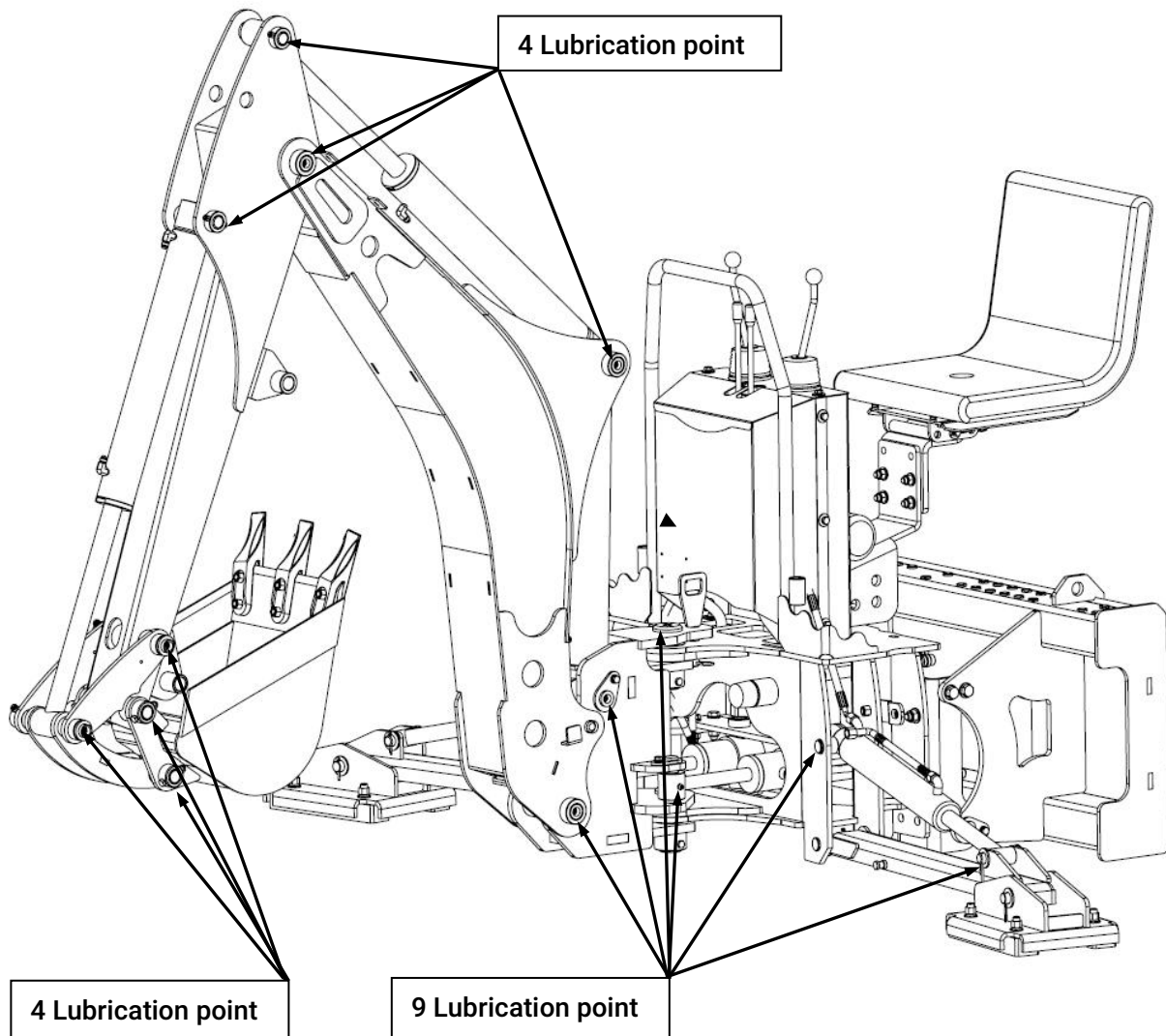

- Designated parts have been oiled, please confirm before use.

CONTROLS

1. Backhoe control

Backhoe control configuration is SAE control mode. All controls are mounted on top of the base, when the operator sits. When in the seat, it is easy to maneuver.

All operators should read this section of the manual and be familiar with all the positions and functions of its controls before starting operation.



WARNING!

Do not operate the machine until you are thoroughly familiar with the position and function of the various controls. Read the operator's manual thoroughly. Your safety is involved!

Backhoe control chart

1. Lifting and swinging of main arm
2. Left outrigger stabilizer
3. Right outrigger stabilizer
4. Stick and bucket controls

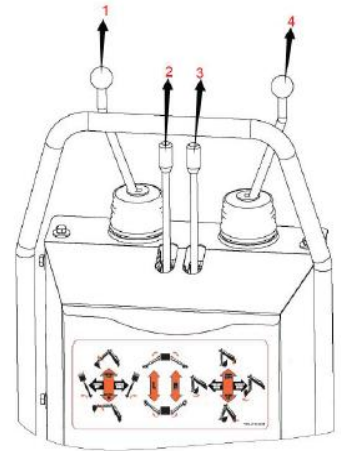

2. Boom, up and down

- Push the left hand control lever forward to lower the main boom
- Pull back the console and raise the boom
- Push the lever all the way forward until it stops

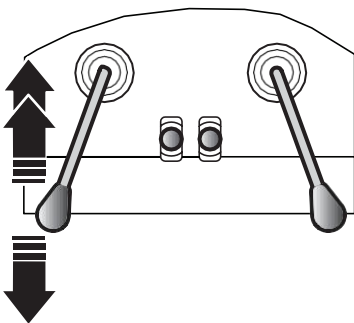

3. Swing left and right

- Move the left lever to the left to swing the boom to the left.
- Move the lever to the right to swing the boom to the right.

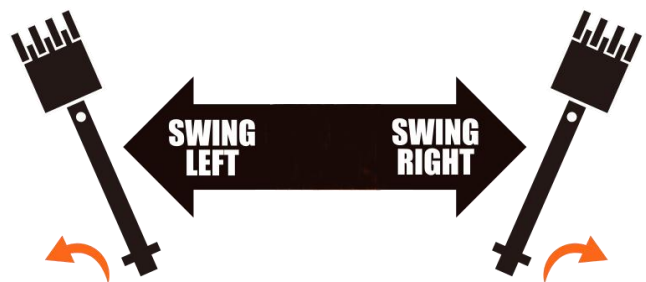
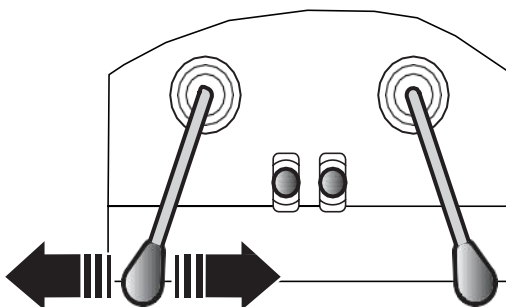

4. Outrigger stabilizer, upward, downward

- Push the second lever forward from the left to lower the left stabilizer.
- Pull back the lever to raise the stabilizer.

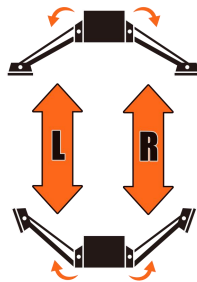
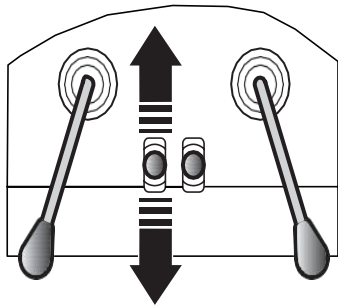

- Push the lever a second time forward from the right to lower the right stabilizer.
- Pull back the lever, raise the stabilizer

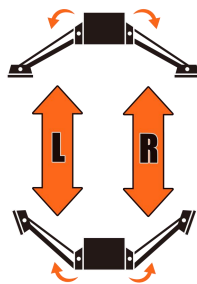
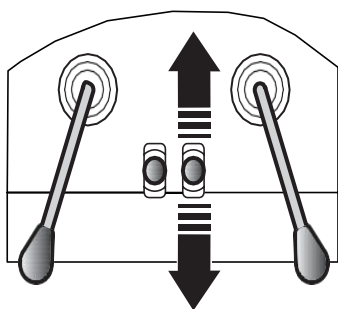

5. Stick operation, away-closer

- Push the extreme right control stick forward to extend the stick.
- Pull back on the lever to pull in the stick.

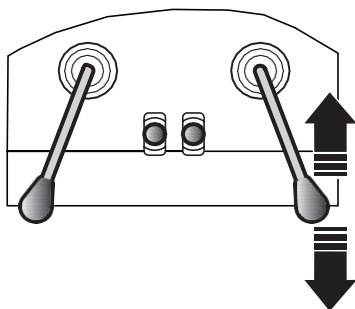

6. Bucket, roll in - roll out

- Move the right hand control lever to the left to reel the barrel in.
- Move the lever to the right to dump the bucket.

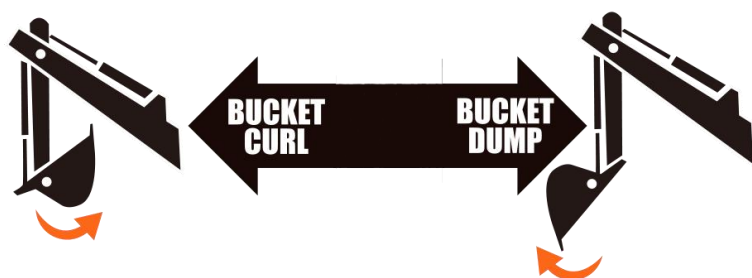
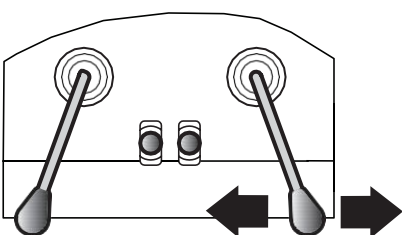

OPERATING ESSENTIALS

1. Machine Set-up

1. Position the machine at the work site and set the park brake.
2. Set the stabilizers down to remove some of the weight from the tires.
3. On a tractor, lower the front bucket and set the stabilizers to remove some weight off the tires. Keep the tires in contact with the ground.

Raising the wheels off the ground reduces stability and digging depth and causes unnecessary stress on the stabilizers and backhoe.

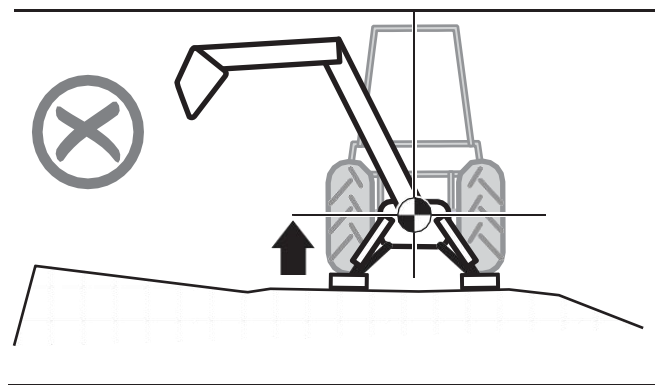

Center of gravity too high

The wheels must remain in contact with the ground as this provides the widest stabilizer stance and the lowest centre of gravity.

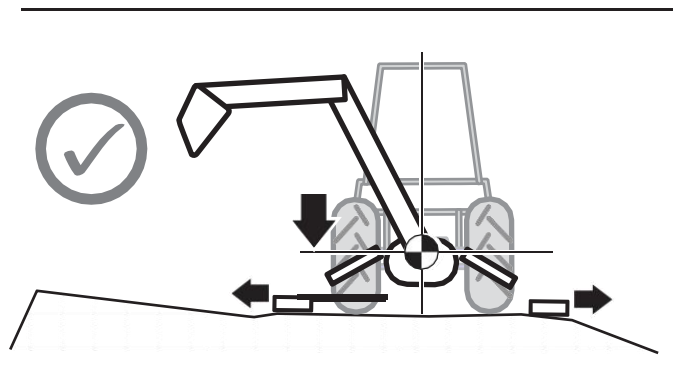

Stabilizers lowered. Tires in contact with the ground.

4. Remove the main boom swing lock pin.

2. Machine Break-in

Although there are no operational restrictions on the backhoe when used for the first time, it is recommended that the following mechanical items be checked:

After operating for 1/2 hour–

1. Check all nuts, bolts and other fasteners. Tighten to torque specification.
2. Check the condition of all hydraulic lines, hoses and fittings. Replace any that are damaged. Re-route those that are rubbing, pinched or crimped. Tighten any fitting that is leaking.

3. Check the condition of the teeth on the bucket. Replace any that are bent, chipped, broken or missing.
4. Check the oil level in the hydraulic reservoir if so equipped. Add as required.
5. Check the boom, dipper and bucket pivot pins. Be sure all are anchored securely in position.
6. Check the stabilizer pins are in place.
7. Lubricate all grease points.
8. After operating the machine for 5 and 10-hour periods, repeat steps 1–7.

3. Working on Slopes

Use extreme caution when excavating on a slope. Always lower the stabilizers and bucket. If the ground is soft, use pads or timbers under the stabilizers.

Do not attempt excavating on a slope while the backhoe is positioned on an angle. The danger of a tip over is greater as the center of gravity moves to the downside of the backhoe.

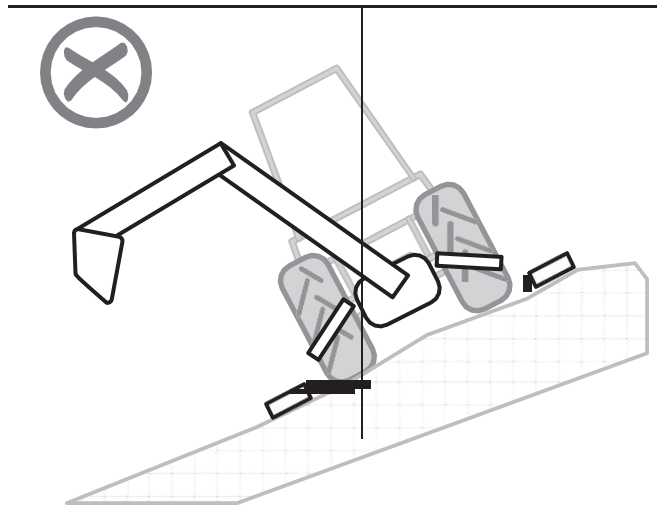

Tip Over Hazard

Backhoes are designed to work with the frame horizontal. The stabilizers are used to level the machine.

If this is not the case, planks or blocking can be placed under the stabilizers to level the machine. All four wheels must be touching the ground.

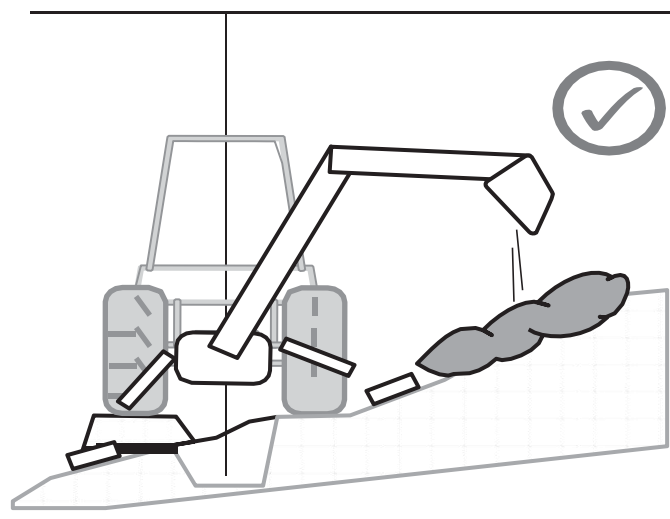

Swing boom up slope when possible

Refrain from swinging the boom to the downside of the hill. Danger of tip over is much greater since the center of gravity moves further to the downside of the backhoe as swing increases.

For the greatest stability, always swing the boom up slope. If swinging down slope must be done, do so with extreme caution. Swing only as far as necessary to dump the bucket.

4. Excavating

Always lower the stabilizers and front loader bucket. If the ground is soft, use pads or place wood blocking under the stabilizers.

Do not undercut the stabilizers. Doing so could cause the stabilizer to give way and the backhoe could tip over into the excavation.

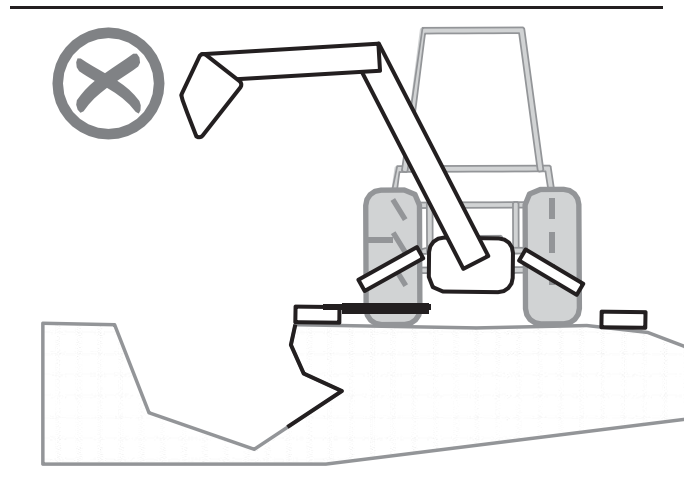

Do not undercut the stabilizers

Always have an underground utility locating/marking service survey the area before digging. Be aware of overhead hazards.

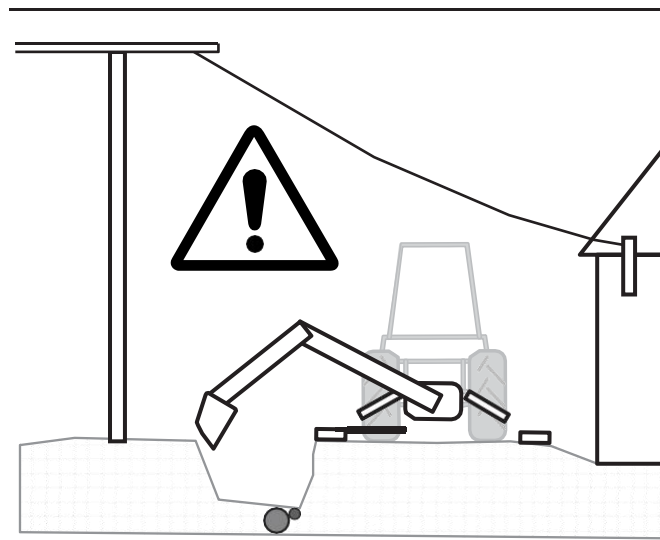

Be aware of underground and overhead hazards

5. Using the backhoe for lifting or moving a load

Always lower the stabilizers and front loader bucket.

Always position the machine so the backhoe is lifting in line with the frame.

When moving while carrying a load, travel slowly and be aware along the travel path.

Use a tag line to keep the load from swinging. Refrain from swinging the boom when transporting a load. An uncontrolled swinging load could cause serious injury or death.

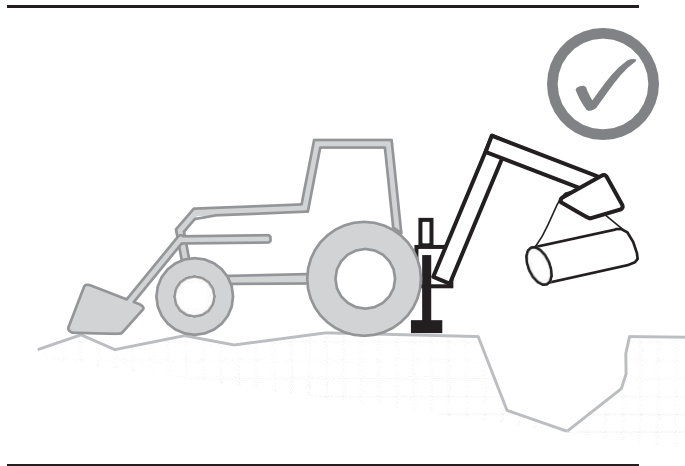

Lower stabilizers and front bucket before lifting a load

6. Digging with the Backhoe

1. Increase engine speed to mid-range or rated PTO rpm.
2. Engage hydraulic circuit or place hydraulic control in detent. If you have the optional PTO pump, engage PTO (refer to tractor manual).
3. Remove the boom swing and boom lock pins.
4. Swing the driver's seat around or take position in the operator's seat. Use the controls to begin digging.
5. Swing the dipper out and adjust bucket so the teeth can dig into the ground at a slight angle. Lower the boom down to set teeth into the ground. Keep the heel of the bucket up higher than the teeth.
6. Retract the dipper to pull the bucket through the soil as it fills. Slowly close the bucket at the same time. If necessary, apply a downward pressure on the boom to increase digging force.

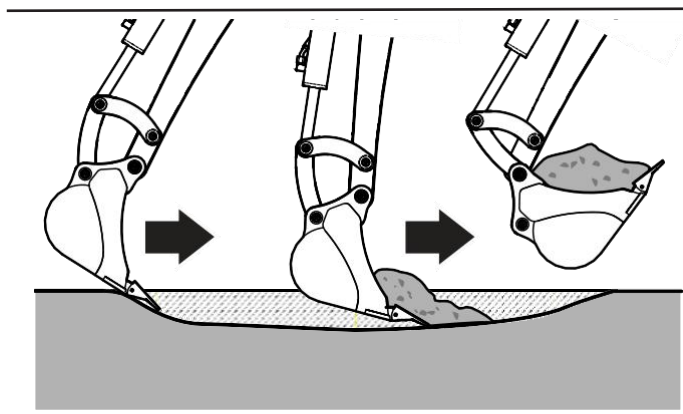

Digging with the Dipper Boom

7. Curl the bucket up when full. Raise the boom and at the same time, move the dipper out a little to keep soil from building up under the machine.

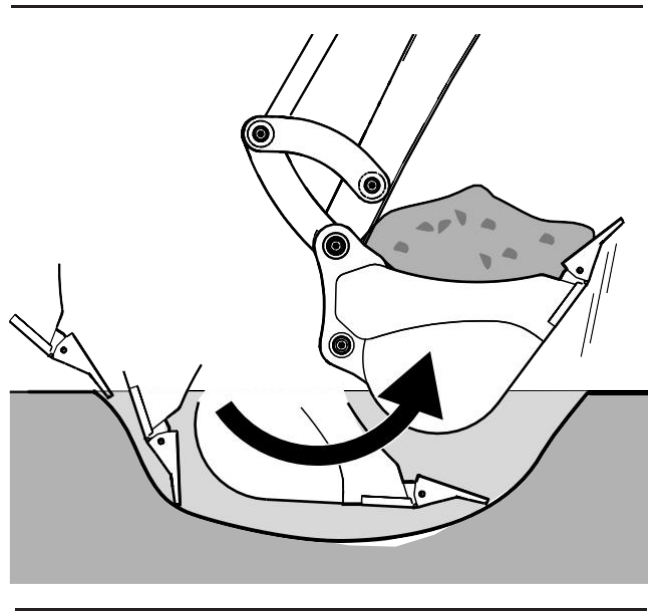

Digging with Bucket

8. Swing away from your excavation and dump the bucket. Start dumping as the bucket approaches the pile. Do not waste time by dumping too far from the excavation. Swing back to start the next dig.
9. Deepen the dig with each pass.

IMPORTANT! Do not use the side of the excavation to stop the bucket. The backhoe could be damaged.

OPERATING FINISH

1. Stopping and Parking the Machine

Park the machine on dry, level ground.

1. Lower the boom to the ground.
2. Set the parking brake.
3. Allow the engine to idle for 5 minutes to cool.
4. Turn the hydraulic circuit OFF.
5. Turn ignition to OFF and remove the key.
6. Turn battery disconnect switch OFF (if equipped).
7. Dismount the machine using three points of contact. Step only on non-slip surfaces.

2. Reinstall swivel joint pin and pin welding 142

When the machine is not in use, insert swivel joint pin (C21) and fixed R ping (C22) to limit the base assembly and boom assembly.

Then insert pin welding 142 (D11) to restrict the base assembly and boom assembly.

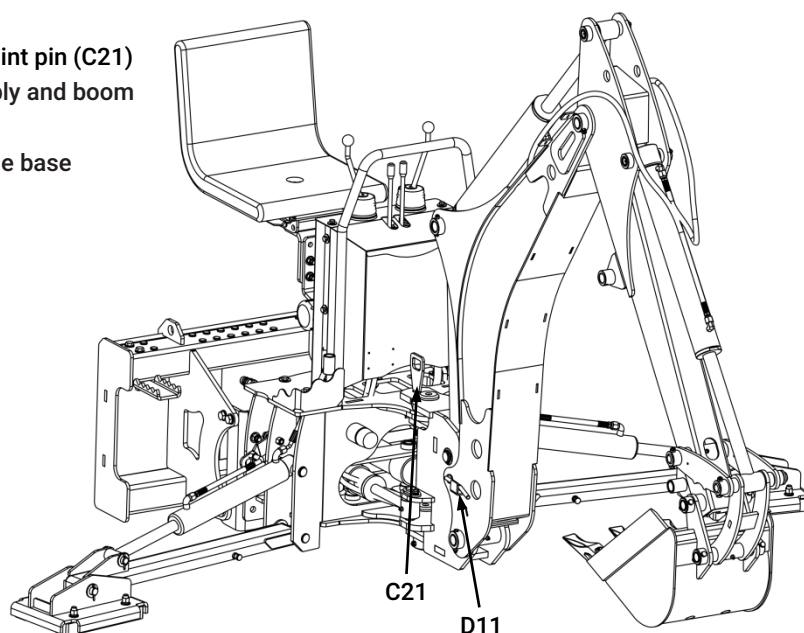

3. Storage

After the season's use or and the backhoe is not going to be used for a period of time, disconnect it from the machine and place it away in storage. Repair or replace any worn or damaged components to prevent any unnecessary down time at next use.

To ensure a long, trouble-free life for your backhoe, follow these steps:

1. Thoroughly wash the machine using a pressure washer to remove all dirt, mud, and debris.
2. Inspect the bucket, dipper, and boom for damage or entangled material. Repair or replace damaged parts. Remove all entangled material.
3. Check the oil in the optional reservoir (if so equipped). Add as required.
4. Lubricate all grease fittings. Make sure all grease cavities have been filled with grease to remove any water residue from washing.
5. Touch up all paint nicks and scratches to prevent rusting.
6. Store the machine in an area away from human activity. Select an area that is dry, level and free of debris.
7. Place blocks or planks under the base and bucket.
8. Unhook from the skid steer loader.
9. Put plastic caps on hose ends and stow hoses in storage brackets to keep them off the ground.
10. Apply a coat of heavy grease to exposed cylinder rams to prevent rusting.
11. If the machine cannot be placed inside, cover with a waterproof tarp. Tie securely in place.
12. Do not allow children to play on or around the stored machine.

MAINTENANCE SCHEDULE

Perform maintenance procedures at time shown or hour interval, whichever comes first.

Inspection unit list	Inspection time
Remove any entangled material from backhoe.	Before/Post the job
Check that all fasteners are tight.	Before/Post the job
Check the condition of all hydraulic lines, hoses, and fittings. Replace any that are damaged. Re-route those that are rubbing, pinched, or crimped. Tighten any fitting that is leaking. Ensure fittings are clean and free of dirt.	Before/Post the job
Grease Backhoe	Every 8 hours of operation or daily
Check condition of bucket teeth	Every 50 hours of operation or weekly
Clean machine—remove any entangled material or debris build-up.	Every 100 hours of operation or annually

TROUBLESHOOTING

PROBLEM	PROBABLE CAUSE	SOLUTION
Cylinder rods do not move or move slowly.	No pressurized hydraulic oil.	Oil filter plugged. Change filter.
		Low hydraulic oil level. Add oil to reservoir.
	Pressure and return hoses to backhoe are reversed.	Change hose connections.
	Not enough oil flow.	Flow control set too low. Adjust for more flow.
	Stuck / damaged / mismatched couplers.	Clean or replace couplers. Make sure mating couplers are same style.
	Check valve stuck.	Clean or replace.
	Engine speed too slow.	Increase engine speed to correct rpm.
Cylinder movements jerky.	Hydraulic system leak. Air in hydraulic system.	Tighten all hydraulic connections. Cycle cylinders to remove air.
Control handle does not go to neutral when released.	Return springs collapsed.	Check and replace if required.
	Control valve may be damaged.	Tighten or replace if damaged.
Hydraulic hose leaking.	Hose worn or damaged.	Replace hose. Check hose routing to avoid chafing or rubbing.
	Loose hose connection. Adapters or hose ends damaged.	Tighten or replace if damaged.
Cylinder leaking oil.	Seals worn.	Call technician. Seal replacement may be required.
Hydraulic system behaving erratically.	Mismatched control valve. Valve type must be same as tractor hydraulic circuit (open or closed center).	Determine if hydraulic system on tractor is open or closed center. Make sure is same.
Boom drifts down.	Seals leaking (bypassing).	Replace seals.
	Counterbalance valve defective.	Repair or replace.
Boom does not swing or swings slowly.	Boom swing lock pin in place.	Remove boom lock pins before starting work.
	No oil pressure.	Oil filter plugged. Change filter.
		Low hydraulic oil level. Add oil to reservoir.
	Oil flow too low.	Flow control set too low. Adjust control to increase flow.
Engine speed too low.	Increase speed to correct rpm.	

EXPLODED VIEW & PARTS LIST

1. Classification of major components

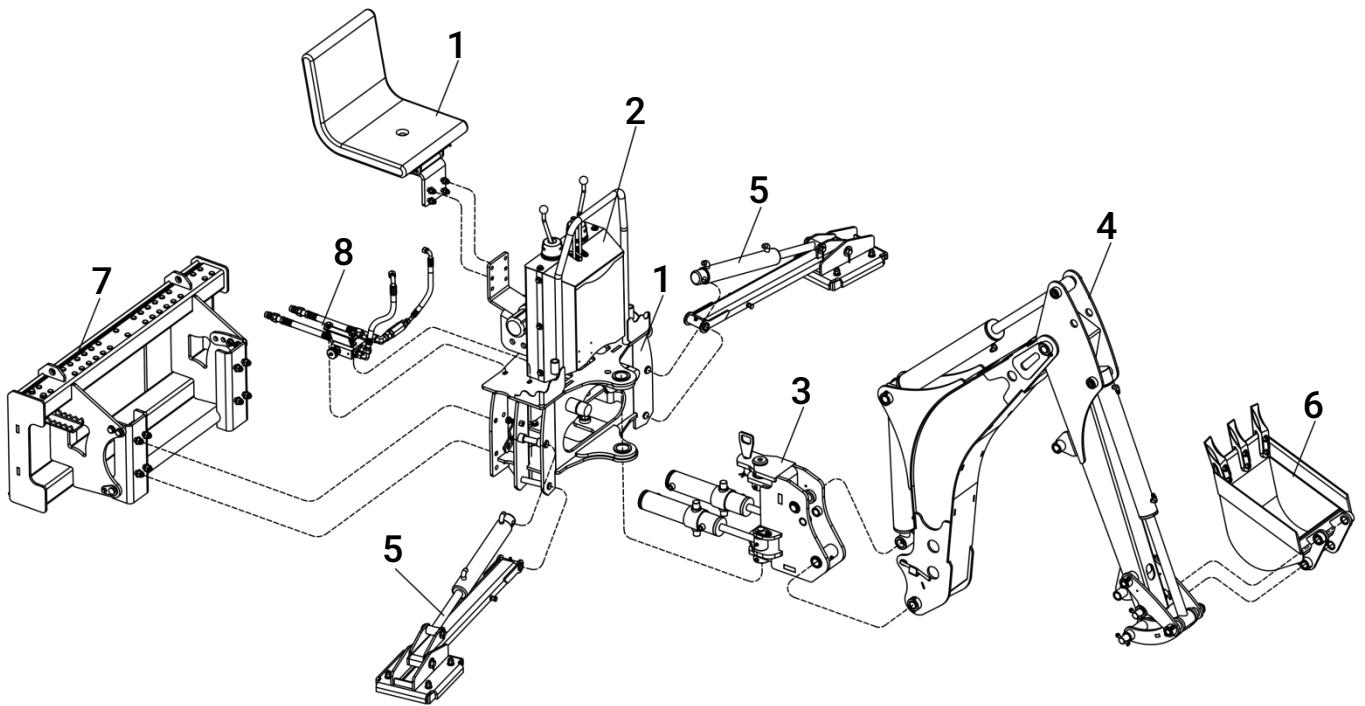

PARTS LIST

PART NO.	DESCRIPTION	QTY	PART NO.	DESCRIPTION	QTY
1	Base and seat assembly	1	5	Stabilizer legs assembly	2
2	Console assembly	4	6	Bucket parts	1
3	Boom rotation assembly	8	7	Skid steer loader hitch assembly	1
4	Boom assembly	4	8	Flow control valve assembly	1

3. Console assembly

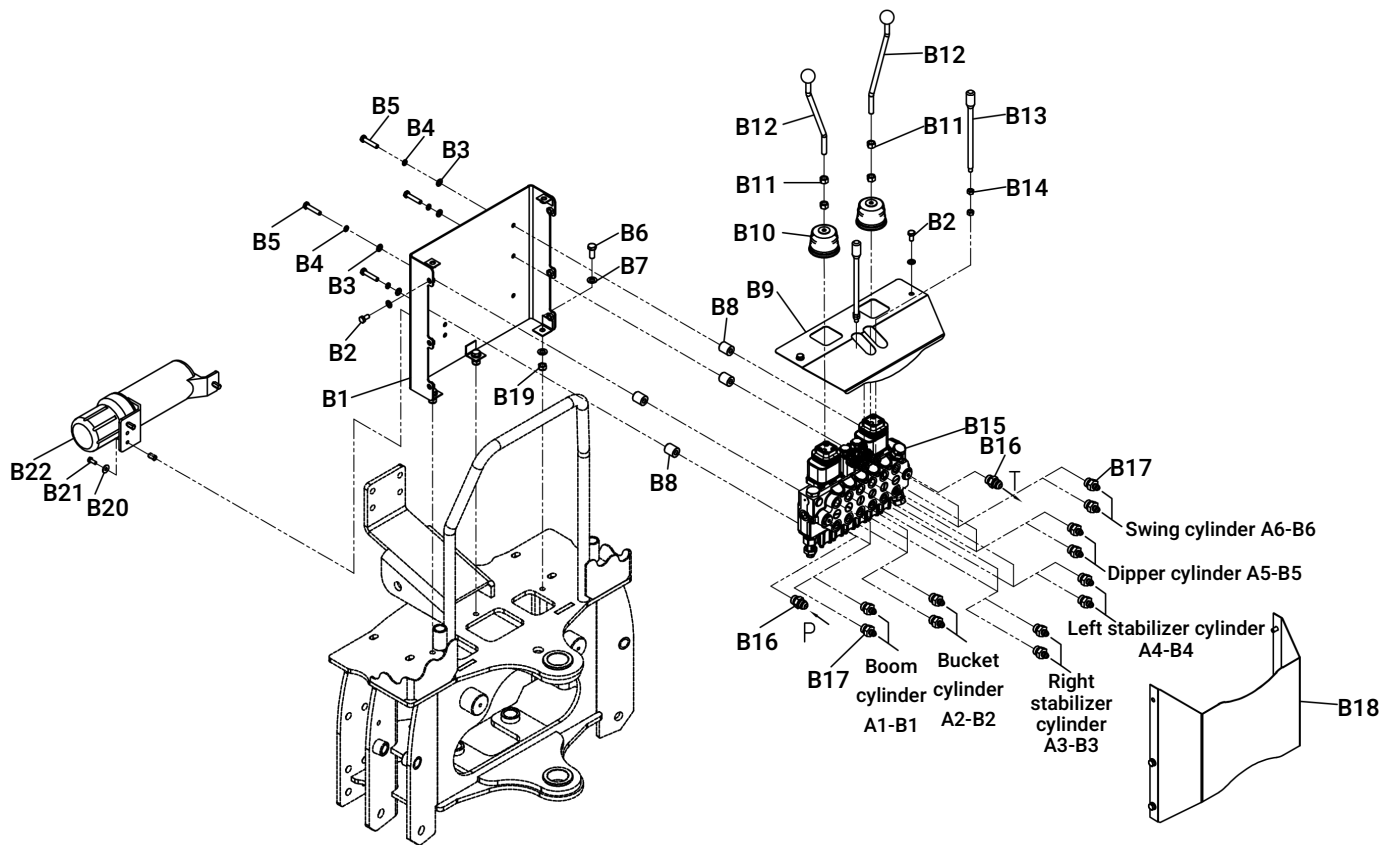

PARTS LIST

PART NO.	DESCRIPTION	QTY	PART NO.	DESCRIPTION	QTY
B1	Console base welding	1	B12	Curved handle M12X235	2
B2	Fully threaded hex bolts M8×16	8	B13	Italian valve straight handle M8X210	2
B3	Large washer Ø8	12	B14	Hex nuts M8	4
B4	Standard spring washers Ø8	12	B15	Six-way multi-way valve	1
B5	Fully threaded hex bolts M8×30	4	B16	Transition joint 12UNF3/4	2
B6	Fully threaded hex bolts M10×30	3	B17	Transition joint 08UNF3/4	12
B7	Plain washers Ø10	6	B18	Console cover	1
B8	Valve spacer	4	B19	Non-metallic insert hex lock nuts M10	3
B9	Console cover	1	B20	Plain washers Ø6	2
B10	Protective cover 60×120	2	B21	Hexagon bolt M6x10	2
B11	Hex nuts M12	4	B22	Tool barrel	1

4. Boom rotation assembly

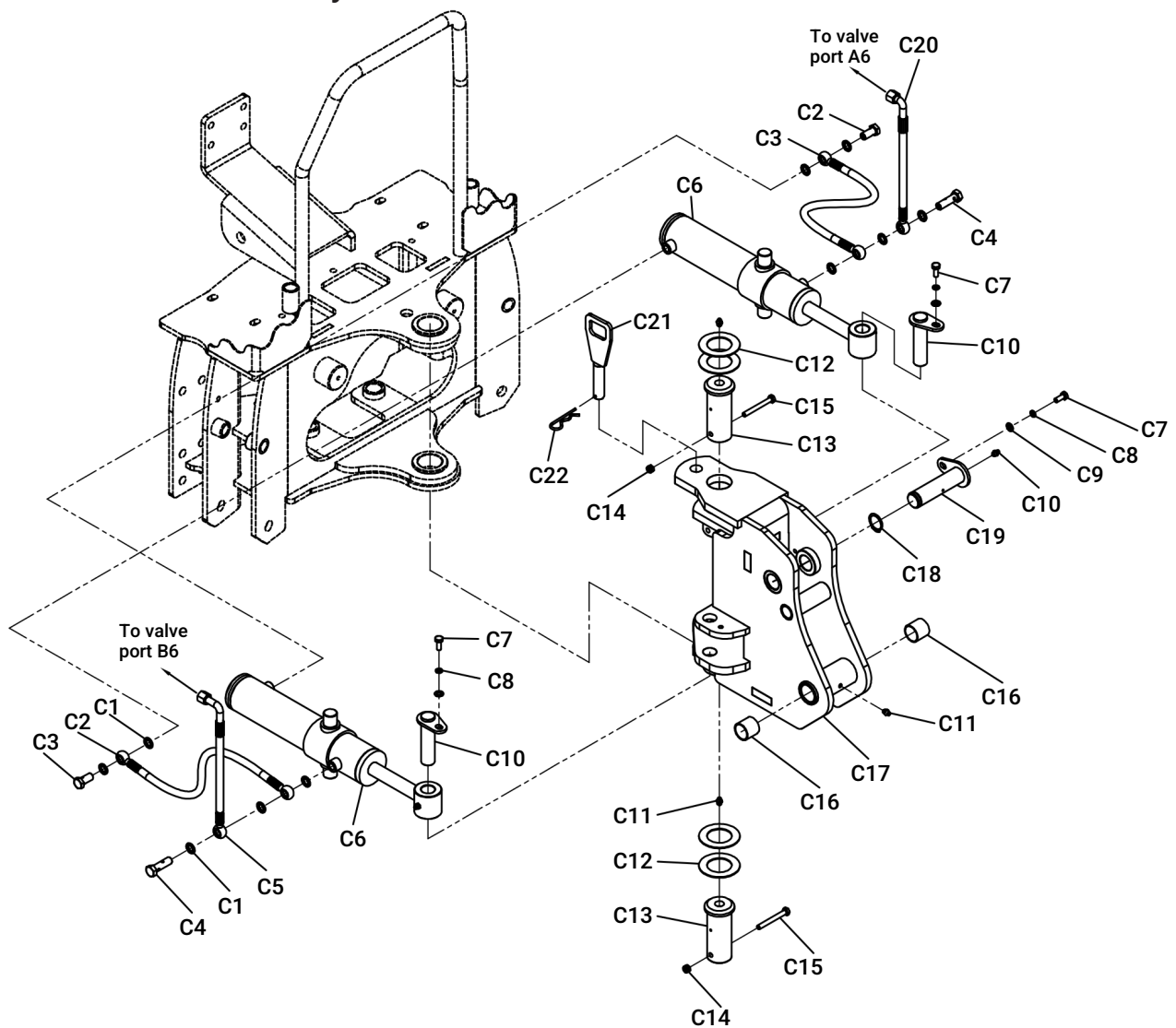

PARTS LIST

PART NO.	DESCRIPTION	QTY	PART NO.	DESCRIPTION	QTY
C1	Combination washer 13.7x20.6x2	10	C12	Spacer	4
C2	Steering tee oil pipe	2	C13	Suspension pin	2
C3	Hollow bolt G1/4	2	C14	Non-metallic insert hex lock nuts M8	2
C4	Hollow bolt (extended) G1/4	2	C15	Fully threaded hex bolts M8X70	2
C5	Steering right cylinder oil pipe	1	C16	Bushing C30x34x30	2
C6	Steering cylinder 60x205	2	C17	Steering welding	1
C7	Fully threaded hex bolts M8X20	3	C18	Shaft retaining ring Ø30	1
C8	Standard spring washers Ø8	3	C19	Pin welding 128	1
C9	Plain washers Ø8	3	C20	Steering left cylinder oil pipe	1
C10	Pin welding 105	2	C21	Swivel joint pin	1
C11	Straight-through pressure oil cup M8x1	4	C22	R pin Ø4	1

5. Boom assembly

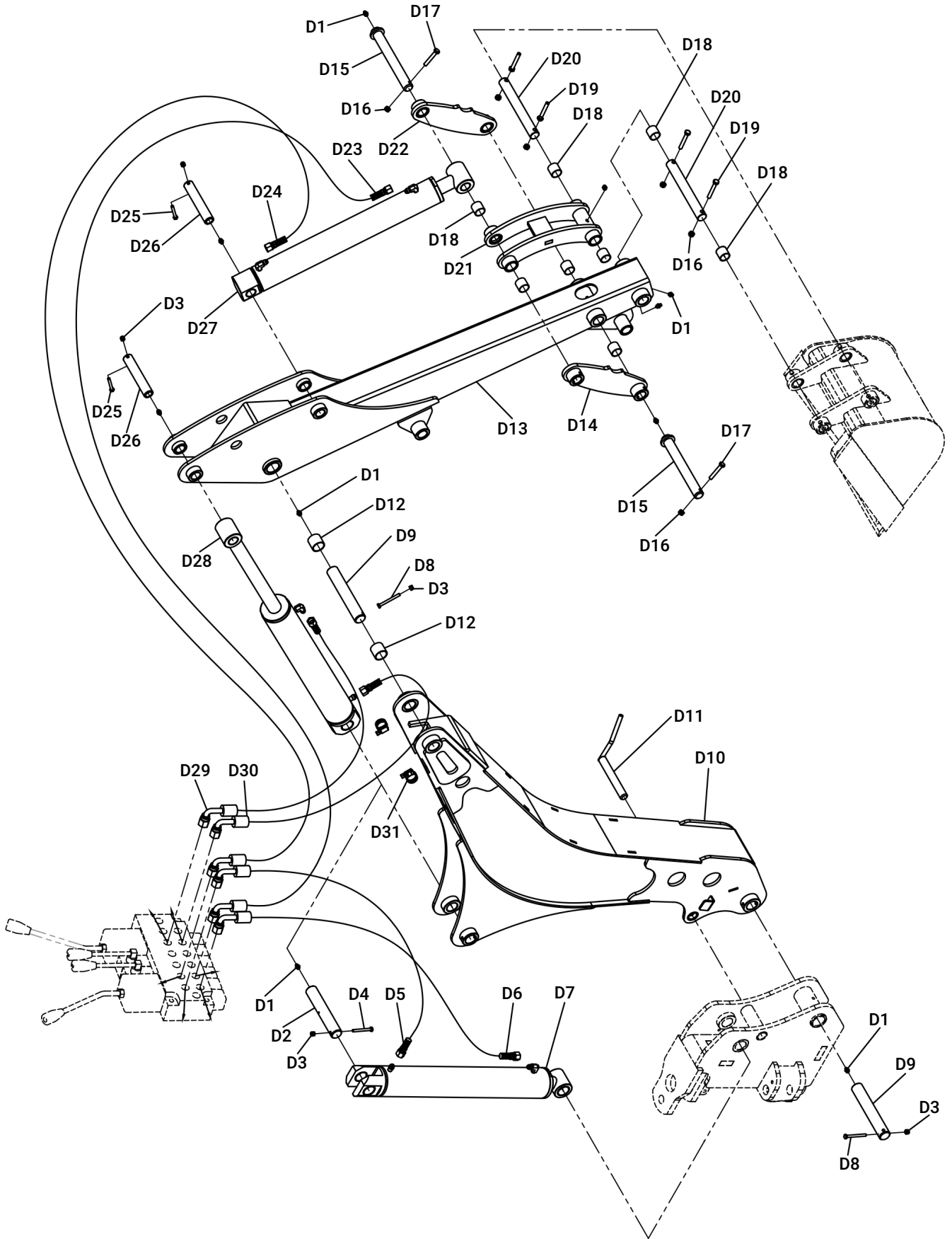

PARTS LIST

PART NO.	DESCRIPTION	QTY	PART NO.	DESCRIPTION	QTY
D1	Straight-through pressure oil cup M8	11	D17	Fully threaded hex bolts M8×50	2
D2	Pin 165	1	D18	Bushing C25×28×25	8
D3	Non-metallic insert hex lock nuts M6	5	D19	Fully threaded hex bolts M8x55	4
D4	Hex head bolts M6x55	1	D20	Bucket fixing pin Ø25x202	2
D5	Boom oil cylinder inlet pipe	1	D21	Connecting rod weldment	1
D6	Boom cylinder oil outlet pipe	1	D22	Connecting rod welding	1
D7	Boom cylinder 70x404	1	D23	Bucket cylinder oil outlet pipe	1
D8	Fully threaded hex bolts M6x0	2	D24	Bucket cylinder oil inlet pipe	1
D9	Pin shaft Ø30x181	2	D25	Fully threaded hex bolts M6×50	2
D10	Big Boom Welding Parts	1	D26	Pin shaft Ø25x137	2
D11	Pin welding 142	1	D27	Bucket cylinder 60x400	1
D12	Bushing C30x34x30	2	D28	Stick cylinder 70x415	1
D13	Small boom assembly	1	D29	Stick cylinder oil outlet pipe	1
D14	Connecting rod welding 2	1	D30	Stick cylinder oil inlet pipe	1
D15	Socket welding 214	2	D31	Hose clamp	4
D16	Non-metallic insert hex lock nuts M8	6			

6. Stabilizer legs assembly

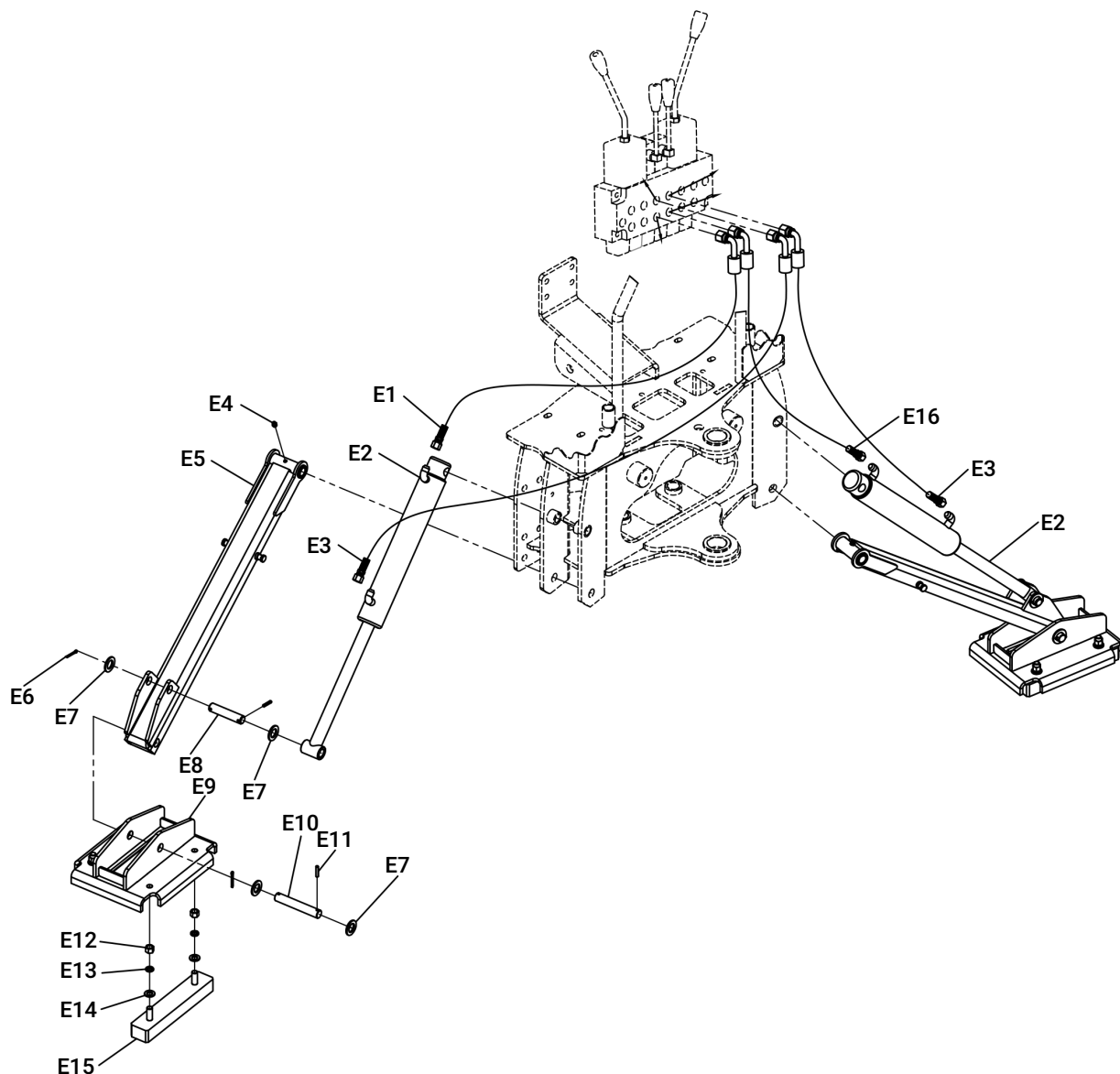

PARTS LIST

PART NO.	DESCRIPTION	QTY	PART NO.	DESCRIPTION	QTY
E1	Right outrigger cylinder oil inlet pipe	1	E9	Bottom plate weldment	2
E2	Outrigger cylinder 50.8x285	2	E10	Strut fixing pin Ø20x123	2
E3	Outrigger cylinder oil outlet pipe	2	E11	Spring pin 5x30	4
E4	Straight-through pressure oil cup M8	2	E12	Hex nuts M12	8
E5	Strut weldment	2	E13	Standard spring washers Ø12	8
E6	Cotter pin 4x32	4	E14	Plain washers Ø12	8
E7	Plain washers Ø20	8	E15	Rubber mat	4
E8	Outrigger cylinder fixed pin Ø20x93	2	E16	Oil inlet pipe of left outrigger oil cylinder	1

7. Bucket and thumb parts

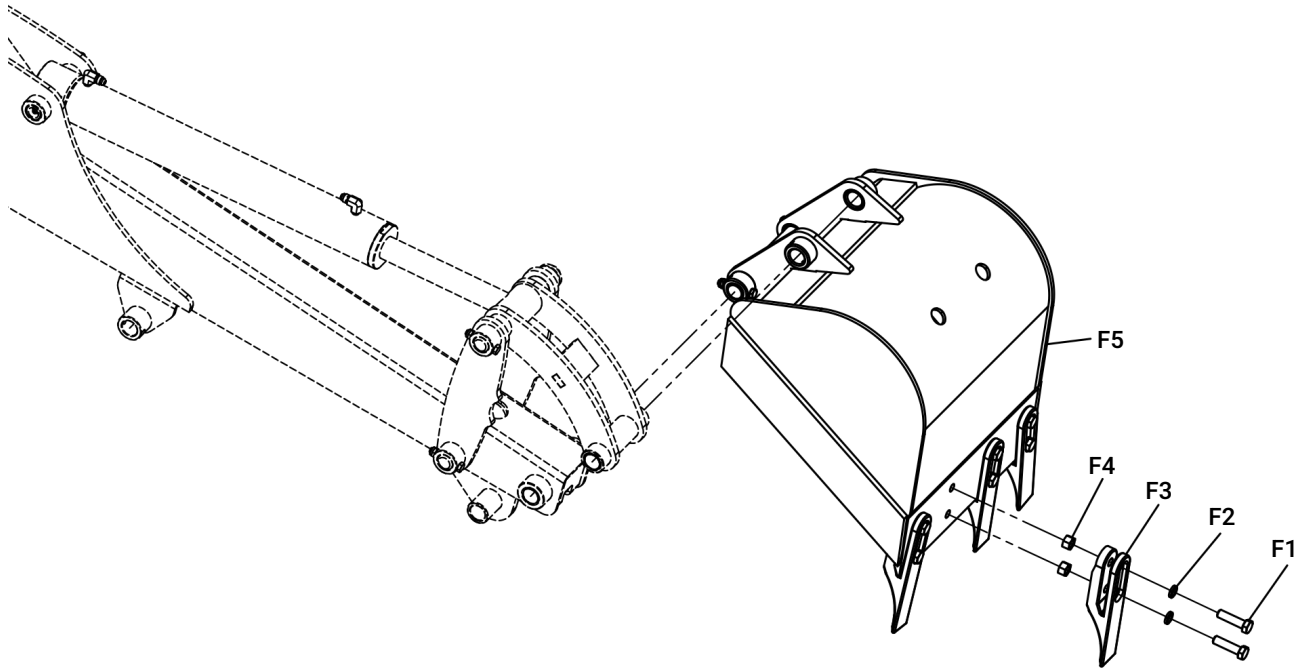

PARTS LIST

PART NO.	DESCRIPTION	QTY	PART NO.	DESCRIPTION	QTY
F1	Hexagonal bolt(fine pitch) M12x45	8	F4	Hexagon nut(fine pitch) M12	8
F2	Spring washer Ø12	8	F5	Bucket body welding 15"	1
F3	Tooth	4			

8. Skid steer loader hitch assembly

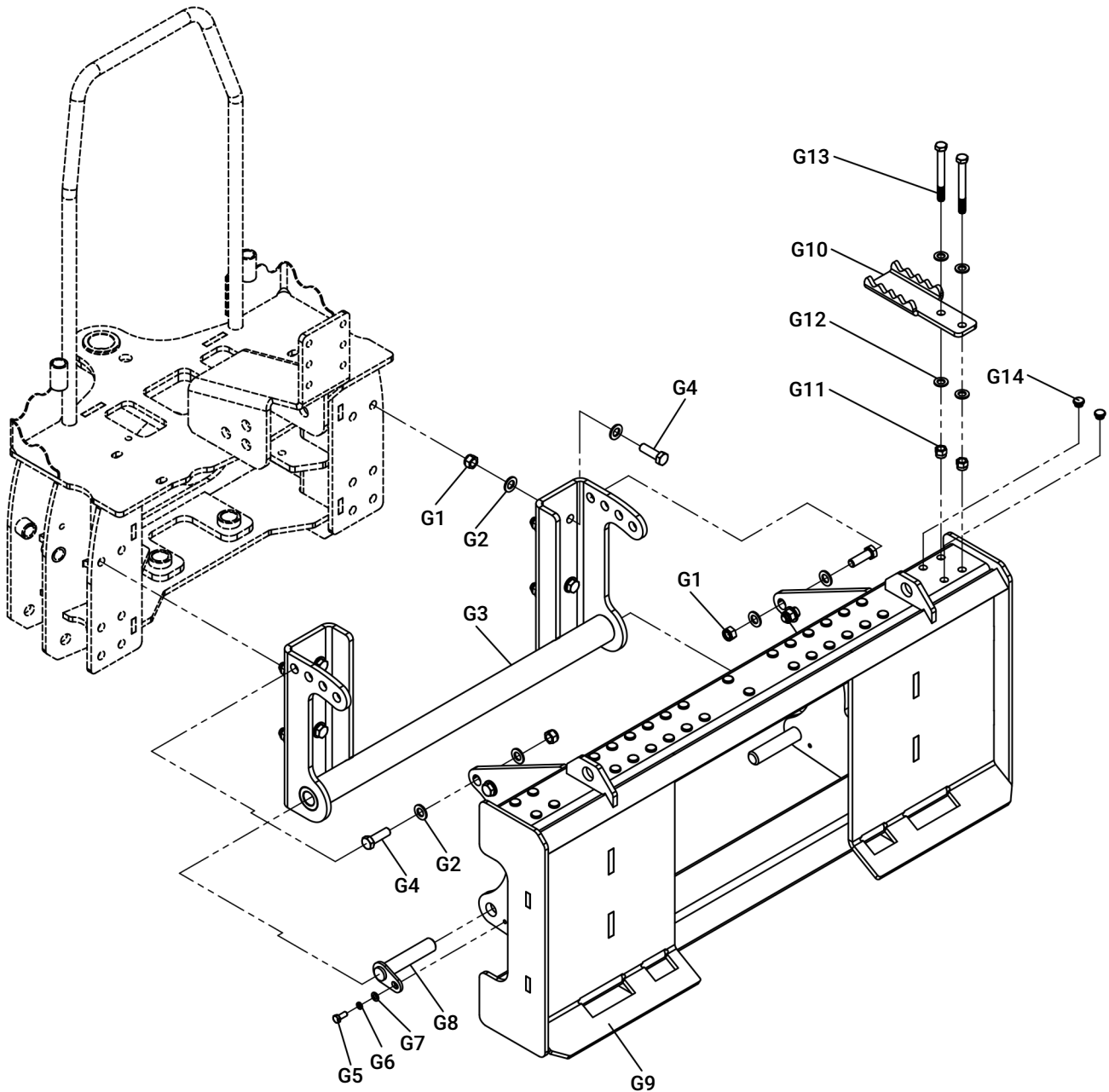

PARTS LIST

PART NO.	DESCRIPTION	QTY	PART NO.	DESCRIPTION	QTY
G1	Non-metallic insert hex lock nuts M14	12	G8	Pin welding	2
G2	Plain washers Ø14	24	G9	Slip hook welding	1
G3	Suspension connection plate welding	1	G10	Pedal	2
G4	Fully threaded hex bolts M14x45	12	G11	Non-metallic insert hex lock nuts M12	4
G5	Fully threaded hex bolts M8x20	2	G12	Plain washers Ø12	8
G6	Spring washers Ø8	2	G13	Hex head bolts M12x110	4
G7	Plain washers Ø8	2	G14	Yellow hole plug	32

9. Flow control valve assembly

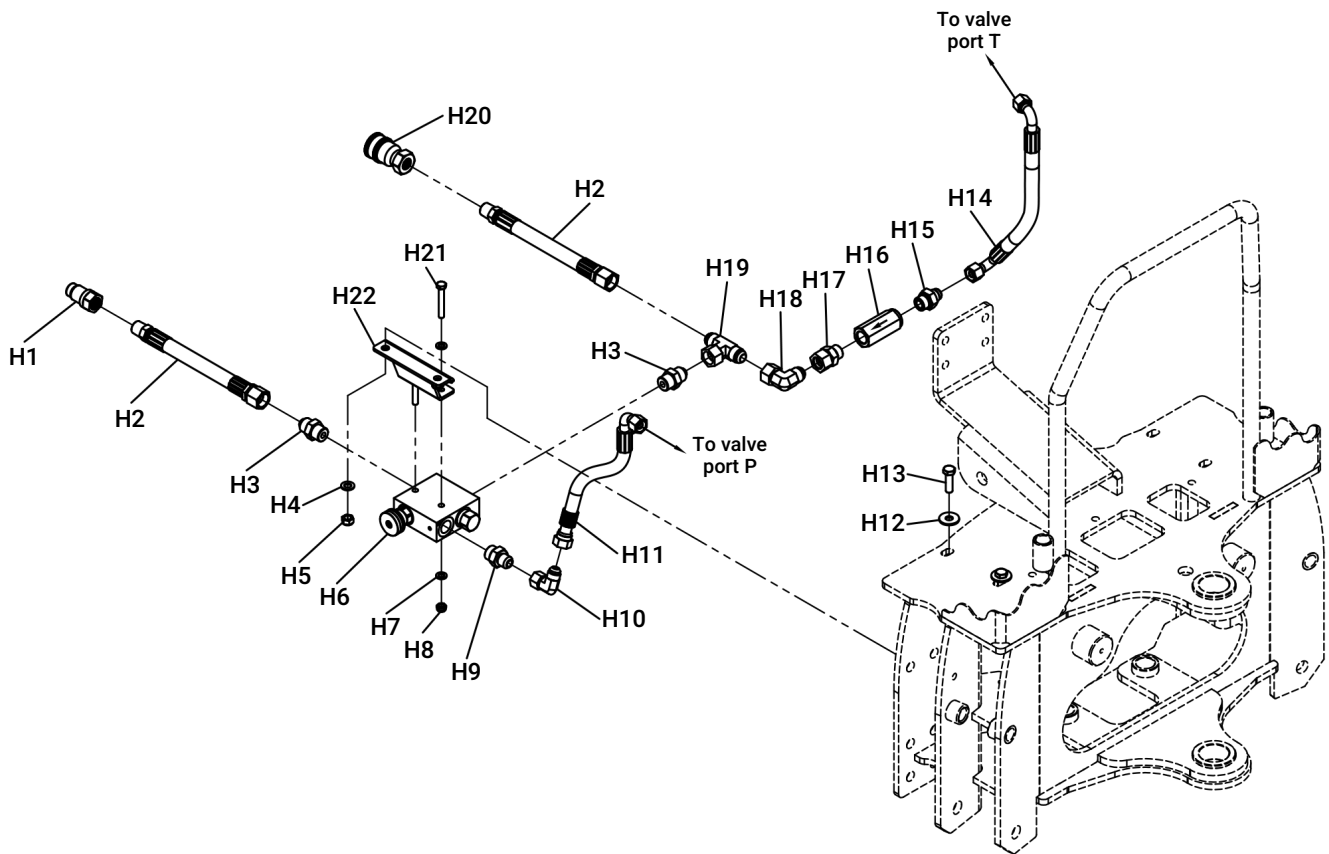

PARTS LIST

PART NO.	DESCRIPTION	QTY	PART NO.	DESCRIPTION	QTY
H1	Quick coupler 1/2 NPT (male)	2	H12	Large washer	2
H2	Speed control valve connecting oil pipe	2	H13	Fully threaded hex bolts M10×35	2
H3	Pump suction fitting	2	H14	Multi-way valve oil outlet pipe	1
H4	Plain washers Ø10	2	H15	Transition joint 12R1/2	1
H5	Non-metallic insert hex lock nuts M10	2	H16	Check valve	1
H6	Control valve	1	H17	Transition joint	1
H7	Plain washers Ø8	4	H18	Right angle connector	1
H8	Non-metallic insert hex lock nuts M8	2	H19	Tee joint	1
H9	Transition joint 12UNF7/8	1	H20	Quick coupler 1/2 NPT (female)	1
H10	Right angle connector	1	H21	Fully threaded hex bolts M8×55	2
H11	Multi-way valve oil inlet pipe	1	H22	Speed control valve mounting plate	1

10. Hydraulic line connection diagram

