

20 TON FIREWOOD PROCESSOR CONVEYOR

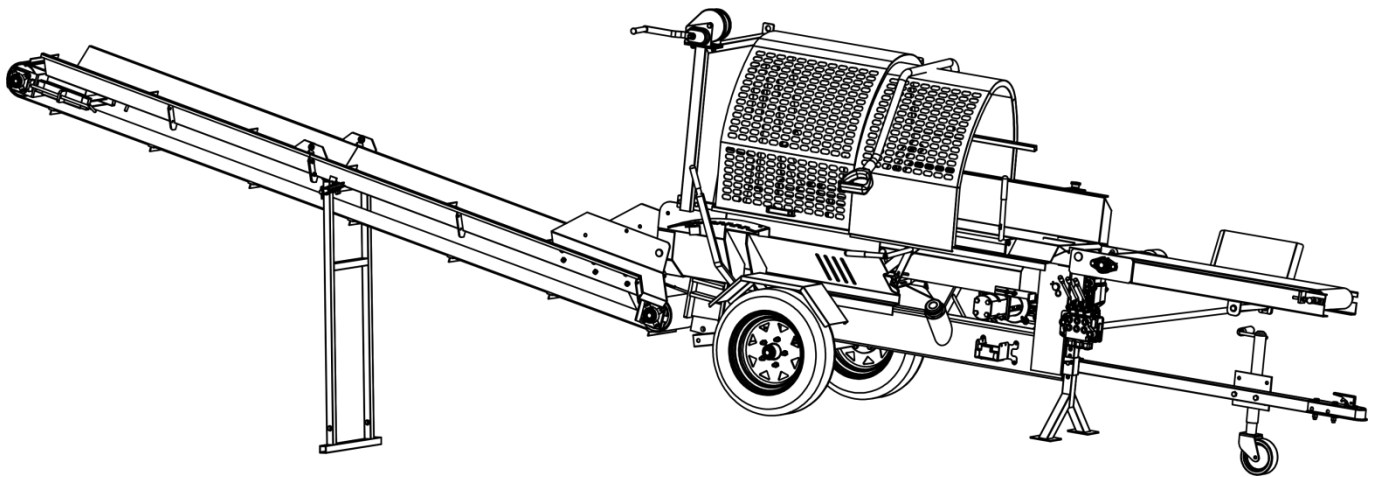

⚠ WARNING

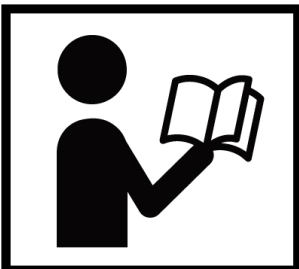

- Please read and understand the product manual completely before assembly
- Check against the parts list to make sure all parts are received
- Wear proper safety goggles or other protective gears while in assembly
- Do not return the product to dealer. They are not equipped to handle your requests.

Missing parts or questions on assembly?

Please call: 1-877-761-2819 or email: cs@tmgindustrial.com

TABLE OF CONTENTS

1.1	Introduction	4
1.2	Purpose of use	4
1.3	Machine models and basic information	4
1.4	Operating conditions	5
1.5	Safety instructions	5
1.6	Noise and vibration.....	5
2	INSTALLATION OF THE MACHINE.....	8
2.1	Delivery inspection	8
2.2	Main components of the machine	8
2.3	Installation the machine.....	9
3	SETTING UP BEFORE USE.....	18
3.1	Connect terminal to battery.....	18
3.2	Engine.....	18
3.3	Add the hydraulic oil.....	19
3.4	Add the saw chain lubrication.....	19
3.5	Lubrication.....	19
4	OPERATING THE MACHINE.....	20
4.1	Machine controls and functions	20
4.2	Performing a test run on the machine	21
4.3	Wood feeding, cutting and splitting	21
4.4	Using the discharge conveyor	22
4.5	After use	22
5	MAINTENANCE	23
5.1	Disconnecting the machine from its power source.....	23
5.2	Adjusting the log length.....	23
5.3	Height adjustment of the splitting knife.....	23
5.4	Replacing the splitting knife	24
5.5	Adjusting the tightness and alignment of the discharge conveyor belt	24
5.6	Cutting blade and drive end	24
5.7	Changing the hydraulic oil	25
5.8	Conveyor maintenance.....	25
5.9	Lubrication	26
5.10	Washing and cleaning.....	26
5.11	Storage.....	26
5.12	Maintenance table	27
6	FAILURES AND REMEDIAL MEASURES	28
6.1	Jamming of the cutting blade.....	29

6.2	Jamming of the wood on the splitting knife.....	29
7	HYDRAULICS DIAGRAM	30
8	EXPLODED VIEW	31
8.1	Main exploded drawing.....	31
8.2	Feed conveyor exploded drawing.....	33
8.3	Discharge conveyor exploded drawing.....	34

GENERAL INFORMATION

1.1 INTRODUCTION

The purpose of this manual is to ensure that the machine is used in the manner intended by the manufacturer, taking safety into consideration. Everyone operating the machine or working in close proximity to it must study this manual carefully.

This manual is intended for operators with the appropriate expertise. For this reason, operators are expected to have the general knowledge and basic skills required for working with this kind of machinery. Familiarise yourself with the manual before installing the machine and beginning operation. Carefully study the machine's features and safety equipment before operation. Always keep this manual with the machine. The instructions, descriptions and technical specifications in this manual are based on the latest information with regard to the workings of the machine at the time of printing. However, the manufacturer develops and updates the machine continuously and therefore reserves the right to change the machine's features and safety-related properties without separate notification.

Additional information on TMG INDUSTRIAL products is available on our website at www.tmgindustrial.ca

Keep this manual in the immediate vicinity of the machine.

1.2 PURPOSE OF USE

The firewood processor is designed for the preparation of firewood from pruned wood or logs. The firewood processor must not be used to process any treated wood, such as is found in construction waste, for example. Sand, nails or other impurities in the wood may damage the machine.

The maximum diameter of the logs to be processed is 15" (38 cm). This limit must not be exceeded. When estimating the diameter of the log you are about to cut, note that the shape of the log and other factors, such as branches and burrs, make the actual diameter larger, and may prevent the log from being fed to the machine. Do not split logs that exceed 24" (60 cm) in length.

1.3 MACHINE MODELS AND BASIC INFORMATION

Model	TMG-GLS20
Driving power	Gasoline engine 14HP
Weight	565 kg
Height/width/length in transport position	Transport position 251/136/262 (cm)
Input conveyor	41"X10"
Output conveyor	126"x10"
Saw bar/chain	18"
Max log diameter	15"
Max/min log length	Log max 24"; min 6-1/2"

The machine's serial number, date of manufacture, and model are indicated on the gray type plate located on the machine frame below the locking latch of the output conveyor, on the right side of the operator.

1.4 OPERATING CONDITIONS

The temperature range within which the machine can be operated is -20 to +30°C. In the winter, the operator must ensure that there is no risk of slipping in the working area.

- The working area must be level and clear of unnecessary items. No unauthorised persons must enter the working area. The machine may only be used in insufficient lighting conditions. These requirements must be met for the entire duration of the work.
- The machine may not be used indoors.

1.5 SAFETY INSTRUCTIONS

- This device is designed to be operated by only one operator. The danger zone is 10 m from the machine.
- Persons under 18 years of age may not operate the machine.
- The operator must ensure that use of the device does not cause danger to others and that there are no unauthorised persons in the danger zone.
- The machine may not be operated while under the influence of alcohol or other drugs, or when tired.
- The machine may not be operated unless the operator has familiarised themselves with this instruction manual.
- The machine has been designed solely for making firewood.
- The machine must be placed in the transport position whenever it is moved. When transporting the machine on a public road, it must be equipped with additional lights.
- The operator is not permitted to modify the structure or operation of the machine, or to remove protective equipment.
- The operator must wear ear protectors, sufficiently tight-fitting work clothing and gloves, protective goggles and safety footwear.
- Before starting up the machine, the operator must ensure that the machine and its guards are intact.
- Before starting up the firewood processor, the operator must ensure that all the control and safety devices are functional.
- When cleaning the machine or carrying out any maintenance, it must be disconnected from its power source.
- Note! Do not leave a running machine unsupervised!

1.6 NOISE AND VIBRATION

The firewood processor's sound power level, as specified in standard EN ISO 3744:2010, during a work cycle is 109 dB, while the maximum sound pressure at the operator's position during a work cycle is 95 dB. The estimated standard deviation of the reproducibility of the sound power level is 1.5 dB.

The vibration values do not exceed 2.5 m/s².

Warning symbols

TRAILER TOWING INSTRUCTION

- Off road towing only, not designed for highway transportation
- Maximum towing speed: 45 MPH
- Latch coupler to 2" hitch ball
- Release tow bar stabilizing stand and securely lock in position
- Attach safety tow chains to the tow vehicle
- Turn off the engine shut-off valve

TMG-MACH-4075

MAX TOWING SPEED

45 MPH

TMG-MACH-4077

⚠ WARNING!

PINCH POINT
KEEP HANDS CLEAR DURING OPERATION



TMG-MACH-4078

⚠ WARNING!

STAY AWAY FROM HIGH PRESSURE HYDRAULIC FLUID!

High pressure and temperature are developed in the hydraulic system. Hydraulic fluid escaping through a pin-size opening can cause skin damage

- Inspect hydraulic system regularly for leaks
- Never check leaks with hands while system is pressurized
- Seek medical attention immediately if injured by escaping fluid



TMG-MACH-4079

⚠ WARNING!

Moving parts can crush and cut. Pieces can fly out while splitting. Follow safety procedures when operating the splitter, otherwise serious injury could occur

- Always completely read the owner manual before operating the splitter
- Only one person can operate the splitter at one time
- Do not operate the splitter when someone else is helping to load the log
- Only operate the splitter when nobody else is within 10 feet
- Operator must stay in the designated spot while operating
- Only split wood along the same direction as the wood grain
- Keep hands away from wedge, endplate, hydraulic ram and split logs
- Do not leave splitter unattended during operation
- Do not set up splitter on slope or slippery surface



TMG-MACH-4080

CLEAR OFF REMAINING LOGS IN V-GROOVE

Logs might stay in the V-groove. Use this handle to clear off before next split

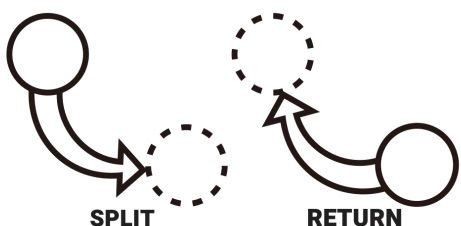

SPLIT **RETURN**

- Push handle downward, force ram moves forward to clear firewood
- Force ram returns automatically when it reaches the split point
- Push handle upward, force ram retracts back

TMG-MACH-4081

⚠ WARNING!

LOG STRIPPER
RETRACT WEDGE TO REMOVE STUCK WOOD



PINCH POINT
KEEP HANDS CLEAR OF WEDGE AND LOG STRIPPER

TMG-MACH-4076

FEED CONVEYOR BELT OPERATION

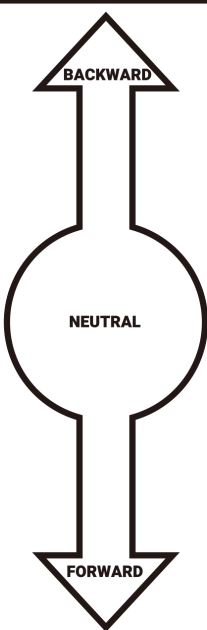

TMG-MACH-4082

⚠ WARNING!

ROTATING SHAFT CAN CAUSE SEVERE INJURY

KEEP HAIR AND LOOSE CLOTHING AWAY



TMG-MACH-4083

⚠ WARNING!

SERVICING MOVING EQUIPMENT CAN CAUSE SEVERE INJURY

LOCK OUT POWER BEFORE MAINTENANCE



TMG-MACH-4084

⚠ WARNING!

MOVING PARTS CAN CAUSE SEVERE INJURY

STAY AWAY



TMG-MACH-4085

⚠ WARNING!

**LOCK OUT POWER
BEFORE REMOVING
SHIELD GUARD**

TMG-MACH-4086

STABILIZING STAND

**FOLD DOWN AND LOCK
THE STAND IN POSITION
BEFORE SPLITTING LOG**

TMG-MACH-4087

INSTRUCTIONS FOR OPERATION

- Load log onto feeding conveyor belt
- Adjust to set the cut length
- Turn on conveyor "Forward" to feed log to the set position
- Pull chainsaw to cut the log
- When chainsaw returns back to its original position, the force ram starts to move to push log forward
- Force ram returns back to its original position when it reaches the split point

NOTE: Logs might stay and pile up in the V-groove. Clear off before next split. Use the handle to operate force ram to clear piled up logs

TMG-MACH-4088



INSTALLATION OF THE MACHINE

2.1 DELIVERY INSPECTION

Dispose of the machine's packaging material in an environmentally friendly manner.

Check that the machine has not sustained any damage during transit, and ensure that all necessary parts are included in the package. In the event of any defects or damage, contact the retailer immediately.

2.2 MAIN COMPONENTS OF THE MACHINE

The main components of the firewood processor are represented in the figure below.

- A. Output conveyer
- B. Cutting and splitting unit
- C. Control unit
- D. Input conveyer
- E. Trailer

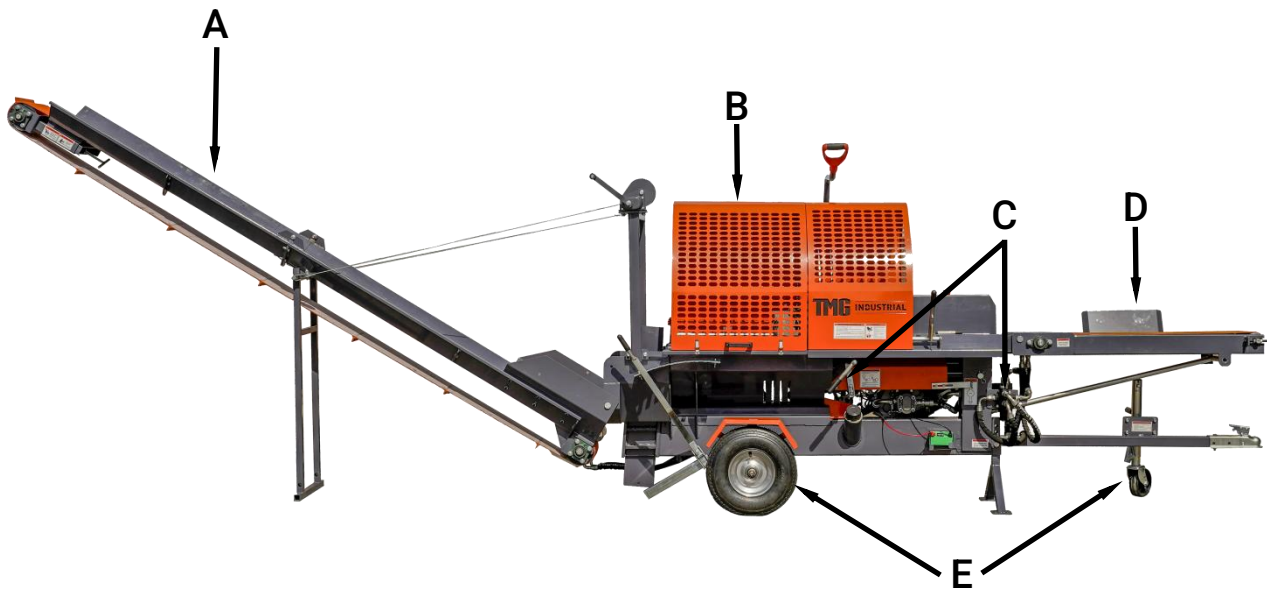
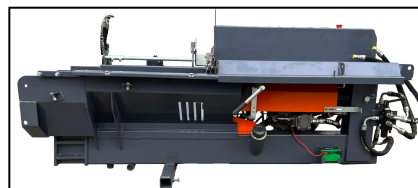

Figure 1. Main components of the machine

2.3 INSTALLATION THE MACHINE

1. Lift Unit off of the crate, if using straps be careful not to bend or stress any components

⚠ Before lifting, ensure that no other persons or animals are within the machine's danger zone! Monitor the area and ensure that it stays empty for the entire duration of the lifting!



2. Find the wheel axle and two tires. Then install the axle into the square tube at the rear of the processor, center the axle in the housing and the tighten the bolts.



3. Install the tire and hub onto the axle and the tighten the bolts.



4. Install the tripod leg in front mount, pass through with safety pin and secure with R pin, then lower processor to the ground.

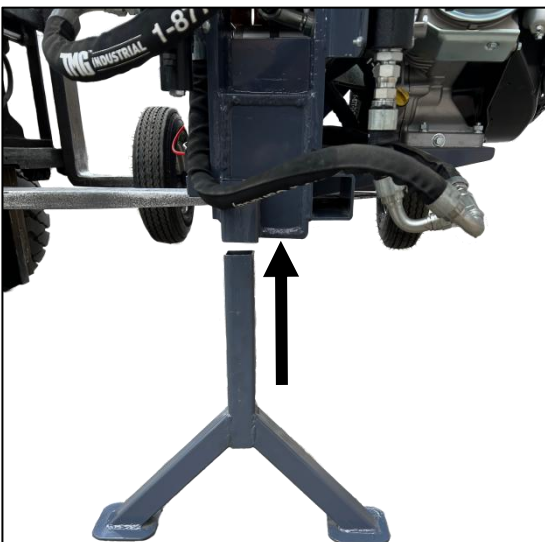

5. Install the sawing guard with 6 - 13mm nuts and bolts.

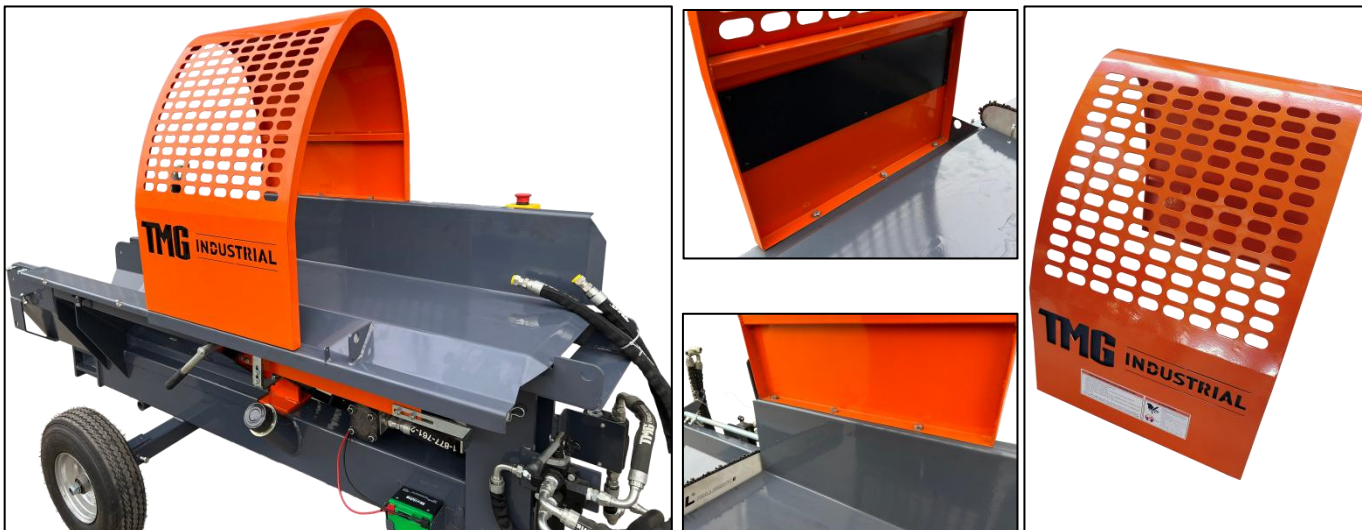

6. Install the wood gripper and tension spring.



Noted: In order to effectively protect the surface from scratches, please separate wood gripper and saw table with cardboard when installing wood gripper.

7. Install the chainsaw arm to swivel plate with 3 bolts and nuts provided the bolts will be installed through the chainsaw arm into the threaded holes on the swivel plate. screw the gas cylinder into the swivel head that is already mounted to the sawing guard.



8. Install the adjust wedge assemble

8.1 Remove bolts and nuts from side of processor, install wedge adjustment plate and tighten 2 – bolts & nuts.

8.2 Assemble the adjusting rod assembly

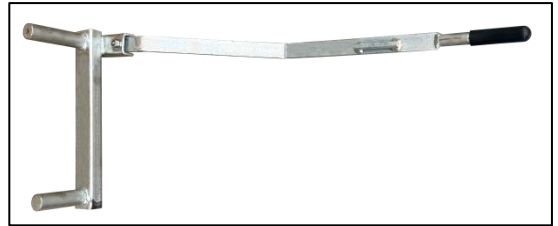
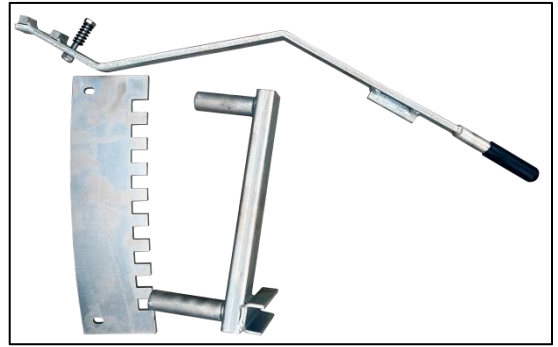
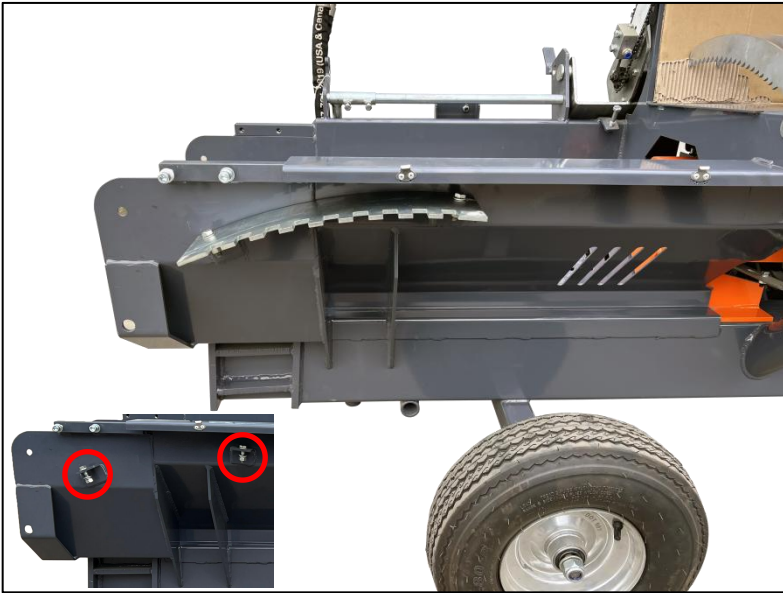

8.3 Slide the swivel bar through the mount behind the axle, tighten the bolt & washer .

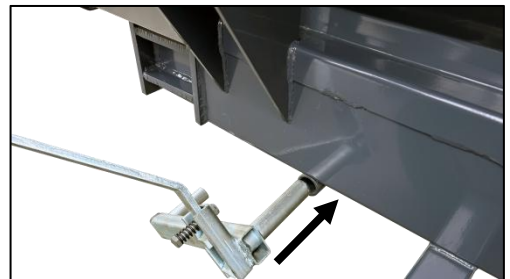

9. Pull the adjusting rod into position, then insert wedge.

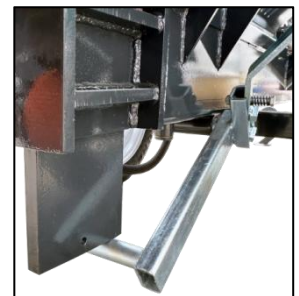

10. Install the log splitter guard. Noted: The stopper needs to be flipped into the splitter chamber.

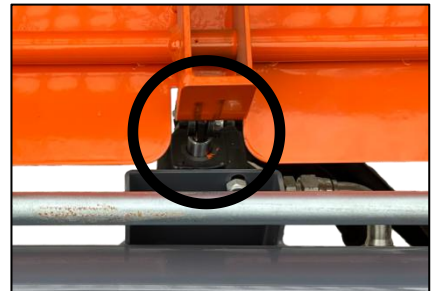
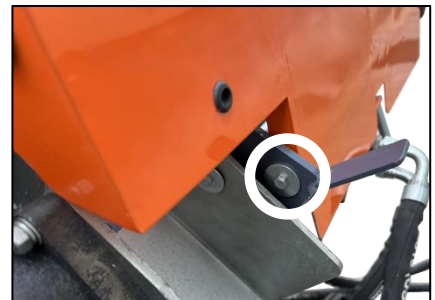

⚠ After installing the the log splitter guard, open and close the log splitter guard several times to check whether the limit switch works normally. When the log splitter guard is opened, the limit switch is pressed down, and the limit switch is reset after the log splitter guard is closed.

11. Install the chainsaw lubrication canister and connected to the chain saw.

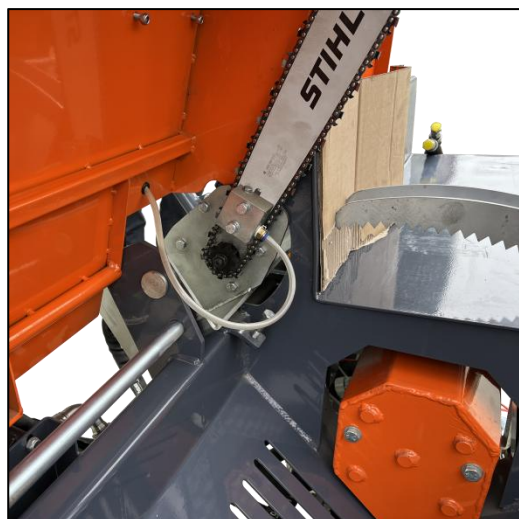

12. Install the feed delivery system.

⚠ Installing the feed delivery system requires two people to work together. When connected to the firewood processor, one person needs to hold or support the feed system with other objects, until feed support rod adjustment is complete. otherwise the feed system will fall, causing personal injury and machine damage.

1. Connect the feed delivery system to the firewood processor, pin through and secure with cotter pin.

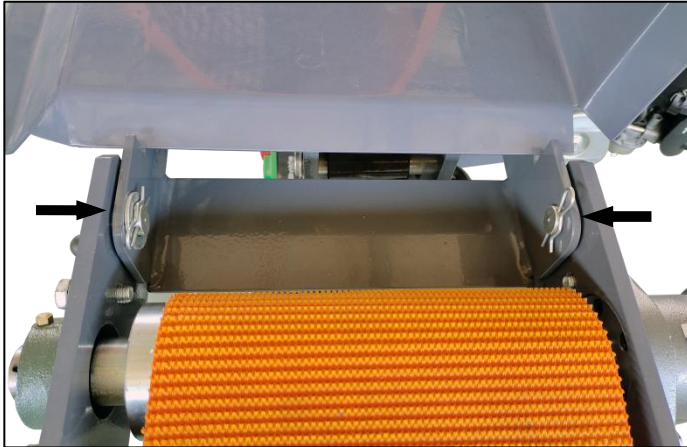

2. Insert the support rod into the specified position and rotate the end bolt of the support rod to level the feed delivery system.

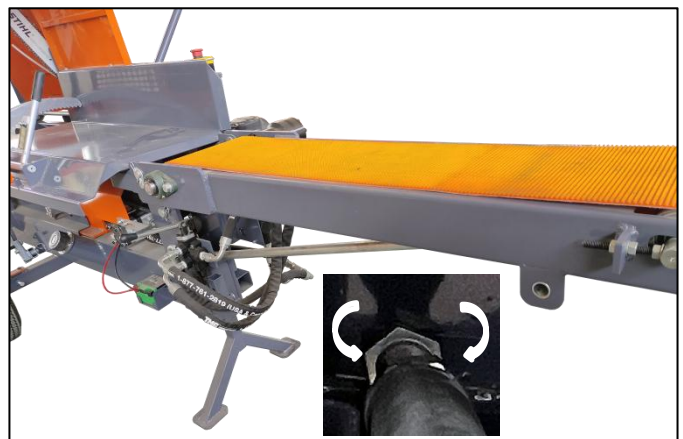
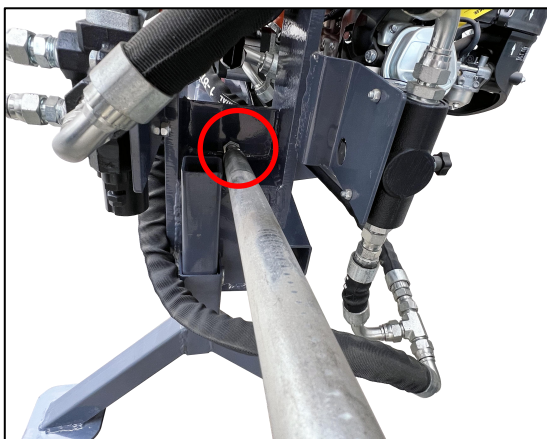

3. Install the feed damper and connect hydraulic line to hydraulic motor of feed delivery system.



13. Install the discharge conveying system.

1. Mount the winch support arm to the processor with the 4 bolts provided.



2. Install the fixing plate on the conveyor base and tighten all bolts

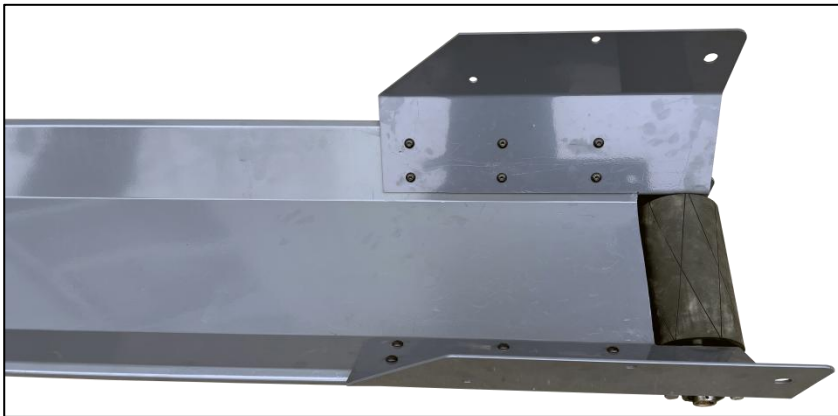

3. Mount the conveyor base section to the rear of the processor using the pin through and secure with cotter pin.

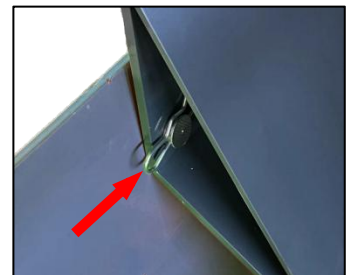
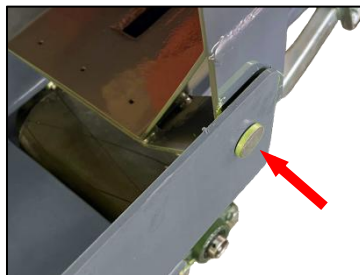

4. Lift the conveyor section up and line up the holes in the leg with the tab holes and push the support leg shaft through. Loosen the winch cable and mount rollers to the pins and put in R-pins.



5. Lift the leg and put support leg fixed shaft through the leg and tabs to hold it in place, Lower the conveyor and place the second section of the conveyor upside down on the first section. Install bolts and washers at swivel point, remember when tightening the nuts that the conveyor section must be able to swivel, so do not tighten too much.

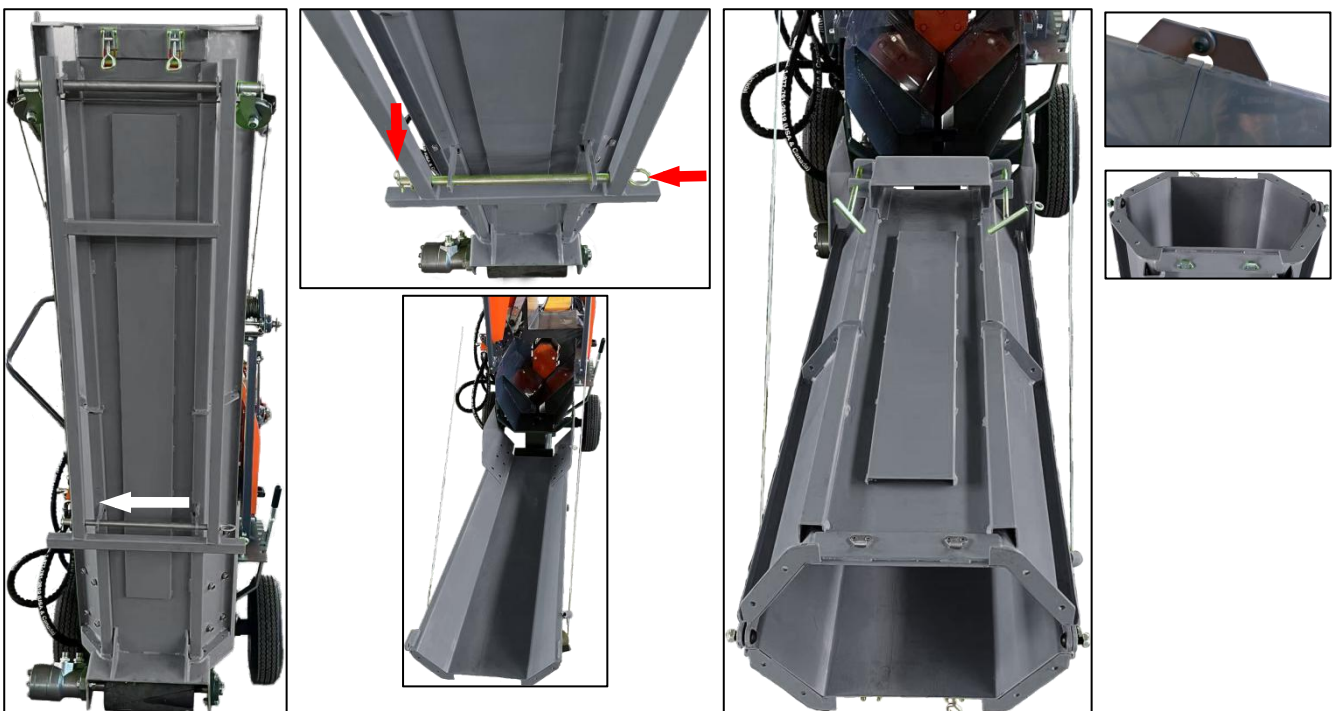

6. Lift Swing upper section of conveyor out and install the tail pulley support, when the conveyor is extended for use the adjustable buckle should be engaged.



7. Install conveyor belt. Connect the belt together and put the pin through the lacing, turn adjusting bolts until conveyor is snug.

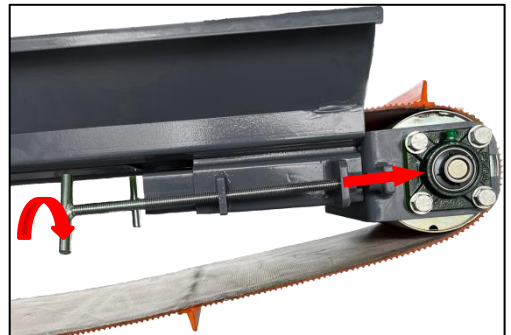

8. Install safety chains to avoid leg toppling and protect the machine and personnel.



9. Installed the belt support rod shown in this photo that is running along the side of the conveyor is used for retaining the belt when the conveyor is in travel position.

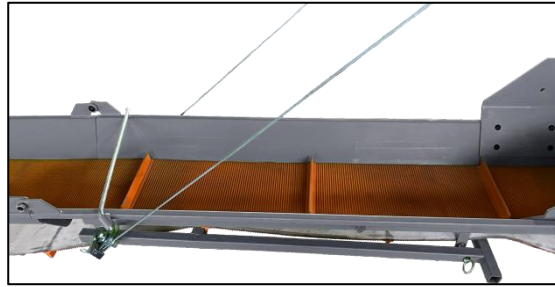
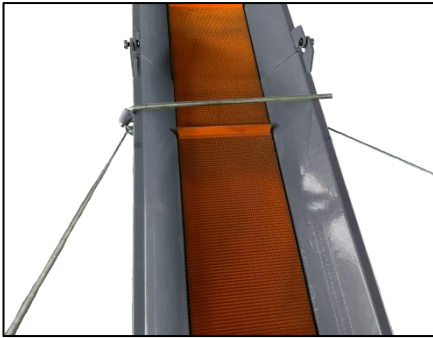

The belt support rod is in its rest position in the photo and is out of the way of the belt and the machine can be operated as normal.

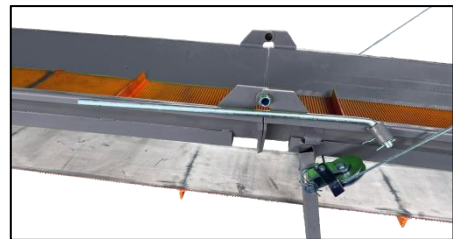

10. Install the extension plate onto the rear of the processor, connect hydraulic line to hydraulic motor of discharge conveying system.

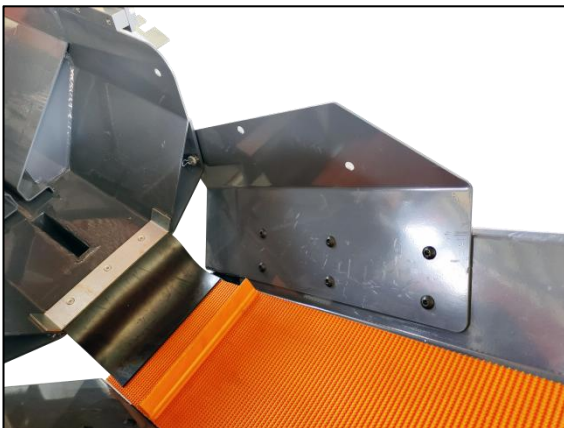

14. Install the mudguard.



SETTING UP BEFORE USE

3.1 CONNECT TERMINAL TO BATTERY

1. Battery Connection

Always connect the cables in the following sequence to avoid possible shock.

- Connect one end of the red (+) cable to compressor engine's starter solenoid terminal.
- Connect one end of the black (-) cable to engine's mounting bolt, frame bolt, or other good engine ground connection.
- Connect other end of the red (+) cable to battery positive (+) terminal.
- Connect other end of the black (-) cable to battery negative (-) terminal as shown.
- Coat terminals and cable ends with grease if they are to remain permanently connected .

⚠ Be careful not to connect the battery in reverse polarity, as this will short circuit the battery charging system. Since the engine has not yet been grounded to the battery ground, your uninsulated tool handles can cause a short circuit if they also touch a grounded part while tightening the positive battery cable end.

2. Battery Disconnection

Once operating, the engine will continue to run whether the battery is connected or not. The battery should be disconnected from the engine when the processor is not going to be used for a long period of time. Always disconnect cables in this reverse sequence to the above connection sequence.

- First, disconnect the black (-) cable from the battery negative (-) terminal.
- Next, disconnect the red cable from the battery positive (+) terminal.
- Disconnect the black (-) cable from the grounding connection.
- Disconnect the red (+) cable from the starter solenoid terminal.

3.2 ENGINE

1. Add Oil To The Engine

- Place pressure washer on a flat, level surface.
- Clean area around oil fill and remove yellow oil fill cap.
- Using oil funnel (optional), slowly pour contents of provided oil bottle into oil fill opening.
- Replace oil fill cap and fully tighten

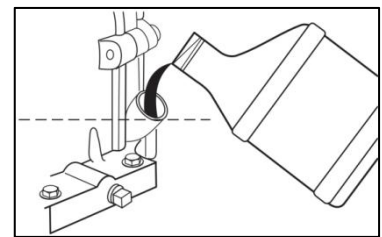
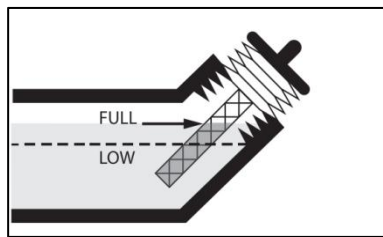
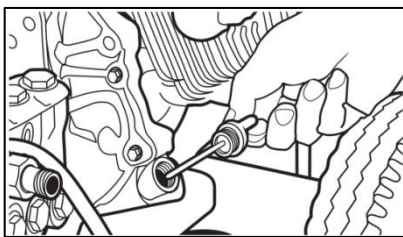

2. Add Fuel To the Engine

⚠ Failure to use fuel as recommended in this manual will void the warranty.

⚠ Fuel and fuel vapor are extremely flammable and explosive. Fire or explosion from misuse of fuel can cause severe burns and even death.

DO NOT use unapproved gasoline such as E85 (85% ethanol/15% gasoline).

DO NOT mix oil with gasoline.

DO NOT modify engine to run on alternate fuels.

If engine doesn't run properly after fueling, switch fuel brands. The engine is certified to run on gasoline. The emission control system for this engine is EM (Engine Modifications).

WHEN ADDING FUEL TO THE ENGINE, OBSERVE THE FOLLOWING STEPS:

1. Turn engine OFF and let it cool for at least two minutes before removing fuel cap. Loosen fuel cap slowly to release pressure.
2. Fill fuel tank outdoors.
3. DO NOT overfill fuel tank. Leave room for fuel to expand.
4. Wait for spilled fuel to evaporate before cranking engine.
5. Keep fuel away from sparks, open flames, pilot lights, heat and other ignition sources.
6. DO NOT light a cigarette or smoke near open fuel tank or container.
7. Clean area around fuel fill cap and slowly remove cap to allow any pressure to escape.
8. Slowly add unleaded gasoline (A) to fuel tank (B). Use extreme caution not to fill fuel above baffle (C). This allow appropriate space for fuel expansion.
9. Install fuel cap and allow any spilled fuel to evaporate before starting engine.

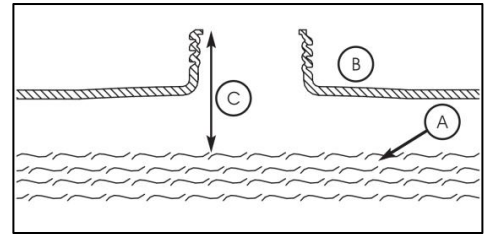
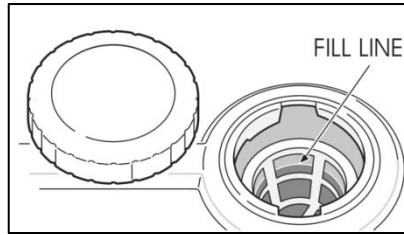
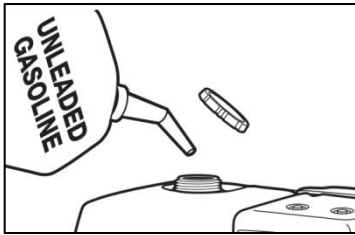

3.3 ADD THE HYDRAULIC OIL.

1. Open filler cap of the hydraulic oil tank.
2. The hydraulic tank capacity is 26 l. you only add the 20l into the tank.

Noted: Add 26L AW32 hydraulic oil, in cold climates AW22 can be used and in hot conditions AW46 can be used.

3. Close filler cap of the hydraulic oil tank.



3.4 Add the saw chain lubrication.



3.5 LUBRICATION

All of the firewood processor's lubrication points, which require Vaseline. There are four lubrication points.

1. Grease nipple of the input conveyor drive roller .
2. Nipples (3 pcs) of the output conveyor's drive roller.

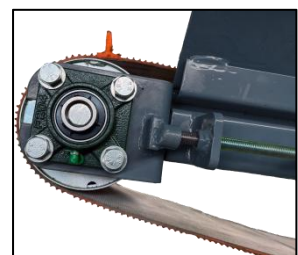
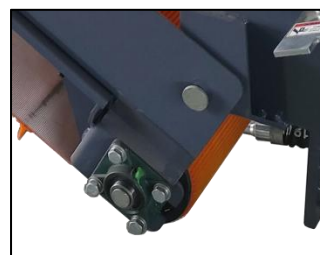

OPERATING

4.1 MACHINE CONTROLS AND FUNCTIONS

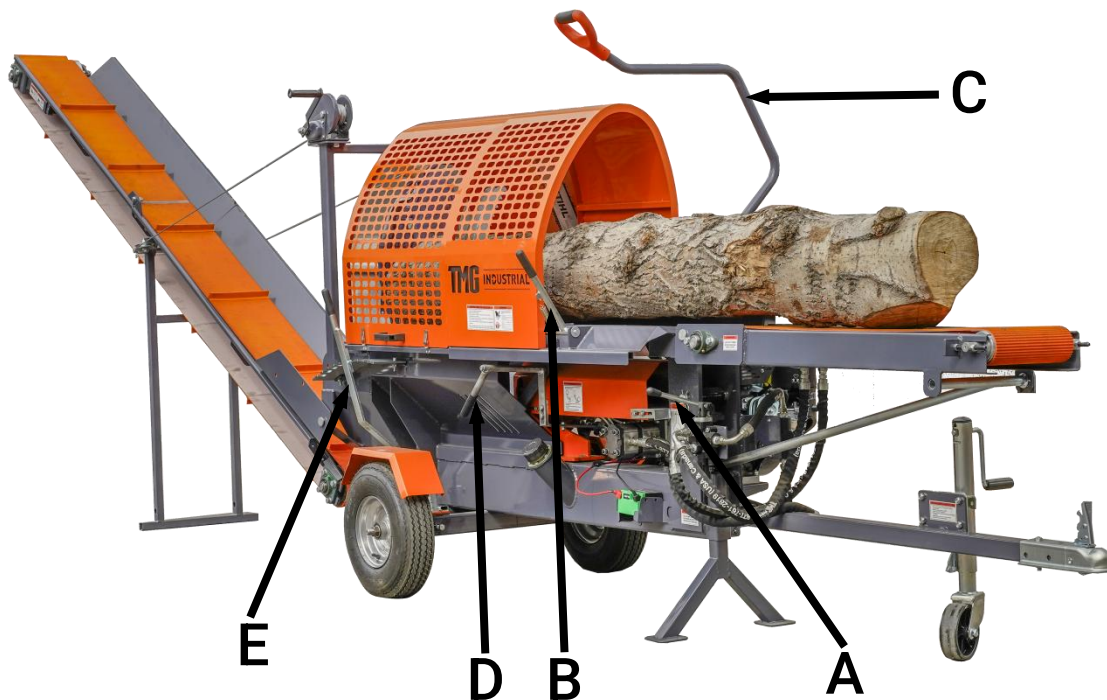

Names and functions of the controls

- A. Feed conveyor control lever
 - The feed conveyor belt rotates forward by moving the lever to the down.
- B. Wood gripper control lever
- C. Cutting control lever
 - When the control lever is depressed, the chainsaw begins to turn and cut the wood. When the cutting is complete, the control lever is lifted to the original position, the chainsaw stops turning and the cutting is finished.
- D. Splitting control lever.
 - Push handle downward, force ram moves forward to clear fire wood.
 - Force ram returns automatically when it reaches the split point.
 - Push handle upward, force ram retracts back.
- E. Height adjustment of the splitting knife.



Before the actual operation of the machine, a test run and functional test must be carried out. Both the test run and testing can only be performed by a person who has studied the machine's manual.



Before the test run, all of the components of the firewood processor must be checked. If any faults or wear and tear that may affect the safe use of the machine are discovered, the processor must not be used until the faulty or worn component is replaced and safe use can be ensured.

Before using the machine, the operator must ensure that:

- The machine has not sustained any damage.
- The machine's operating environment is in accordance with Section 1.4.
- The machine is positioned on a solid foundation.
- No unauthorised persons are within the machine's danger zone.
- All guards and safety devices are in place and functional.
- Opening the splitting and cutting guard stops the machine's hazardous functions.

- The hydraulic hoses and pipes are undamaged. The pipes must be replaced if there is a tear in the hoses or pipes, if they leak, or if the surface layer of the hydraulic hose has worn all the way down to the supporting weave.
- The machine does not leak oil.
- The machine functions properly.
- The emergency stop switch works properly.

Note! Do not use the machine if the requirements listed above are not met!

4.2 PERFORMING A TEST RUN ON THE MACHINE

1. Check that the guard for the firewood processor's splitting section is down.
2. Check that the input and output conveyors are in the operating position.
3. Ensure that the splitting groove is empty. emergency stop switch works properly
4. Make sure that you are familiar with the functions of the machine's controls. If necessary, refer to Section 3.1.
5. Start the engine.
6. Press down the control lever C, the chain saw starts to rotate, press down to the lowest, observe the chain saw rotation, check that the bottom of the chain saw is below the saw platform.
7. Start the splitting motion by pushing up lever D. The splitting beam must move forward by pushing the lever up, and must stop immediately when the lever is returned to the initial position. The splitting beam must move backwards by pulling the lever down, and must stop immediately when the lever is returned to the initial position.
8. Do the following to ensure that the saw chain lubrication functions automatically:
 - a. Use lever C to perform a few sawing motions without any actual logs.
 - b. Turn off the machine and disconnect it from the power source.
 - c. Open the guard and see if the saw chain has been supplied with oil.

Note! In cold weather, the saw valve shaft maybe sluggish at first, which means that the saw bar must be driven to the bottom position a couple of times for the saw chain to run.

10. Move the splitting beam forward and stop it by opening the cradle guard of the splitting section.
11. Ensure that the splitting beam moves backwards by push upward lever D.
12. Test run the feed motion of the input conveyor by press lever A to the down.
13. Visually check that the output conveyor runs at normal speed.
14. Ensure that the splitting motion or saw chain cannot be activated with the guard open.

If a fault occurs during the test run, determine the cause of the fault and take remedial action as deemed necessary. The machine must be shutdown and disconnected from the power source for the duration of both the diagnostics and repairs.

Note! Do not leave a running machine unsupervised!

4.3 WOOD FEEDING, CUTTING AND SPLITTING

The input conveyor belt or feed roller feeds the wood to be processed into the machine. Feed wood into the machine using control lever A.

When feeding wood into the machine, make sure that it does not present a risk of your clothes, hands or other parts getting caught in the machine, such as due to the shape of the log. Do not use your hand to guide the log into the cutting section. Adjust the measuring device to the desired measurement.

1. Choose the log to process. Note that the maximum log diameter is 38 cm. The knottiness and shape of the log can increase the diameter.
2. The input conveyor belt can be driven forward by press lever A to the down, especially when the log is further away from the cutting section and a longer and continuous feed motion is required.
3. Once the log stops for cutting in the mechanical measuring device, lock the login place with the wood gripper by pressing down handle B.
4. Cut the log by pulling down lever C, which activates the saw chain and lowers the saw bar. After sawing through the wood, return the saw bar to the upper position by pushing up lever C.

5. Pulling down lever D, this moves the splitting beam forwards and splits the log.
6. Simultaneously, press lever A to the down, push log into cutting chamber for next cycle operation.

Re-splitting or splitting without cutting

Raise the guard of the cutting and splitting section.

Place the log you want to split in the splitting groove.

Close the guard of the cutting and splitting section.

Move the splitting beam forwards for the desired length by press down lever D and return the splitting beam backwards by push up lever D.

The above procedure can be used to split wood without cutting it.

Note! Placing logs directly on the input table with a loader is strictly prohibited.

Note! Ensure that the log's centre of gravity stays on the conveyor.

Sawing the last log

When sawing wood, the second to last piece should be saw in such away that the remaining piece is of a sufficient length. This ensures that the log will stay firmly under the wood gripper and that the sawing will be steady and safe.

4.4 USING THE DISCHARGE CONVEYOR

The firewood processor's discharge conveyor belt is driven by a hydraulic motor.

The maximum operating angle for the discharge conveyor is 40°.

The maximum angle is indicated on the label and the instructions attached to the discharge conveyor.



If the conveyor is jammed for any reason, the machine must be shutdown before removing the cause. There must be at least 50 cm between the end of the output conveyor and the pile of processed firewood.

4.5 AFTER USE

1. After you have finished making firewood, stop the output conveyor, shutdown the machine and remove the firewood from the splitting groove and conveyor.
2. Ensure that the machine has not been damaged.
3. Place the output conveyor into a position that allows the conveyor and firewood processor to be moved safely off the processed firewood.
4. Clean the machine.

If you will not be using the firewood processor for a while, do the following:

5. As necessary, carefully move it to a location where you can place the input and output conveyors as well as the working platform into their transport and storage positions.
6. Place the conveyors into the transport and storage position.
7. Clean the machine and carryout any maintenance.
8. Store the machine according to the instructions in Section 4.12.

MAINTENANCE

The machine must be disconnected from its power source before maintenance, adjustment, replacement or cleaning procedures. Only use spare parts that are supplied by the manufacturer or your retailer. If the guards of the machine have to be removed for maintenance, they must always be reattached before activating the machine. After maintenance and adjustment measures, a test run must be carried out on the machine, according to the instructions in Section 3.3.

5.1 DISCONNECTING THE MACHINE FROM ITS POWER SOURCE

Ensuring that the machine is inactive

Once you have disconnected the machine from its power source, always ensure that the machine is completely inactive before performing any other measures!

5.2 ADJUSTING THE LOG LENGTH

The firewood processor is equipped with a mechanical log measuring device with an incremented adjustment value of 10 to 60 cm.

1. Turnoff the machine, disconnect it from any power source, and open the protective cover of the machine.
2. Loosen the retaining bolts, then set the wood limiter in the splitting section to the desired length.
3. Re-tighten the retaining bolt.

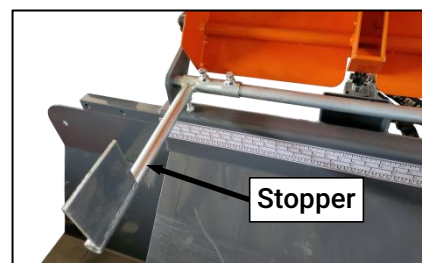

5.3 HEIGHT ADJUSTMENT OF THE SPLITTING KNIFE

The splitting knife can be controlled mechanically by moving control lever E up or down. The splitting knife can be raised by moving lever E to the right and vice versa. Logs should always be as centred as possible when passing the knife, in order to keep the size of the firewood consistent.

The knife can be driven to the lowest position in one go by raising the knife and clearing the space under the knife of firewood. The machine must be shutdown and disconnected from its power source for the duration of the cleaning.



5.4 REPLACING THE SPLITTING KNIFE

 Exercise extreme caution when handling the knife, and wear protective gloves.

1. Turnoff the machine and disconnect it from its power source.
2. Remove any firewood under the splitting knife and lower it to the lowest position using lever E
3. Open the guard and lift the splitting knife out of its slot.

Install a new splitting knife by reversing the above steps.

5.5 ADJUSTING THE TIGHTNESS AND ALIGNMENT OF THE DISCHARGE CONVEYOR BELT

The tightness and alignment of the discharge conveyor belt can be adjusted using T-screw. Loosen adjustment T-screw on the side you wish the belt to run.

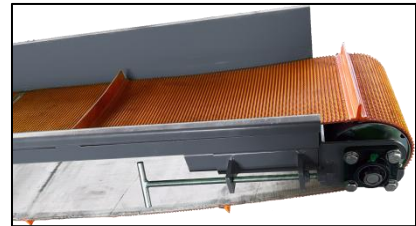

5.6 CUTTING BLADE AND DRIVE END

If the cutting blade of the machine does not penetrate the wood properly or the cut is skewed, the saw chain is most likely blunt. It is a good idea to keep a replacement chain handy, so that you do not need to interrupt your work to sharpen the chain.

Replacing and tightening the saw chain

Replace the saw chain as follows:

1. Turnoff the machine and disconnect it from its power source.
2. Open the guard.
3. Loosen saw bar bolts A.
4. Fully loosen adjustment screw B for saw chain tension.
5. Remove the old saw chain.
6. Install the new saw chain and ensure that the cutting teeth come first in relation to the rotating direction.
7. Lift the saw bar from the front section to tighten the chain as you are attaching the bolts.
8. Use adjustment screw B to tighten the chain and tighten fastening bolts A.

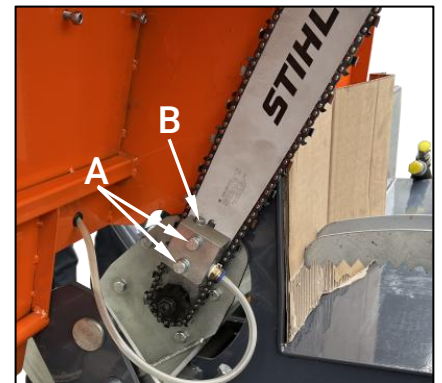

To check the tension of the saw chain, wear protective gloves and pull the lower edge of the chain. The tension is correct if you can pullout three to four teeth of the chain into full view by applying moderate force.

Note! Use protective gloves when handling the saw!

Replacing the saw bar

Replace the saw bar as follows:

1. Remove the saw chain according to steps 1-5 of Section 4.6 "Replacing and tightening the saw chain".
2. Remove the saw bar bolts (2 pcs) and remove fastening plate A
3. Remove the saw bar from the groove.
4. Place the new bar against gearwheel B (Figure 27), twist it into the groove and loosely attach the saw bar bolts and fastening plate A.
5. Attach and tighten the saw chain according to steps 6-8 in Section 4.6 "Replacing and tightening the saw chain".

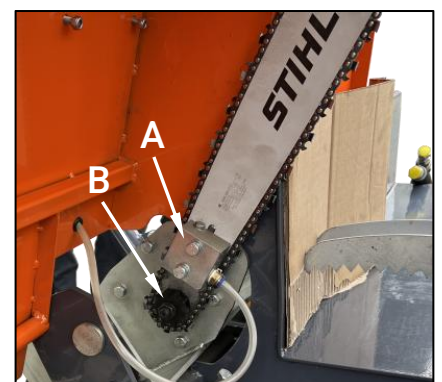

5.7 CHANGING THE HYDRAULIC OIL

Change the hydraulic oil of the firewood processor as follows:

1. Turnoff the machine and disconnect it from its power sources.
2. Open filler cap A of the hydraulic oil tank (this will allow the oil to drain more easily).
3. Open drain plug B and drain the oil into a suitable container.
4. Tighten plug B firmly, and fill the tank with fresh oil (approx. 20 l).

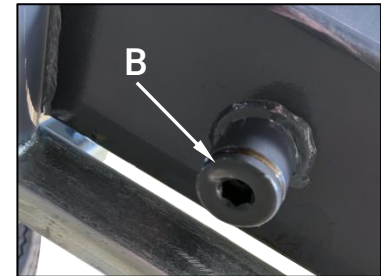
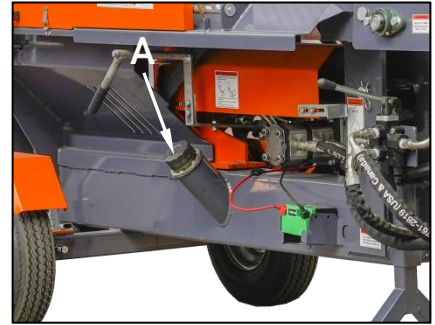

5.8 CONVEYOR MAINTENANCE

Replacing and tightening the feed conveyor belt

Replace the feed conveyor belt as follows:

1. Turn off the machine and disconnect it from its power sources.
2. Raise and lock the input conveyor into the transport position.
3. Move the belt joint to a suitable height.
4. Disconnect the joint by using pliers, for example, to pullout pin A that holds the joint together.
5. Remove the old belt.
6. Insert the new belt from the side of the input conveyor's drive roller through opening B, until you can pull the belt out from other end.
7. Connect the joint by inserting pin A into the joint.
8. Turn the conveyor back to the operating position and tighten the belt. Use adjustment nuts C to adjust the belt.

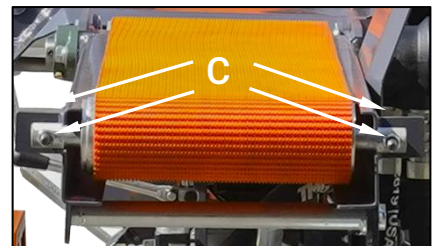
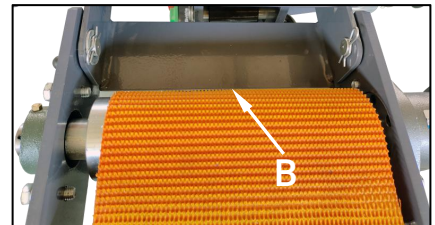
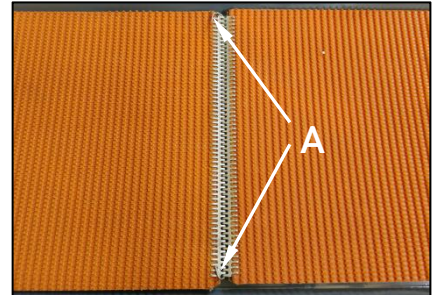

The belt is at the correct tension when its middle section is raised approx. 5 cm when the conveyor is in the operating position. An excessively tight belt may be damaged more easily, and it places unnecessary strain on the conveyor bearings.

Replacing and tightening the discharge conveyor belt

The instructions for tightening and aligning the discharge conveyor are presented in Section 4.5. Replace the discharge conveyor belt as follows:

1. Turn off the machine and disconnect it from its power sources.
2. Pullout the pin locking the conveyor in place, and lower the conveyor to the ground.
3. Move the belt joint to the beginning of the conveyor.
4. Fold the conveyor, but do not place the belt support in the transport position. This will allow the belt to hang loose.
5. Disconnect the joint by opening the bolts.
6. Remove the old belt.
7. First, insert the new belt under the folded conveyor (bottom opening) from the end of the convey- or with the plates facing downwards. Feed the belt in until you can pull it out from the other end of the conveyor. Pullout a length of approx. 60 cm.
8. Push the other end of the belt into the upper section of the folded conveyor (top opening) from the end of the conveyor. Feed it in until you can connect the joint.
9. Pull the excess belt to the start of the conveyor.
10. Open the conveyor to the operating position, and tighten and adjust the belt.

The belt is at the correct tension when its middle section is raised approx. 15 cm when the conveyor is in the operating position. An excessively tight belt maybe damaged more easily, and it places unnecessary strain on the conveyor bearings.

5.9 LUBRICATION

All of the firewood processor's lubrication points, which require Vaseline. There are four lubrication points.

1. Grease nipple of the input conveyor drive roller .
2. Nipples (3 pcs) of the output conveyor's drive roller.

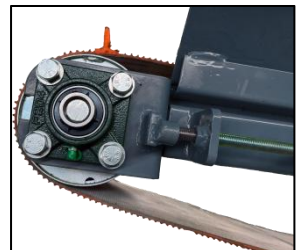
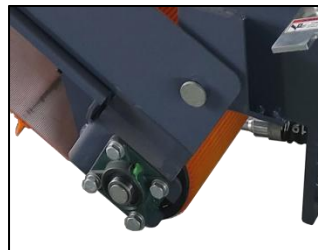

5.10 WASHING AND CLEANING

Loose debris and sawdust can be cleaned from the machine with pressurised air, for example. The machine can also be washed with a pressure washer, as long as the water jet is not aimed directly at the bearings or electrical equipment.

Always ensure that the machine and the working area are sufficiently clean during operation. The machine must always be cleaned after use. Clean the machine as necessary, and always before storing the machine for a prolonged time. After washing, the machine must be lubricated according to the instructions in Section 4.9.

5.11 STORAGE

The firewood processor must be stored on a level and solid foundation. Although the machine is intended for outdoor use, it should be covered and stored in a sheltered location or indoors. Before prolonged storage, the machine must first be cleaned, then washed according to Section 4.11 and lubricated according to Section 4.9.

5.12 MAINTENANCE TABLE

Target	Task	Daily	Interval 50 h	Interval 500 h	Sub-stance/accessory item
Hydraulic oil Normal conditions	Check 1st change Subsequent	X	X	X	Amount approx. 20 l Such as Teboil S 32
Oil filter	Always when changing oil				
Cutting blade	Sharpen as necessary				0.325" 66/1.5
Machine	Clean Wash	X			
Emergency stop switch	Clean/check visually	X			
Winch and strap	Check	X			

FAILURES AND REMEDIAL MEASURES

Cause-effect table for failures and their removal

Failure	Cause	Remedial measure
The splitting force is insufficient for splitting the wood.	<p>The relief valve of the splitting and cutting valve has been tightened excessively.</p> <p>The seal of the splitting cylinder piston is leaking.</p>	<p>Clean and open the relief valve slightly by tightening the hex socket screw. First ask for additional instructions from your machine's retailer!</p> <p>Change the cylinder seals.</p>
The feed conveyor belt does not move.	The belt is too loose.	Tighten the belt in accordance with the instructions in Section 4.9 "Replacing and tightening the input conveyor belt".
The discharge conveyor does not move.	<p>The belt is too loose.</p> <p>The discharge conveyor's relief valve is leaking.</p>	<p>Tighten the belt in accordance with the instructions in Section 4.5 "Replacing and tightening the output conveyor belt".</p> <p>Clean the relief valve or replace it as necessary.</p>
The cutting motion does not fully cut the log.	The path of the saw bar is incorrectly adjusted.	Lower the path of the saw bar.
The chainsaw does not properly penetrate the wood.	<p>The chainsaw is dull or veers to the side (due to uneven sharpness).</p> <p>The saw bar is crooked.</p>	<p>Sharpen or replace the saw chain.</p> <p>File the bar to make it straight.</p>

6.1 JAMMING OF THE CUTTING BLADE

If the cutting blade gets jammed in the log, stop sawing and try again on another section of the log. If the cut is **misaligned because the bar drags to one side, the sharpness of the saw chain must be checked**. A chain that is not evenly sharp will always drag towards the blunter side, which will make cutting a thick log impossible. Moreover, sawing with an evenly dull chain is inefficient, and the chain must be sharpened or replaced (see Section 4.6).

6.2 JAMMING OF THE WOOD ON THE SPLITTING KNIFE

If a piece of wood gets jammed on the splitting knife in a situation where the splitting force is insufficient to push the piece past the knife despite several attempts to do so, do the following:

Return the splitting cylinder to the initial position with lever D .

Ensure that the log to be split does not exceed the maximum allowable dimensions.

Lift the splitting knife to the highest possible position with lever E and activate the splitting.

If necessary, cut a sufficiently thick piece of wood (approx. 10 cm), place it into the splitting groove behind the jammed piece, and activate the splitting process. The new piece will then push the bottom part of the jammed piece past the knife. Lower the knife by approx. 5 cm and repeat step 3. Repeat step 4 until the jammed wood has passed the knife, piece by piece.

HYDRAULICS DIAGRAM

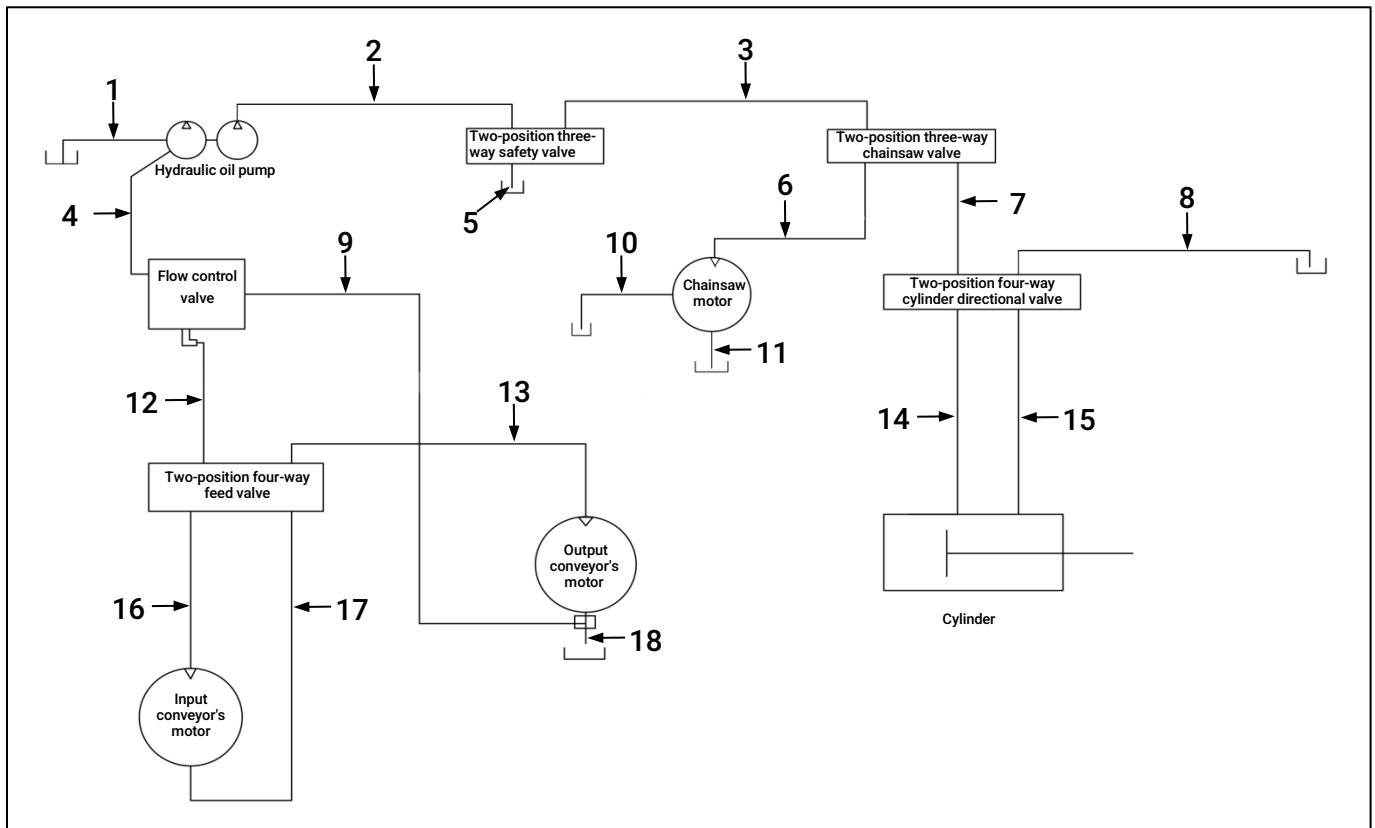

Hydraulic Hose List

PART NO.	DESCRIPTION	Connector Information
1	Oil inlet hydraulic hose 5/8"x14"	90 degree bend joint M27x1.5
2	Safety valve inlet hydraulic hose 1/2"x51"	90 degree bend joint M22x1.5
3	Chainsaw valve inlet hydraulic hose 1/2"x40"	90 degree bend joint M22x1.5
4	Flow control valve inlet hydraulic hose 1/2"x16"	Straight connection M22x1.5
5	Safety valve return hydraulic hose 1/2"x20"	90 degree bend joint, straight connection M22x1.5
6	Chainsaw inlet hydraulic hose 1/2"x51"	90 degree bend joint M22x1.5
7	Cylinder directional valve inlet hydraulic hose 1/2"x16"	90 degree bend joint, straight connection M22x1.5
8	Cylinder directional valve return hydraulic hose 1/2"x24"	Straight connection M22x1.5
9	Flow control valve return hydraulic hose 1/2"x87"	90 degree bend joint, straight connection M22x1.5
10	Chainsaw return hydraulic hose 3/8"x43"	90 degree bend joint, straight connection M18x1.5
11	Chainsaw return hydraulic hose 1/2"x36"	Straight connection M27x1.5
12	Feed valve inlet hydraulic hose 1/2"x12"	90 degree bend joint M22x1.5
13	Output conveyor's motor inlet hydraulic hose 1/2"x6"	90 degree bend joint, straight connection M22x1.5
14	Cylinder inlet hydraulic hose 1/2"x33"	90 degree bend joint, straight connection M27x1.5
15	Cylinder return hydraulic hose 1/2"x24"	90 degree bend joint, straight connection M27x1.5
16	Input conveyor's motor inlet hydraulic hose 1/2"x32"	90 degree bend joint, straight connection M22x1.5
17	Input conveyor's motor return hydraulic hose 1/2"x32"	90 degree bend joint, straight connection M22x1.5
18	Output conveyor's motor return hydraulic hose 1/2"x36"	Straight connection M22x1.5

EXPLODED VIEW

8.1 MAIN EXPLODED DRAWING

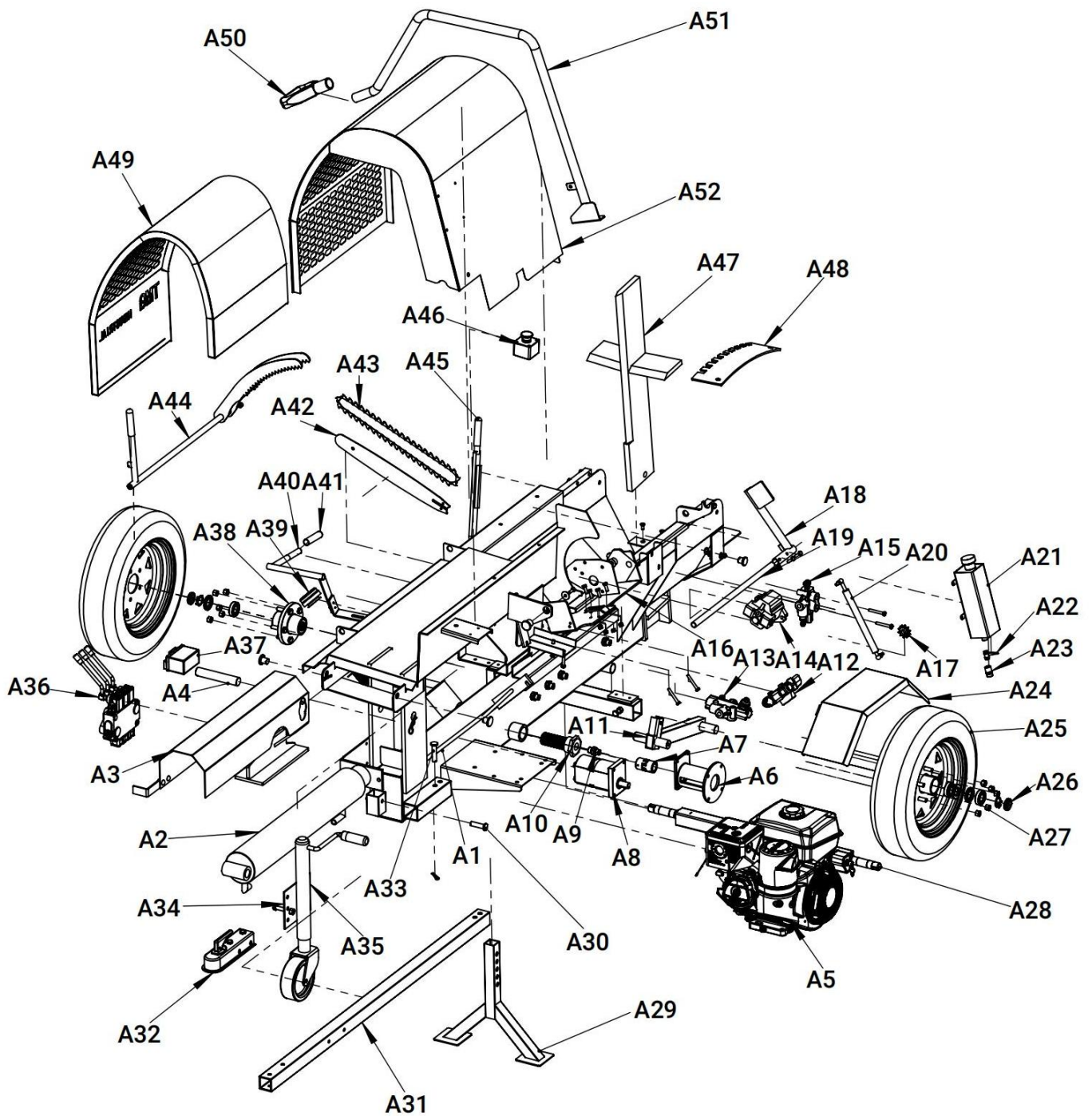

Main Parts List

PART NO.	DESCRIPTION	QTY	PART NO.	DESCRIPTION	QTY
A1	Main support	1	A27	Wheel hub bearing	4
A2	Hydraulic cylinder 4"x24"	1	A28	Wheel axle	1
A3	Safety cover of hydraulic cylinder	1	A29	Tripod leg	1
A4	Pin of hydraulic cylinder Ø30x6.8"	1	A30	Pin of tripod leg	1
A5	Engine Kohler CH440	1	A31	Towing bar	1
A6	Oil pump support	1	A32	Trailer coupler 2"	1
A7	Directly coupling	1	A33	Trailer pin	1
A8	Hydraulic pump	1	A34	Trailer jack support	1
A9	Oil inlet connection	1	A35	Trailer jack	1
A10	Feed the oil filter	1	A36	The control valve of input conveyor	1
A11	Swivel bar	1	A37	Battery 12V,3AH	1
A12	The control valve of hydraulic cylinder	1	A38	Wheel hub	2
A13	The control valve of chainsaw	1	A39	Cover of hydraulic tank	1
A14	Motor of chainsaw	1	A40	Adjusting rod	1
A15	Safety valve	1	A41	Adjusting rod cover	1
A16	Motor support	1	A42	Chainsaw bar 18"	1
A17	Chain wheel	1	A43	Chainsaw blade	1
A18	Stopper	1	A44	Wood gripper	1
A19	Stopper sliding rail	1	A45	Handle of wood gripper	1
A20	Chainsaw restoring lever	1	A46	Emergency stop switch	1
A21	Chainsaw lubrication oil tank	1	A47	4-way wedge	1
A22	Lubrication oil tank switch	1	A48	Wedge adjustment plate	1
A23	Lubrication oil tank connection	1	A49	Saw guard	1
A24	Mudguard	2	A50	Operating lever sleeve	1
A25	Wheel	2	A51	Handle of chainsaw	1
A26	Self-locking nut M27x1.5	2	A52	Splitter guard	1

8.2 FEED CONVEYOR EXPLODED DRAWING

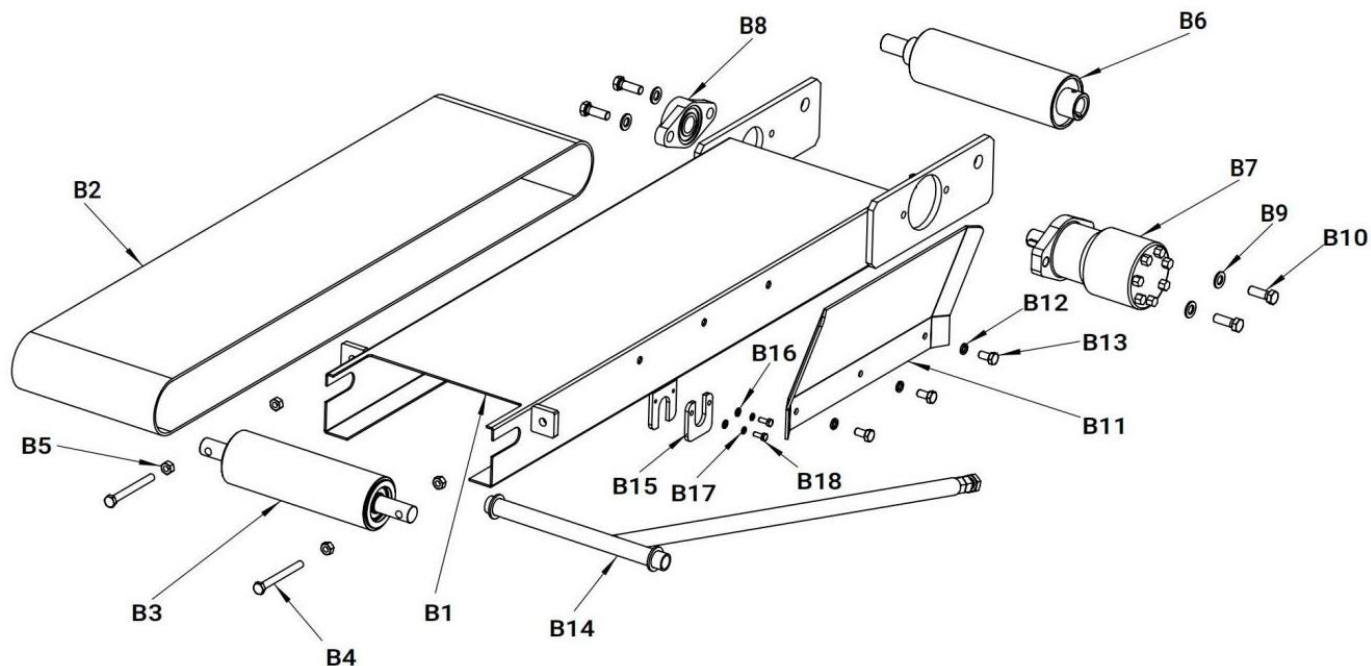

Feed Conveyor Parts List

PART NO.	DESCRIPTION	QTY	PART NO.	DESCRIPTION	QTY
B1	Feed rack support	1	B10	Hexagon bolts M12x35	4
B2	Feed conveyor belt 250X350	1	B11	Feed deflector	1
B3	Tail pulley weld assy	1	B12	Spring washer Ø10x2	3
B4	Adjustable bolt from tail pulley M10x70	2	B13	Hexagon bolts M10x20	3
B5	Hexagon lock nut M10	4	B14	Feed rack support rod	1
B6	Driver pulley weld assy	1	B15	Support plate	1
B7	Hydraulic motor R200	1	B16	Plain washer Ø6	1
B8	Bearing housing UCFL205	1	B17	Spring washer Ø6	1
B9	Plain washer Ø12	4	B18	Hexagon bolts M6x16	1

8.3 DISCHARGE CONVEYOR EXPLODED DRAWING

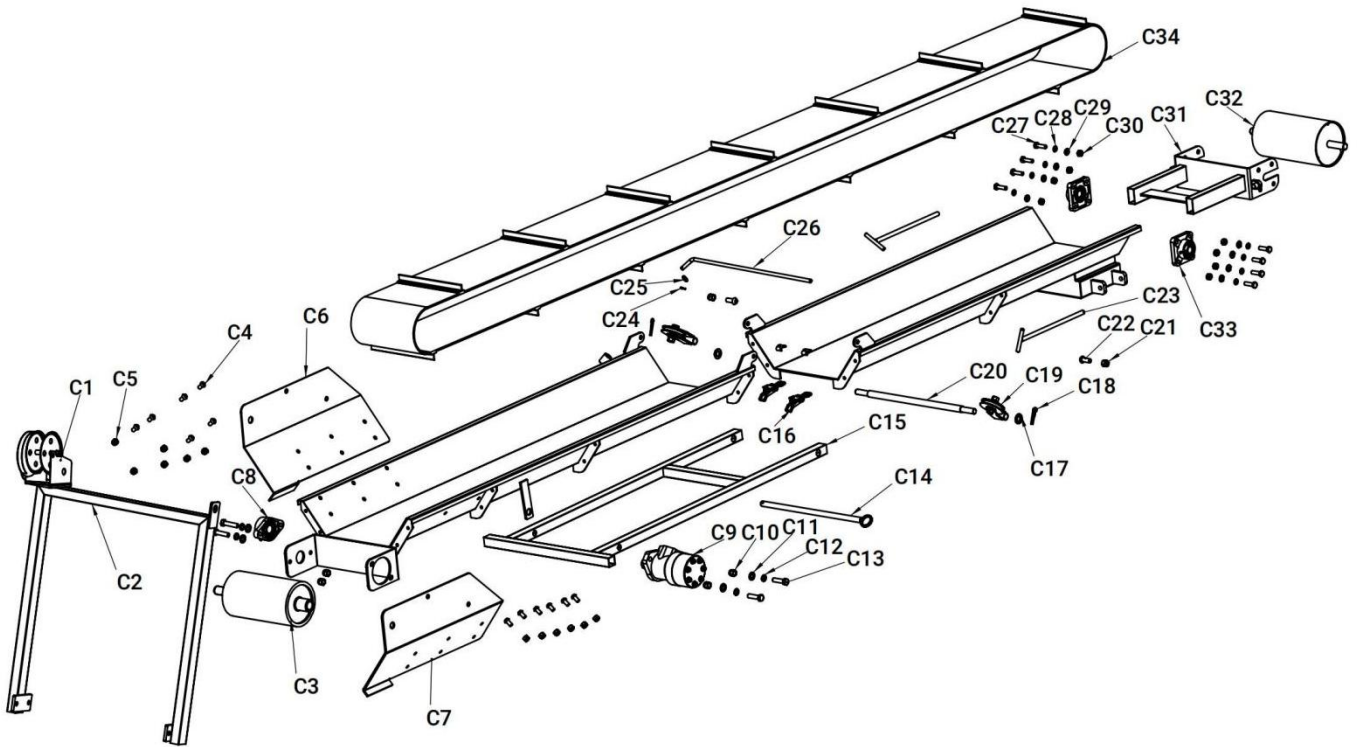

Discharge Conveyor Parts List

PART NO.	DESCRIPTION	QTY	PART NO.	DESCRIPTION	QTY
C1	Hand winch 1200lbs	1	C18	R-pin	2
C2	Winch support	1	C19	Lifting pulley	2
C3	Driver pulley weld assy	2	C20	Support leg shaft	1
C4	Hex socket flat round head screw M10x20	12	C21	Hexagon bolts M10x30	2
C5	Self-locking nut M10	12	C22	Hexagon lock nut M10	2
C6	Fixing plate left	1	C23	T adjustable bolts	2
C7	Fixing plate right	1	C24	Split cotter Ø3.2x16	1
C8	Driver pulley bearing housing UCFL205	1	C25	Plain washer Ø10	1
C9	Hydraulic motor R200	1	C26	Conveyor belt support rod	1
C10	Hexagon nut M12	4	C27	Hexagon bolts M10x35	8
C11	Plain washer Ø12	4	C28	Spring washer Ø10	8
C12	Spring washer Ø12	4	C29	Plain washer Ø10	8
C13	Hexagon bolts M12x45	4	C30	Hexagon nut M10	8
C14	Support leg fixed shaft	1	C31	Tail pulley support	1
C15	Support leg	1	C32	Tail pulley weld assy	1
C16	Adjustable buckle	2	C33	Bearing housing UCFU204	2
C17	Plain washer Ø16	2	C34	Discharge conveyor belt 250X6800	1

WARRANTY INFORMATION:

Please refer to our website for detailed warranty conditions and coverage.

For the most up-to-date and comprehensive warranty information, visit www.tmgindustrial.com