

FOTILE

A BREATH OF FRESH ENGINEERING®



U.S.
DESIGN
PATENT

SLANT VENT SERIES RANGE HOODS



Sold in over **30** countries around the world,
and chosen by **30 million** families



Entered the Canada market in **2015**,
focusing on healthy kitchen solutions



More than **2,500** service technicians
in the North America



Earned **10K+** kitchen appliance patents
Global Smart Home Invention Patent **TOP100**



Member of HVI, the most
authoritative and credible
institution in North America



Powerful Smoke Extraction

Close proximity to cooking area, wide
smoke inlet with 6-7.2 sq.ft. coverage area



Efficient DC Motors*

Provide extraordinary power and
smooth ventilation



Dual Centrifugal Blowers

Extract smoke quickly and prevent it
from escaping



Motion Activation*

Convenient hand wave ON/OFF operation



Easy and Fast Installations

Wall-mount or under-cabinet



98% Odor Reduction Rate

95% Grease Separation Rate

* Prestige Series Only

INDUSTRY LEADING WARRANTY:

PARTS

5-YEAR (LIMITED)

LABOR

2-YEAR

MOTOR

LIFETIME GUARANTEE
(LABOR NOT INCLUDED)

Toll Free: 844-315-0315

Address: 8365 Woodbine Ave,
Markham, L3R2P4

Official Website: ca.fotileglobal.com

Email: service@fotileca.com



Canada WeChat
Official Account



Canada
WeChat Service



	Prestige Series		Classic Series		Core Series
Width	30in		36in		30in
Model Options	JQG7507-Y	JQG7505 / JQG7505-W	JQG9006 / JQG9006-W	JQG7501 / JQG7501.G	JQG9001
Color Options	●	● ●	● ●	● ●	● ●
Max. EQUIV. CFM	1100		1000		850
Operation	Motion + Touch Screen + Sync Connect*		Motion + Touch Screen		Touch Screen
Delay Shutoff	5min.		2min.		/
Panel Material	MOONSHADOW AG Glass		Black Tempered Glass		Black Tempered Glass
Motor	Dual DC Motors		Dual AC Motors		Dual AC Motors
Max. Static Pressure	540Pa		400Pa		400Pa
Number of Speed Settings	3 + Stir-Fry Mode		3		3
Capture Shield	Automatically Opens to 90°		Automatically Opens to 90°		Fixed Open at 90°
Easy to Clean	Oversized Oil Cup; Dishwasher Safe Oil Filter		Oversized Oil Cup; Dishwasher Safe Oil Filter		Oversized Oil Cup; Dishwasher Safe Oil Filter
Min. Noise Level	38dB		39dB		39dB

*This feature is available with any FOTILE Cooktop that features Sync Connect.

5-year limited warranty

2-year full warranty, 5-year limited warranty on all parts.
Lifetime warranty on motor.



JQG7501



JQG7505-W



JQG7507-Y



JQG7502.G

Unit: in

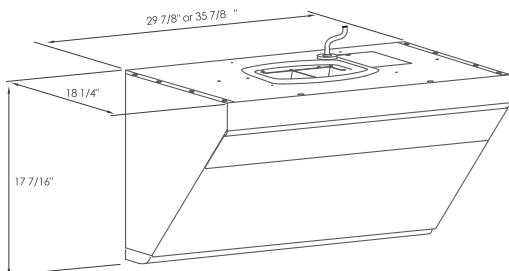

▲ Product Dimensions

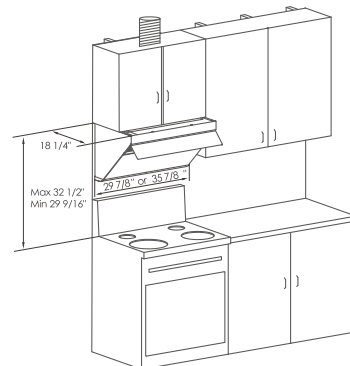

▲ Installation Dimensions

* Product Width: 29 7/8 inch = JQG7505/JQG7505-W/JQG7507-Y/JQG7501/JQG7501.G/JQG7502/JQG7502.G
 Product Width: 35 7/8 inch = JQG9001/JQG9006/JQG9006-W