

FOTILE



A BREATH OF FRESH ENGINEERING™

WHY FOTILE

Trustworthy Brand

- Sold in over 20 countries around the world, and chosen by 10,000+ families daily.
- FOTILE side-draft range hood is the best-selling range hood for 6 consecutive years.
- First Chinese kitchen appliance manufacturer to achieve a revenue of more than \$1.5 billion.
- 3500 technicians in 50 states ensures timely and professional service.
- Owner of nearly 3,000 kitchen appliance patents, with 400 being invention patents.
- Leader of side-draft range hoods with more than 10 years of experience.
- Leading the research and development of International Standards for Range Hoods.

Effective Products

- Innovative side-draft design is closer to the cooktop for faster & more powerful ventilation.
- Covers over 6sq.ft of cooktop area, effective for 4 and 5 burner cooktops & ranges.
- Efficient DC motor with extraordinary power and lower noise.
- Dual centrifugal blowers to extract the smoke quickly, preventing any cooking smoke from escaping.
- Motion Detection Operation - Wave to turn On / Off.
- Easy and fast wall-mounted or under-cabinet installation.
- Satisfaction rate nearly 95%, leading in the industry.



Member of HVI, the most authoritative and credible institution in North America



reddot



product design award



Intertek

Toll Free: +1 844-315-0315

Address: 8365 Woodbine ave, Suite 113, Markham, ON L3R 2P4

Official Website: ca.fotileglobal.com

Email: info@fotileca.com



WeChat Service



YouTube



fotile_canada



	05 series High-Tech	01 series Best Selling	02 series Value
Motor	Dual DC motors(Powerful and Quiet)	Dual AC motors	Dual AC motors
Highest Static Pressure	540Pa Smooth ventilation	400Pa	400Pa
Operation	Motion Detection + Touch screen	Touch Screen	Buttons
Power Level	Boost / High & Middle & Low	High & Middle & Low	High & Middle & Low
Capture Shield	Automatic	Automatic	Fixed open
Auto Delay	2 minutes	2 minutes	/
Easy to Clean	Tempered glass; Detachable and foldable oil filter	Tempered glass; Detachable and foldable oil filter	Tempered glass; Detachable and foldable oil filter
Color	Onyx Black	Onyx Black / Silver Grey	Onyx Black / Silver Grey
Minimum Noise	39dB	40dB	40dB
Length	30in	30in/36in	30in
Model Option	JQG7505	JQG9001; JQG7501; JQG7501.G	JQG7502; JQG7502.G

3-year limited warranty

1 years full warranty. 3 years limited warranty on all parts.
Life time warranty on motor.



05 series JQG7505 installation example



01 series JQG7501.G installation example

Unit: in

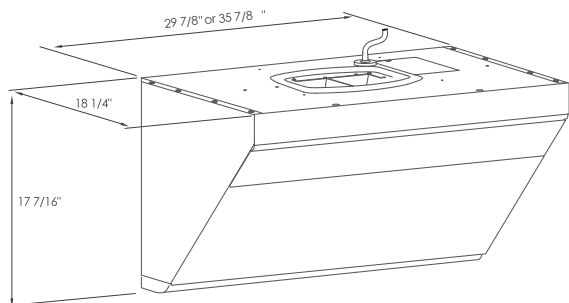

▲ Product Dimensions

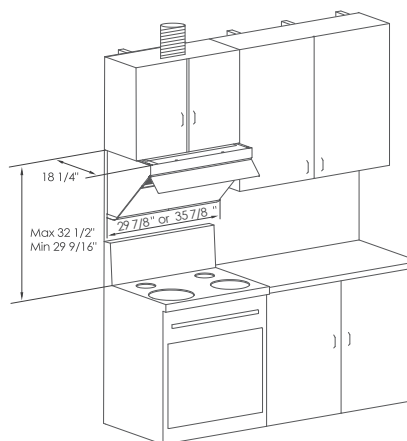

▲ Installation Dimensions