

FOTILE

A BREATH OF FRESH ENGINEERING®



PERIMETER VENT SERIES RANGE HOODS



Sold in over **30** countries around the world,
and chosen by **30 million** families



Entered the Canada market in **2015**,
focusing on healthy kitchen solutions



More than **2,500** service technicians
in the North America



Earned **10K+** kitchen appliance patents
Global Smart Home Invention Patent **TOP100**



Member of HVI, the most authoritative and credible institution in North America



Capture Shield Technology

Extracts smoke quickly and prevents it from escaping



Intelligent Self-Adjusting *

Auto-adjusts speed and height settings based on the volume of smoke and odors in your kitchen



High-Powered DC Motor **

Powerful smoke extraction and smooth ventilation



Self-Clean Function *

High-speed impeller rotation rapidly dispels grease, ensuring thorough cleaning



98% Odor Reduction Rate Achieved



95% Grease Separation Rate Achieved

(Maximum rate achieved in FOTILE range hoods)

* EMG9050 Only ** AC Motor for EMS9026

INDUSTRY LEADING WARRANTY:

PARTS

5-YEAR (LIMITED)

LABOR

2-YEAR

MOTOR

LIFETIME GUARANTEE
(LABOR NOT INCLUDED)

Toll Free: 844-315-0315
Address: 8365 Woodbine Ave unit 113,
Markham, ON L3R 2P4
Official Website: ca.fotileglobal.com
Email: service@fatileca.com



Canada WeChat
Official Account



Canada
WeChat Service

FOTILE

A BREATH OF FRESH ENGINEERING®



	EMG9050 Intelligent Self-Adjusting	EMS9026 Adjustable Capture Shield	EMG7508 Capture Shield Technology	EMS6008-C Capture Shield Technology
Width	36in	36in	30in	24in
Motor	DC Motor	AC Motor	DC Motor	DC Motor
Max. EQUIV. CFM	1300	1000	1200	850
Max. Static Pressure	1000Pa	500Pa	1000Pa	880Pa
Operation	Motion + Touch Screen	Touch Screen	Motion + Touch Screen	Motion + Touch Screen
Number of Speed Settings	2 + Auto Turbo Mode	2 + Auto Turbo Mode	3 + Stir-Fry Mode	3 + Stir-Fry Mode
Capture Shield	Fixed / Intelligent Self-Adjusting	Fixed / Adjustable	Fixed	Fixed
Delay Shutoff	5 min.	2 min.	2 min.	5 min.
Min. Noise Level	34dB	40.5dB	37dB	41dB
Sync Function	Y	N	N	N
Auto Turbo Mode	Y	Y	N	N
Self-Clean Function	Y	N	N	N
Ventilation Type	Ducted	Ducted	Ducted	Ducted

5-year limited warranty

2-year full warranty. 5-year limited warranty on all parts.
Lifetime warranty on motor.



EMG9050



EMS9026



EMG7508



EMS6008-C

Product Dimensions (Unit: in)

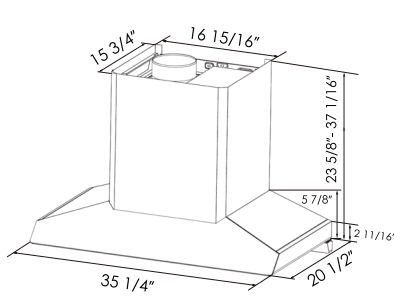

▲ EMG9050

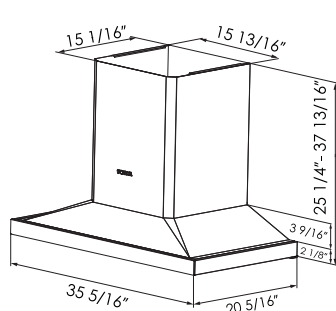

▲ EMS9026

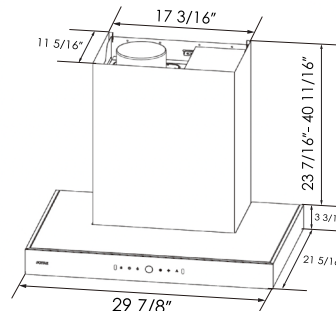

▲ EMG7508

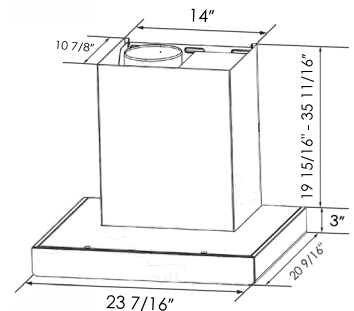

▲ EMS6008-C