

# Memory HiCorder MR8827

Hidekazu Tsukada

Engineering Division 1, Engineering Department

**Abstract**—The Memory HiCorder MR8827, which was designed for use in a broad range of general-purpose applications such as troubleshooting as well as in system applications, is a waveform recorder that provides up to 92 channels of analog and logic input. This paper provides an overview of the product and describes its architecture and features.

## I. INTRODUCTION

Power systems have been growing increasingly complex in recent years. For example, products such as electric vehicles (EVs) and power systems that tie solar power and other environmental energy sources to the grid handle a broad array of electrical signals at voltages ranging from high to minuscule (for example, sensor input) and control signals. As a result, there is demand for instruments that provide a single-device solution for safely measuring such signals along a common time axis.

Meanwhile, in troubleshooting and anomaly-monitoring applications, the more electrical signals can be measured at once, the easier it is to identify the cause of the issue being investigated. There is need for multichannel measuring instruments that are small enough to fit in a system rack for use in monitoring applications and that provide sufficient portability for use in troubleshooting.

The Memory HiCorder MR8827 is a multichannel waveform recorder that satisfies these requirements.

## II. OVERVIEW

The MR8827, which Hioki engineered as a self-contained instrument capable of measuring numerous phenomena and circuits, is designed to serve as a single-instrument solution for observing overall equipment (system) behavior.

For example, if a power system or other complex circuit generates an anomalous signal, technicians must search for the source of the signal by observing signal waveforms before and after the occurrence of the event in question. The more signals they can measure at once, the easier they can pinpoint the cause of the anomaly. Similarly, assessing equipment behavior requires measuring a broad array of signals. To that end, Hioki equipped the MR8827 so that users could easily measure the required signal waveforms, including high- and low-voltage signals, signals with minuscule voltage fluctuations, and current, frequency, logic, and relay control signals, simply by adding the corresponding measurement modules.

In this way, the MR8827 is a waveform recorder that was developed to boost user convenience by offering

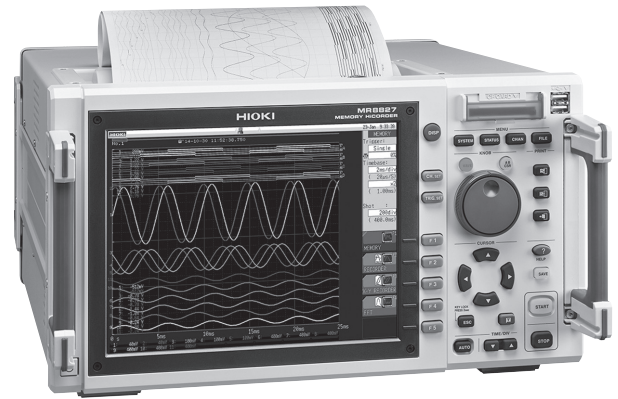

Appearance of the MR8827.

multichannel capability and a range of measurement modules so that it could perform anomaly analysis and verification tasks targeting overall equipment operation and by speeding up those processes.

## III. FEATURES

### A. Simultaneous Measurement of Up to 92 Analog and Digital Channels

The MR8827 provides up to 32 analog channels, and in this configuration it can simultaneously measure a mix of a total of 64 analog and digital channels (32 analog and 32 logic channels).

In addition, users can add logic modules to the MR8827 to enable measurement of a larger number of relay and logic signals from sources such as control panels. Up to 64 such logic signals can be measured at the same time. In this configuration, the instrument can measure 28 analog channels, for a total of 92 analog and digital channels.

### B. Fully Isolated Channels and Simultaneous 20M Sampling

All analog channels are isolated from the instrument's chassis and from each other to ensure safety during high-voltage measurement. In addition, the instrument can simultaneously all channels at a sampling rate of up to 20M.

### C. Extensive Selection of Measurement Modules

The MR8827 can use all input modules that are available as options for the Memory HiCorder MR8847 and MR8740. These modules enable simultaneous measurement of not only voltage, but also current, temperature, and strain.

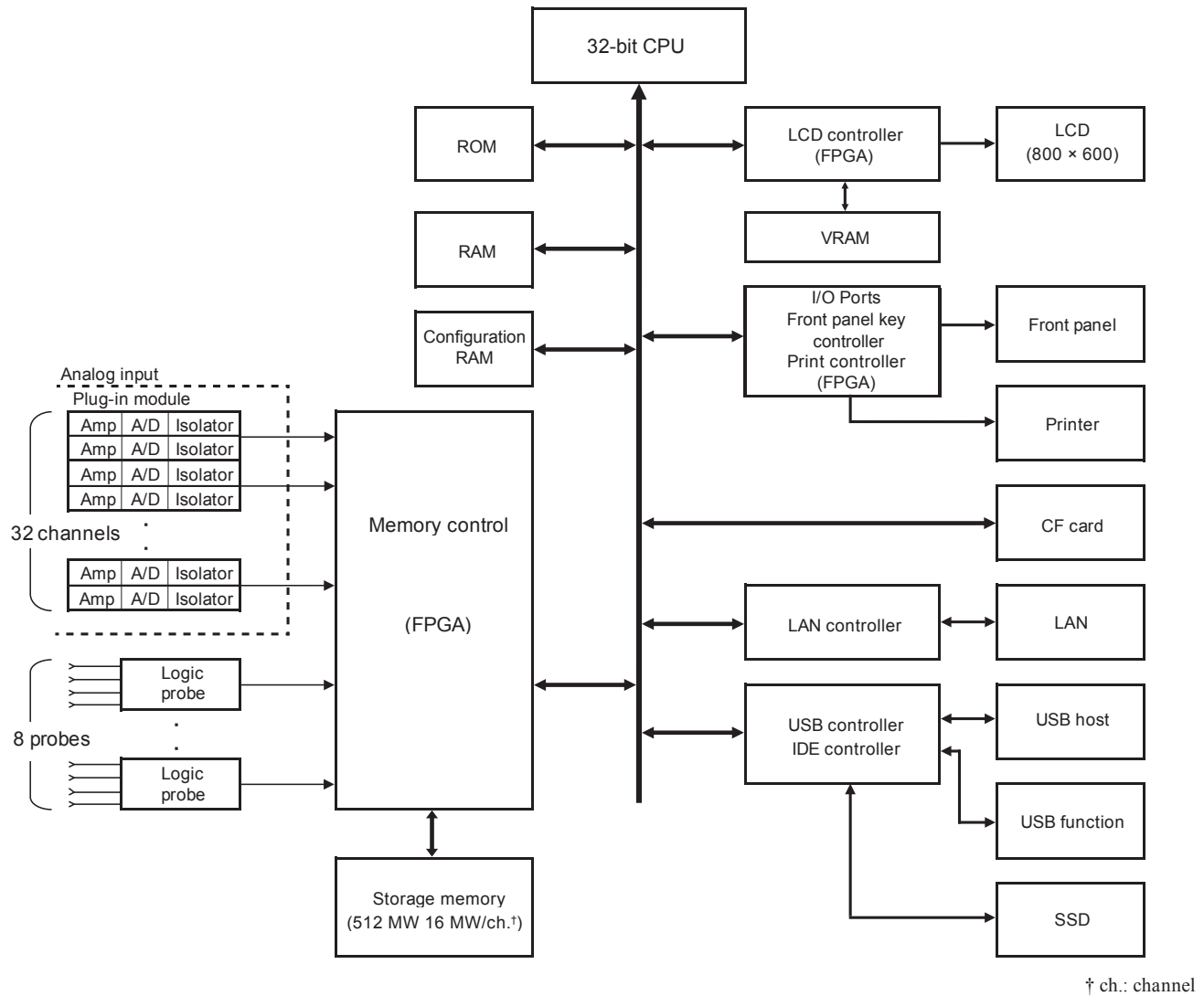

† ch.: channel

Fig. 1. MR8827 block diagram.

TABLE 1 provides a list of compatible measurement modules.

Going forward, Hioki will continue to add new input modules to enable the MR8827 to accommodate a variety of measurement situations.

*D. Printer*

Like the MR8847, the MR8827 incorporates a printer whose design makes it easy to load recording paper. The instrument delivers the same high-speed printing as the MR8847 with a feed speed of 50 mm/s (1.97 inches per second), slashing printing times by half compared to the Memory HiCorder 8826 (a legacy product).

*E. External Storage*

The MR8827 is equipped with a 128 GB solid-state drive (SSD) for internal storage. SSDs provide improved vibration and impact resistance compared to conventional hard disks.

TABLE I. MEASUREMENT MODULES

Measurement target	Name	Sampling	Resolution
Voltage	Analog	20M	12 bits
Voltage	High resolution	1M	16 bits
Voltage	DVM <sup>a</sup>	500	24 bits
Voltage (RMS)	DC/RMS	1M	12 bits
Temperature	Temperature	n/a	16 bits
Frequency, etc.	Frequency	n/a	16 bits
Current	Current	1M	12 bits
Strain	Strain	200k	16 bits
Digital signals	Logic	20M	n/a

<sup>a</sup> DVM: Digital voltmeter

The instrument can also save data on USB flash drives and CompactFlash (CF) cards as external storage media.

### F. Compatibility

The MR8827 is compatible with the MR8847 and MR8740 series. In addition to its ability to use the same modules, the instrument shares screen displays and operability features in an effort to increase convenience and avoid operator confusion. This compatibility extends to communications commands and the loading of measurement data.

## IV. ARCHITECTURE

Fig. 1 provides a block diagram for the MR8827. Like the MR8847, the instrument relies on a 32-bit reduced instruction set computing (RISC) CPU for system control and on a field-programmable gate array (FPGA) for the peripheral circuitry used to implement memory control, the display, and external control.

### A. Peripheral Circuitry

1) *Memory control circuitry*: Memory control circuitry is implemented as an FPGA and consists of a memory control block that arbitrates storage memory, a trigger detection block, and a data processing block that performs calculations.

This FPGA was designed during the development of the Memory HiCorder 8847 so that it could be expanded to 32 analog channels and 32 logic channels. Consequently, it was a simple task to give the MR8827 multichannel capability [1], [2].

2) *LCD control circuitry*: A proprietary display controller in the FPGA implements the instrument's high-speed display.

3) *I/O, printer, and key control circuitry*: This circuitry, which is implemented as FPGA, is identical to that found in the 8847. It serves to control the memory control FPGA's interface and interrupts.

4) *External interfaces*: The USB interface uses a USB controller that complies with the USB 2.0 (High Speed) standard. The MR8827 provides two USB ports, allowing simultaneous use of a mouse and a USB flash drive, which was not possible with the 8847.

The LAN interface supports 10BASE-T/100BASE-T connections. As with the MR8740/MR8741, protocol control is implemented in hardware to enable high-speed operation.

### B. Hardware

1) *Appearance*: Hioki achieved an exceptional level of ease of use under a variety of measurement conditions by using the same compact enclosure for the MR8827 as for the 8826 (a legacy product) and other instruments while simultaneously giving the new product dramatically improved performance. Use of the same form factor as the 8826 is also helpful from the standpoint of accommodating replacement demand. Newly designed handles have been provided on both sides on both the front and rear of the

instrument to facilitate improved operation. The grip portion of each handle features the distinctive blue, Hioki's new corporate color that is called "Product Blue," in order to conform to Hioki's new, standardized look.

2) *Chassis*: Fig. 2 and Fig. 3 provide exploded views of the MR8827's chassis.

The newly designed handles feature an integrated design that has been implemented with insert molding around a metal plate to deliver more than adequate strength while simultaneously protecting the instrument. Use of thermoplastic elastomer (TPE) material, which is pleasing to the touch, on the grip portion of each handle makes the instrument easy to hold. Use of a main frame made of aluminum on the bottom of the chassis with newly designed side panels made of extrusion-molded aluminum on both sides increases rigidity while reducing weight. Each of the instrument's printed circuit boards is connected primarily by means of a modular connector in order to reduce the amount of wiring in the product. Measurement modules are surrounded by a box formed of metal plates in order to both secure their circuit boards in place and isolate the modules from the instrument from an EMC perspective.

3) *Panel*: The molded front panel features sharp lines to give the product a premium appearance that befits its status as the Hioki Memory HiCorder model with the largest number of inputs. Ease of use and convenience were key considerations, as reflected in such design features as the positioning of the CF card slot and USB receptacle at the top and the use of large, simple rubber switches and a rotary switch that are arranged in the same basic layout as on the MR8847.

4) *Printer*: Hioki took the MR8847's proven printer unit and made improvements to its specifications to accommodate its horizontal installation in the MR8827.

### C. Software

1) *Overview*: The MR8827 was developed as the flagship, all-in-one model of the 8847 series (which consists of the MR8847, MR8741, and MR8740). Since the MR8827 features roughly the same basic hardware architecture and software functionality as the 8847 series, it shares the same source code. Sharing the same operability, functionality, and display ensures that models in the series can be used without confusion. The MR8827 also uses the same data format as the rest of the instruments in the series, allowing it to load waveform and settings files saved by the 8847 (and vice versa).

2) *Display sheet support*: While the built-in display can simultaneously display 32 analog channels and 32 logic channels, analysis can prove difficult due to the large number of waveforms. Hioki equipped the MR8827 with a display sheet function so that users can easily check waveforms while simultaneously measuring all channels.



Memory HiCorder MR8827

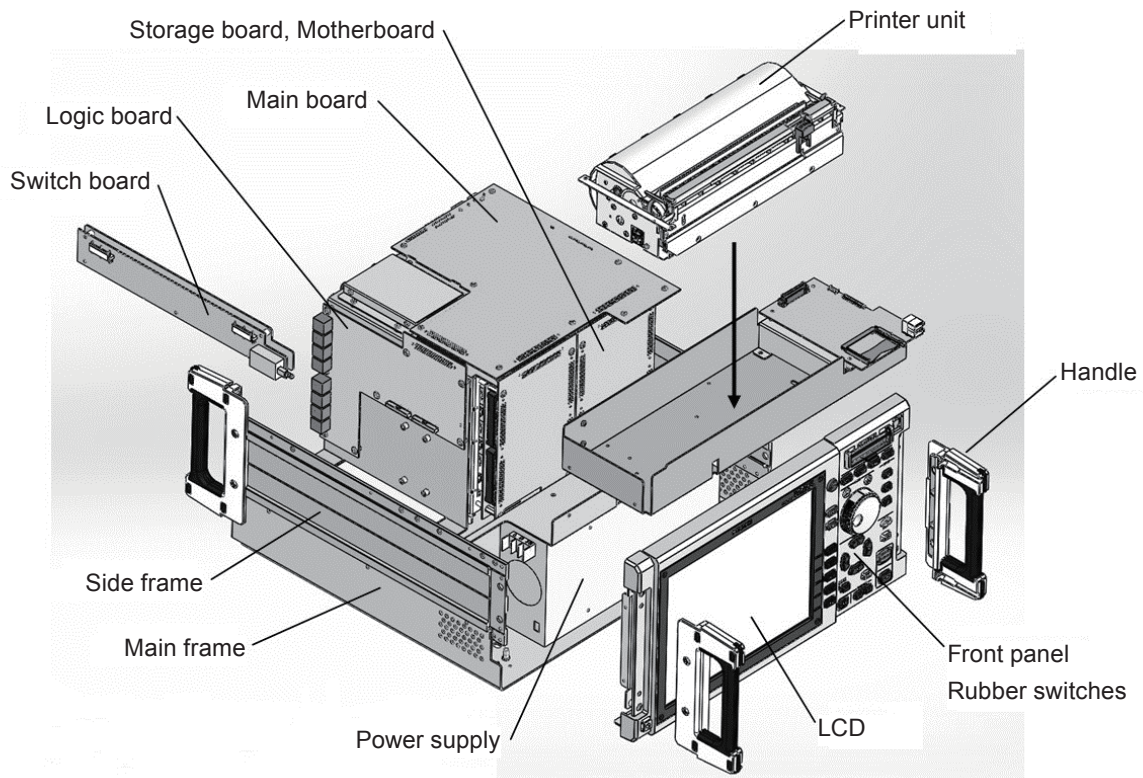

Fig. 2. Exploded view of MR8827 (front).

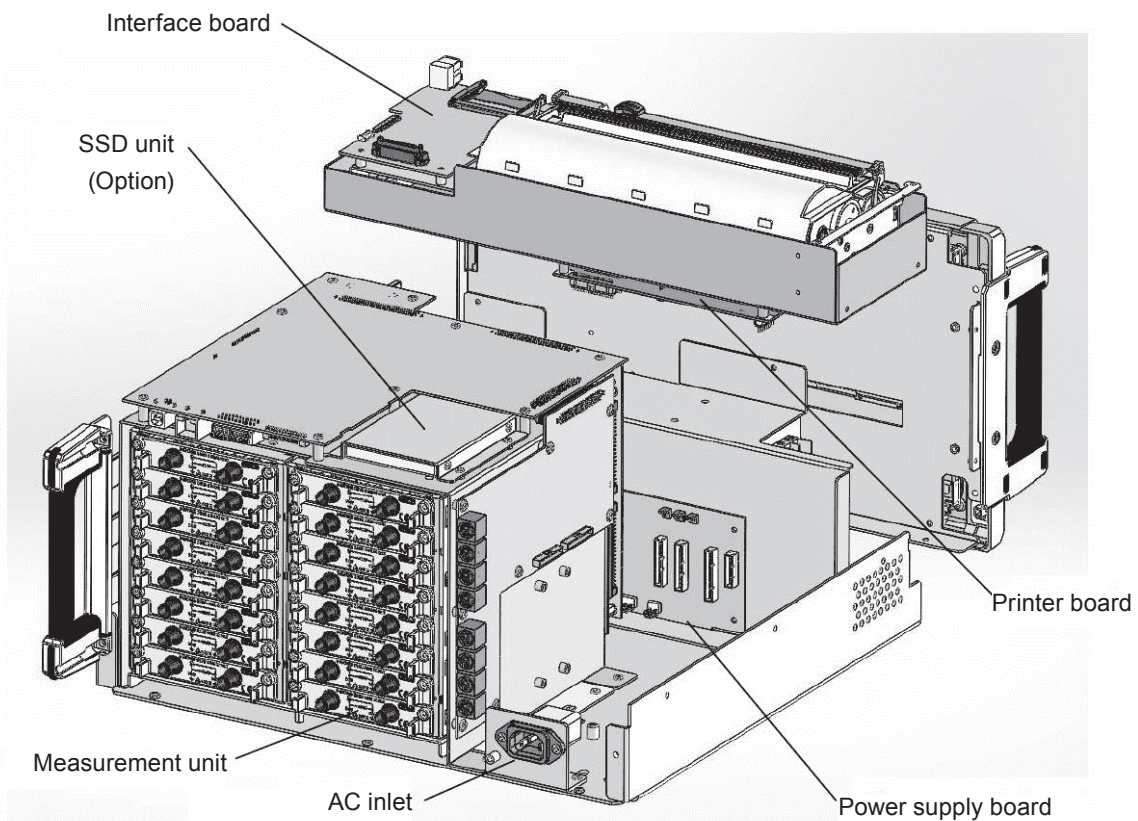

Fig. 3. Exploded view of MR8827 (rear).

TABLE II. COMPARISON CHART

Item		MR8740	MR8741	MR8847	MR8827
Analog channels	Number of channels	2 to 54 ch. <sup>a</sup> (2-block architecture: 32 + 22 ch.)	2 to 16 ch.	2 to 16 ch.	2 to 32 ch.
	Number of modules	Max. 27 modules (16 + 11 modules)	Max. 8 modules	Max. 8 modules	Max. 16 modules
Logic channels	Number of channels	Standard: 8 ch. × 2 Max. 56 ch. × 2	Standard: 16 ch. Max. 64 ch.	Standard: 16 ch. Max. 64 ch.	Standard: 32 ch. Max. 64 ch.
	Number of modules	(Standard + logic modules × 3 × 2) modules	(Standard + logic modules × 3) modules	(Standard + logic modules × 3) modules	(Standard + logic modules × 2) modules
Memory		16 MW/ch.  Memory per channel cannot be increased by reducing the number of channels in use.		-01: 4 MW/ch. -02: 16 MW/ch. -03: 32 MW/ch.  If using 2 ch.: -01: 32 MW/ch. -02: 128 MW/ch. -03: 256 MW/ch.	16 MW/ch.  If using 4 ch.: 128 MW/ch.
Display		External monitor DVI terminal × 2	External monitor DVI terminal	10.4" TFT color screen	
Printer		No		Yes	Yes (optional)
Modules	DVM module	Compatible	Compatible	Not compatible	Compatible
	Current module	Compatible	Not compatible	Compatible	Compatible
	Other	All compatible			
External storage	USB flash drive	Yes			
	CF card	No		Yes	
	Internal drive	No		HDD (optional)	SSD (optional)
Interfaces	LAN	Ethernet 100BASE-TX (FTP server, HTTP server, command-based control)			
	USB communication	No		Command-based control, mass storage	
	Other	Mouse, keyboard (romanized input with <i>kanal/kanji</i> conversion)			
Functionality	Memory	Yes			
	Recorder	Yes			
	X-Y recorder	No		Yes	
	FFT	Yes			
Calculation functionality	Numerical	Yes			
	Waveform	Yes (can be used with memory partitioning) Max. 200000 data points		Yes (cannot be used with memory partitioning) Max. 1000000 data points	
Memory partition function		Yes (can be used with waveform calculation)		Yes (cannot be used with waveform calculation)	
Waveform detection function		No	Yes	Yes	Yes

<sup>a</sup> ch.: channel(s)

The MR8827 provides a total of four sheets for use in managing groups of display-related settings, including on/off state, waveform color, display scale, and position. The sheet in use can be changed on the Waveform screen or Channel Settings screen, providing dynamic control over the display of waveforms.

One example of how this functionality can be used is to check analog and logic waveforms separately by assigning analog waveforms to Sheet 1 and logic waveforms to Sheet 2. Alternatively, it can be used to check detailed changes in one or more select waveforms while monitoring the overall trends exhibited by measured waveforms by assigning all waveforms to Sheet 1 and one or more select channels to Sheet 2.

In this way, the display sheet function allows the MR8827 to deliver the seemingly contradictory capabilities of multichannel measurement and simple analysis.

## V. CONCLUSION

Verifying overall equipment operation and assessing abrupt phenomena in increasingly diverse and complex systems require the ability to measure a larger number of signals on the same time axis. For example, being able to simultaneously measure voltage and current on the primary and secondary sides of an inverter along with logic control signals, switching device temperature, and motor RPM and vibrations as illustrated in Fig. 4 makes it possible to tune the operation of the inverter system in a comprehensive manner. In the event of a problem, it is an easy matter to identify its

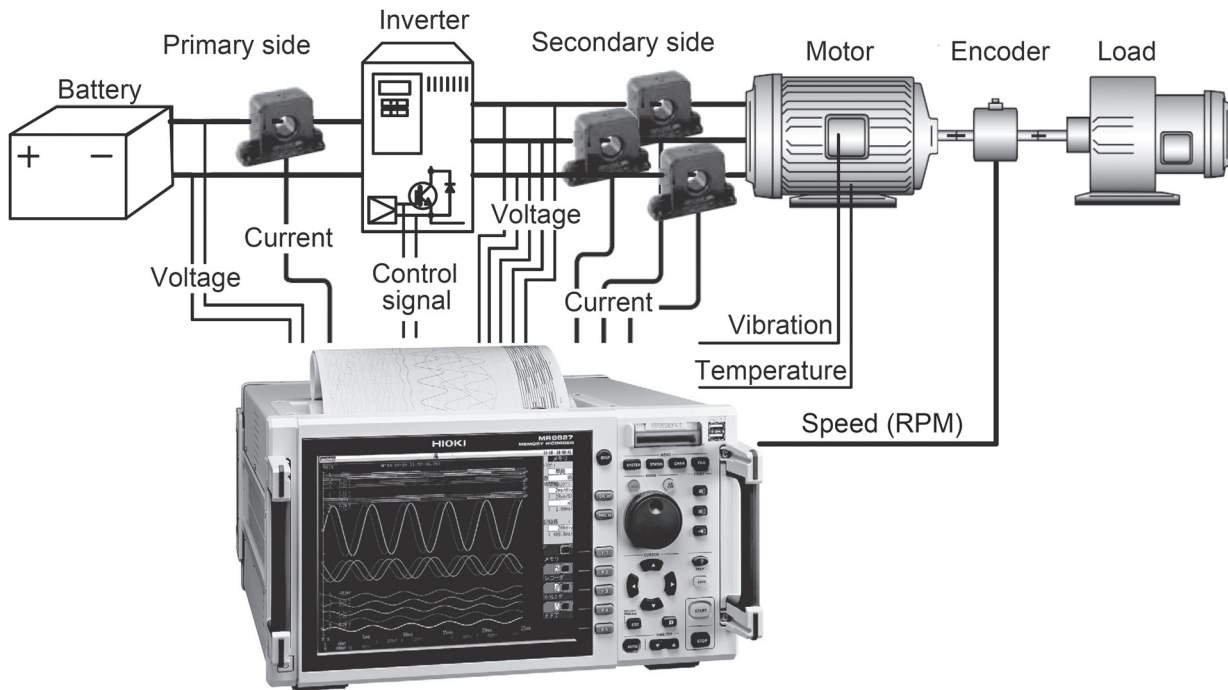

Fig. 4. Example measurement of an inverter system.

cause since all system signals are being measured at the same time. Hioki expects the MR8827 to be valued in monitoring systems requiring measurement of large numbers of signals as well as testing and troubleshooting on production lines.

Koichi Yamamoto\*1, Yoshiki Hattori\*1, Toshiyuki Kondo\*2

#### REFERENCES

- [1] H. Tsukada, "Memory HiCorder 8847," *Hioki Giho*, vol. 30, no. 1, pp. 1-10, 2009. (Japanese).
- [2] H. Tsukada, "Memory HiCorder MR8740/MR8741," *Hioki Giho*, vol. 34, no. 1, pp. 5-10, 2013. (Japanese).

#### REGISTERED TRADEMARK

- CompactFlash is a registered trademark of SanDisk Corporation (USA).

---

\*1 Engineering Division 1, Engineering Department  
 \*2 Engineering Division 10, Engineering Department