

Memory HiLogger LR8450/LR8450-01

Voltage/Temp Unit U8550

Universal Unit U8551

Voltage/Temp Unit U8552

High Speed Voltage Unit U8553

Strain Unit U8554

Wireless Voltage/Temp Unit LR8530

Wireless Universal Unit LR8531

Wireless Voltage/Temp Unit LR8532

Wireless High Speed Voltage Unit LR8533

Wireless Strain Unit LR8534

Wireless LAN Adapter Z3230

Takayuki Kurashima

Field Design Division, Customer Marketing Department

Abstract—The Memory HiLogger LR8450/LR8450-01 is a portable data logger that can simultaneously record multiple channels, including temperature, strain, and voltage signals. The measurement modules are available in plug-in type and wireless type, and wireless modules can be connected wirelessly to the wireless LAN model (LR8450-01). This paper provides an overview of the product, discusses its functions and features, and describes an example measurement application.

I. INTRODUCTION

Multichannel voltage and temperature loggers are widely used for temperature measurement in the environmental and energy fields and for measuring various parameters in the development of automobiles and other transportation equipment. The previous model (Memory HiLogger LR8400), which provides multichannel voltage and temperature measurement capability in a portable footprint, has enjoyed wide use in a broad array of voltage and temperature measurement applications.

Inheriting the portability of the LR8400, the LR8450/LR8450-01 can be combined with other modules according to the application and can measure strain in addition to voltage and temperature. The minimum sampling interval has been reduced from 10 ms to 1 ms, which makes the LR8450/LR8450-01 suitable for recording dynamic strain data as well as sensor outputs of 10 Hz to tens of Hz such as pressure and vibration.



Fig. 1. External appearance of the LR8450/LR8450-01.

In applications that until now have required strain and temperature to be measured using separate instruments before the time axes of the respective measurement results could be aligned and their waveforms reviewed, the LR8450/LR8450-01 provides a single-instrument solution for observing waveforms in real time.

The wireless LAN model (LR8450-01) can be used in combination with a wireless measurement module, achieving a sampling interval of 1 ms, including when connected wirelessly. As a result, the man-hours for installation and wiring work during strain measurement can be significantly reduced.

Fig. 1 depicts the appearance of the LR8450/LR8450-01.

II. OVERVIEW

The LR8450/LR8450-01 features a 7-inch TFT color LCD display. This landscape display is able to display comments and calculation results along with waveforms and measured values.

The wireless connection of the LR8450-01 to the measurement module offers the following advantages:

- Shorter input wires and reduced wiring costs
- Reduced noise effects due to wiring
- Reduction of man-hours required for test preparation
- Since the measurement module can be placed inside the device under test without external wiring, airtightness inside the instrument can be ensured
- Up to seven measurement modules can be wirelessly connected at a time, allowing data from distributed measurement locations to be collected at once

A. Simultaneous Multichannel Sampling at 1 ms Intervals

When using the High Speed Voltage Unit U8553, the LR8450/LR8450-01 can measure voltage with a sampling interval of 1 ms.

When four U8553 modules are installed, 20 channels of voltage data can be measured with a sampling interval of 1 ms. When wirelessly connected to the Wireless High Speed Voltage Unit LR8533, voltage can also be measured with a sampling interval of 1 ms.

B. Dynamic Strain Measurement Capability

When using the Strain Unit U8554, the LR8450/LR8450-01 can measure strain at a sampling interval of 1 ms. The built-in bridge box allows direct connection of strain gages.

Wireless connection with the Wireless Strain Unit LR8534 also supports a sampling interval of 1 ms.

Since strain gages use thin cables, they are prone to disconnection, and there are many applications that require such cables to be stretched over long distances. Wireless measurement has the great advantage that such wiring can be shortened.

C. Mixing and Adding of Plug-in and Wireless Channels

The LR8450/LR8450-01 allows users to freely combine and add up to four plug-in modules. A module with a minimum sampling interval of 1 ms can be combined with a module with a minimum sampling interval of 10 ms, so that fast-changing voltage signals and slow-changing temperature data can be observed simultaneously.

The LR8450-01 allows users to choose to use only the plug-in modules or the wireless modules depending on the situation at hand.

D. Ability to Measure Up to 120 Channels in a Portable Footprint

The LR8450/LR8450-01, when equipped with four 30-channel U8552 Voltage/Temp Units, becomes a portable-sized 120-channel logger for measuring voltage and temperature.

E. Single-instrument Capability for Measuring Up to 330 Channels

Equipped with four U8552 30-channel plug-in modules and seven LR8532 30-channel wireless modules, a single LR8450-01 can measure 330 channels of voltage and temperature data.

F. Maintenance of Sampling Interval Performance When Adding Modules

In previous models, the maximum sampling speed was reduced as the number of input switching relays increased with the addition of modules. In the LR8450, each module has a built-in A/D converter, so that the same maximum sampling speed can be maintained even when additional modules are added.

For example, an LR8450 equipped with four U8550 Voltage/Temp Units, each of which has 15 channels and a minimum sampling interval of 10 ms, can simultaneously measure 60 channels at a sampling interval of 10 ms.

G. Improved Noise Resistance

In environments characterized by exposure to high-frequency noise, accurate temperature measurement may not be possible because the noise may cause the measured value to shift or fluctuate significantly. The LR8450 has been redesigned to dramatically reduce the effects of high-frequency noise. Additionally, the cutoff frequency of the digital filter linked to the data refresh interval can be set individually for each module. By setting a longer data refresh interval for the module measuring temperature and a shorter data refresh interval for the module measuring voltage, the effect of power supply noise during temperature measurement can be reduced even while using a high sampling rate.

H. Easy Registration of Wireless Modules

When using wireless modules, it's necessary to register each module with the LR8450-01 as a wirelessly-connected device.

With the Quick Set function, even first-time users can complete the registration by simply following the on-screen instructions

Users can select the wireless LAN's frequency band channel (1 through 11), and they can check the network congestion status when registering a module. Interference with other wireless LAN devices can be prevented by selecting a channel that is not congested.

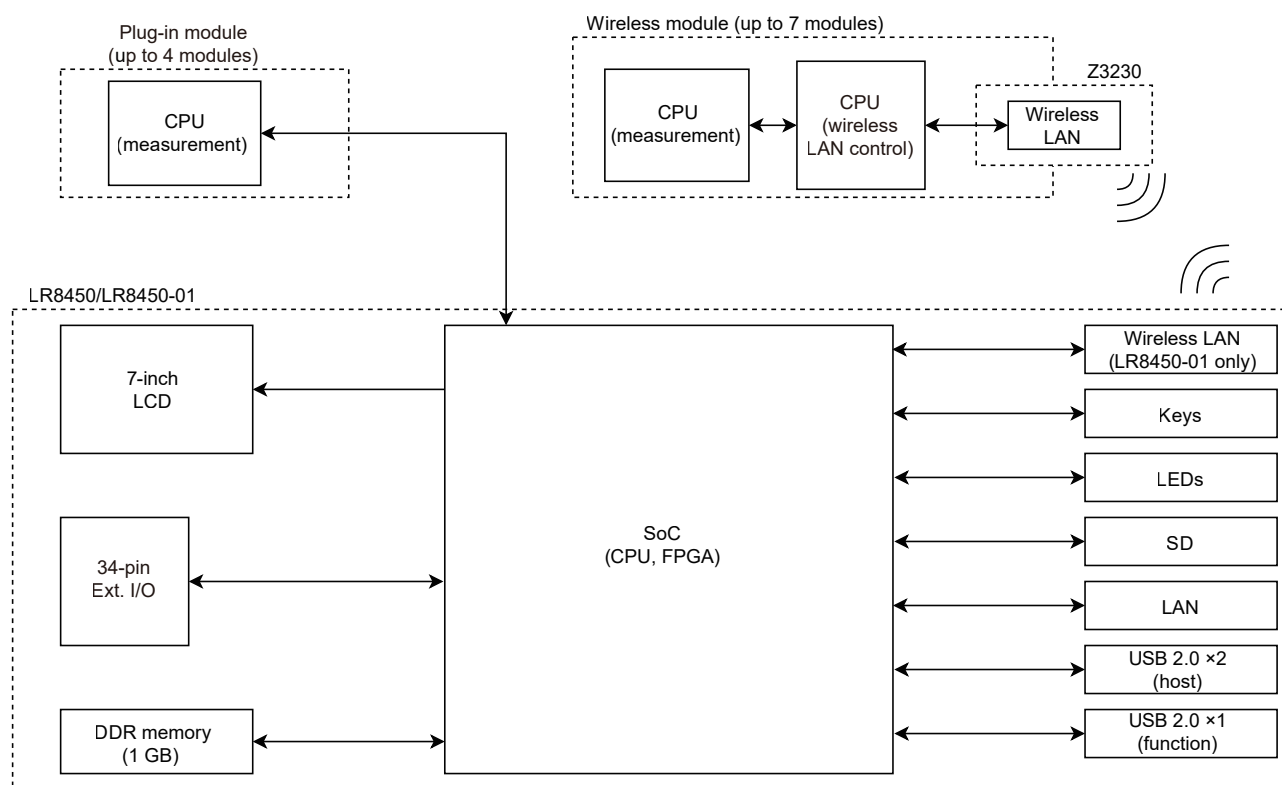

Fig. 2. Overall block diagram.

III. FUNCTIONS AND FEATURES

A. Memory HiLogger LR8450/LR8450-01

Fig. 2 shows the overall block diagram of the LR8450/LR8450-01. The system-on-a-chip (SoC) in the center controls all the main functions, including measurement, communications, and screen display. Up to four plug-in modules can be installed in the upper part of the instrument. The LR8450-01 includes a built-in wireless LAN control unit, allowing wireless modules to be connected via the Wireless LAN Adapter Z3230.

The data measured by each module are processed by the module's internal measurement CPU and integrated into the SoC. The approach of consolidating and distributing the various processes delivers high performance.

1) *Storage control unit and memory control unit:* Although the SoC and DDR memory in the LR8450/LR8450-01 are connected by a single physical bus, the memory is shared by the SoC's dual-core CPU and FPGA. In the previous model, the CPU and FPGA were installed separately, which posed an interoperability challenge. With the SoC, the CPU, FPGA, and memory can be processed seamlessly, enabling high-speed, multi-channel measurements.

2) *External control terminals:* With the advancement of measurement technology, the number of types of sensors for measurement is increasing. In order to supply power to a variety of sensors, this unit has two voltage output terminals whose output voltage can be set individually. One of them is capable of DC output of up to 24 V.

With the increase in the number of measurement channels, the number of alarm outputs has been increased from four in the previous model to eight in the new model. As a result, a total of 34 external control terminal pins are now available for the LR8450/LR8450-01 to meet a wide range of user needs.

3) *Wireless LAN control unit:* Although the previous model supported wireless measurement using the Wireless Logging Station LR8410, the sampling interval was 100 ms at the fastest; the LR8450-01 required high-speed wireless communication capability to enable sampling at 1 ms intervals, 100 times faster than the previous model. To accommodate this requirement, the instrument uses an IEEE 802.11 (b/g/n)-compliant wireless LAN module to handle communications with wireless modules.

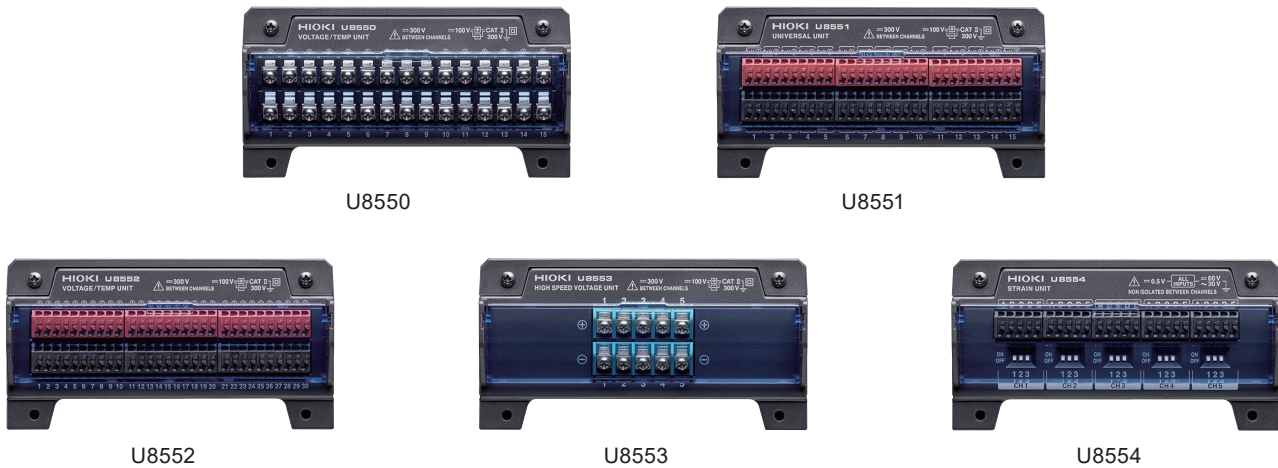

Fig. 3. External appearance of plug-in modules.

B. Plug-in Modules and Wireless Modules

There are five types of measurement modules available. Each of them has a plug-in type and a wireless type.

Figs. 3 and 4 show the external appearance of the plug-in and wireless modules, respectively.

1) *Voltage/Temp Unit U8550, Wireless Voltage/Temp Unit LR8530*: The U8550/LR8530 is equipped with a 15-channel M3 screw terminal block and is capable of measuring voltage and temperature. Compared to the previous model (LR8400), the U8550/LR8530 offers improved measurement accuracy, with voltage measurement accuracy of $\pm 0.05\%$ f.s. except for some ranges. Since each module has a built-in measurement circuit, all modules can perform measurements with a minimum data refresh interval of 10 ms.

Additionally, a major redesign of the filter circuit has boosted resistance to high-frequency common-mode noise of 10 kHz or higher, significantly reducing the effects of common-mode noise on measured values.

2) *Universal Unit U8551, Wireless Universal Unit LR8531*: Equipped with a 15-channel push-button terminal block, the U8551/LR8531 provides roughly the same basic performance as the U8550/LR8530 in terms of characteristics such as accuracy specifications and noise resistance. The module can measure voltage, temperature (thermocouple and resistance temperature detector), resistance, and humidity. The new support for Pt1000 resistance temperature detector expands the range of temperature measurement options. Furthermore, the LR8531 has a voltage output terminal that can be used to supply power to the Humidity Sensor Z2000.

3) *Voltage/Temp Unit U8552, Wireless Voltage/Temp Unit LR8532*: Equipped with a push-button terminal block, the U8552/LR8532 is the first module to be able to measure 30 channels when attached to Hioki loggers. By offering 30 channels with performance on a par with the U8550/LR8530, the U8552/LR8532 allows users to measure more channels with a single module. Although the minimum data

refresh interval is 20 ms for measurements of 16 channels or more, the module achieves a data refresh interval of 10 ms—the same as the U8550/LR8530—for measurements of 15 channels or less.

4) *High Speed Voltage Unit U8553, Wireless High Speed Voltage Unit LR8533*: The U8553/LR8533 is a scanning-type module that can measure up to five channels of voltage data at a minimum sampling interval of 1 ms. As a result, it can measure the voltage waveforms of high-speed, multi-channel sensor outputs and control signals that could not be captured by the 10ms sampling of previous models.

The module uses semiconductor relays to switch input channels faster than previous models. This improvement reduces the switching time between channels while assuring inter-channel insulation performance. Additionally, the use of a $\Delta\Sigma$ -type A/D converter that's capable of high-speed single-cycle settling delivers both noise resistance and shortened integration time. The module achieves a 1 ms sampling interval while maintaining the advantages of the scan method, namely multi-channel measurement and reduced hardware cost.

5) *Strain Unit U8554, Wireless Strain Unit LR8534*: The U8554/LR8534 can measure up to five channels of strain and voltage data at a minimum sampling interval of 1 ms.

Its circuitry incorporates a built-in bridge resistor (120 Ω), which enables measurement with strain gages without a user-provided external bridge box.

With a maximum measurement range of 200,000 $\mu\epsilon$ f.s., the module can measure large strain values.

The auto-balancing function has been improved to reduce the balancing time to approximate 1 s. under no-load conditions when the auto-balancing adjustment value is not significantly off. Additionally, the interface has been redesigned to improve convenience by allowing users to specify multiple channels and easily check the auto-balance results.



Fig. 4. External appearance of wireless modules.

C. Wireless LAN Adapter Z3230

Wireless modules communicate wirelessly with the LR8450-01 via the included Wireless LAN Adapter Z3230, which greatly reduces the number of components on the Z3230 board and provides excellent wireless connectivity. Additionally, Hioki has created an environment that simulates line-of-sight communications at a distance of 30 m, which is the specified distance between the wireless module and the device in the product specifications, where Z3230 units are manufactured. The capability is used to verify the signal strength of each manufactured Z3230. In this way, Hioki is able to supply products with stable and consistent signal strength.

D. LR8450/LR8450-01 Software

1) *Platform:* The basic functionality of the LR8450/LR8450-01 is the same as the previous model, but the platform used in that device has been revamped. Hioki built a new platform that uses a multicore SoC with one FPGA and two CPU cores. One of the CPU cores uses a real-time operating system because it's responsible for processing that requires real time performance. The other CPU core uses a general-purpose operating system that can utilize existing software assets while providing support for the instrument's various hardware assets. These two different operating systems utilize inter-core communications to function in a coordinated manner.

2) *Roles of the general-purpose operating system:* The general-purpose operating system plays the following roles:

- *Performing user interface, communications, and file processing:* The user interface unit and communication unit utilize existing software assets. This approach allowed Hioki to significantly reduce development man-hours.

- *Controlling wireless modules:* The operating system buffers the measurement data sent asynchronously from the wireless modules, reorders the data by sample number, and controls all seven wireless modules by performing the following processes:

- Transferring measurement data to the real-time operating system
- Resending measurement data when wireless connection is interrupted
- Synchronizing sampling of plug-in and wireless modules

3) *Roles of the real-time operating system:* The instrument requires real-time processing of measurement data recorded at intervals of 1 ms minimum. The real-time operating system plays the following roles:

- Controlling plug-in modules
- Organizing the data of the wireless module and the plug-in module sent from the general-purpose operating system
- Performing calculations, trigger detection, and alarm detection for measurement data

E. Physical Design

1) *Connections to plug-in modules:* One feature of the LR8450/LR8450-01 is its adoption of a physical design that allows users to attach and detach all plug-in modules themselves.

The screws that secure the plug-in modules to the instrument are located on the front of the instrument, not the rear. Plug-in modules are sometimes secured to the instrument while still connected to numerous thin wires of thermocouples. If the mounting screws were located on

Memory HiLogger LR8450/LR8450-01

the rear of the instrument, the instrument will have to be reoriented when tightening the screws, and this movement may break the thermocouple wires. Placing the screws to secure the plug-in module on the front of the instrument reduces amount of the stress placed on thermocouples.

Additionally, the previous model (LR8400) used four screws and two metal parts to secure each expansion module in place. The LR8450/LR8450-01 use a robust mating mechanism to facilitate connections with plug-in modules, allowing each to be secured with just two screws while accommodating up to four modules.

2) *Connecting the Wireless LAN Adapter Z3230:* As illustrated in Fig. 5, a screw is used to connect the Z3230 to wireless modules (LR8530, LR8531, LR8532, LR8533, and LR8534).

Generally speaking, most adapters designed to provide wireless communications between devices are held in place by either friction between connectors themselves or by a latch-type mechanism.

Such designs have the advantage of simplifying repeated connections and disconnections without the need for tools. On the other hand, the stability of communications may be compromised if the adapter comes off due to vibrations over an extended period of time or the mechanical shock of the device being dropped.

Since data loggers are required to keep recording data without interruption, Hioki used screws to attach the Z3230 to the wireless module to prevent the adapter from falling off to improve operational reliability.

F. User Documentation

The LR8450's user documentation consists of a Quick Start Manual (paper-based and PDF) and an Instruction Manual (PDF). Paper-based manuals have the advantage of immediate accessibility, while PDFs offer benefits in terms of visibility and searchability.

Recognizing that user documentation may be used before as well as after purchase, for example during trial use or for the purpose of comparison with other companies' products, Hioki added a section to introduce useful measurement functions. The *Quick Start Manual* won the Manual of the Year Award at the 2020 Japan Manual Awards, sponsored by the Japan Technical Communicators Association (a general incorporated foundation).

IV. EXAMPLE MEASUREMENT APPLICATION

A. Measurement of Inverter Temperature

Fig. 6 shows a setup for measuring the temperature of the terminals of the motor drive inverter as an example of measurements that demonstrate the improved noise resistance of the LR8450.

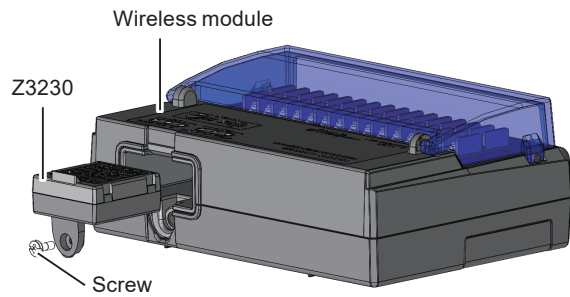

Fig. 5. Z3230 mounting mechanism.

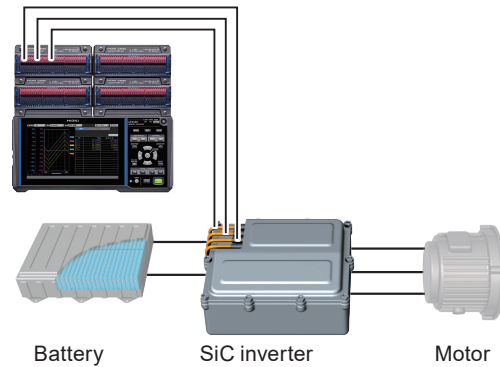

Fig. 6. Measurement of the temperature of an inverter terminal.

Fig. 7 shows the waveform measured by connecting the LR8450 to the Voltage/Temp Unit U8550. Fig. 8 shows the a waveform measured by the previous model (LR8400) for comparison. The instruments were used to measure an inverter's PWM output terminal (W-phase). Hioki compared the effects of high-frequency noise from the inverter on the temperature measurement waveforms.

The measurement conditions were as follows:

- Inverter settings
Carrier frequency: 200 kHz
Motor speed: 500 rpm
- Measuring instrument settings
Range: Thermocouple K, 100°C f.s.
Reference junction compensation: INT (internal compensation by module)
Burnout detection: Off
Power supply frequency filter: 60 Hz
Data refresh interval: 1 s

The results indicate that the previous model (LR8400) exhibits variability in the measured values caused by high-frequency noise starting immediately after the inverter starts operating and lasting until it stops. By contrast, the U8550 exhibits a clear improvement in noise resistance, with almost no effect on the measured values, even when the inverter starts operating.

Thus, changes made to the filter settings in the circuit design for LR8450 modules yield significant improvements

in resistance to high-frequency noise. Robust noise resistance is important for measuring temperature in noisy environments, for example when measuring the temperature of an inverter.

V. CONCLUSION

The LR8450/LR8450-01 combines the long-selling LR8400 series, which uses plug-in modules, with the LR8410 series, which provides wireless multi-channel measurement capability.

Despite its portable size, the logger can measure not only voltage and temperature, but also dynamic strain by sampling at intervals as short as 1 ms, 10 times shorter than the previous model.

Wireless connectivity significantly reduces installation man-hours and wiring troubles for strain gage use.

Hioki encourages potential users to experience the advantage of being able to capture large numbers of channels of temperature, strain, and other data simultaneously and wirelessly.

Yuma Ikeda¹, Shuhei Takeda¹, Yoshitaro Nishimura², Hiroaki Yamazaki², Eiji Ohnishi³, Shinji Nishimura³, Takuya Takeuchi⁴, Makoto Muto⁴, Hiroshi Kubota⁵

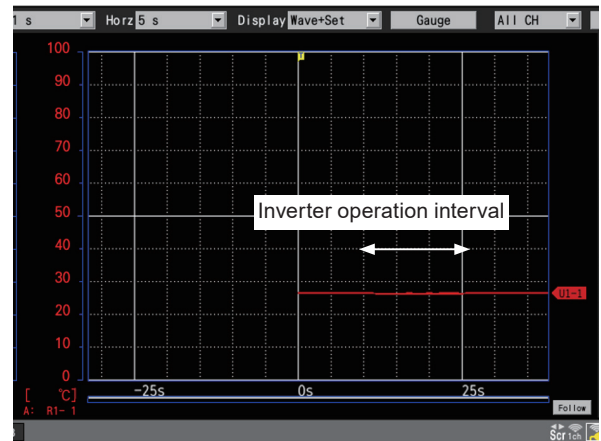

Fig. 7. Temperature measurement using the LR8450.

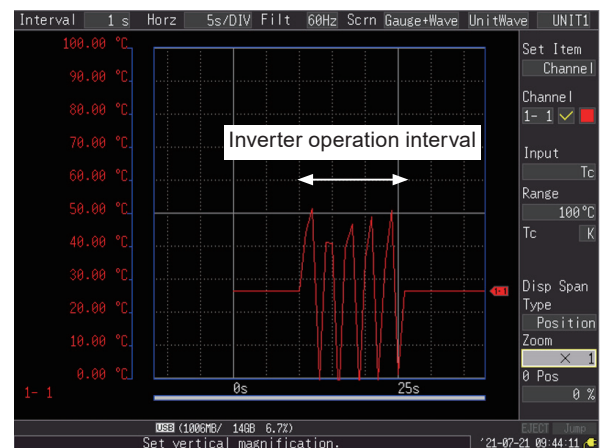

Fig. 8. Temperature measurement using the LR8400.

¹ Analog Block, AE Unit

² Digital Block, AE Unit

³ Software Block, AE Unit

⁴ Mechanism Block, AE Unit

⁵ Design Operation Division, Business Promotion Center