

INBLOX® Ethernet head module

Function

The **Ethernet head module** is the basis of the premium and comfort version of the INBLOX® series. In addition to its 24 V supply voltage connection it has got a LAN connection for the integrated web server. The head is the core of the smart INBLOX® series and can be extended to max. 20 segments and five segments resp. by Diag Rep modules and Diag+ Rep modules. An alarm module can be connected in place of a fifth extension module. Event alarms are then given by switching contacts.

The E-head is provided with an extended logic and alarms are shown on the web screen as known from the INSpektor®. For every extension module a device matrix with certain colours for relevant events can be displayed and the alarms stored as snapshots (up to 100 per extension module).

The head has different options to alert the user in case of network deterioration. It is possible to send an email, an SNMP trap or the INBLOX® can be integrated in a network monitoring software, such as PROmanage® NT.

Technical data

- Voltage supply: 24 VDC
- Power supply: 0,3 A
- Connection: screw terminal for 24 V voltage supply
LAN-Connection for Web interface
- Baud rate: 9,6 kbps to 12 Mbps
- Ethernet:
 - Baud rate: 100 Mbps / 10 Mbps
 - Connection: RJ45
 - Protocols: IPv4 via DHCP or manual
 - Time server: NTP-time synchronizing

General data

- Installation: 35 mm DIN top-hat rail
- Dimensions (H x W x D): 114,5 x 22,5 x 99 mm
- Protective system: IP20
- Operating temperature: 5 °C to 55 °C
- Storage temperature: -20 °C to 70 °C
- PROFIBUS types: DP, DP-V1, FMS, MPI
- Extension: DP Diag Rep, DP Diag+ Rep, alarm module
PA Diag+, DP-Master
- Automatic alarm: Email
SNMP-Trap
SNMP-request with PROmanage® NT

LED



Power: lights up green, if 24 V is connected



Run: blinks green at 1 Hz, rate if everything is o.k.



INBLOX® Ethernet head module

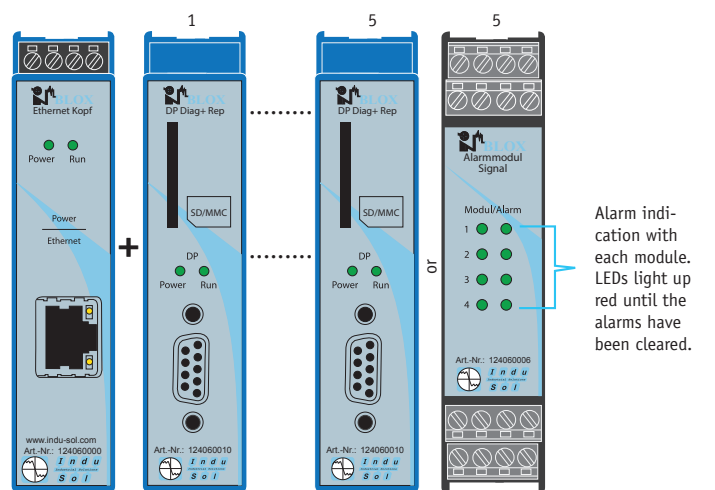

Sample configuration Comfort-Line

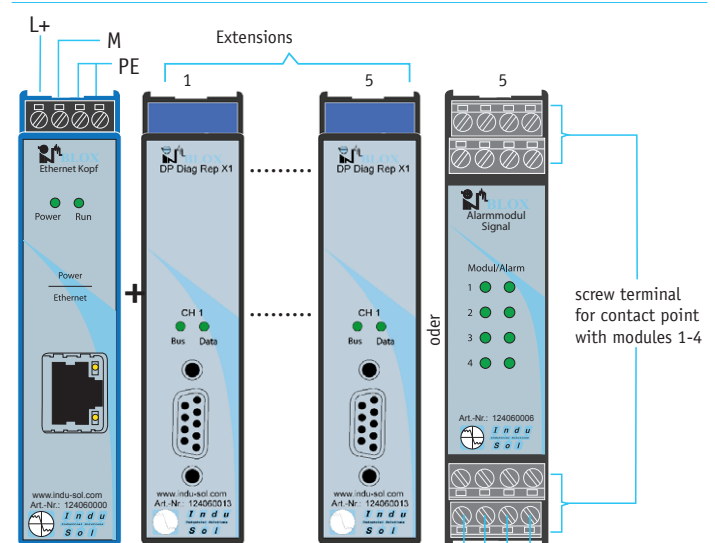

Sample configuration Premium-Line

Ordering details

INBLOX® Ethernet head module (E head)

Art. No.

124060000

INBLOX® Extension module Diag Rep X1

Function

The extension **DP Diag Rep X1 module** is simply connected to the INBLOX® head module and is coupled with the backplane bus directly. The data exchange and power supply for this module takes place via the backplane bus. Each of these extension modules has an integrated PROFIBUS analysis, which monitors and assesses the whole telegram communication logical and physical. The determined state of network quality can be always requested via the web interface of the INBLOX® Ethernet head module or directly via the status LEDs.

The extension DP Diag Rep X1 provides a PROFIBUS interface for connection of a PROFIBUS connector via SUB-D socket. The PROFIBUS network can be expanded by another segment or analysed by a further PROFIBUS master system per extension module, according to configuration of the INBLOX® Ethernet head module.

If a segment ends or begins immediately on a connection of the extension module, the bus termination resistor should be activated directly on the connector. The PG socket of the connector can be used as online measuring point for suitable diagnostic tools.

Technical data

- Voltage supply: 24 VDC with a backplane bus
- Power supply: 0,3 A with a backplane bus
- Connection: 9-pole sub-D PROFIBUS-connection
- Baud rate: 9,6 kbps to 12 Mbps

General data

- Installation: 35 mm DIN top-hat rail
- Dimensions (H x W x D): 114,5 x 22,5 x 99 mm
- Protective system: IP20
- Operating temperature: 5 °C to 55 °C
- Storage temperature: -20 °C to 70 °C
- PROFIBUS-types: DP, DP-V1, FMS, MPI

LED

Bus: Bus health per channel

- **Green:** Everything is okay
- **Red:** Error telegram, telegram repetition, diagnostic messages, node failure

Data: ● **Green:** Bus activity on the channel

- **Red:** Configuration problems in PB
- **Off:** No bus activity



INBLOX® Extension module Diag Rep X1

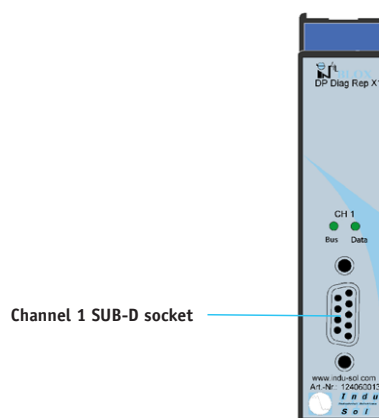

Connection diagram

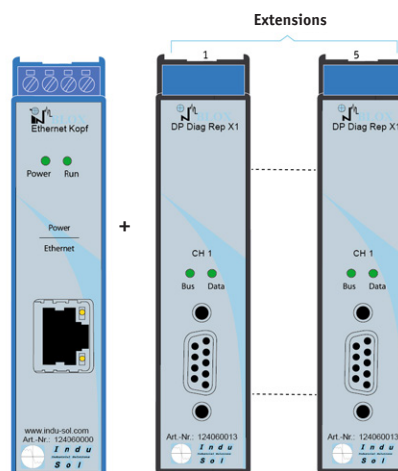

Sample configuration

Ordering details

Art. No.

INBLOX® Extension module DP Diag Rep X1

124060013

INBLOX® Extension module Diag Rep X2

Function

The extension **DP Diag Rep X2 module** is simply connected to the INBLOX® head module and is coupled with the backplane bus directly. The data exchange and power supply for this module takes place via the backplane bus. Each of these extension modules has an integrated PROFIBUS analysis, which monitors and assesses the whole telegram communication logical and physical. The determined state of network quality can be always requested via the web interface of the INBLOX® Ethernet head module or directly via the status LEDs.

The extension DP Diag Rep X2 provides a PROFIBUS interface for connection of a PROFIBUS connector via SUB-D socket. The PROFIBUS network can be expanded by another segment or analysed by a further PROFIBUS master system per extension module, according to configuration of the INBLOX® Ethernet head module.

If a segment ends or begins immediately on a connection of the extension module, the bus termination resistor should be activated directly on the connector. The PG socket of the connector can be used as online measuring point for suitable diagnostic tools.

Technical data

- Voltage supply: 24 VDC with a backplane bus
- Power supply: 0,3 A with a backplane bus
- Connection: 2 x 9-pole sub-D PROFIBUS-connection
- Baud rate: 9,6 kbps to 12 Mbps

General data

- Installation: 35 mm DIN top-hat rail
- Dimensions (H x W x D): 114,5 x 45 x 99 mm
- Protective system: IP20
- Operating temperature: 5 °C to 55 °C
- Storage temperature: -20 °C to 70 °C
- PROFIBUS-types: DP, DP-V1, FMS, MPI

LED

Bus: Bus health per channel

- **Green:** Everything is okay
- **Red:** Error telegram, telegram repetition, diagnostic messages, node failure

Data: ● **Green:** Bus activity on the channel

- **Red:** Configuration problems in PB
- **Off:** No bus activity



INBLOX® Extension module Diag Rep X2

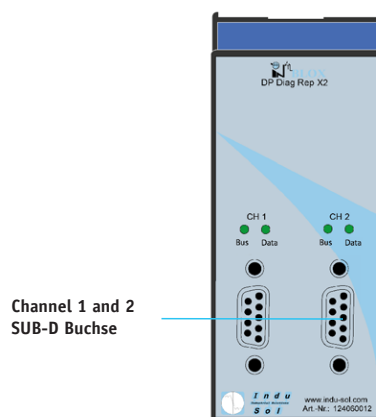

Connection diagram

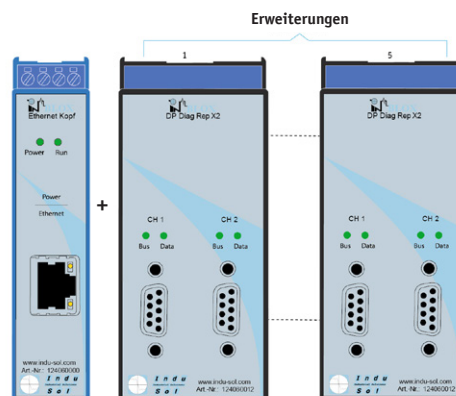

Ordering details

Art. No.

INBLOX® Extension module DP Diag Rep X2

124060012

INBLOX® Extension module DP Diag Rep X4

Function

The extension **DP Diag Rep X4** is provided with four terminals and is able to open four segments in each case. It is simply connected to the head and is coupled with the backplane bus directly. It obviates the need of a separate voltage supply. Up to five extension modules can be connected to every head, whereby it is possible to create up to 25 segments (Basic Repeater) or 20 segments (E head) per network. The PROFIBUS can be converted from its original line topology to a star topology and spur lines designed without reservation. The applied LEDs ensures for a first simple diagnosis and monitoring. The diagnosis is also possible via the webservice, when its connected to the E-head.

Technical data

- Voltage supply: 24 V with a backplane bus
- Power supply: 0,3 A with a backplane bus
- Connection: 4 screw terminals – OUT (assignment: shield/B/A/shield)
- Transmission rate: 9,6 kBit/s to 12 MBit/s

General data

- Installation: 35 mm DIN top-hat rail
- Dimensions (H x W x D): 114,5 x 22,5 x 99 mm
- Protective system: IP20
- Operating temperature: 5 °C to 55 °C
- Storage temperature: -20 °C to 70 °C
- PROFIBUS types: DP, DP-V1, FMS, MPI

Terminal configuration

PROFIBUS DP

Terminal connection for DP

Channel 1	Channel 2
2 B	6 B
3 A	7 A
1+4 shield	5+8 shield

Channel 3	Channel 4
10 A	14 A
11 B	15 B
9+12 shield	13+16 shield

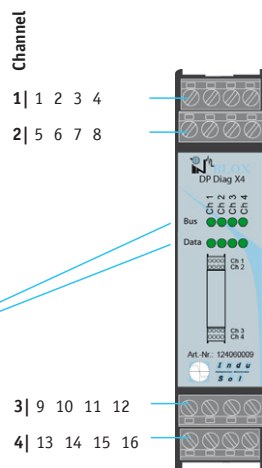

Bus (Bus quality)	DP1	DP2	DP3	DP4
	●	●	●	○
Data (Bus activity)	●	●	●	○

BUS LED GREEN: lights up green, if everything is okay

Data LED GREEN: Data traffic exists

BUS LED RED: detected defects e.g.

- Error telegrams,
- Telegram repetition,
- Diagnostic messages,
- Node failure

Ordering details

INBLOX® Extension DP Diag Rep X4

Art. No.

124060009



INBLOX® Extension module DP Diag Rep X4

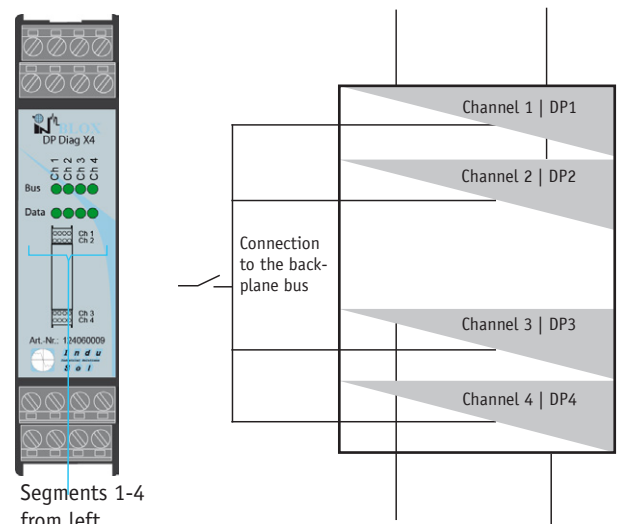

Sample configuration

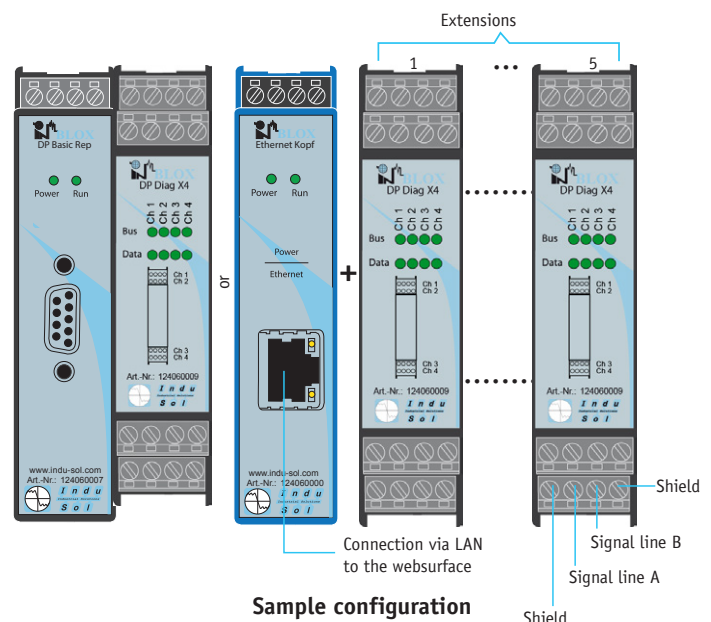

Sample configuration

INBLOX® DP Diag+ Rep

Function

The extension **DP Diag+ Rep module** is simply connected to the INBLOX® head module and is coupled with the backplane bus directly. The data exchange and power supply for this module takes place via the backplane bus. This expansion module has an integrated PROFIBUS analysis, which monitors and assesses the whole telegram communication logical and physical. The determined state of network quality can be always requested via the web interface of the INBLOX® Ethernet head module or directly via the status LEDs.

The extension DP Diag+ Rep provides a PROFIBUS interface for connection of a PROFIBUS connector via SUB-D socket. The PROFIBUS network can be expanded by another segment or analysed by a further PROFIBUS master system per extension module, according to configuration of the INBLOX® Ethernet head module.

Technical data

- Voltage supply: 24 VDC with a backplane bus
- Power supply: 0,3 A with a backplane bus
- Connection: 9-pole sub-D PROFIBUS-connection
- Baud rate: 9,6 kbps to 12 Mbps

General data

- Installation: 35 mm DIN top-hat rail
- Dimensions (H x W x D): 114,5 x 22,5 x 99 mm
- Protective system: IP20
- Operating temperature: 5 °C to 55 °C
- Storage temperature: -20 °C to 70 °C
- PROFIBUS-types: DP, DP-V1, FMS, MPI
- Characteristics: card slot for SD/MMC memory cards

LED



Alarm: signal lights red, when alarm is lying ahead



Run: lights up green, if everything is o.k.



INBLOX® DP Diag+ Rep

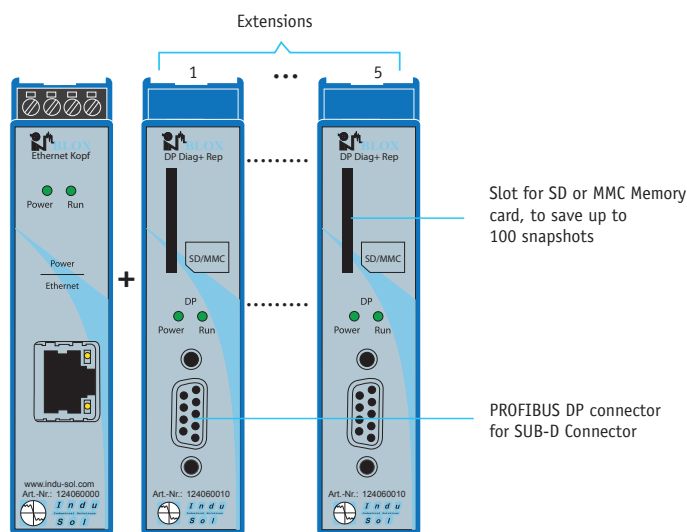

Sample configuration

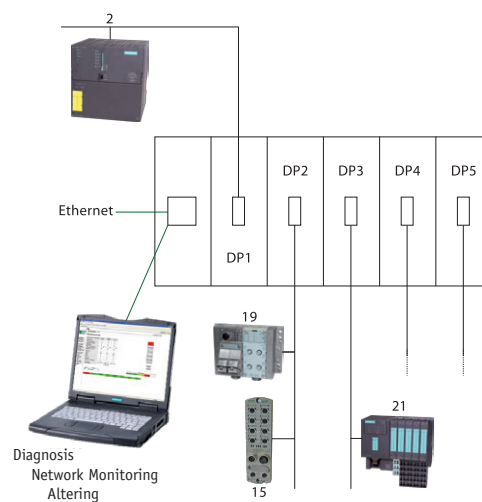

Practical example

Ordering details

INBLOX® DP Diag+ Rep

Art. No.

124060010

INBLOX® Alarm module

Function

The **alarm module** comes with four terminals and is capable of monitoring one INBLOX® module per terminal. If available, it is always the last module to be connected and is coupled directly via a backplane bus. Therefore no separate voltage supply is needed. Every terminal/channel has got a switching output for alarms and a reset input. The alarm module can be installed in connection with the E-head only.

In case of alarm the alarm LED lights up until it is cleared manually via the web interface or the reset input is actuated. The different alarm LEDs show which INBLOX® module is affected. The web interface of the E-head is used to select the relevant module to show the relevant device and detailed information.

Technical data

- Connection: 4 screw terminals
- Voltage supply: 24 V with a backplane bus
- Power supply: 0,3 A with a backplane bus

General data

- Installation: 35 mm DIN top-hat rail
- Dimensions (H x W x D): 114,5 x 22,5 x 99 mm
- Protective system: IP20
- Operating temperature: 5 °C to 55 °C
- Storage temperature: -20 °C to 70 °C

Terminal configuration

Alarm module

Terminal connection

Alarm for module 1	Alarm for module 2
1 IN+	5 IN+
2 IN-	6 IN-
3+4 OUT	7+8 OUT

Alarm for module 3	Alarm for module 4
9 IN+	13 IN+
10 IN-	14 IN-
11+12 OUT	15+16 OUT

LED

Alarm LED
Reset input

- Module 1
- Module 2
- Module 3
- Module 4

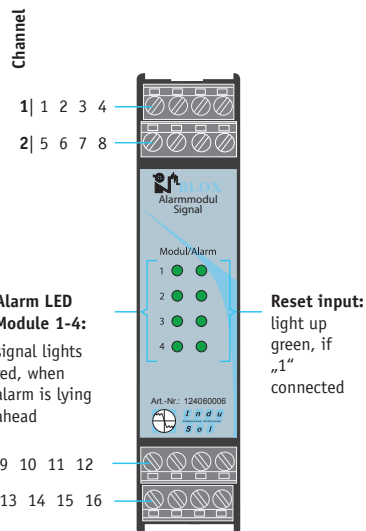

INBLOX® Alarm module

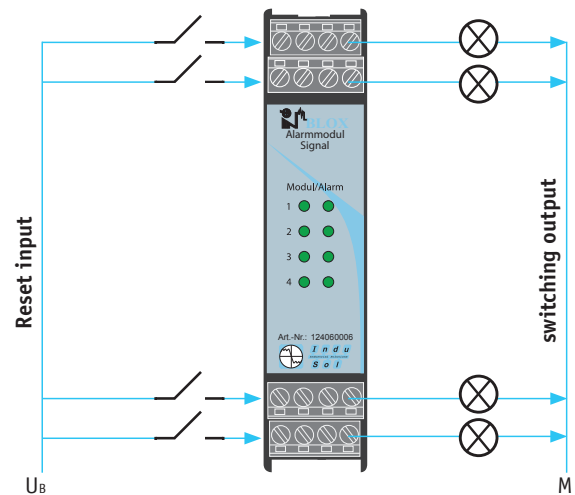

Connection diagram

Extensions 1 to 4, inter-combinable

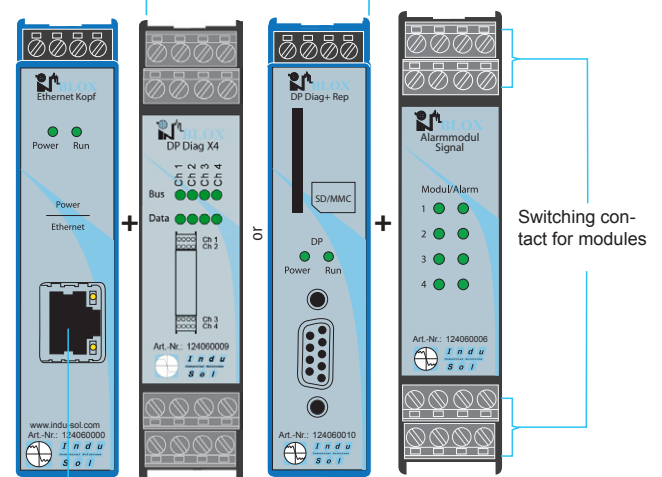

Sample configuration

Ordering details

Art. No.

INBLOX® Alarm module

124060006