



## AIR FRYER DUO 2 *FLEXZONE*

# User guide

Please make sure to read this User Guide prior to using your unit.

# Hello!

## Welcome to Nutricook

Easy cooking, delicious food, better nutrition:  
It's what you get when you're part of our Nutricook community.  
We're so glad you've joined us!  
Now let's get started.

Join us and  
#ElevateYourLife  
@nutricookworld  

Explore more of our products  
and accessories on our website.  
[www.nutricookworld.com](http://www.nutricookworld.com)

**To get help:**  
Our customer service team is always ready  
to answer questions or solve issues.  
Email: [support@nutricookworld.com](mailto:support@nutricookworld.com)

# Contents

---

<b>04</b>	<b>Important safeguards &amp; cautionary information</b>
<b>08</b>	<b>What's included</b>
09	Air fryer parts overview
<b>10</b>	<b>Control panel details</b>
<b>11</b>	<b>Display messages</b>
<b>13</b>	<b>Before you begin</b>
<b>14</b>	<b>Using the basket, cooking trays and divider</b>
<b>15</b>	<b>Adjusting cooking time</b>
<b>15</b>	<b>Adjusting cooking temperature</b>
<b>15</b>	<b>Ending Cooking Cycle in One Zone (when using both Zones)</b>
<b>16</b>	<b>Status indicators</b>
<b>17</b>	<b>Initial test run</b>
<b>18</b>	<b>Cooking</b>
18	Air fry
18	Air fry presets
19	Bake
19	Roast
19	Broil
20	Reheat
20	Dehydrate
20	Single zone cooking
21	Dual Zone Cooking using SYNC FINISH
22	Dual Zone Cooking but ending at different times
23	Ultra Zone Cooking
24	Shaking food
<b>25</b>	<b>Care &amp; maintenance</b>
<b>27</b>	<b>Troubleshooting</b>
<b>28</b>	<b>Warranty</b>

# Important safeguards & cautionary information

**⚠ WARNING!** This appliance generates heat and escaping steam during use. To avoid the risk of serious injury, carefully read all instructions before operating this appliance.



When using any electrical appliance, basic safety precautions should always be observed, including the following [critical information](#).

## GENERAL SAFETY

- **DO NOT** touch hot surfaces. Use handles or knobs. Use oven mitts or potholders.
- **⚠ CAUTION!** Extreme caution must be used when moving unit containing hot oil or other hot liquids.
- To protect against electrical shock, **DO NOT** immerse cord, plugs, or the unit in water or other liquid.
- Close supervision is necessary when any unit is used by or near children.
- This appliance is **NOT** a toy, and children should **NOT** play with it.
- Children should be supervised to ensure that they **DO NOT** play with the appliance.
- This appliance is **NOT** intended for use by persons (including children) with reduced physical, sensory or mental capabilities, or lack of experience and knowledge, unless they have been given supervision or instruction concerning use of the appliance by a person responsible for their safety.
- Unplug from outlet when not in use, during assembly, during disassembly, and before

cleaning. Allow to cool before putting or taking off parts and before cleaning.

- **DO NOT** use appliance other than its intended use. For household countertop use only. **DO NOT USE** outdoors.
- This appliance is not intended to be operated by means of an external timer or separate remote-control system.
- **DO NOT** tamper with any of the safety mechanisms.
- **DO NOT** place on or near a hot gas, electric burner and or in a heated oven. Heat from an external source will damage the appliance.
- **DO NOT** use the air fryer near flammable materials such as curtains, tablecloths, etc. **ALWAYS** place and use the unit on a flat, stable and heat-resistant surface away from heat sources or liquids.
- **NEVER** put baking or parchment paper into the air fryer without food on top. Air circulation can cause paper to lift and touch heating element.
- **ALWAYS** use heat-safe containers. Be extremely cautious if using containers that aren't metal or glass.

- **NEVER** put the appliance against the wall or other appliances when cooking. There should be at least 5 inches of free space for the back side, left/right sides and the upper side of the appliance.
- **DO NOT** place anything on top of your air fryer. **DO NOT** store anything inside your air fryer other than the included accessories when not in use.
- To turn the unit off, press **POWER**  then remove plug from the wall outlet.
- **⚠ CAUTION!**  **HOT SURFACE:** This appliance generates heat and escaping steam during use. Proper precautions must be taken to prevent the risk of burns, fires or other injury to persons or damage to property.
- **⚠ CAUTION!** This appliance is hot during operation and retains heat for some time after turning OFF. **ALWAYS** wear proper hand protection when handling hot materials and allow metal parts to cool before cleaning. **DO NOT** place anything on top of the appliance while it is operating or while it is hot.
- Avoid making contact with moving parts.
- **DO NOT** place any combustible materials on the cooking chamber such as paper, cardboard, plastic, styrofoam or wood.
- Proper maintenance is recommended after each use. Refer to care and maintenance section of this user guide. Allow unit to cool before cleaning.
- **DO NOT** place oversized foods or metal utensils into the air fryer as they may cause fire and/or personal injury.
- **DO NOT** overfill the air fryer basket with food. Excessive amount of food may touch the heating element and can cause a fire hazard.
- An air fryer works with hot air only. **NEVER** fill the basket with oil or fat. This could result in fire and/or personal injury.
- To avoid risk of fire, property damage and personal injury, **DO NOT** spray cooking oil into the cooking chamber.
- **⚠ WARNING! DO NOT** touch any accessories during or immediately after cooking. Allow unit to cool.
- **⚠ CAUTION!** During air frying, hot air is released from the air outlet opening. Keep your hands and face distance from the air outlet opening. Also, be careful of hot steam and air when you remove the Air Fryer Basket from the appliance.
- **⚠ CAUTION! DO NOT block the air vents.**
- **NEVER** use the air fryer without the basket in place. Air Fryer will not operate unless air fryer basket is fully closed.
- To avoid personal injury, **ALWAYS** use proper hand protection and exercise caution when adding or removing food from the air fryer basket.
- **⚠ CAUTION!** After hot air frying, the cooking tray and the air fryer basket and the cooked foods are hot. Extreme caution must be used when handling the air fryer basket.
- **NEVER** place unprotected hands inside the appliance until it has cooled to room temperature.

- **DO NOT** touch hot surfaces with unprotected hands.
- **⚠ CAUTION! Extreme caution must be observed when disposing hot oil or liquids from the air fryer basket.**
- **⚠ WARNING! DO NOT** turn the air fryer basket over after cooking as the hot cooking tray may fall out and create a safety hazard.
- When cooking naturally high fat foods, **DO NOT** turn the air fryer basket over after cooking as the cooking tray may fall out including the excess fats collected on the basket which can cause a safety hazard. Use a tong to transfer food from the basket.
- **DO NOT** clean with metal scouring pads. Metal fragments can break off the pad and touch electrical parts, creating a risk of electric shock.
- **DO NOT** rinse the appliance under tap.
- If the appliance starts emitting black smoke, immediately turn off and unplug your air fryer. White smoke is normal which can be caused by heating fat or food splashing. Black smoke indicates food is burning or there is a circuit problem. Wait for smoke to stop before opening the air fryer basket. **Contact customer service for any assistance.**
- If this appliance begins to malfunction during use, immediately pull the air fryer basket out of the body. Then remove plug from wall outlet. **DO NOT** use or attempt to repair the malfunctioning appliance.
- **DO NOT** leave this appliance unattended during use.

- Keep the cord out of reach of children and infants to avoid the risk of electric shock and choking.
- **⚠ WARNING!** After air frying, make sure to place the air fryer basket on a stable, level, clean, heat-resistant and dry surface when transferring food from the basket.
- **NEVER** move a hot Air Fryer or an Air Fryer containing hot food. Allow to cool before moving.
- **⚠ WARNING!** This Air Fryer should **NOT** be used to boil water.
- **⚠ WARNING!** This Air Fryer should **NEVER** be used to deep fry foods.
- All users of this appliance must read and understand this instruction manual before operating or cleaning this appliance. Failure to follow any of the important safeguards and instructions for safe use is a misuse of your appliance that can void your warranty and create the risk of serious injury.

## ELECTRICAL SAFETY

**⚠ CAUTION:** To avoid risk of electric shock, **NEVER** immerse the cord, plug, or air fryer base in water or other liquids.

- **DO NOT** use this product in locations with different electrical specifications or plug types. **DO NOT** operate with any type of plug adapter or voltage converter device, as these may cause electrical shorting, fire, electric shock, personal injury or product damage.
- **DO NOT** modify the plug in any way, as doing so will void the warranty.
- **DO NOT** pull, twist or mistreat the power cord.
- The use of attachments or parts not recommended and sold by Nutricook may cause fire, electric shock, personal injury, or product damage and will void the warranty.
- If the supply cord is damaged, it must be replaced by its service agent or similarly qualified persons in order to avoid a hazard.
- **ALWAYS POWER OFF** and **UNPLUG** the appliance when it is not in use or **BEFORE** cleaning.
- **DO NOT** allow the cord to hang over the edge of the table or counter. **DO NOT** pull, twist, or damage the power cord. **DO NOT** allow cord to touch hot surfaces, including the stove.
- **DO NOT** let cord hang over edge of table or counter, or touch hot surfaces. The cord can get tangled or cause the appliance to fall. Bring it to a qualified technician for examination, repair or electrical and mechanical adjustment.
- **DO NOT** operate this appliance with a damaged cord or plug or if the appliance malfunctions, or is dropped or damaged in any manner.
- Use of adapters and converters is considered an unauthorized modification of the product and as such voids the warranty. Use of this product in locations with different electrical specifications may result in damage to the product.
- **DO NOT** use an extension cord. A short power-supply cord is used for this appliance to reduce the risk of children grabbing the cord and prevent it from draping over the counter or tabletop where it could be accidentally pulled off or tripped over.

### PLASTICIZER WARNING

**⚠ CAUTION:** To prevent Plasticizers from migrating from the finish of the countertop or tabletop or other furniture, place **NON-PLASTIC** coasters or place mats between the appliance and the finish of the countertop or tabletop. Failure to do so may cause the finish to darken; permanent blemishes may occur or stains can appear.

**Save these instructions!**

**FOR HOUSEHOLD USE ONLY**

# What's included

- 2400W AIR FRYER BASE
- REMOVABLE DIVIDER
- AIR FRYER BASKET
- 2X COOKING TRAY
- USER GUIDE

## Product Specification:

MODEL	CAPACITY	POWER	VOLTAGE	WEIGHT	DIMENSION
AIR FRYER DUO 2 FLEXZONE AFD285	8.5 L	2400 W	220-240 V 50/60 Hz	8 kg	41.5 x 31.7 x 38.3 cm

# Air fryer parts overview

**\*NOTE:** Images are for visual representations only. Always refer to actual product.

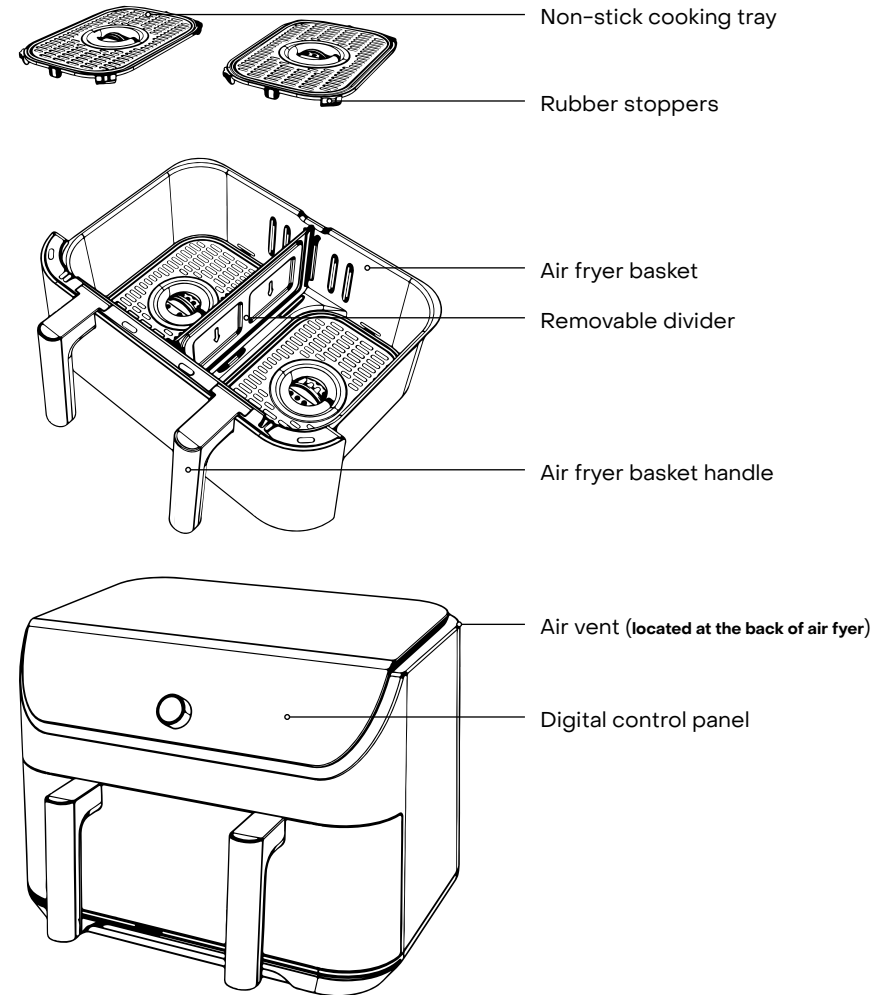

# Control panel details

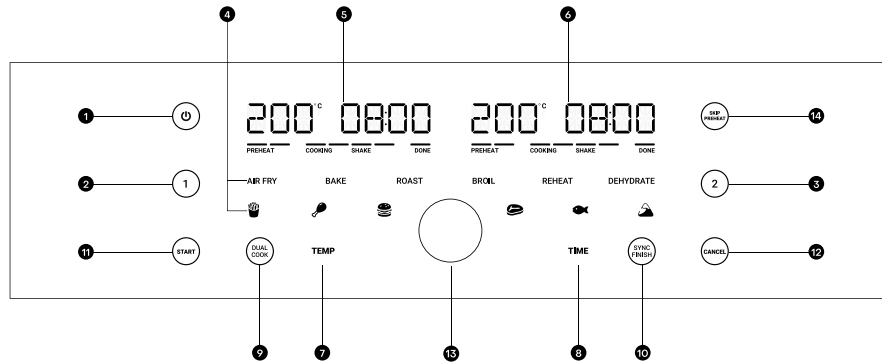

**1 Power button**  
Use to turn unit **ON/OFF**.

**2 Basket 1**  
Press to use left zone.

**3 Basket 2**  
Press to use right zone.

**4 Cooking Programs**  
**6 Main cooking programs**

- AIR FRY
- BAKE
- ROAST
- BROIL
- REHEAT
- DEHYDRATE

**6 Presets**

- FRIES
- CHICKEN
- BURGER
- STEAK
- FISH
- SAMOSA

**5 Basket 1 Temp, Time Display and Cooking Status Indicator**  
Displays temp, time settings, status messages and cooking progress for zone 1.

**6 Basket 2 Temp, Time Display and Cooking Status Indicator**  
Displays temp, time settings, status messages and cooking progress for zone 2.

**7 Temp button**  
Press then use knob to adjust cooking temperature.

**8 Time button**  
Press then use knob to adjust cooking time.

**9 DUAL COOK**  
Press to duplicate settings made in one basket to the other basket.

**10 SYNC FINISH**  
Press to synchronized cooking time in both zones.

**11 START button**  
Use to start a cooking program.

**12 CANCEL button**  
Use to cancel any operation. Pressing this button will return the unit to standby mode.

**13 Control Knob**  
Turn to adjust cooking temp and time.  
Clockwise – increase  
Counter Clockwise – decrease

**14 SKIP PREHEAT button**  
Press to bypass automatic preheating.

# Display messages

HE LLO      Display message when the unit is plugged in.

RE ADY      Display message when the unit is on standby mode.

SE LECT      Display message after selecting a basket/zone. Indicates to select a cooking program.

PRE 0459      Display message when unit is preheating.

ADD FOOD      Display message when preheating is complete.

200° 00:10      Temp and time display.

**Notes on time format:**

During program selection and entering settings, the time format is **HH:MM** (00:10 means 10 minutes)

During preheating and cooking, time counts down in **MM:SS** format.

When using the **DEHYDRATE** program, time counts down in **HH:MM** format if time is set to more than 1 hour and switches to **MM:SS** format if remaining time is less than 1 hour.

**END** Display message when **CANCEL** is pressed while a cooking program is in Preheating or in Cooking status.

**OFF** Display message when unit is powered **OFF**.

**CLOSE BASKET** Display message when basket is opened.

**ENJOY** Display message when cooking time is complete.

**E 1** Display message for error codes. Refer to **Troubleshooting** section of this user guide for a complete guide on the do's and don'ts when an error code appears.

**ON HOLD** Display message when a basket/zone is on hold during cooking using **SYNC FINISH**. Indicates cooking has not yet started on that basket/zone as the time is synced with the other basket/zone.

## Before you begin

1. Remove and safely discard all packaging materials, tapes and any temporary labels from inside and outside of the air fryer. Ensure that there is no packaging underneath and around the air fryer and its accessories.
2. Verify that all parts are accounted for.
3. Place the air fryer on a stable, level, clean, heat-resistant, dry surface and away from external heat sources. Ensure there is a minimum distance of 10cm of space on both sides and 30cm above.

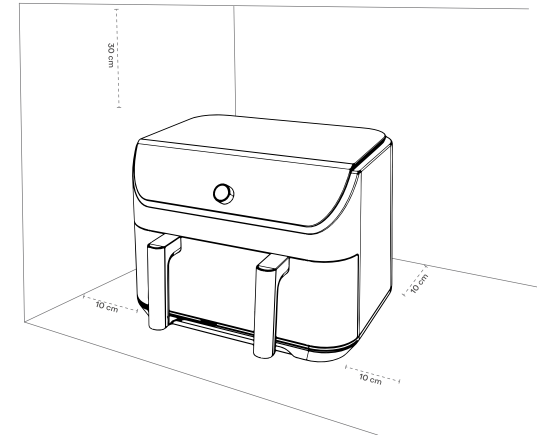

4. Read all Important safeguards and cautionary information in this User guide. Failure to do so may result in property damage and/or personal injury.
5. Follow Care & maintenance instructions in this User guide to clean the air fryer and its accessories before cooking. Ensure that all surfaces and accessories are dry before using the unit.

**⚠ \*WARNING:** Read this User guide carefully and completely, and retain for future reference. Failure to adhere to safety instructions may result in serious injury.

## Using the basket, cooking trays and divider

Before cooking, carefully install the cooking trays in the bottom of the basket.

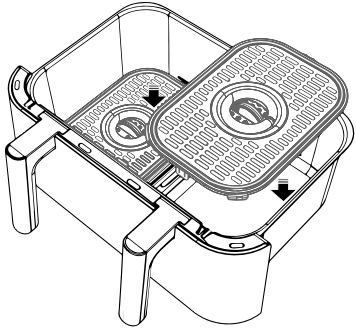

When you're cooking in only one zone or using both zones at the same time for different foods, carefully put the divider in. Slide it into the middle guides of the basket and gently press it down to secure it in place.

**NOTE:** The divider separates the basket into two 4.25L zones which can be controlled independently.

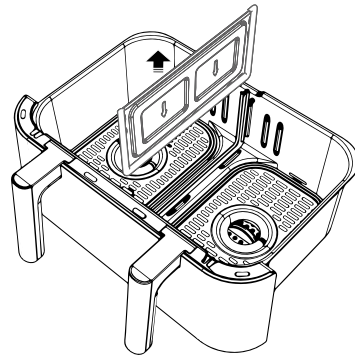
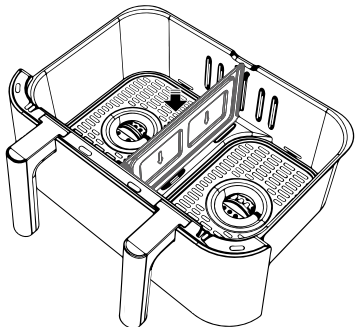

When cooking in Ultra Zone, remove the divider to use the whole 8.5L basket capacity, perfect for larger portions or family-sized meals.

**NOTE: ALWAYS insert the air fryer basket into the main unit. NEVER use the air fryer without the basket in place.**

## Adjusting cooking time

### Before Cooking

Press **TIME** button and turn knob clockwise to increase or counter clockwise to decrease cooking time.

### During Cooking

When cooking in **both zones**, select the zone you want to adjust. Press **TIME** button and turn knob clockwise to increase or counter clockwise to decrease cooking time.

Note:

- Adjusting cooking time in either of the zones while **SYNC FINISH** is active will terminate the **SYNC FINISH** feature and cooking in both zones will end at different times.
- When in **DUAL COOK** mode, cooking time adjustment is duplicated across zones.

## Adjusting cooking temperature

### Before Cooking

Press **TEMP** button and turn knob clockwise to increase or counter clockwise to decrease cooking temperature.

### During Cooking

When cooking in both zones, select the zone you want to adjust. Press **TEMP** button and turn knob

clockwise to increase or counter clockwise to decrease cooking temperature.

Note:

- When in **DUAL COOK** mode, cooking temperature adjustment is duplicated across zones.

## Ending Cooking Cycle in One Zone (when using both Zones)

- Select the zone you would like to cancel.
- Press **CANCEL** button to end cooking cycle in that zone.
- END** will appear on display while cooking on the other zone will continue.

Note:

- Pressing **CANCEL** (without first selecting a zone) will terminate cooking in both zones.



# Status indicators

## PREHEAT

All cooking programs (except **REHEAT** and **DEHYDRATE**) enter the automatic preheating cycle as soon as **START** is pressed. Preheating is optional but recommended for better results.

1. Place the cooking tray in the basket and insert air fryer basket into the unit.  
**Note:**
  - If using programs without automatic preheating, you can add food in the basket before inserting into the unit.
  - If using programs with automatic preheating and you want the unit to preheat first before cooking, **DO NOT** add the food in the basket yet.
2. Press **1** (for the left zone) or **2** (for the right zone).
3. Display shows **SELECT** and all cooking programs are illuminated.
4. Select any of the cooking programs.
5. Optionally, adjust time and temperature.
6. Press **START** to begin.
7. Unit starts to preheat. Display shows **PRE** and countdown time. **PREHEAT** illuminates and status bar blinks. **SKIP PREHEAT** also illuminates.  
**Note:**  
Optionally, press **SKIP PREHEAT** button to bypass Preheating. Once press, unit proceeds to cooking cycle.

## COOKING

1. After Preheating, display shows **ADD FOOD**.
2. Open the basket and add your ingredients.

3. Close basket to begin cooking. **COOKING** indicator illuminates and status bar blinks. Cooking time counts down.

## SHAKE/FLIP FOOD

1. Halfway through the cooking time, **SHAKE** reminder is activated and blinks on the screen.

**Note:**

**SHAKE** is not activated for cooking programs **BAKE**, **ROAST**, **BROIL**, **REHEAT** and **DEHYDRATE**

2. Open the basket and shake or flip food using a silicone-tipped tong.
3. Insert the basket back to the unit to continue cooking.

## DONE

1. When cooking time is up, display shows **ENJOY**. The **DONE** indicator and its status bar illuminates.

# Initial test run

We recommend doing an initial test run to familiarize yourself with the Air Fryer Duo 2 Flexzone and ensure that the unit is properly working. This will also help eliminate any residue or traces of odour from the unit that may remain after shipping.

## NOTE:

- This process must be done with **NO** food inside the unit.

## Step 1: Insert Cooking Trays

- **DO NOT** install divider.

## Step 2: Power On

- Plug the air fryer into a power outlet.
- Turn on the air fryer by pressing the **POWER** button.

## Step 3: Select DUAL COOK

- Press **DUAL COOK**. This seamlessly duplicates the program and settings across zones for unified cooking.

## Step 4: Select AIR FRY, Adjust Time and Temperature

- Press **AIR FRY**. The program blinks and display shows the default settings.
- Press **TIME** button and turn the knob counter clockwise to adjust the time to 5 minutes.
- Keep the temperature at **200°C**.

## Step 5: Starting Initial Test Run

- After all settings are adjusted, press the **START** button to begin.
- The unit enters preheating cycle. Press **SKIP PREHEAT** to proceed directly with the cooking cycle.

- Halfway through the initial test run time, **SHAKE** appears on display. Just open and close the basket. Unit resumes with the remaining time.

## Step 6: Initial Test Run Completion

- When the time is up, the unit will display **ENJOY**.  
**Note: After cooking, the unit's fan will continue running for about 30 seconds to cool down the interior.**
- Allow unit to cool.

**You're all set. Happy cooking!**

# Cooking

The Air Fryer Duo 2 Flexzone features twin heating elements, an extra-large 8.5L basket which can be divided into two independent zones enabling simultaneous cooking of two different meals in one go.

## ⚠ WARNING!

- **DO NOT** touch hot surfaces and accessories during or immediately after cooking. The air fryer and its accessories become extremely hot during the cooking process. **AVOID** physical contact with hot parts. **ALWAYS** wear proper hand protection when handling hot materials to avoid burns and serious physical injury. Allow accessories to completely cool before cleaning.
- **DO NOT** overfill the air fryer basket with food. Excessive amount of food may touch the heating element and can cause a fire hazard.
- **DO NOT** place oversized foods and metal utensils into the air fryer.
- **DO NOT** block the air vents.
- **DO NOT** cover the air fryer with anything. **DO NOT** put anything on top of the appliance.
- **DO NOT** leave the appliance unattended during use.
- **ALWAYS** use oven mitts or heat-resistant gloves, as well as tongs to flip, shake or when taking out your food. Be extremely careful as the unit and the cooked foods are very hot.

## AIR FRY

Setting	Default	Adjustable Range	Minimum	Maximum	Increment	AUTOMATIC PREHEATING	SHAKE REMINDER
Temperature	200°C	75°C-200°C	75°C	200°C	+/- 5°C	YES	YES
Cooking Time	00:10 (10 minutes)	00:01 - 01:00	1 minute	1 hour	+/- 1 min		

## AIR FRY PRESETS

Pre-programmed air fry functions for specific food.

	Setting	Default	Adjustable Range	Minimum	Maximum	Increment	AUTOMATIC PREHEATING	SHAKE REMINDER
FRIES	Temperature	180°C	75°C-200°C	75°C	200°C	+/- 5°C	YES	YES
	Cooking Time	00:14 (14 minutes)	00:01 - 01:00	1 minute	1 hour	+/- 1 min		
CHICKEN	Temperature	190°C	75°C-200°C	75°C	200°C	+/- 5°C	YES	YES
	Cooking Time	00:25 (25 minutes)	00:01 - 01:00	1 minute	1 hour	+/- 1 min		

	Setting	Default	Adjustable Range	Minimum	Maximum	Increment	AUTOMATIC PREHEATING	SHAKE REMINDER
BURGER	Temperature	200°C	75°C-200°C	75°C	200°C	+/- 5°C	YES	YES
	Cooking Time	00:20 (20 minutes)	00:01 - 01:00	1 minute	1 hour	+/- 1 min		
STEAK	Temperature	200°C	75°C-200°C	75°C	200°C	+/- 5°C	YES	YES
	Cooking Time	00:06 (06 minutes)	00:01 - 01:00	1 minute	1 hour	+/- 1 min		
FISH	Temperature	200°C	75°C-200°C	75°C	200°C	+/- 5°C	YES	YES
	Cooking Time	00:10 (10 minutes)	00:01 - 01:00	1 minute	1 hour	+/- 1 min		
SAMOSA	Temperature	180°C	75°C-200°C	75°C	200°C	+/- 5°C	YES	YES
	Cooking Time	00:12 (12 minutes)	00:01 - 01:00	1 minute	1 hour	+/- 1 min		

## BAKE

Setting	Default	Adjustable Range	Minimum	Maximum	Increment	AUTOMATIC PREHEATING	SHAKE REMINDER
Temperature	150°C	75°C-200°C	75°C	200°C	+/- 5°C	YES	NO
Cooking Time	00:30 (30 minutes)	00:01 - 01:00	1 minute	1 hour	+/- 1 min		

## ROAST

Setting	Default	Adjustable Range	Minimum	Maximum	Increment	AUTOMATIC PREHEATING	SHAKE REMINDER
Temperature	200°C	75°C-200°C	75°C	200°C	+/- 5°C	YES	NO
Cooking Time	00:15 (15 minutes)	00:01 - 01:00	1 minute	1 hour	+/- 1 min		

## BROIL

Setting	Default	Adjustable Range	Minimum	Maximum	Increment	AUTOMATIC PREHEATING	SHAKE REMINDER
Temperature	200°C	75°C-200°C	75°C	200°C	+/- 5°C	YES	NO
Cooking Time	00:20 (20 minutes)	00:01 - 01:00	1 minute	1 hour	+/- 1 min		

## REHEAT

Setting	Default	Adjustable Range	Minimum	Maximum	Increment	AUTOMATIC PREHEATING	SHAKE REMINDER
Temperature	170°C	75°C-200°C	75°C	200°C	+/- 5°C	NO	NO
Cooking Time	00:15 (15 minutes)	00:01 - 01:00	1 minute	1 hour	+/- 1 min		

## DEHYDRATE

Setting	Default	Adjustable Range	Minimum	Maximum	Increment	AUTOMATIC PREHEATING	SHAKE REMINDER
Temperature	50°C	35°C-80°C	35°C	80°C	+/- 5°C	NO	NO
Cooking Time	08:00 (8 hours)	01:00 - 24:00	1 hour	24 hour	+/- 15 min		

# Single Zone Cooking

Allows flexibility for cooking smaller batches of food using only one of the zones.

### Step 1: Insert Cooking Trays and Install Divider

#### Step 2: Power On

- Plug the air fryer into a power outlet.
- Turn on the air fryer by pressing the **POWER** button.

### Step 3: Selecting a Cooking Program, Adjusting Cooking Time and Temperature

- Press either basket 1 or 2.
- Select a cooking program by directly pressing the button.
- To adjust the time, press **TIME** button. Turn knob clockwise to increase or counter clockwise to decrease the cooking time.

- To adjust the temperature, press **TEMP** button. Turn knob clockwise to increase or counter clockwise to decrease the cooking temperature.

#### Step 4: Cooking Cycle

- After all settings are adjusted, press the **START** button to begin.
- The unit enters preheating cycle (depending on the cooking program).

**Note: Optionally, you can bypass preheating by pressing the SKIP PREHEAT button to proceed directly with cooking.**

- After preheating, display shows **ADD FOOD**. Open basket and add ingredients on the selected zone.
- Close basket. Unit enters cooking cycle and display shows the countdown time.
- Halfway through the cooking time, **SHAKE** appears on display. Open basket and shake or flip food. Refer to Shaking section in this user guide for more information.

#### Step 5: Cooking Completion

- When the cooking time is up, the unit will display **ENJOY**.  
**Note: After cooking, the unit's fan will continue running for about 30 seconds to cool down the interior.**
- Open basket and carefully transfer food using a silicone-tipped tong.

# Dual Zone Cooking using SYNC FINISH

Allows you to cook two different foods simultaneously using two different cooking programs and settings and have them finish at the same time.

### Step 1: Insert Cooking Trays and Install Divider

#### Step 2: Power On

- Plug the air fryer into a power outlet.
- Turn on the air fryer by pressing the **POWER** button.

### Step 3: Selecting a Cooking Program, Adjusting Cooking Time and Temperature for First Zone

- Press basket 1.
- Select a cooking program by directly pressing the button.
- To adjust the time, press **TIME** button. Turn knob clockwise to increase or counter clockwise to decrease the cooking time.
- To adjust the temperature, press **TEMP** button. Turn

knob clockwise to increase or counter clockwise to decrease the cooking temperature.

### Step 4: Selecting a Cooking Program, Adjusting Cooking Time and Temperature for Second Zone

- Repeat Step 3 for basket 2.

#### Step 5: Syncing Cooking Time

- After all settings for both zones are adjusted, press **SYNC FINISH**.

#### Step 6: Cooking Cycle

- Press the **START** button to begin.
- The unit enters preheating cycle (depending on the cooking program).

**Note: Optionally, you can bypass preheating by pressing the SKIP PREHEAT button to**

**proceed directly with the cooking cycle.**

- After preheating, display shows **ADD FOOD**. Open basket and add ingredients on the zone that finished preheating. If the other zone is still preheating, do not add food yet. Add ingredients only when the **ADD FOOD** is displayed.
- Close basket. Unit enters cooking cycle and display shows the countdown time.
- The zone that has the longer cooking time will start cooking first and the other zone will be on **ON HOLD**. Once the cooking time syncs for both zones,

display will show the same countdown time.

- Halfway through the cooking time, **SHAKE** appears on display (depending on the cooking program). Open basket and shake or flip food. Refer to Shaking section in this user guide for more information.

#### Step 7: Cooking Completion

- When the cooking time is up, the unit displays **ENJOY**.  
**Note: After cooking, the unit's fan will continue running for about 30 seconds to cool down the interior.**
- Open basket and carefully transfer food using a silicone-tipped tong.

#### Step 5: Cooking Time

- Press the **START** button to begin cooking.
- The unit enters preheating cycle (depending on the cooking program).

**Note: Optionally, you can bypass preheating by pressing the SKIP PREHEAT button to proceed directly with the cooking cycle.**

- After preheating, display shows **ADD FOOD**. Open basket and add ingredients on the zone that finished preheating. If the other zone is still preheating, do not add food yet. Add ingredients only when the **ADD FOOD** is displayed.
- Close basket. Unit enters cooking cycle and display shows the countdown time.
- Halfway through the cooking time, **SHAKE**

appears on display (depending on the cooking program). Open basket and shake or flip food. Refer to Shaking section in this user guide for more information.

#### Step 6: Cooking Completion

- The zone that has the shorter cooking time will finish first while the other zone with the longer cooking time continues to cook.
- When the cooking time is up in each zone, the unit displays **ENJOY**.  
**Note: After cooking, the unit's fan will continue running for about 30 seconds to cool down the interior.**
- Open basket and carefully transfer food using a silicone-tipped tong.

## Dual Zone Cooking but ending at different times

Allows you to cook two different foods simultaneously using two different cooking programs and settings and will finish in different times.

#### Step 1: Insert Cooking Trays and Install Divider

#### Step 2: Power On

- Plug the air fryer into a power outlet.
- Turn on the air fryer by pressing the **POWER** button.

#### Step 3: Selecting a Cooking Program, Adjusting Cooking Time and Temperature for First Zone

- Press basket 1.
- Select a cooking program by directly pressing the button.

- To adjust the time, press **TIME** button. Turn knob clockwise to increase or counter clockwise to decrease the cooking time.
- To adjust the temperature, press **TEMP** button. Turn knob clockwise to increase or counter clockwise to decrease the cooking temperature.

#### Step 4: Selecting a Cooking Program, Adjusting Cooking Time and Temperature for Second Zone

- Repeat Step 3 for basket 2.

## Ultra Zone Cooking

Remove the divider to use the 8.5L extra-large basket, perfect for big batch cooking. The 8.5L Full-sized basket is ideal for large portions and family-sized meals.

#### Step 1: Insert Cooking Trays

- **DO NOT** install divider.

#### Step 2: Power On

- Plug the air fryer into a power outlet.
- Turn on the air fryer by pressing the **POWER** button.

#### Step 3: Select DUAL COOK

- To activate Ultra Zone cooking, press **DUAL COOK**. This seamlessly

duplicates the program and settings across zones for unified cooking.

#### Step 4: Selecting a Cooking Program, Adjusting Cooking Time and Temperature

- Select any of the cooking programs by directly pressing the button. The default settings are displayed on both zones.
- To adjust the time, press **TIME** button. Turn knob

clock wise to increase or counter clockwise to decrease the cooking time.

- To adjust the temperature, press **TEMP** button. Turn knob clock wise to increase or counter clockwise to decrease the cooking temperature.

#### Step 5: Cooking Cycle

- Press the **START** button to begin.
- The unit enters preheating cycle (depending on the cooking program).

**Note: Optionally, you can bypass preheating by pressing the SKIP PREHEAT button to proceed directly with cooking.**

- After preheating, display shows **ADD FOOD**.

#### SHAKING FOOD

During the cooking process, shake the basket or flip your food for even cooking and browning. **AIR FRY** program and all **PRESETS** have the automatic **SHAKE** reminder function that is activated halfway through cooking. It is recommended to shake the basket or flip your food once or more, if desired.

#### ⚠ CAUTION:

- **Always** be careful of hot steam when pulling the air fryer basket from the unit.

1. Hold the air fryer basket just above a heat resistant surface and shake it or flip food carefully.

**Note:** When cooking naturally high fat foods, flip the food using a silicone-tipped tong. **DO NOT** shake the basket to avoid risk of hot liquids splashing.

2. Depending on the food, the basket might be too heavy to shake. In this case, ensure to place the Air Fryer basket on a stable and heat-resistant surface then shake it or flip food carefully. If basket won't shake because of the weight,

Open basket and add ingredients.

- Close basket. Unit enters cooking cycle and display shows the countdown time.
- Halfway through the cooking time, **SHAKE** appears on display (depending on the cooking program). Open basket and shake or flip food. Refer to Shaking section in this user guide for more information.

#### Step 6: Cooking Completion

- When the cooking time is up, the unit displays **ENJOY**.

**Note: After cooking, the unit's fan will continue running for about 30 seconds to cool down the interior.**

- Open basket and carefully transfer food using a silicone-tipped tong.

use a silicone-tipped tong instead.

#### ⚠ WARNING!

- For safety purposes, it is recommended to use silicone-tipped tongs to flip food that contains oil or any hot liquids. Any excess oil and liquids can splash from the basket when shaking.

- Always drain any excess oil or hot liquids from the air fryer basket. Excess oil may produce extra smoke when heated for longer period.

## Care & maintenance

#### ⚠ WARNING!

- To avoid electric shock or damage to your air fryer, **ALWAYS** press the **POWER** button to turn the unit **OFF** and unplug from the power supply outlet before cleaning.
- The air fryer and its accessories can reach high temperatures during operation and remains hot even after use. **AVOID** touching the heating elements, interior & exterior surfaces, and accessories. Make sure that all parts and accessories of your air fryer have cooled down completely.
- **DO NOT** immerse the power cord or the unit in water or any other liquids.
- **DO NOT** clean with metal scouring pads. Metal fragments can break off the pad and touch electrical parts, creating a risk of electric shock.

#### ⚠ CAUTION!

- **DO NOT** use abrasive cleaners, steel wool, or scouring pads.
- Dry all parts and accessories thoroughly after cleaning, before using, or before storing your air fryer.
- Make sure that all parts and surfaces are completely dry before connecting your air fryer to a power outlet. Wet parts can cause electric shock.
- **ALWAYS** clean your air fryer thoroughly after every use.
- **DO NOT** store anything on top of the air fryer.
- **DO NOT** store anything inside the air fryer other than the included accessories.

Parts and Accessories	Cleaning method and tips
Air Fryer Base Control Panel	<ul style="list-style-type: none"> <li>• Wipe the exterior surfaces of the air fryer with a <b>SOFT</b> and barely damp cloth. Dry with a <b>SOFT</b> towel thoroughly.</li> <li>• Wipe the outer surface of the control panel with a <b>SOFT</b> and barely damp cloth. Dry with a soft towel to prevent water spots and streaks. <b>DO NOT</b> use abrasive cleanser or metal scouring pads as this will cause scratches in the control panel.</li> <li>• <b>⚠ WARNING: DO NOT</b> submerge the unit in water or any other liquids.</li> <li>• <b>After cleaning, ensure all surfaces are dry by gently wiping them with a soft dry cloth before using the air fryer.</b></li> </ul>
Plug and Cord	<ul style="list-style-type: none"> <li>• <b>REGULARLY</b> inspect the plug and cord for any signs of damage or wear. If you notice any fraying, exposed wires, or other issues, refrain from using the appliance until it's repaired or replaced by Nutricook's authorized technician. To clean the plug and cord, gently wipe them with a dry cloth.</li> <li>• <b>⚠ WARNING: NEVER</b> immerse the plug and cord in water or any other liquid to prevent electrical hazards.</li> <li>• <b>ALWAYS</b> hold the plug when unplugging the air fryer. <b>AVOID</b> pulling the cord, which can lead to damage.</li> </ul>

<b>Air Fryer Basket</b>	<ul style="list-style-type: none"> <li>Wash them with warm soapy water and a non-abrasive sponge or cloth. Ensure baked-on grease and food debris/residue are removed.</li> </ul>
<b>Cooking Trays and Rubber Stoppers</b>	<ul style="list-style-type: none"> <li>For stubborn stains or residues, soak the air fryer basket, divider and cooking trays in warm soapy water for a few minutes before cleaning.</li> </ul>
<b>Divider</b>	<ul style="list-style-type: none"> <li>Rinse thoroughly and allow these accessories to dry before inserting them in the air fryer.</li> <li><b>NOTE:</b> The air fryer basket, cooking trays and divider have a non-stick coating, to <b>AVOID</b> damage on the non-stick coating, <b>NEVER</b> use steel wool, abrasive pads, or harsh cleaning chemicals.</li> <li><b>We recommend handwashing these accessories for longer life span.</b></li> </ul>



**⚠ WARNING: DO NOT** immerse air fryer in water.

# Troubleshooting

Issue	Possible Cause	Solution
Air Fryer will not turn on	Unit is not plugged in.	Plug in unit to an electrical outlet. <b>DO NOT</b> use the unit in locations with different electrical specifications or plug types. Press <b>POWER</b> (⏻) to turn it on.
<b>CLOSE BASKET</b> appears on the display	The air fryer basket is open.	Close air fryer basket. When cooking, closing the air fryer basket after it was opened will resume cooking cycle.
Food is undercooked	Air fryer basket is overloaded.	<b>DO NOT</b> overfill the air fryer basket with food. Overfilling will result to uneven cooking. It is recommended to fry smaller batches of food as this will allow proper air circulation for even cooking and browning. It is recommended to shake the basket or flip your food once or more, as desired to check for doneness. This will also allow even cooking and browning.
White smoke is coming out from the unit	Excess oil and naturally high fat foods may produce white smoke while cooking.	This is normal. It is recommended to empty oils or fats accumulated in the cooking pot between batches of cooking to avoid excess smoke.
	The air fryer basket and cooking tray have not been cleaned from previous use.	Follow care and maintenance instruction to clean accessories and remove dried food debris or grease after every use.
	Using oil with low smoke point such as olive oil may produce excess smoke.	Use oil with high smoke point such as avocado, canola or grapeseed oil.
Black smoke is coming out from the unit	Food is burning.	Immediately turn off the unit and unplug. Wait for smoke to stop before opening the air fryer basket. Clean all accessories thoroughly.
	There is a circuit problem.	Immediately turn off the unit and unplug. Wait for smoke to stop before opening the air fryer basket. Contact customer service for assistance. <b>⚠ WARNING: DO NOT</b> attempt to use the unit.
Unit displays any of the following error codes: E1, E2, E3, E4, E5, E6, E7, E8, E9, E10, E11	Faulty device. Unit not working.	<b>⚠ WARNING:</b> Stop using the unit when these error codes appear. Disconnect from power supply and contact Customer Service immediately.

**NOTE:** If you encounter any issue which is not listed above, contact Customer Service at **800-NUTRI (68874)** or email **support@nutricookworld.com** for assistance.

# Warranty

## LIMITED WARRANTY FOR NUTRICOOK

Nutricook's limited warranty obligations are confined to the terms set forth below:

Nutricook warrants this product against defects in materials and workmanship for a period of **two years** from the date of original retail purchase. This limited warranty is valid only in the country in which the product is purchased and comes with the product at no extra charge, however shipping and processing fees will be incurred for returns, replacements and or refunds.

## OBTAINING WARRANTY SERVICE

For limited warranty service, simply visit [www.nutricookworld.com](http://www.nutricookworld.com) for Customer Service details of your respective territory or contact our customer service department at [support@nutricookworld.com](mailto:support@nutricookworld.com) and we will be glad to help you. When you contact our customer service department you will be asked for your name, address, telephone number and to provide proof of the original purchase (receipt) containing a description of the product(s), purchase date, and the appropriate Nutricook bar code(s). Before you send your product for limited warranty service please make sure to keep a copy of all relevant documents for your files (receipt, etc.). It is always recommended to purchase product insurance and tracking services when sending your product for service. Remember, shipping and processing fees will be incurred and are not covered by the two-year limited warranty.

## EXCLUSIONS AND LIMITATIONS

This **Nutricook Two-Year Limited Warranty** applies only to Nutricook products distributed by or for Nutricook that can be identified by the "Nutricook" trademark, trade name, logo and bar code.

**Nutricook's Two-Year Limited Warranty** does not apply to any other products that may appear to be authentic, but were not distributed/sold by Nutricook.

Normal wear and tear is not covered by this limited warranty.

This limited warranty applies to consumer use only, and is void when the product is used in a commercial or institutional setting.

This limited warranty extends only to the original consumer purchaser and is not transferable. In addition, proof of purchase must be demonstrated.

Repair or replacement of the product (or, if repair or replacement is not feasible, a refund of the purchase price) is the exclusive remedy of the consumer under this limited warranty. Nutricook shall not be liable for any incidental or consequential damages for breach of this limited warranty or any implied warranty on this product.

This limited warranty does not apply:

- (a) to damage caused by accident, abuse, misuse, or misapplication;
- (b) to damage caused by improper maintenance (including unauthorized parts service);
- (c) to a product or a part that has been modified in any way;
- (d) if any Nutricook bar code or trademark has been removed or defaced; and
- or (e) if the product has been used with an adapter/converter.

THIS LIMITED WARRANTY AND THE REMEDIES SET FORTH ABOVE ARE EXCLUSIVE AND IN LIEU OF ALL OTHER WARRANTIES, REMEDIES AND CONDITIONS, WHETHER ORAL OR WRITTEN, EXPRESS OR IMPLIED. NUTRICOOK SPECIFICALLY DISCLAIMS ANY

AND ALL IMPLIED WARRANTIES, INCLUDING, WITHOUT LIMITATION, WARRANTIES OF MERCHANTABILITY AND FITNESS FOR A PARTICULAR PURPOSE. IF NUTRICOOK CANNOT LAWFULLY DISCLAIM IMPLIED WARRANTIES UNDER THIS LIMITED WARRANTY, ALL SUCH WARRANTIES, INCLUDING WARRANTIES OF MERCHANTABILITY AND FITNESS FOR A PARTICULAR PURPOSE ARE LIMITED IN DURATION TO THE DURATION OF THIS LIMITED WARRANTY. No Nutricook reseller, agent, or employee is authorized to make any modification to this warranty.

NUTRICOOK IS NOT RESPONSIBLE FOR DIRECT, SPECIAL, INCIDENTAL OR CONSEQUENTIAL DAMAGES RESULTING FROM ANY BREACH OF WARRANTY OR CONDITION, OR UNDER ANY OTHER LEGAL THEORY, INCLUDING BUT NOT LIMITED TO LOST PROFITS, DOWNTIME, GOODWILL, DAMAGE TO OR REPLACEMENT OF EQUIPMENT AND PROPERTY. NUTRICOOK SPECIFICALLY DOES NOT REPRESENT THAT IT WILL BE ABLE TO REPAIR ANY PRODUCT UNDER THIS LIMITED WARRANTY.



## **AIR FRYER DUO 2 FLEXZONE**

Model No. AFD285

nutricook. | [www.nutricookworld.com](http://www.nutricookworld.com) | All rights reserved.

Illustrations may differ from the actual product. We are constantly striving to improve our products, therefore the specifications contained herein are subject to change without notice.

Nutricook is a registered trademark of Caliber Brands FZE.

AFD285\_Series\_UG\_V1.202308