



Gas Countertop Griddle

Instruction Manual

This manual contains important information regarding your purchased equipment. Please read the manual thoroughly prior to equipment set-up, operation and maintenance.

Failure to comply with regular maintenance guidelines outlined in this manual may void the warranty. Please keep it for future reference after installation and do not throw it away!

This is a universal installation and operation instruction book which would apply to different models.

PLEASE READ!!!

Model: EGG-16SX/EGG-24SX/EGG-36SX/EGG-48SX/EGG-60SX

Please read this instruction manual carefully before operating this equipment

WARNINGS

- Do not store or use gasoline or other flammable vapors or liquids in the vicinity of this or any other equipment.
- Improper installation, adjustment, alteration, service or maintenance can cause property damage, injury or death.
- Read the installation and maintenance instructions thoroughly before installing or servicing this equipment.
- Have the equipment installed by a qualified installer in accordance with all federal, state and local codes.
- Do not install or use without all 4 legs.
- This equipment is for use in non-combustible locations only.
- Do not obstruct the flow of combustion and ventilation air.
- Do not spray controls or the outside of the equipment with liquids or cleaning agents
- Allow for hot parts to cool before cleaning or moving.
- This equipment should only be used in a flat, level position.
- Do not operate unattended.
- Any loose dirt or metal particles that are allowed to enter the gas lines on this equipment will damage the valve and affect its operation.
- If you smell gas, follow the instructions provided by the gas supplier. Do not touch any electrical switch; do not try to light the burner; do not use a telephone within close proximity.
- Never attempt to move grates while cooking.

SET UP

1. Remove all packing material and tape, as well as any protective plastic from the equipment.
2. Place the equipment in the desired position and height.
3. Install the four (4) legs onto the equipment.
4. Clean and dry the equipment thoroughly before using.

INSTALLATION:

- The equipment and its individual shutoff valve must be disconnected from the gas supply piping system during any pressure testing of that system at test pressures in excess of ½ psi (3.5 kPa).
- The equipment must be isolated from the gas supply piping system by closing its individual manual shutoff valve during any pressure testing of the gas supply piping system at test pressures equal to or less than ½ psi (3.5 kPa).

Clearance and positioning around the equipment:

- This equipment must be installed adjacent to non-combustible surfaces only with a minimum spacing of 6" from all sides. This equipment must be a distance of 6" from other equipment. The equipment must have the 4" legs installed and be placed on a noncombustible surface.

Air Supply and ventilation:

- The area in front and around the equipment must be kept clear to avoid any obstruction of the flow of combustion and ventilation air.
- Adequate clearance must be maintained at all times in front of and at the sides of the equipment for servicing and proper ventilation.

PROPANE GAS CONVERSION

This griddle is shipped from the factory equipped with fixed burner orifices for natural gas operation. The burner orifices required to convert the griddle to propane gas. It is recommended that a trained gas service technician with the necessary tools, instruments and skills perform the conversion.

To convert to propane, following steps must be completed:

1. Remove all natural gas burner orifices and install the provided propane burner orifices.
2. Set the regulator to 37mba.

LIGHTING THE PILOT:

The manifold units are equipped with standing pilots and each should be lit immediately after the gas is supplied to the equipment.

1. Before attempting to light the pilots, turn off the main gas valve to the equipment and wait 5 minutes to clear the gas.
2. Turn off all gas control knobs.
3. Turn on control valve and light all pilots.
4. The pilot burner must be lit from the top. Hold an ignition source and light the pilot. When the flame is stable, remove ignition source.
5. Turn off the main gas valve to shut down the equipment.

Smoke appearing on initial start of the equipment is normal. This is a result of the painted coating burning off. Allow the equipment to "burn in" for at least 20 minutes before the first use.

Pilot Flame Height Adjustment:

- The pilot flame on the equipment has been factory adjusted. When adjustment is necessary, adjust the pilot flames as small as possible but high enough to light the burner immediately when the burner valve is turned to the highest setting. Access to the pilot flame adjustment screw is obtained through the holes in the front panel

Burner Adjustment:

- Remove the front panel to gain access. Turn burner valve knob to highest setting. Slowly decrease the air shutters to give a soft blue flame having luminous tips. Then slowly increase opening to a point where the yellow tips disappear and a hard blue flame is obtained.

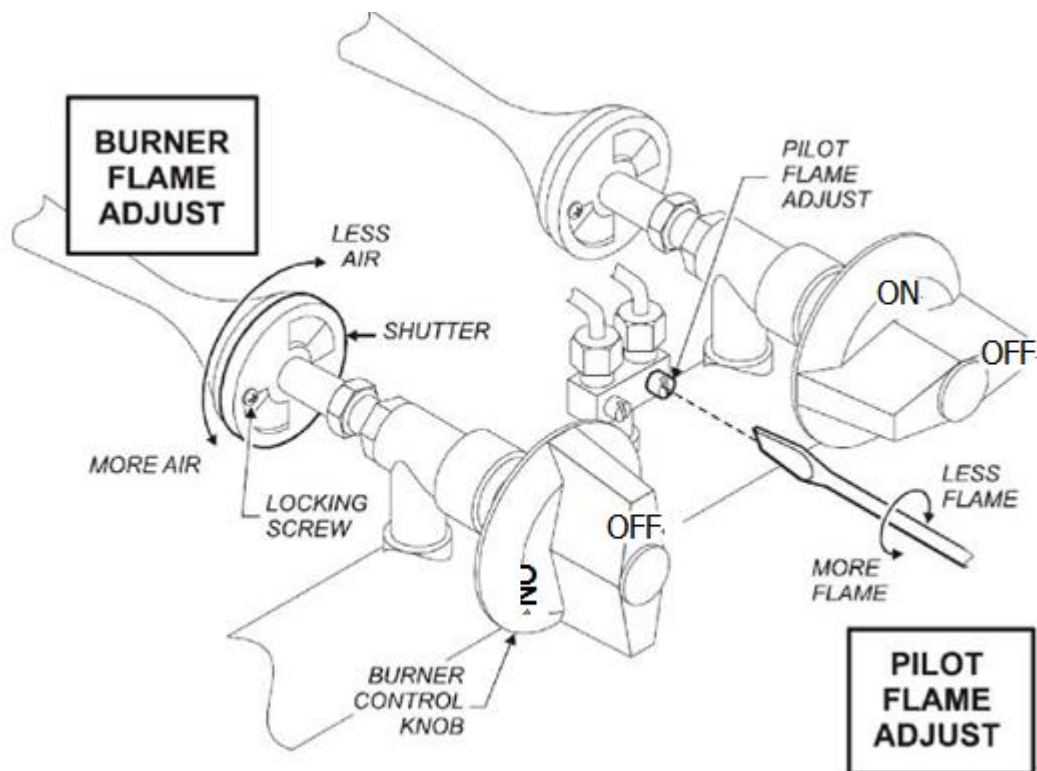

OPERATION:

Before initial use, turn the gas control knob to the maximum setting and allow the equipment to burn-in for 20 minutes.

Seeing smoke coming from the cooking surface is normal during burn-in. After 20 minutes of burn-in, equipment is ready for use.

1. To ignite the burners, depress and turn the gas control knob to high position.
2. After cooking is done, please turn the valve to off position.

For thermostatic controlled griddle, the operation procedure is same.

MAINTENANCE:

- A qualified service company should check the unit for safe and efficient operation on an annual basis.
- Gas piping shall be a certain size and installed to provide a supply of gas sufficient to meet the full gas input of the equipment.
- A manual shut off valve should be installed upstream from the manifold within 4 ft. (1.2m) of the equipment and in a position where it can be reached in the event of an emergency.
- Check entire gas piping system for leaks every so often. Using a gas leak detector or soapy water solution is recommended.
- Install equipment under efficient exhaust hood with flameproof filters with a distance of no less than 4 feet between the top of the equipment and the filters or any other combustible materials.

*Shipped setup for Natural Gas and includes a kit for conversion to LPG.

SEASONING THE GRIDDLE

Season the griddle to avoid possible surface corrosion before first use, and after every cleaning. Heat griddle to a low temperature (300-350°F) and apply a small amount of cooking oil – about one ounce per square foot of surface. Use a soft lint-free cloth to spread the oil over the entire griddle surface to create a thin film. Wipe off any excess oil with a cloth. Repeat the procedure until the griddle has a slick, mirror-like finish. This will also help reduce the sticking of cooked food product.

USING THE GRIDDLE

To preheat, turn the burners on about 20-25 minutes before cooking.

A uniform and systematic approach to loading the griddle will produce the most consistent product results.

The griddle plate is steel, but the surface is relatively soft and can be scored or dented by careless use of a spatula or scraper. Be careful not to dent, scratch, or gouge the plate surface. Do not try to knock off loose food that may be on the spatula by tapping the corner or the edge of the spatula on the griddle surface.

CLEANING THE GRIDDLE

Empty the grease drawer as needed throughout the day and regularly clean at least once daily.

Clean the griddle regularly. A clean griddle always looks better, lasts longer and performs better. To produce evenly cooked, perfectly browned griddle products keep the griddle plate clean and free of carbonized grease. Carbonized grease on the surface hinders the transfer of heat from the griddle surface to the food, resulting in spotty browning and loss of cooking efficiency. Carbonized grease tends to cling to griddle foods, giving them a highly unsatisfactory and unappetizing appearance.

To keep the griddle clean and operating at peak efficiency, follow these procedures:

AFTER EACH USE

Clean the griddle with a wire brush or flexible spatula.

ONCE PER DAY

Thoroughly clean the griddle back splash, sides and front. Remove, empty and wash the grease drawer in the same manner as an ordinary cooking utensil.

ONCE PER WEEK

Clean the griddle surface thoroughly. Use a griddle stone, screen, or Scotch Bright pad on the surface as necessary. Rub with the grain of the metal while the griddle is still warm (not hot). A detergent may be used on the plate surface to help clean it, but be sure the detergent is thoroughly removed by flushing with clear water.

After removal of detergent the surface of the plate the griddle should be seasoned according to the instructions in this manual.

Clean stainless steel surfaces with a damp cloth and polish with a soft dry cloth. To remove discoloration, use a griddle cleaner.

If the griddle usage is very high, consider conducting this weekly cleaning procedure more than once per week.

LEVELING

The griddle must be level (side-to-side and front-to-back) during operation to ensure proper performance. Improper leveling can result in uneven temperature distribution, cold spots, and possibly damaged components.

1. Place a level on the griddle.
2. Adjust legs by turning the bullet feet at the bottom of each leg. Using pliers or a crescent wrench, turn the feet counter-clockwise to increase height, and clockwise to decrease height until leveling is achieved. Do not extend the legs more than 1-³/₄".

PROBLEM	POSSIBLE CAUSES
Burner does not come on when the control knob is turned on	1. Problem with gas valve. (Call for service) 2. Pilot burner not lit. (Call for service) 3. Low gas pressure. (Call for service)
Pilot burner will not light	1. Manual gas valve not turned on. 2. Obstructed pilot orifice. (Call for service) 3. Pilot gas turned off at pilot. Adjust pilot to allow gas flow. 4. Low gas pressure. (Call for service)
Pilot burner will not stay lit	1. Obstructed or wrong size pilot orifice. (Call for service) 2. Gas supply not purged of air. Open pilot valve until air is purged. 3. Air blowing pilot out. (Call for service) 4. Low gas pressure. (Call for service)
Fat appears to smoke excessively	1. Temperature set too high. 2. Moisture in food may be turning into steam
Food sticks to griddle or burned around edges	1. Temperature set too high. 2. Griddle surface requires cleaning and/or seasoning. 3. Surface under food not covered with enough cooking oil.
Food under-cooked inside	1. Temperature set too low. 2. Food not cooked for long enough time.
Food tastes greasy or has objectionable off-flavor	1. Food itself may have off-flavor. 2. Food stored improperly before cooking. 3. Too much griddle fat used. 4. Temperature set too low.
Noticeable build-up of gum on griddle	1. Temperature set too high. 2. Griddle surface needs cleaning and/or seasoning. 3. Too much griddle fat used.

Product Specification Sheet

MODEL	STYLE(Manual)	Total Power input(kW) per Hour
EGG-16SX	Single Burner w/ individual control	7
EGG-24SX	2 Burners w/ individual control	14
EGG-36SX	3 Burners w/ individual control	21
EGG-48SX	4 Burners w/ individual control	28
EGG-60SX	5 Burners w/ individual control	35

WARRANTY

Cateryard warrants to the original purchaser of every new product, under normal and proper use and maintenance service as specified by Cateryard and upon proper installation and start-up in accordance with the instruction packet supplied with each unit. Cateryard's obligation under this warranty is limited to a period of one (1) year from the date of original installation.

WARRANTY CLAIMS

All claims for parts must be made directly through Cateryard. All claims should include:

Personal Details:

Your name:

Your company:

Address:

Email:

Phone:

Products Details:

Model number:

Serial number of the product:

Date of purchase:

Proof of purchase :

Pertinent information supporting the existence of the alleged defect.(Such as picture etc.)

Please send the above information to sales@cateryard.co.uk

Our warranty departments will according to the actual situation and reply you within 24hours.



Cateryard Limited

www.cateryard.co.uk