



Gas Countertop Charbroiler

Instruction Manual

This manual contains important information regarding your purchased equipment. Please read the manual thoroughly prior to equipment set-up, operation and maintenance.

Failure to comply with regular maintenance guidelines outlined in this manual may void the warranty. Please keep it for future reference after installation and do not throw it away!

This is a universal installation and operation instruction book which would apply to different models.

PLEASE READ!!!

Model: ECB-16SX/ECB-24SX/ECB-36SX/ECB-48SX/ECB-60SX

Please read this instruction manual carefully before operating this equipment

WARNINGS

- Do not store or use gasoline or other flammable vapors or liquids in the vicinity of this or any other equipment.
- Improper installation, adjustment, alteration, service or maintenance can cause property damage, injury or death.
- Read the installation and maintenance instructions thoroughly before installing or servicing this equipment.
- Have the equipment installed by a qualified installer in accordance with all federal, state and local codes.
- Do not install or use without all 4 legs.
- This equipment is for use in non-combustible locations only.
- Do not obstruct the flow of combustion and ventilation air.
- Do not spray controls or the outside of the equipment with liquids or cleaning agents
- Allow for hot parts to cool before cleaning or moving.
- This equipment should only be used in a flat, level position.
- Do not operate unattended.
- Any loose dirt or metal particles that are allowed to enter the gas lines on this equipment will damage the valve and affect its operation.
- If you smell gas, follow the instructions provided by the gas supplier. Do not touch any electrical switch; do not try to light the burner; do not use a telephone within close proximity.
- Never attempt to move grates while cooking.

SET UP

1. Remove all packing material and tape, as well as any protective plastic from the equipment.
2. Place the equipment in the desired position and height.
3. Install the four (4) legs onto the equipment.
4. Clean and dry the equipment thoroughly before using.

INSTALLATION:

- The equipment and its individual shutoff valve must be disconnected from the gas supply piping system during any pressure testing of that system at test pressures in excess of ½ psi (3.5 kPa).
- The equipment must be isolated from the gas supply piping system by closing its individual manual shutoff valve during any pressure testing of the gas supply piping system at test pressures equal to or less than ½ psi (3.5 kPa).

Clearance and positioning around the equipment:

- This equipment must be installed adjacent to non-combustible surfaces only with a minimum spacing of 6" from all sides. This equipment must be a distance of 6" from other equipment. The equipment must have the 4" legs installed and be placed on a noncombustible surface.

Air Supply and ventilation:

- The area in front and around the equipment must be kept clear to avoid any obstruction of the flow of combustion and ventilation air.
- Adequate clearance must be maintained at all times in front of and at the sides of the equipment for servicing and proper ventilation.

PROPANE GAS CONVERSION

This char broiler is shipped from the factory equipped with fixed burner orifices for natural gas operation. The burner orifices required to convert the char broiler to propane gas. It is recommended that a trained gas service technician with the necessary tools, instruments and skills perform the conversion.

To convert to propane, following steps must be completed:

1. Remove all natural gas burner orifices and install the provided propane burner orifices.
2. Set the regulator to 37mba.

LIGHTING THE PILOT:

The manifold units are equipped with standing pilots and each should be lit immediately after the gas is supplied to the equipment.

1. Before attempting to light the pilots, turn off the main gas valve to the equipment and wait 5 minutes to clear the gas.
2. Turn off all gas control knobs.
3. Turn on control valve and light all pilots.
4. The pilot burner must be lit from the top. Hold an ignition source and light the pilot. When the flame is stable, remove ignition source.
5. Turn off the main gas valve to shut down the equipment.

There is one pilot for each burner. The charbroiler is equipped with standing, unmonitored pilots. Gas will flow from the pilots as soon as the main gas supply to the unit is turned on. Standing pilots should be adjusted to provide a slight yellow tip on the flame. Air shutters on the main burners must be individually adjusted to provide a blue flame. All traces of yellow should be adjusted out of the burner flame.

The charbroiler is a free vented appliance. All products of combustion and the heat generated by the burners pass through the grates. When meat is placed on the grates, this blocks the venting and causes a temperature build-up.

Pilot Flame Height Adjustment:

- The pilot flame on the equipment has been factory adjusted. When adjustment is necessary, adjust the pilot flames as small as possible but high enough to light the burner immediately when the burner valve is turned to the highest setting. Access to the pilot flame adjustment screw is obtained through the holes in the front panel

Burner Adjustment:

- Remove the front panel to gain access. Turn burner valve knob to highest setting. Slowly decrease the air shutters to give a soft blue flame having luminous tips. Then slowly increase opening to a point where the yellow tips disappear and a hard blue flame is obtained.

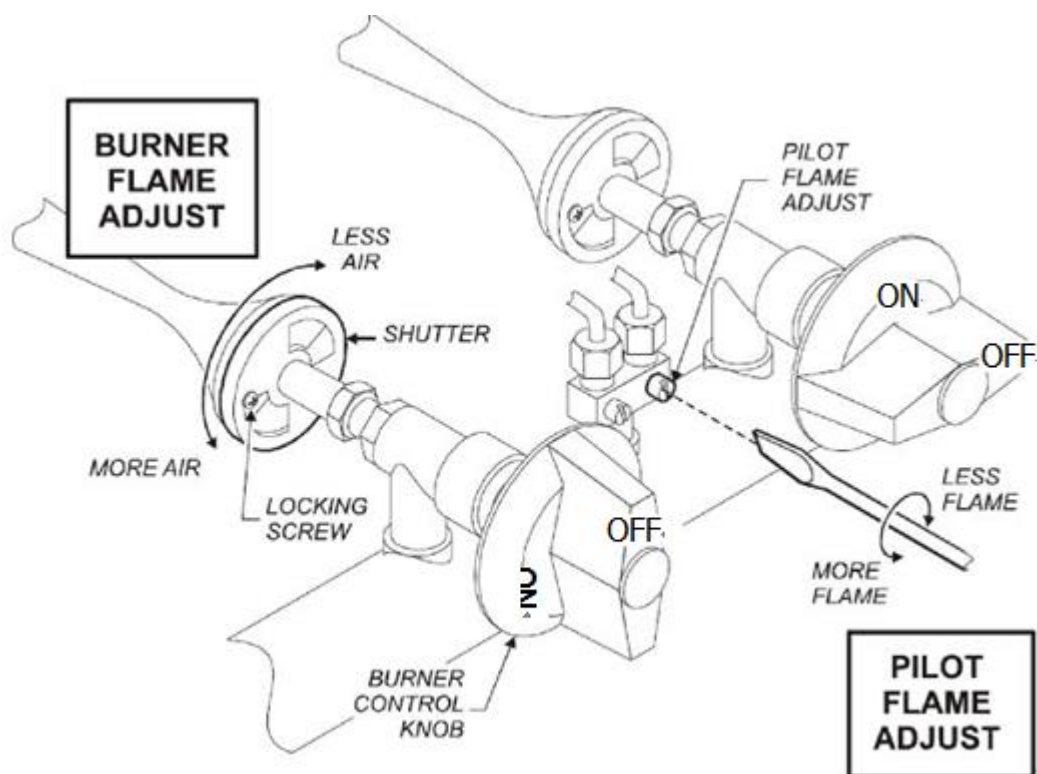

PREHEATING THE CHARBROILER:

Allow the charbroiler to preheat for 30 minutes. Rub grates with cooking oil before using. After 30 minutes of burn-in, equipment is ready for use.

OPERATION:

1. To ignite the burners, depress and turn the gas control knob to high position.
2. After cooking is done, please turn the valve to off position.

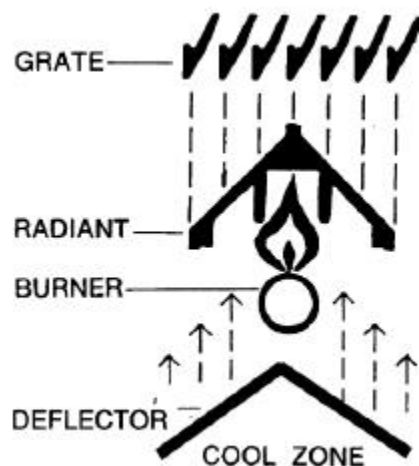

COMPONENT PARTS

The charbroiler comes with several standard parts as illustrated. Each can be easily removed and installed easily by hand for cleaning and maintenance. Note that the Burner and Deflector are an assembly and are NOT designed to be disassembled. Regarding the radiant cover, there are different

materials for different models. ECB series come with cold rolled steel material. The others come with cast iron material.

CLEANING

Scrape top grates during broiling with a wire brush to keep the grates clean. Do not allow debris to accumulate on the grates.

Top grates may be immersed in strong commercial cleaning compound overnight. In the morning, rinse with hot water to remove any residues of cleaning compound. Thoroughly dry and apply cooking oil to prevent rusting.

Stainless steel surfaces may be cleaned using damp cloth with mild detergent and water solution.

Places where fat, grease, or food can accumulate must be cleaned regularly

Never cover surface of unit with pans or other objects in attempt to “burn off” or clean debris from unit.

This will cause a buildup of heat that can potentially damage and warp components of the charbroiler.

MAINTENANCE:

- A qualified service company should check the unit for safe and efficient operation on an annual basis.
- Gas piping shall be a certain size and installed to provide a supply of gas sufficient to meet the full gas input of the equipment.
- A manual shut off valve should be installed upstream from the manifold within 4 ft. (1.2m) of the equipment and in a position where it can be reached in the event of an emergency.
- Check entire gas piping system for leaks every so often. Using a gas leak detector or soapy water solution is recommended.
- Install equipment under efficient exhaust hood with flameproof filters with a distance of no less than 4 feet between the top of the equipment and the filters or any other combustible materials.

*Shipped setup for Natural Gas and includes a kit for conversion to LPG.

LEVELING

It is important that the charbroiler is level front to back and left to right. Areas of uneven heat distribution will occur on an unlevelled unit. The charbroiler is equipped with adjustable legs. Turn the feet at the bottom of the legs to adjust to level. The unit should be rechecked for level anytime it has been moved.

VENTILATION HOOD

The broiler should be installed under a suitable ventilation hood. For safe operation and proper ventilation, keep the space between the charbroiler and vent hood free from any obstructions.

PROBLEM	POSSIBLE CAUSES
Uneven heating, sides burning	A. Burner valves improperly adjusted B. Fluctuating gas pressure C. Improperly adjusted burner
Too much top heat	A. Burner valves adjusted too high B. Faulty ventilation C. Overrated gas pressure D. Improperly adjusted burner
Uneven heat side to side	A. Burner valves improperly adjusted B. Appliance is not level side to side C. Improperly adjusted burner
Pilot outage	A. Pilot flame is set too low. Adjust pilot to allow for gas flow. B. Obstruction in pilot orifice C. Low gas pressure.
Yellow burner flames	A. Open burner shutters until flames are blue
Lifting burner flames	A. Close burner shutters until flames touch burner
Fluctuating gas pressure	A. Check for clogged vent on regulator

Product Specification Sheet

MODEL	STYLE(Manual)	Total Power input(kW) per Hour
ECB-16SX	Single Burner w/ individual control	7
ECB-24SX	2 Burners w/ individual control	14
ECB-36SX	3 Burners w/ individual control	21
ECB-48SX	4 Burners w/ individual control	28
ECB-60SX	5 Burners w/ individual control	35

WARRANTY

Cateryard warrants to the original purchaser of every new product, under normal and proper use and maintenance service as specified by Cateryard and upon proper installation and start-up in accordance with the instruction packet supplied with each unit. Cateryard's obligation under this warranty is limited to a period of one (1) year from the date of original installation.

WARRANTY CLAIMS

All claims for parts must be made directly through Cateryard. All claims should include:

Personal Details:

Your name:

Your company:

Address:

Email:

Phone:

Products Details:

Model number:

Serial number of the product:

Date of purchase:

Proof of purchase :

Pertinent information supporting the existence of the alleged defect.(Such as picture etc.)

Please send the above information to sales@cateryard.co.uk

Our warranty departments will according to the actual situation and reply you within 24hours.



Cateryard Limited

www.cateryard.co.uk