

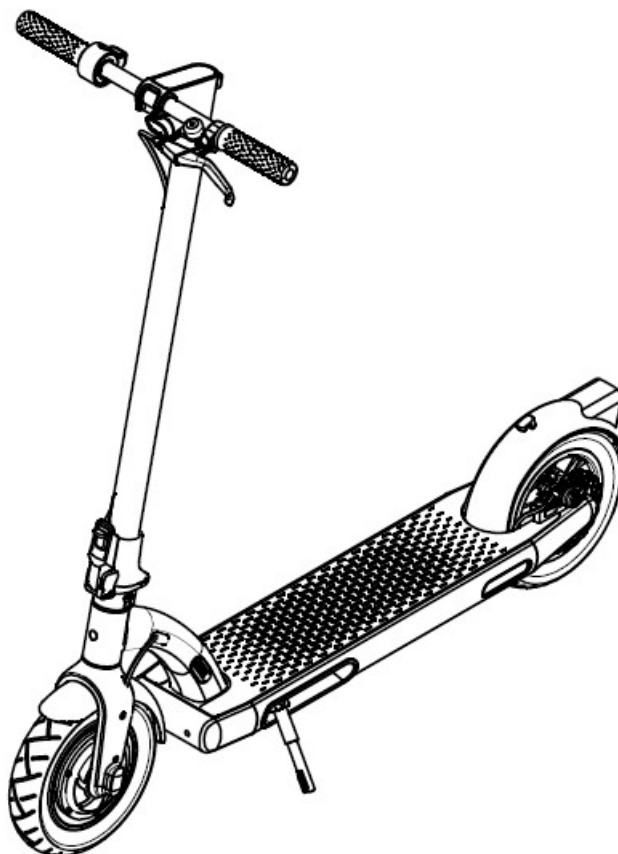

NAVEE N40 Electric Scooter User Manual

[Home](#) » [NAVEE](#) » NAVEE N40 Electric Scooter User Manual 

NAVEE Electric Scooter N40 User Manual



The pictures are for reference only. Please read the product manual before using the product
Warranty card included

Welcome

Thank you for choosing the NAVEE electric scooter N40 (hereinafter referred to as N40). Now you can experience the pleasure of riding your own electric scooter. It should be pointed out that the N40 is only a small-sized electric scooter intended for individual riding, it is not suitable for acrobatic use. Manufacturer: Zhejiang Feishen Vehicle

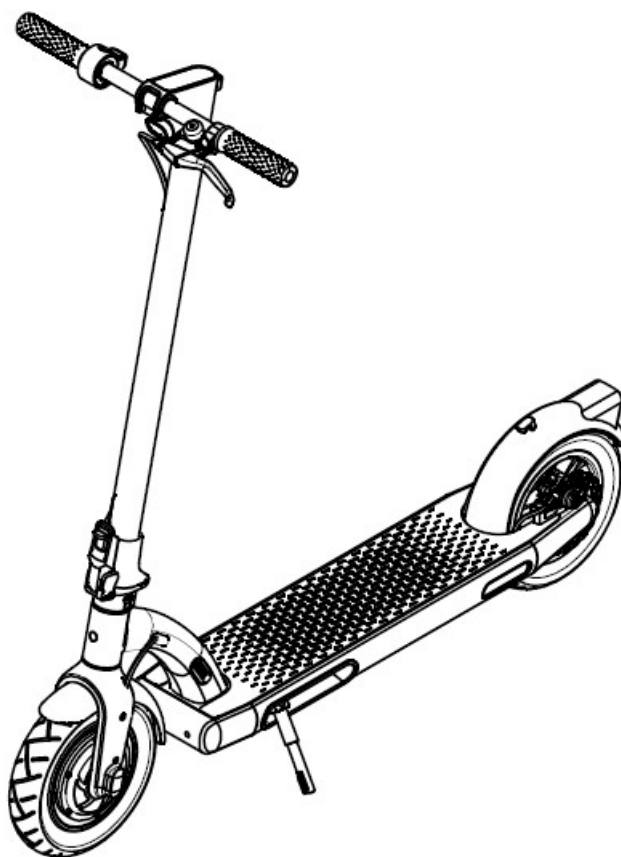

Contents

- [1 Products & Accessories](#)
- [2 Introduction to Functions](#)
- [3 Safety Instructions](#)
- [4 Product Illustration](#)
- [5 Correct Riding Method](#)
- [6 Handlebar Control](#)
- [7 Assembly](#)
- [8 Deployment Steps](#)
- [9 Folding Steps](#)
- [10 Charging](#)
- [11 Carrying](#)
- [12 Basic Operation](#)
- [13 Operating Instructions](#)
- [14 Riding Instructions](#)
- [15 Battery and Charger](#)
- [16 LED Display](#)
- [17 Maintenance](#)
- [18 FAQ](#)
- [19 SPECIFICATIONS](#)
- [20 Warranty and service](#)
- [21 Warranty card](#)
- [22 Documents / Resources](#)
- [23 Related Posts](#)

Scooter Body

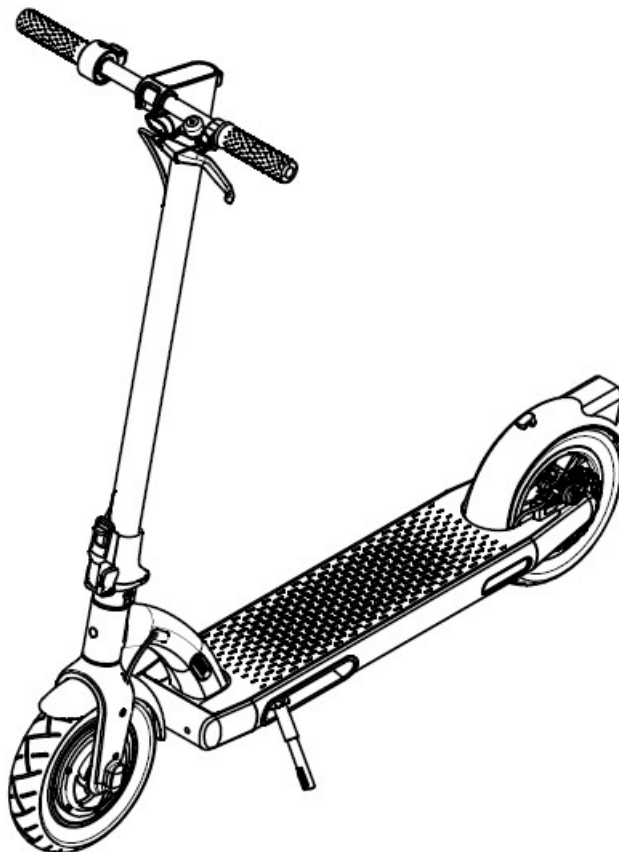

Accessories



Manual



Charger



M3 MS Wrench

Please check carefully to ensure the items in the packing box are complete and in good condition.



Warning! To prevent accidents, please place the packaging bags and product accessories in locations that are out of the reach of children.

Introduction to Functions

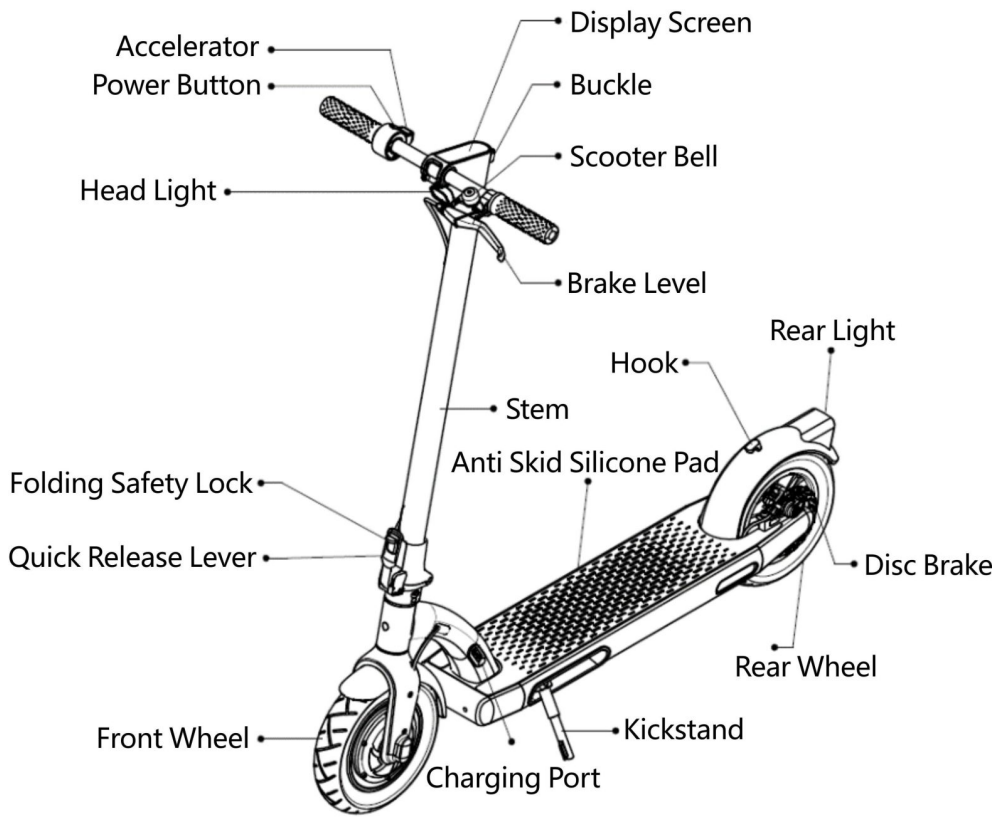

Safety Instructions

Note: before using the product, please carefully read and follow the following important safety information.

1. This product can only be used by one person. Do not carry others at the same time while you are riding. The product is recommended for use by riders over the age of 13 and under the age of 65. Other persons who are not suitable for riding this product include (1) persons under the influence of alcohol or drugs. (2) persons unable to engage in strenuous physical activities due to illness. (3) persons who are incapable of keeping their balance or who cannot keep their balance due to impaired motor skills. (4) persons whose weight exceeds the prescribed limit. (5) pregnant women (6) persons who suffer from visual and/or hearing impairment.

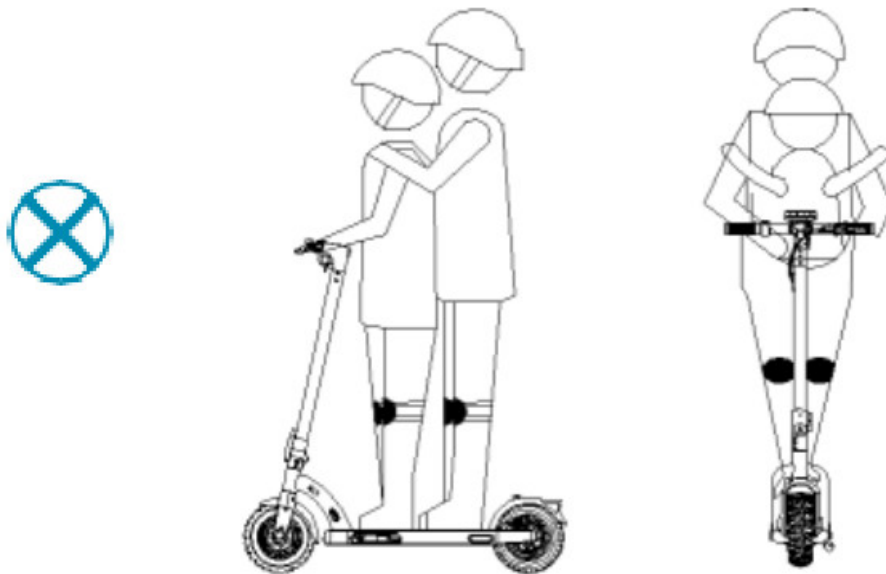

2. When riding this product, please wear a safety helmet and suitable protective devices. Do not ride barefoot or in high-heeled shoes.

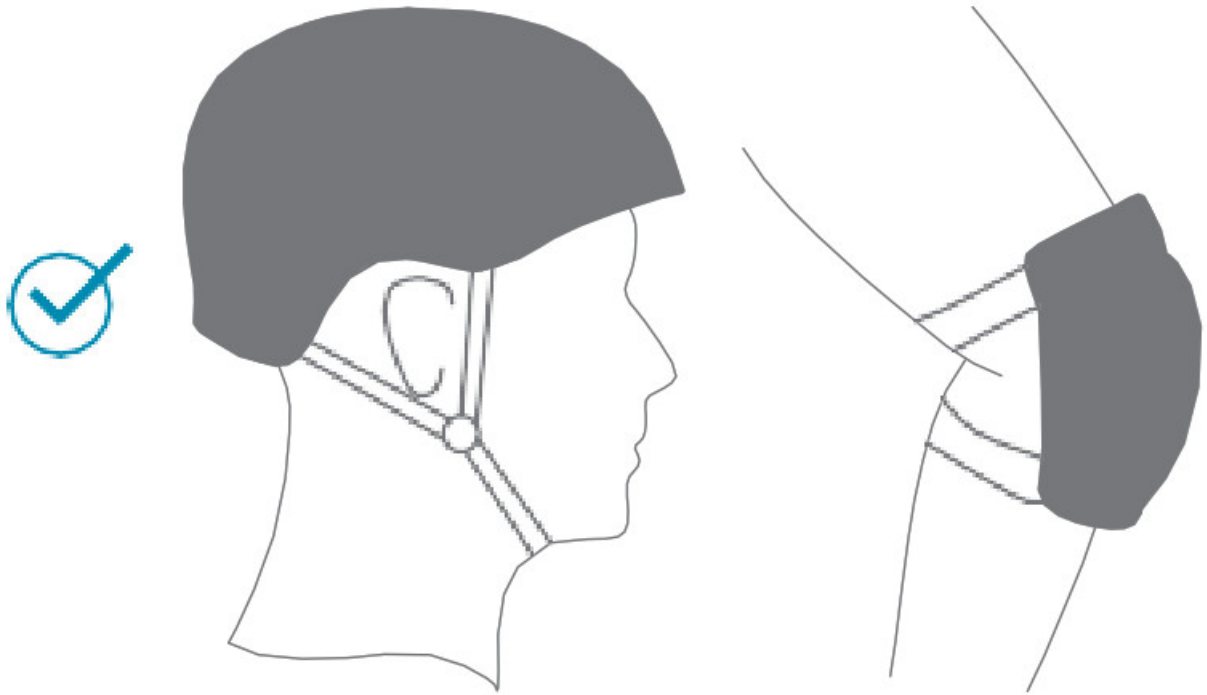

3. Do not ride this product in areas in which it is unsafe or illegal to ride, or on unsafe or off-limits roads.

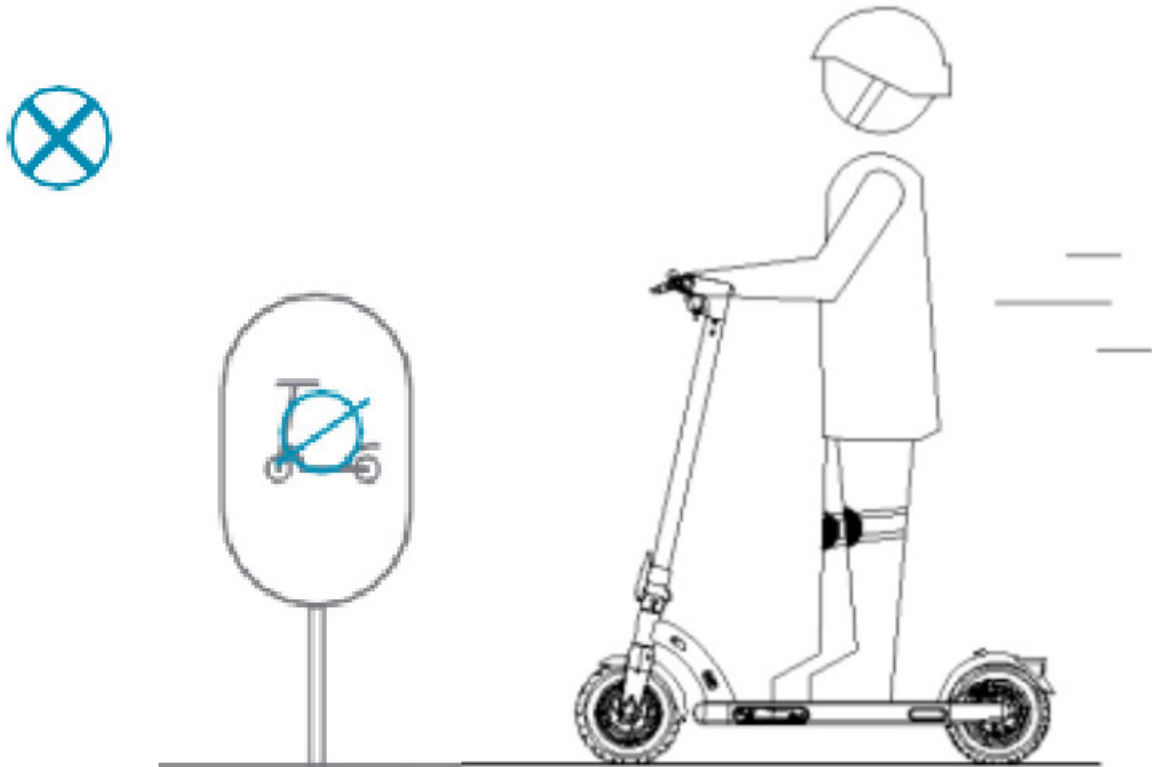

4. It is forbidden to ride this product on public roads and motorways.

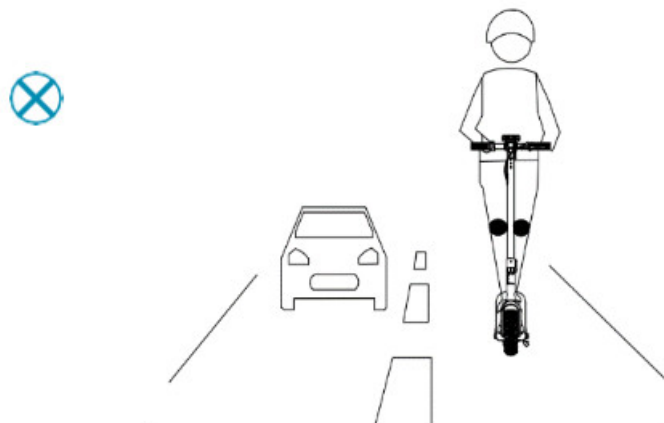

5. Do not engage in any dangerous actions during driving, such as riding with one leg or one hand. Make sure that both of your legs and hands are on the scooter.

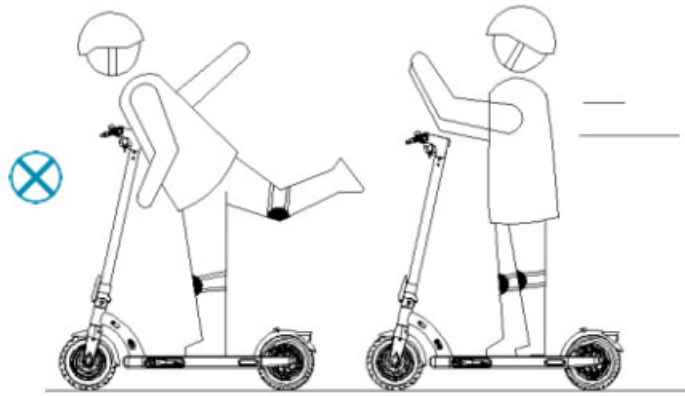

6. Do not attempt to ride over or pass steps, curbs or other obstacles that have a height of more than 3 cm, since doing so may cause the scooter to overturn and thereby cause personal injury to the driver or damage to the product, steps, curbs and/or other obstacles with a height under 3 cm should also be avoided as far as possible. Do not park the scooter on an incline.

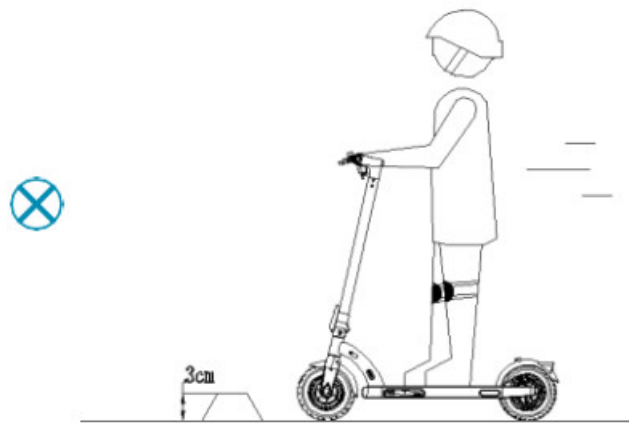

7. For your driving safety, please maintain a speed within 25 km/h while riding. Please try to avoid riding at night. If you are required to ride at night, please turn on the lights and maintain a speed within 15 km/h.



8. Do not use this product in an environment with a temperature below -10 °C.



9. In case of uneven road or other poor road conditions, please slow down in time and drive slowly and carefully or get off and push it. The scooter is a special riding product, please try to ride on a flat road without potholes.



10. Do not ride on the ground with oil or ice on the surface.

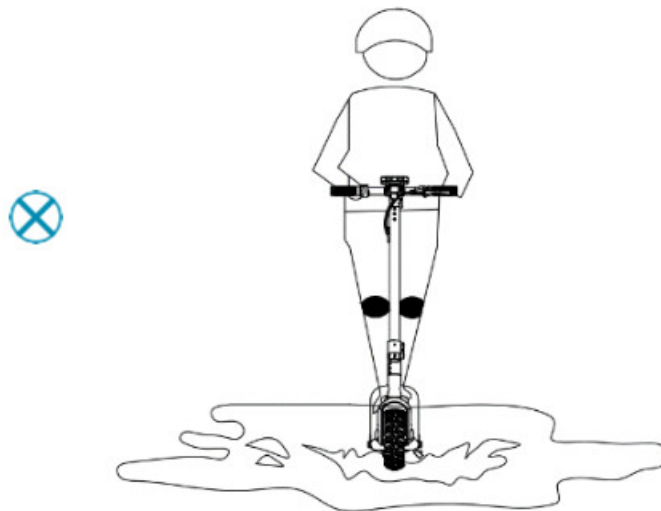

11. Do not immerse the product in water more than 4 cm deep to avoid damage to the battery of the scooter. 4 cm



12. Do not drive the scooter in snow or rain, on muddy, icy, or wet, roads under any circumstances do not drive the scooter over obstacles (sand, loose gravel, or roadblock). Doing so may result in loss of balance or grip. When riding in the rain, please keep your distance and avoid sudden braking.



Safety tips: do not hang or place any objects on its handlebars and body while riding.

13. Do not use this product beyond the maximum load(100 kg) specified in this product. 100 kg

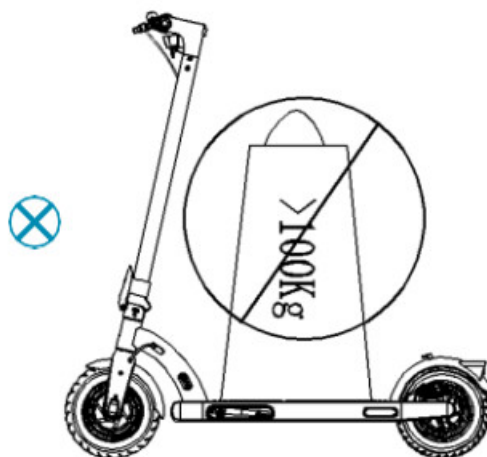

14. Please avoid using or placing the product in an environment where the temperature is above 40 °C or below-10 °C. Please do not place this product together with flammable items so as to avoid fire in unlikely accidental circumstances.

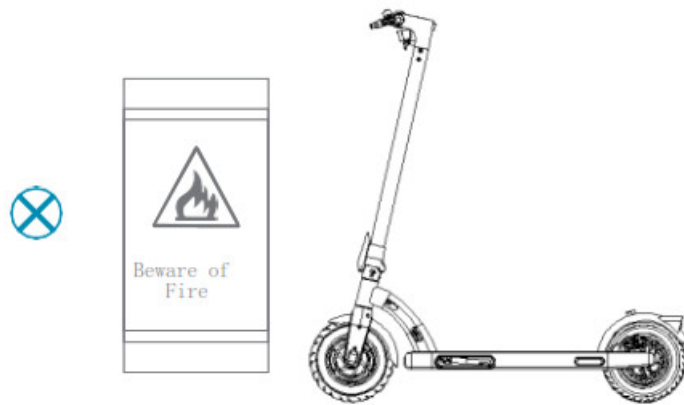

15. Users should ride safely and legally in strict accordance with local laws and regulations.

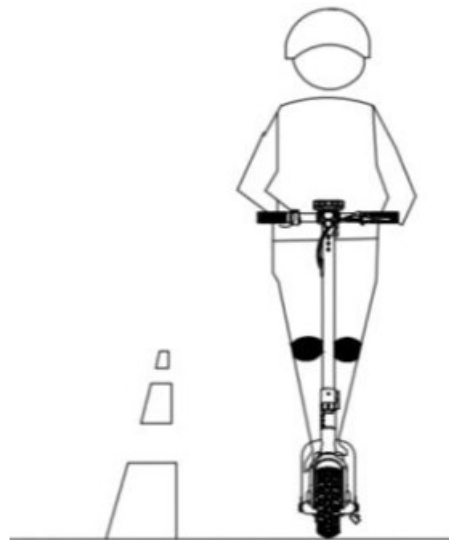

Product Illustration

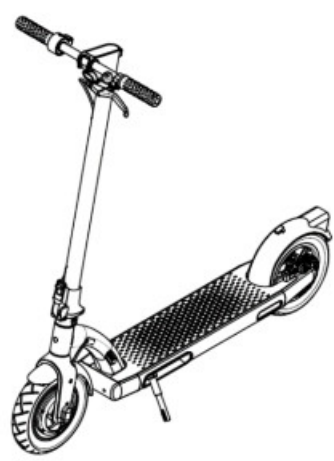

Open State

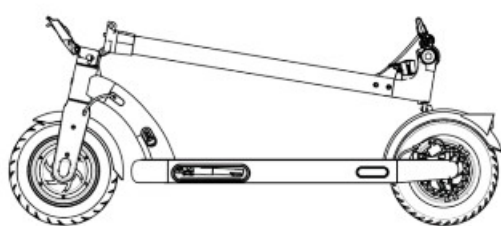

Folded State

Correct Riding Method

1. Check the scooter before each ride, and ride only after the folding safety lock is engaged.
2. Wear well-fitting flat-heeled sports shoes to ride this product.
3. Please practice riding in an open space.
4. Keep away from vehicles and crowded areas. Please drive on the roads or areas stipulated by local laws.
5. Safety helmets and protective equipment must be worn while riding.
6. The age of the rider should be between 13 and 65 years old (inclusive).
7. You should not drive on uneven ground. If there are any obstacles, please stop riding, fold up or walk across the blocked passage.
8. Avoid riding in rainy and snowy weather or at night, keep away from cars to avoid sudden braking.
9. The maximum load capacity of the product (user plus luggage) is 100 kg.
10. The height of the rider should be 1.4 m to 2.2 m (inclusive).
11. Do not hang or place objects on the scooter body and handlebars.
12. This product is a personal riding product and cannot be used for stunt riding.
13. Users should abide by local laws and regulations.
14. It is recommended that the front and rear lights are checked before each ride.
15. Do not modify or adapt this product.
16. Do not use replacement parts other than professionally produced parts provided by the original manufacturer.

Check the scooter before each ride, and ride only after the folding safety lock is engaged.

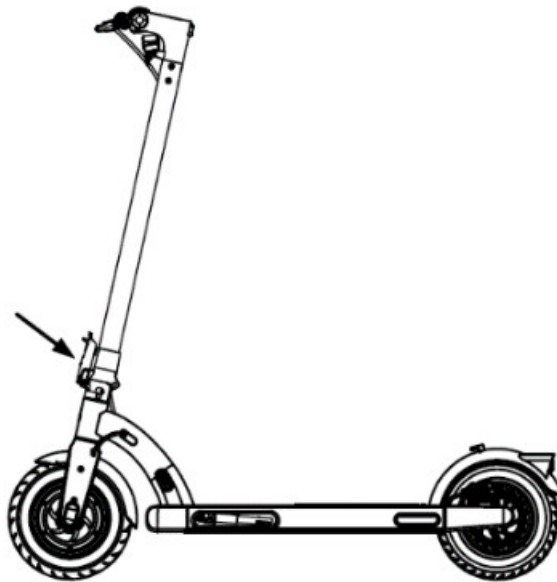

Do not use any replacement parts, not from the manufacturer or allow repair by other repairers than those approved by the manufacturer. You should understand that following the instructions and warnings in this manual can reduce risks, but not eliminate all risks. Please remember that you may be at risk of losing control, collision, and falling while using the scooter. When you enter a public area, please abide by the local laws and regulations. Just like all vehicles, the faster you drive a scooter, the longer it takes to stop. On the smooth ground, emergency braking may also cause the wheel to slip or the driver to fall. Therefore, it is very important to stay alert and keep a reasonable safe distance from other people and vehicles.

When driving into unfamiliar areas, keep alert and drive at low speed.

 **Warning!**

1. This product should be ridden on the roads and areas stipulated by local laws. It is forbidden to ride outside the roads and areas stipulated by the laws. It is forbidden to ride on motorways.
2. When crossing obstacles, stop riding and fold it or slow down to pass safely.
3. When passing pedestrians, please sound the bell to alert them.

Handlebar Control

1. Hold the handlebar with both hands, not with one hand.
2. Turn in the right direction, hold the handlebar tightly and turn left and right.
3. Do not rotate the handlebar 360°.
4. The brake lever and the bell are on the left side of the handlebar.
5. Hold the brake level with your left hand.
6. The power & speed control buttons are on the right side of the handlebar.
7. When riding, press the accelerator with your right thumb.
8. Please ring the scooter's bell when you are in a crowded place.
9. Do not add a basket to the front of the scooter.

Warning!

1. When riding, please do not hang heavy objects on the body and handlebars, this will affect the stability of the scooter and cause potential safety hazards.
2. Regularly check whether the screw part of the handlebar is tight and whether the frame, fork, brake, and other parts can be used normally. If scooter parts are damaged, please stop using and repair or replace the parts promptly.

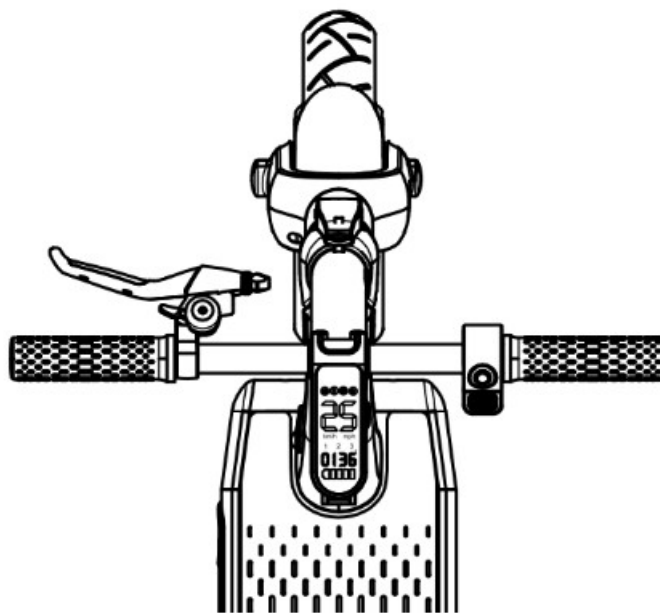

Assembly

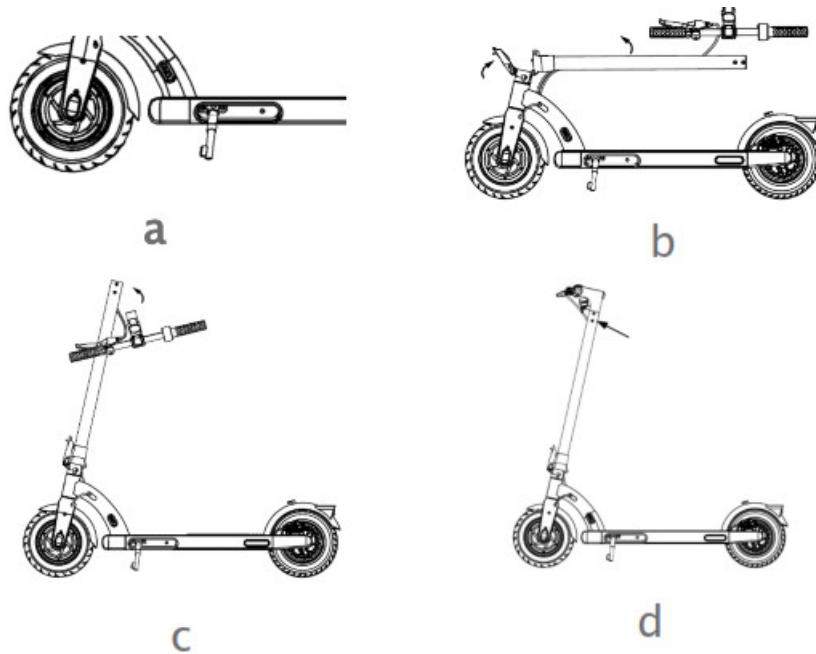

a. Open the kickstand.

b. Hold the stem up until it is completely in an upright position. Lift the folding safety lock, and push the quick-release lever inward to the end.

c. Install the handlebar onto the stem, and make sure to install the handlebar in the correct direction.

d. Pre-tighten the six screws with the included wrench. Make sure the handlebar is correctly installed and then tighten the screws thoroughly. Safety tips: before each ride, please check to ensure that the screw, folding safety lock, and other link parts are not loose.

Deployment Steps

a. Open the kickstand.

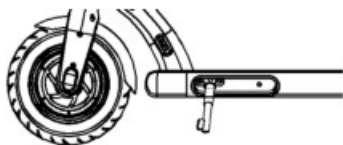

b. Pull the buckle upwards to release it from the hook.

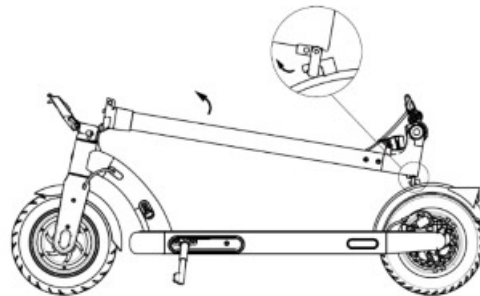

c. Hold the stem back up, lift the folding safety lock, and push the quick-release lever inward to the end.



Safety tips: when lifting the front part of the N40 scooter, do not put your hand between the joints.

Folding Steps

The scooter needs to be turned off before being folded. Since the product can be folded, do not step on or turn the folding safety lock when riding.

1. Open the kickstand.



2. Hold the stem, lift the folding safety lock, and open the quick-release lever, then fold the stem.



3. Align the buckle with the hook and secure them together.

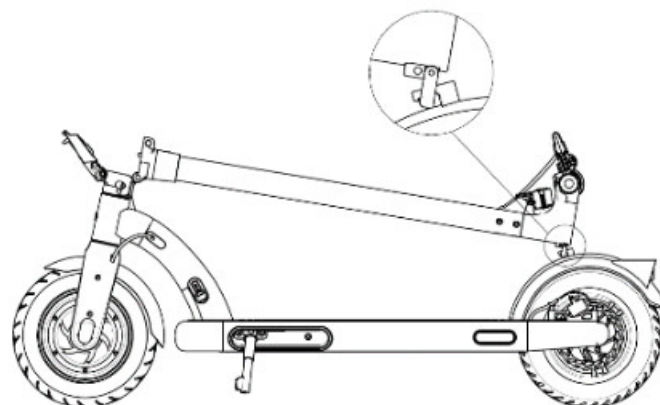

4. Fold up the kickstand to complete folding.

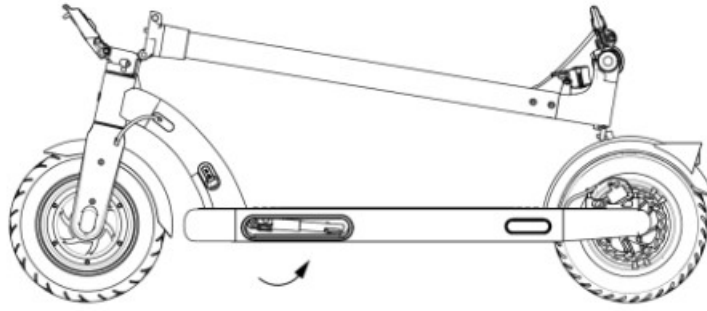

Charging

Note: Please always use the original charger.



1. Open the rubber plug of the charging port.



2. Plug the charger into the charging port.

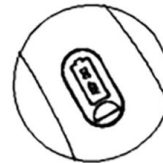

3. Close the rubber plug after charging.

1. Open the rubber plug of the charging port.
2. Plug the charger into the charging port.
3. The scooter is fully charged when the LED on the charger changes from red (charging) to green (trickle charge).

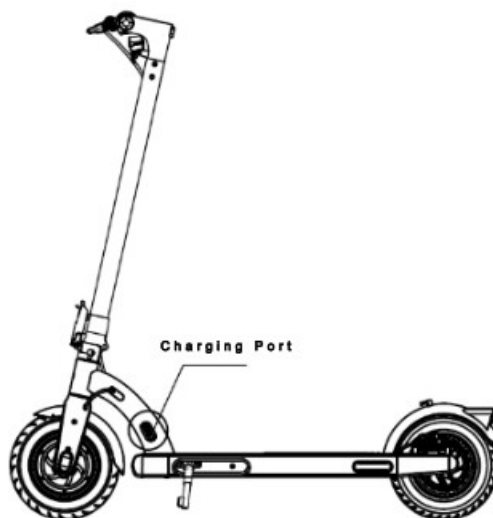

Warning!

1. Do not touch the interface when charging, be careful of electric shock.
2. Please check whether the power is off before charging.
3. Do not turn on the power when charging.
4. Do not use this product when charging to avoid damage.

5. It is recommended to charge at 0-45.

6. Please keep the scooter body away from the heat source, open fire, flammable and explosive gas(liquid).

Carrying

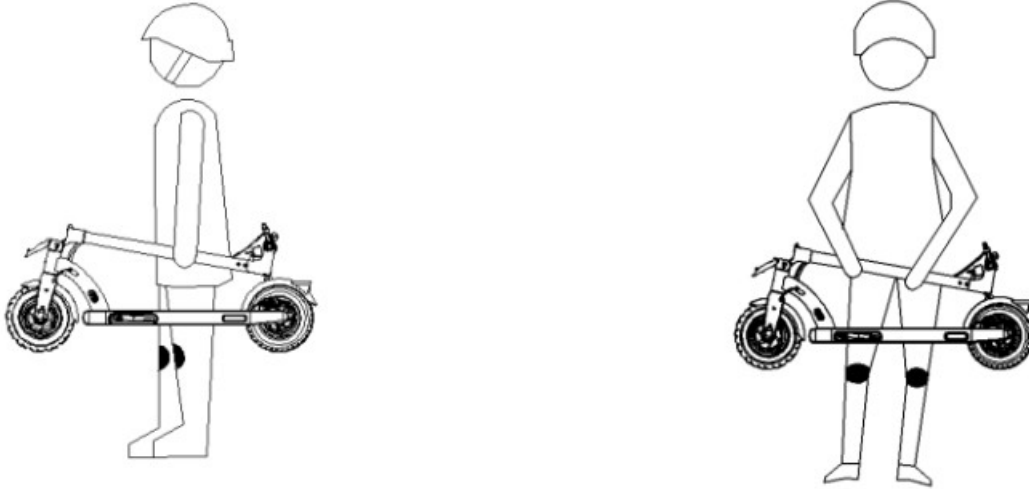

Hold the stem with either one hand or both hands to carry.

Basic Operation

A: Accelerator

B: Power & Gear Shift Button

D: LED Display

E: Bell

F: Brake Level

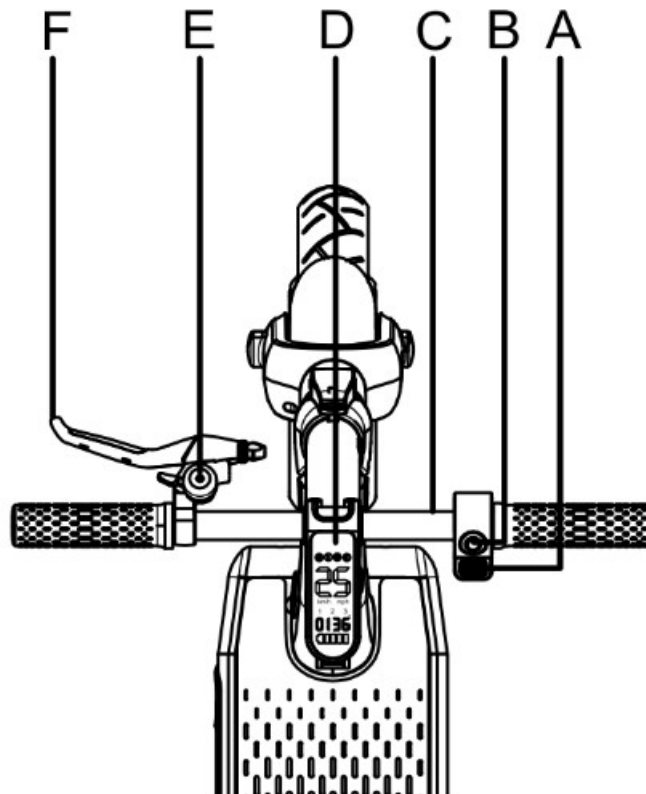

Operating Instructions

Power Button

Power On/Off: Press and hold the power button for 3 seconds to turn on the scooter.

After power on, press the power button for 3 seconds to turn it off.

Gear setting

After power on, press the power button twice to shift the gears.

Speed Control

Press the accelerator to control the speed range(1-15.5mph(25 km/h)).

Brake Control

Hold the brake control on the left to the brake. The greater the holding force is, the greater the braking force is. When braking quickly, it is easy to fall due to the loss of traction, and you are at risk of serious injury. Please drive at moderate speed and pay attention to potential dangers.

Head and Tail Light

After power on, click the power button to turn the head and tail light on and off.

Emergency Braking

In case of emergency, hold the left brake tightly to control the brake, which can activate the rear wheel friction brake and the front wheel electromagnetic brake at the same time. In order to avoid riding risk and damage to the rear wheel, the rear emergency brake should not be used during normal driving within the speed control range.

Tire Pressure

Before riding, please make sure that the tire pressure is not lower than 230KPA and the maximum pressure is not higher than 250 KPA. If the tire pressure is too high, there is a risk that the tire will burst. If the tire pressure is too low, the mileage will be reduced and the tire will be damaged. If the scooter is not used for a long time, the tire pressure may also be lower than the standard. (Note: the solid tire is not in the scope of requirements).

Riding Instructions

Start Riding

1. Press the power button to turn the scooter on.
2. Place one foot on the deck and the other foot on the ground.
3. Slide the scooter body forward and gently press the accelerator the scooter will move forward slowly.
4. When riding, hold the handlebar tightly with both hands to avoid injury or falls due to losing balance.
5. When the scooter is running smoothly, move the other foot onto the pedal. Press the accelerator, the greater the acceleration angle, the faster the scooter speed.

Riding Preparation

1. Choose an open space suitable for riding.
2. Ride on the flat road.
3. Unfold the product according to the instructions and wear protective equipment.
4. Wear comfortable shoes that fit your feet well.
5. Keep away from vehicles and crowded places.
6. Protect yourself and others under any circumstances.

Parking

1. Under normal circumstances, if you hold the left brake handle, the scooter will power off and brake immediately. The greater the grip angle, the greater the braking force.
2. In case of emergency, hold the left brake lever tightly to activate the front wheel electromagnetic braking and rear-wheel friction braking. The rear brake disc will heat up rapidly in use. Please do not touch it.

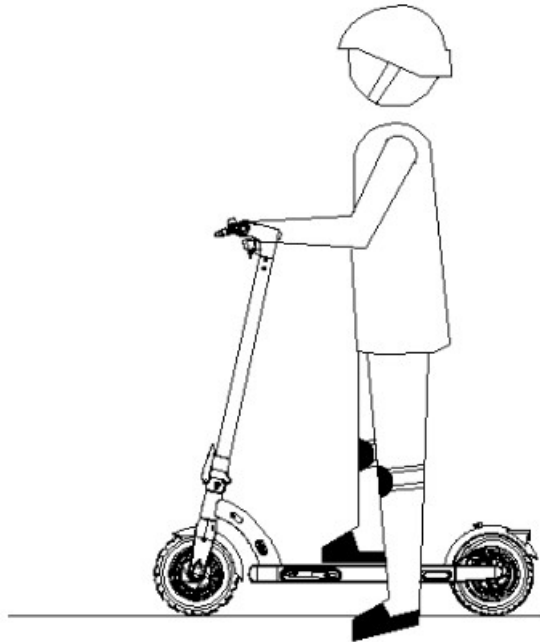

Note: In order to ride safely, NAVEE scooter N65 is equipped with a non-zero start, and the scooter with a non-zero start can only use the accelerator function after sliding forward for a certain distance.

Battery and Charger

Each NAVEE scooter N40 is equipped with a bespoke lithium battery and a dedicated smart charger. Each scooter and its accessories have a specific number, do not use other brands of chargers, other types of chargers are not suitable for this product.

Battery

Ex-factory voltage is 39~41 VDC, rated voltage is 37 V DC, the maximum charging voltage is 42VDC, and the rated capacity is 10 AH. The Lithium battery provided by our company can be recharged at least 500 times, and normal battery capacity can reach more than 70%.

Charger

The special charger provided has overcharge protection. When the battery is fully charged, the charger will automatically power off. Full charge time is 7-8 hours. Battery damage caused by water immersion, collision, and other abnormal use factors is not within the scope of warranty policy. If the charging port or charging line is wet, please do not connect the charger.

Kinetic Energy Recovery

During driving, pressing the brake will activate the kinetic energy recovery system. This will convert some of the kinetic energy into electrical energy that is stored and used. The kinetic energy recovery system can also enhance emergency braking. At the same time, the recovered kinetic energy can help to increase the endurance with changes in the power display.

Safety tips: do not remove the external lithium battery while charging.

LED Display

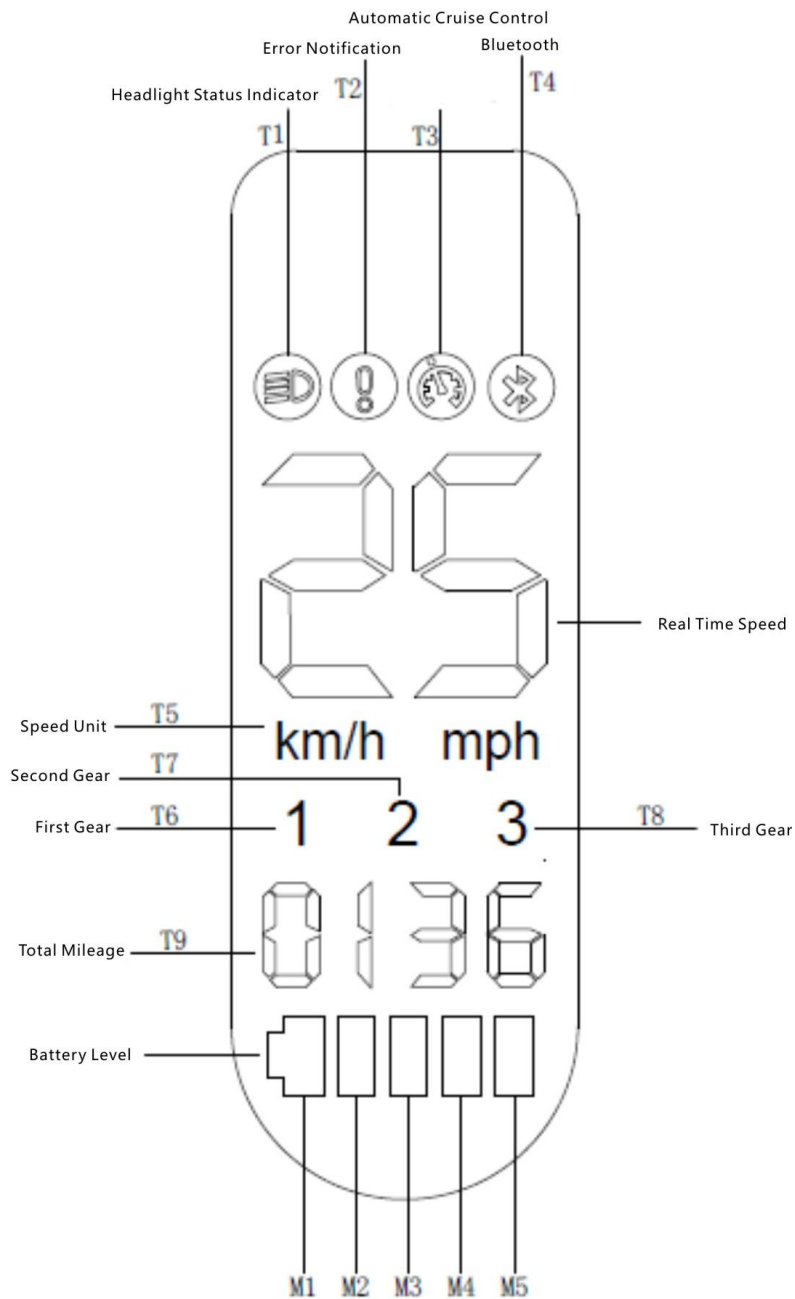

Power Indicator Definition of LED

The battery power is indicated by 5 bars, each representing approximately 20% of a full battery. The M5 LED flashes when the battery level falls below 10%.

80%	60%	40%	20%	<10%
M1-M5 On	M2-M5 On	M3-M5 On	M4-M5 On	M5flashing

Headlight State Indicator:

On	Off
If the headlight setting is on, the indicator will always be on.	If the headlight setting is off, the indicator will always be off.
T1 On	T1 Off

Gear Indicator:

First Gear	Second Gear	Third Gear
First Gear engaged	Second Gear engaged	Third Gear engaged
T6On T7/T8 Off	T7On T6/T8 Off	T8On T6/T7 Off

Power Button:

Press and hold the button for 3 seconds to turn the scooter on/off. When the scooter is on, press the button to turn on/off the headlight, and press twice to cycle through the modes.

Warning T2 flashes and the display values E1-E6 flash

Fault	Code	Solution	
Rx communication failure	E1	Please check whether the braking tail light is on. If it is not this means that there is no power to the controller. Replace the controller or instrument. If it is on, please check whether the connecting line from the instrument to the controller is open.	
Braking Error	E2	Please check if the brake is pressed	If it is pressed, release the brake.
			The connecting wire between the braking and the instrument needs to be checked on whether there is a short drain or open circuit. 1. Open circuit or short circuit need to replace the connecting wire .Replace the brake hand. 2
Handle Error	E3	Please check if the handle is pressed	If it is pressed, release the handle
			If not, please check the connecting wire between the handle and the instrument for short circuit or open circuit
Wheel Motor Error	E4	Check whether the wheel motor and the controller cord are well connected.	If not, connect the wheel motor to the controller cord.
Controller Error	E5	If the controller is damaged, replace the controller.	
Overheating Warning	E6	Check whether the battery temperature is too high?	Once the battery temperature is within the normal operating temperature range, the scooter can be used or charged again.

Note: Regularly check the tightness of bolted parts, especially the fastenings of the axle, folding system, steering system, and brake shaft.

Maintenance

Lubrication

During maintenance, add a small amount of grease or lubricant to the folding part every 6 months, check the tightness of the screw of the scooter every 3 months, and tighten the screw if loose.

Battery

When you first get the electric scooter, please fully charge the battery before use. Charging will not damage the battery. If this product is not used for a long time, please make sure it is charged at least every 3 months.

Storage and daily maintenance

The scooter needs to be turned off before being cleaned.

Please do not leave the scooter in the hot sun or very wet place for a long time.

Please keep the scooter clean.

Do not clean the scooter with a high-pressure hose.

Please do not scrub with corrosive detergent.

Do not make any modification

Please do not refit or modify the scooter in any way, including the steering column and sleeve, rod, folding parts, and rear brake assembly.



Warning!

1. It is recommended to check the folding device, shock absorber, wheel, and axle of the scooter regularly. If there is wear, please replace them promptly.
2. It is recommended that the frame and front fork are regularly checked. Long-term use may lead to screw loosening. Clean and tighten the screws regularly.
3. Please replace the parts in case of failure.
4. When the parts exceed the expected service life, please replace them in time.

FAQ

When the product fails, please refer to the following ways to try for a solution:

1. The display screen is black.
Reason: this scooter is exposed to sunlamp for a long time.
Solution: put the scooter in a cool place for a period of time.
2. The value is inconsistent with the actual value.
Reason: incorrect or missing parameter setting.
Solution: long-press the power button to turn off and then press to restart the scooter.
3. The digital display is dim.
Reason: poor battery contact or no battery power.
Solution: turn off the power, and then turn it on again. If the fault still exists after the battery is charged, please contact the manufacturer or dealer.
4. If the product cannot operate normally, please check whether the following have been completed.
 - a. Check that the power is on.
 - b. Check the battery level on the display.
 - c. Check whether the left brake lever and rear disc brake are in place.
 - d. Check that all sockets and connections are properly connected. If all steps have been completed and the

product still does not work properly, please contact the manufacturer or dealer.

5. The controller is damaged. Do not replace the controller without authorization.

Please contact the manufacturer or dealer, do not disassemble the product without authorization.

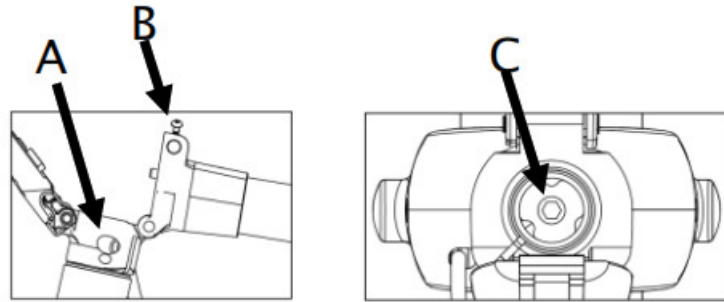

6. The stem is getting unstable

Reason: the screw at the joint of the stem and the folding seat is loose.

Solution: lower the column, loosen the three screws, raise the column, tighten the screws at the back of the pole, and then lower the pole and tighten the three loosened screws to solve the problem.

SPECIFICATIONS

Parameter	Name	FN-E1
Size	Vehicle: L x W x H	1135 X500X1178mm
	After Folding: L x W x H	1135X500X475mm
Weight	Net Weight	About 16 kg
State	Max. Load	1000
Main Parameter	Max. Speed	15.5 mph (25 km/h)
	General Range	About 40 km (It depends on the environment, angle, speed, driving habits, etc.)
	Max. Climbing Angle	About 1 2%
	Suitable Surfaces	The road surface should be flat and smooth, the road surface bulge should be le.-than 2 cm, and the depression should be l ess than 3 cm
	Tire	10-inch pneumatic rite
	Shock Mitigation Sys tem	Pneumatic Tires
	Noise test	Less than 70 dB
	IP Rating	IpX4
	Brake System	Rear-wheel disc braking+front wheel (motor) electromagnetic brake.braking distance<Brake system 7m
	LED Display	Real-time speed. mileage, gear, braking force. voltage display, speed unit, headlight status indicator. Bluetooth, automatic cruise control, fault display
	Lamp System	LED front and rear! amps
	Motor Power	350W
Charging Parameters	Adapter	54.6 V/2 A/Short Circuit Protection
	Lithium Battery	37 VDC, 10 AH
	Charging Time	About 7-8 h

Warranty and service

Warranty Statement:

If the product is within the warranty period from the date of your purchase, we will repair, replace or return it free of charge as the case may be if it is confirmed by the manufacturer or dealer that it is faulty or damaged due to quality defects under normal use. Unless otherwise specified by relevant laws, the product or component used for replacement may not be new, but nevertheless performs well and is equivalent, at least, to the original product or component in function. The warranty period is calculated from the first date of purchase of the product, subject to the invoice date. If there is no valid invoice, the warranty period shall be calculated from the date of delivery plus thirty (30) days. If the invoice date is later than the actual delivery date of the product, the warranty period shall be calculated from the actual delivery date. The repaired or replaced products shall continue to enjoy the warranty for the rest of the warranty period, but not less than thirty (30) days. For warranty application, please contact the manufacturer or distributor of the product and follow the instructions. When applying for a warranty, an accurate, complete and clear valid sales invoice should be provided.

The above warranty does not apply to failure, malfunction or damage caused by: (a) misuse, abuse or improper transportation, maintenance or storage, such as but not limited to use, storage or maintenance under improper temperature, humidity or other improper environmental conditions; (b) force majeure or accidents, network or power interruption and other reasons beyond our reasonable control; (c) repair or removal without authorization from the manufacturer; (d) the way in which damage has been caused by any third party products or services shall be specified purposes other than those for which the product has been designated or intended: (f) using the product in violation of the product instructions: (g) using the product for commercial purposes; or (h) the accumulated mileage recorded by the scooter body has exceeded 2000 km. Normal wear and tear or aging, scratches, abrasions, and problems caused by the use of coatings, solvents or other chemicals during the general use of the product do not fall within the scope of the warranty. If the original identification label of the product is changed or damaged, this warranty will be invalid. The integrity and completeness of the products and of the attached materials are not within the scope of the warranty.. You should inspect the products on the spot when receiving them and object immediately to any ascertained discrepancy/ies.

The above warranty statement applies to our products. This warranty grants specific legal rights and other rights you may have according to the law. Nothing in this document affects your rights in a fashion that is not susceptible to exclusion or restriction in accordance with the law.

Warranty information for the product:

Type	Warranty content	Warranty period
Controller	Controller assembly and central warehouse dashboard	12 months
Lithium battery	Lithium battery pack and protection board	12 months
Main body	Frame assembly, hub motor, front body, rear hub, brake assembly, folding assembly, vertical bar, front fork, rear fork, vertical bar rotating parts, control bus, braking line	12 months
Enclosure	Charger. brake handle. thumb accelerator	6 months

Reminder: The following consumables delivered with the scooter upon purchase are not covered by the warranty: inner and outer tires, front lamp assembly, instrument cover, handle cover, fender, rear tail lamp, decorative cover, foot support, charging port seat, rubber plug and scooter kit. When repairing and replacing parts, do not use any replacement parts other than professional parts provided by the original manufacturer. For replacement, please contact the manufacturer.

Warranty card

When purchasing the product, we recommend that you clearly fill in the following information and affix the sales seal to protect your legitimate rights and interests:

User's information	Full name		E-mail	
	Mailing address			
	Contact number		Postal Code	
Product information	Name of the product		Sales date	
	Product model		Invoice number	
Vendor information	Name		Contact number	
	Address		Postal Code	
<p>Note: (1) This form shall be confirmed by the seller's seal (2) For products applicable to relevant "three guarantees" regulations, this warranty card is equivalent to "three guarantees certificate": (3) The maintenance record is subject to the voucher issued by the authorized service organization. Please keep it in a safe place after applying for service.</p>				

Warning!

This product is the same as any mechanical part. The scooter can bear high stress and wear. Various materials and components scooter's machinery, axle) may react differently to wear or fatigue. If the component has reached the expected service life, it may break suddenly, causing the risk of injury. If any problem is found, please repair and replace the parts in time. If there are cracks, scratches, and discoloration in the area under high load, it indicates that the component has exceeded its service life. Please contact the manufacturer or dealer to replace the component as soon as possible.

FCC Statement

This device complies with part 15 of the FCC rules. Operation is subject to the following two conditions: (1) this device may not cause harmful interference, and (2) this device must accept any interference received, including interference that may cause undesired operation.

Changes or modifications not expressly approved by the party responsible for compliance could void the user's authority to operate the equipment.

NOTE: This equipment has been tested and found to comply with the limits for a Class B digital device, pursuant to part 15 of the FCC Rules. These limits are designed to provide reasonable protection against harmful interference in a residential installation. This equipment generates uses and can radiate radio frequency energy and, if not installed and used in accordance with the instructions, may cause harmful interference to radio communications. However, there is no guarantee that interference will not occur in a particular installation. If this equipment does cause harmful interference to radio or television reception, which can be determined by turning the equipment off and on, the user is encouraged to try to correct the interference by one or more of the following measures:

- Reorient or relocate the receiving antenna.
- Increase the separation between the equipment and receiver.
- Connect the equipment into an outlet on a circuit different from that to which the receiver is connected.
- Consult the dealer or an experienced radio/TV technician for help.

The device has been evaluated to meet general RF exposure requirements. The device can be used in portable exposure conditions without restriction.

Documents / Resources



[NAVEE N40 Electric Scooter](#) [pdf] User Manual

NAVEEN40, 2A4GZ-NAVEEN40, 2A4GZNAVEEN40, N40 Electric Scooter, Electric Scooter

[Manuals+.home](#)

[privacy](#)