

**DUALTRON**  
***MINI SPECIAL***  
Personal Mobility  
**PRODUCT MANUAL**

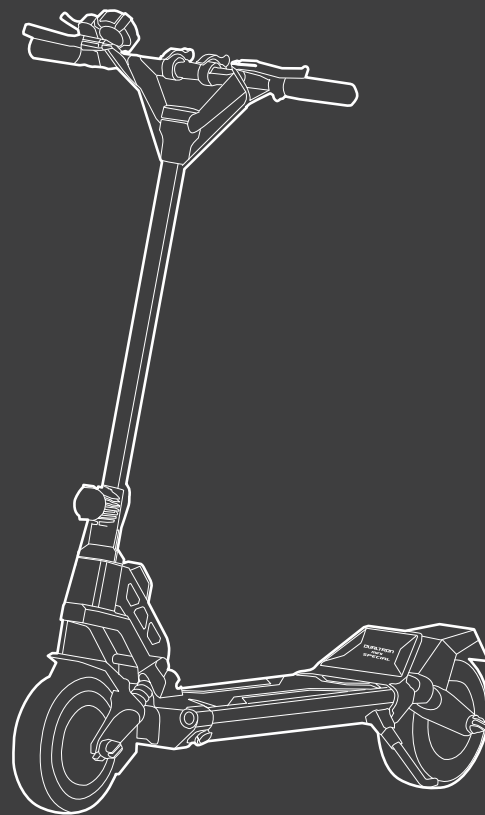



Scan the QR code to download the latest user materials  
and obtain the latest updates and safety instructions.

# DUALTRON

The dream of electric technology.

The pictures shown are for illustration purposes only. Actual product may vary.

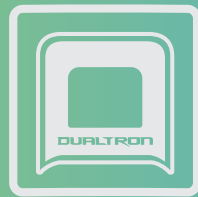





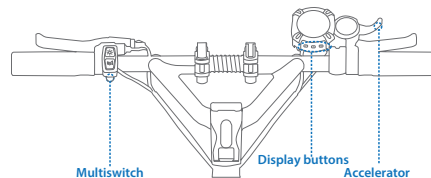
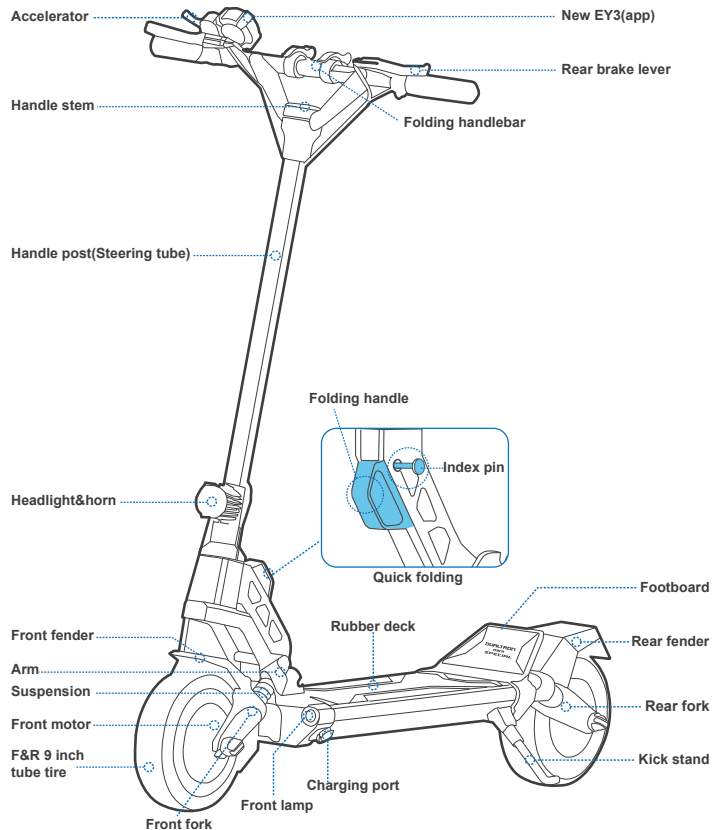

*MINIMOTORS*



## Diagram And Functions



Name	Function	Operation method
 Headlight Button	Turn on/off headlight	Press the light button, turn on/off the headlight.
 Horn Button	Turn on the horn	Press the Horn Button, the scooter will beep once.
 Accelerator	Speed up	Pull the throttle to accelerate.
 Power Button	Turn on/off power	1. Press and hold the Power button to turn on/off the scooter. 2. Press the button to adjust the speed gear.
 Set Button	Settings	1. Press and hold the Set button to enter/exit ECO mode. 2. Press the button to switch battery voltage/percent indication
 Mode Button	Mode selection	1. Press and hold the Mode button to enter/exit the mode setting, and automatically return to the main interface after 30s. 2. Press the the Mode button to switch ODO/time indication. (Time defaults)



## Specifications

	Item	Parameter
<b>Product</b>	Model	Dualtron Mini Special Long Body(Single motor)   Dualtron Mini Special Long Body(Dual motor)
<b>Battery</b>	Battery Capacity	52V10Ah / 52V13Ah / 52V17.5Ah / 52V21Ah LG   52V12Ah / 52V15.6Ah / 52V21Ah LG
	Range	35km / 46km / 60km / 65km   40km / 50km / 65km
	Charging Ambient Temperature	0 to 40°C (Battery temperature exceeds 55°C,BMS start protection program.)
	Battery Management System	Over-heating, short circuit, over-current, over-discharge and over-charge protection
<b>Rider</b>	Max. load	120kg
	Recommended Age	14–60 years old
<b>Display</b>	Type	New EY3 display(DUALTRON APP available)
<b>Motor</b>	Motor Type	BLDC Hub Motor
	Nominal Power	900W   900W*2
<b>Machine</b>	Net Weight	Around 23kg   Around 27kg
	Max. Slope	Around 27%(15°Single-wheel drive)   Around 37%(25°Two-wheel drive)
	Drive System	Single motor drive   Dual motor drive
	Speed	25km/h
	Length × Width × Height	1180x620x1250mm
	Folded: Length × Width × Height	1270x270x390mm
	Wheelbase	Approx.950mm
	Ground Clearance	Approx.120mm
	Traversable Terrain	Asphalt/flat pavement; obstacles < 5 cm; gaps < 5 cm
	Operating Temperature	-5 to 45°C
Storage Temperature	-20 to 50°C	



## Specifications

<b>Brake</b>	Type	Dual drum brake
	Electric Brake	ABS&EBS (Indicating the battery temperature exceeds 55°C,BMS start protection program,ABS/EBS fails.)
<b>Charger</b>	Input Voltage	100-120V/200-240V~
	Max. Output Voltage	58.1V2A
<b>Tire</b>	Type	9 inch tube tire
	Tire Pressure	50 psi
	Material	Rubber
<b>Suspension</b>	Type	Front&rear spring and rubber suspension

\*Disclaimer: this is not a legal opinion or legal advice. The information provided herein (including in the App) is for your convenience and information purpose only. It is not intended to cover every piece of law and/or regulation that may be applicable to this product. DUALTRON explicitly hereby disclaims any and all warranty and/or representation, express or implied, related to completeness, accuracy, up-to-date of such information. DUALTRON reserves the right but not obligation to correct, implement and/or update the information. You shall use the information at your own risk. It is your sole responsibility to learn and understand any and all the law and/or regulation, requirements, prohibition, restriction and/or limitation imposed by either law, government authority, court, private party or the others that may apply to your use of this product.

\*Theoretical Range: tested while riding with a full battery, 75 kg load, 25°C, at the speed of 25 km/h on average on pavement.

\*Typical Range: tested while riding with a full battery, 75 kg load, 25°C, at the speed of 50 km/h on average on pavement. (Some of the factors that affect range include speed, number of starts and stops, ambient temperature, etc. )

\*Max.Speed: tested while riding with a full battery,75kg load,25°C,straight road on flat road with no wind. (Some environmental factors can affect max speed,uneven roads, crooked roads, temperature, wind, etc.)



## Packing List

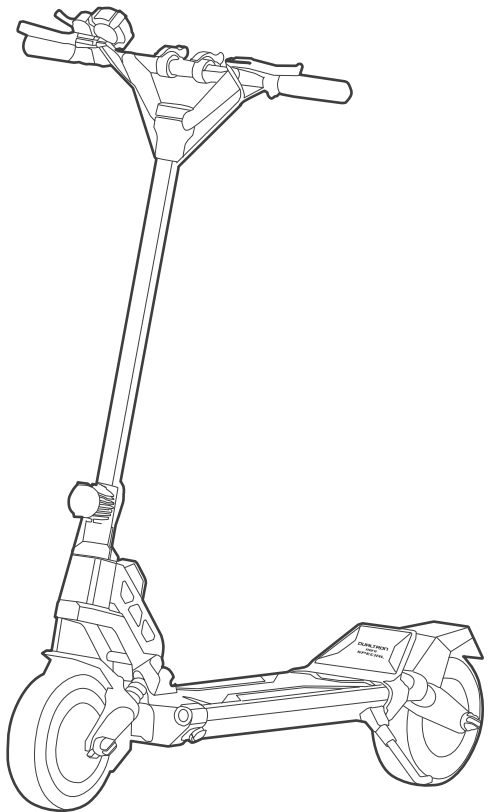

### Accessories



Charger x1

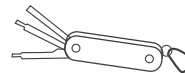

Multitool x 1



Manual



Screw Cap x 2

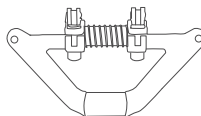

Folding Handlebar Body



## Assembly

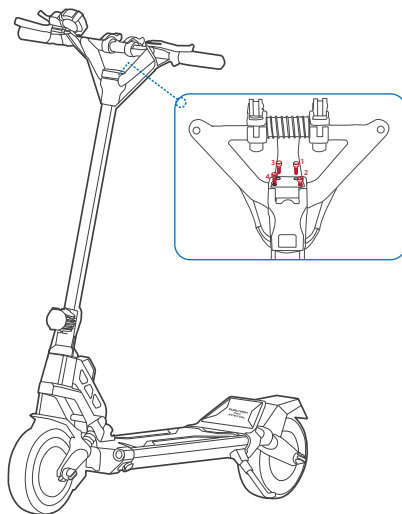

① Loosen the 4 screws from handle stem, attach the folding handlebar body, and tighten the 4 screws back again. (When tightening the screw, the first step screw is 90% tight, you must tighten it diagonally, according to the order 1-4-2-3; the second step all screws are 100% tightened.)

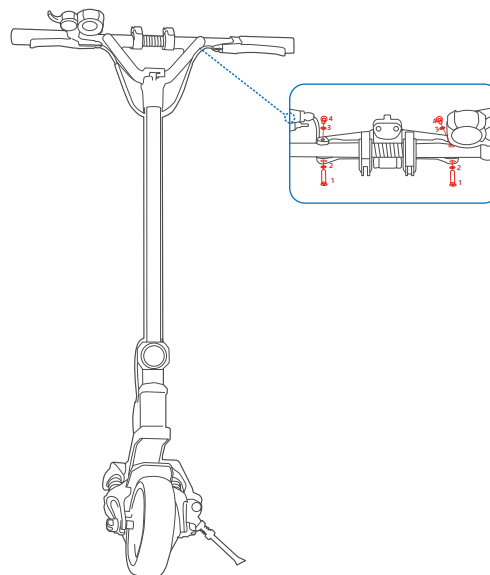

② Attach the handle to the folding handlebar body after loosening the screws on the handle, and fix the handle with same screws. (Make sure not missing any small gaskets and screws.)





## Bluetooth Connection

### APP Download Guide

#### Method 1

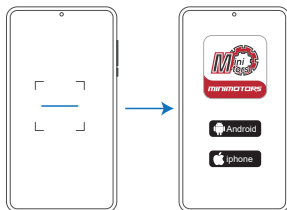

1. Scan the QR code to download the APP.
2. Choose the mobile phone system that suits you to install, and register / log in.

#### Method 2



1. Search "DUALTRON" in the application and download it, and register / log in.

### Pair the Bluetooth on the APP

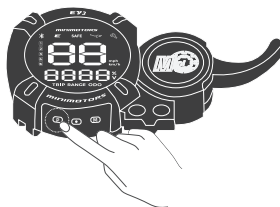

Power on the scooter.

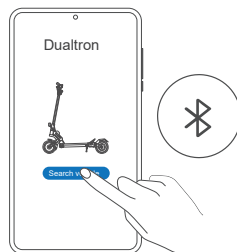

Click "Search vehicle" and pair with your scooter. \* The scooter is connected to the Dualtron app when the Bluetooth symbol lights up.

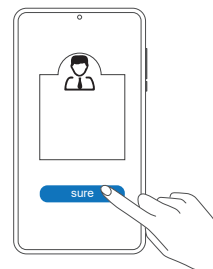

Select "bind as owner".  
(No one else can connect, only people authorized by you are allowed to connect. Authorizations are created on the app.)



## How to Ride

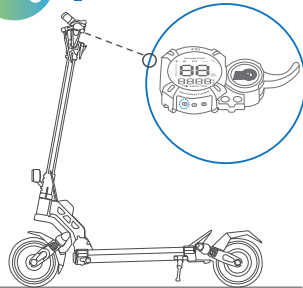

1. Power on the scooter and choose the speed mode. \* Please choose the speed mode before riding! Note: Speed mode can be choose via the Dualtron app.

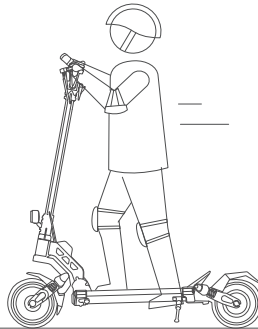

2. Stand on the footboard with one foot and push off with the other foot to start gliding. \*Make sure you have disabled SAFE mode. (SAFE mode setting via Dualtron app. Deactivate safe mode by squeezing brake lever.)

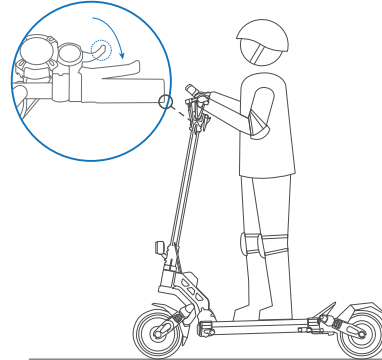

3. Put both feet on the footboard and stand stably. Pull the accelerator to speed up.

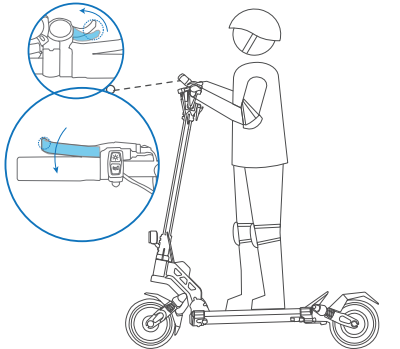

4. Slow down by releasing the accelerator and squeezing brake levers.

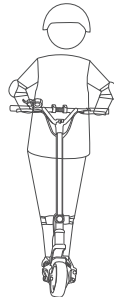

5. To turn, shift your body and turn the handlebar slightly. \* Please watch out for road conditions, sufficient turning space is required.

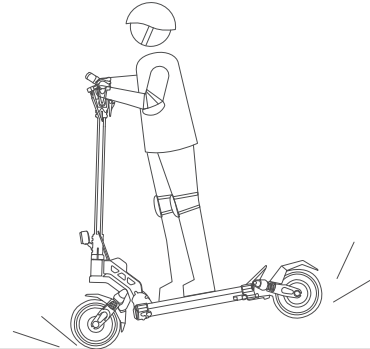

When hard braking, serious danger or injury may occur. Maintain a moderate speed and look out for potential hazards.



## Folding

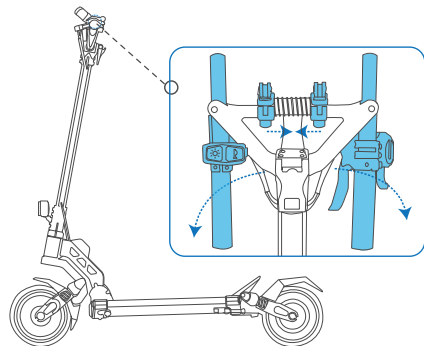

Release the QR lever of handlebar, move the locking slide inward and fold the handles.

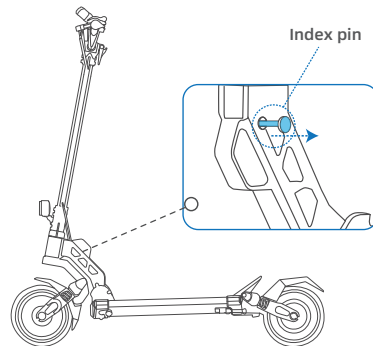

Pull the index pin outward, then turn it a little, the index pin will get stuck and the folding handle will work.

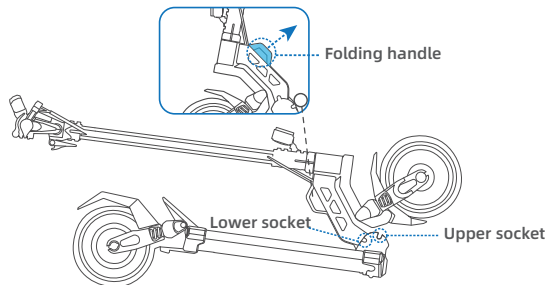

Pull the folding handle, folding plunger will come out of the upper socket and slip to lower socket.

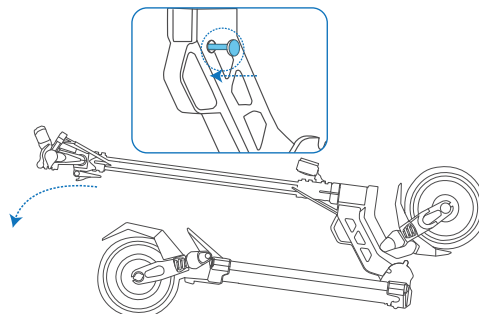

When the folding plunger gets stuck in lower socket and the folding handle resets in the stem headset, please remember to insert the index pin back to fix the folding system.

