

APOLLO PHANTOM

INTRODUCTION

Hello World

Thank you for purchasing the Apollo Phantom™. The electric scooter industry is still young and it takes forward-thinking customers like yourself to advance it. We hope you enjoy your new scooter as much as we loved developing it.

How to get help?

We're here to help regardless of the problem you are facing. You can get in touch with us in the following ways:

HELP CENTER:

support.fluidfreeride.com

EMAIL:

support@fluidfreeride.com

Warning

Incorrect assembly, maintenance, or use of your Apollo scooter can cause component or performance failure, loss of control, serious injury, or death. Even if you're an experienced scooter rider, you must read and understand the entire manual and any documentation provided for subcomponents or accessories before riding. If you are not sure you have the experience, skills, and tools to correctly perform all assembly steps in the manual and the assembly video at support@fluidfreeride.com, consult our support team or a local electric scooter shop.

Contents

Introduction	2
Assembly & Set Up.	4
Operation	10
Settings.	18
Battery Info	20
General Safety	22
Maintenance	24
Troubleshooting.	28
FAQs	30
Warranty & Support	32

ASSEMBLY & SET UP

WARNING:

Incorrect assembly, maintenance, or use of your Apollo scooter can cause component or performance failure, loss of control, serious injury, or death. Even if you're an experienced scooter rider, you must read and understand the entire manual and any documentation provided for subcomponents or accessories before riding. If you are not sure you have the experience, skills, and tools to correctly perform all assembly steps in the manual and the assembly video at apolloscooters.zendesk.com, consult our support team or a local electric scooter shop.

Intro

Setting up your scooter right is the single most important step to your safety.

Please note that this process is also available in video format through our help centre. Visit support@fluidfreeride.com to view it.

We recommend having the following items ready prior to starting the setup process:

- Box cutters or knife
- Stool or bench
- Air pump
- Strong friend

Unbox your scooter

Open the box using the box cutter and fold open the top. Inside you should see protective styrofoam along with the following contents:

- Apollo Phantom electric scooter
- Manual
- Charger and cable
- Toolkit

If any of these items are missing, please contact us immediately.

With the help of your friend, remove the scooter from the box and place it on a flat surface. We recommend using a stool or bench as the wheels need to be able to spin freely. Carefully remove the protective material from the scooter and set it aside. We suggest keeping both the styrofoam and the box in case you need to ship your scooter back to us. Otherwise recycle the materials wherever possible.

Prepare for assembly

Unfolding

1 The first step is to unfold your Apollo Phantom. To do so, ensure the hook is not clipped into the rear pedal. If it is, push down on the stem and unhook it from the rear pedal.

2 Locate the safety pin inserted into the folding mechanism and gently remove it. This will allow the stem of the scooter to be lifted in the following step.

3 Open the stem of the scooter by lifting it up towards the front wheel. Ensure you do so until the stem reaches its maximum position.

4 Locate the folding latch and bring it up, locking the stem. The latch will require some force to lock fully upright.

5 Place the safety pin back in the designated location, ensuring it is pushed all the way in. This acts as an additional safety mechanism, keeping the stem locked in place.

6 Lastly, make sure the latch is secured with the safety ring. Locate it to the side of the folding latch and slide it right. This safety mechanism prevents the latch from unlocking due to vibration or shock.

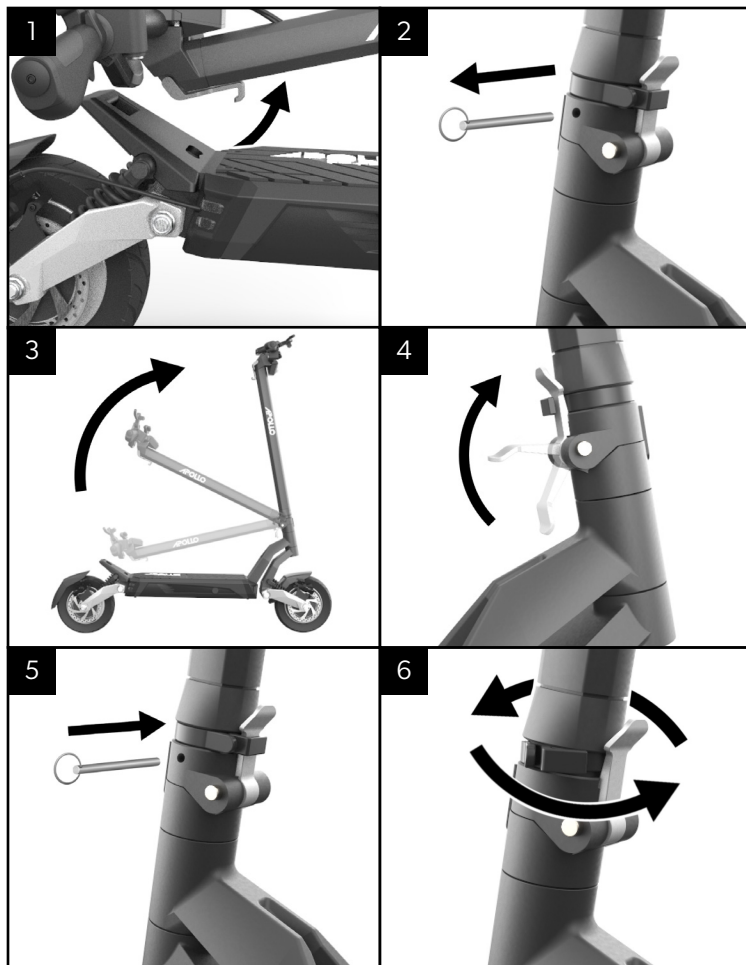

Attach handlebar

1 Locate the headlight at the top of the stem, and identify two screws holding it attached to the handlebar clamp. Using the included allen key, gently unscrew the two screws.

2 Once completed, you will see the light fixture come off from the clamp, revealing a total of four screws on the handlebar clamp. These four screws hold the handlebar inside of the clamp. Proceed to unscrew all four of these screws until the front half of the clamp comes off.

3 Go ahead and grab the handlebar, placing it inside the clamp. Make sure to position it correctly - the throttle should be on the right. If you have another person near you, now may be a good time to ask for their help holding the handlebar still.

4 Then pick up the allen key with one of the screws, and gently start turning clockwise. Next, pick up another screw and go in the diagonal hole from the first screw. This way you will create enough pressure between the two screws to hold the handlebar still.

5 Once you notice the handlebar is becoming more fixed in place, stop tightening the screws. Take a moment to adjust the handlebar - ensure it is centred and the handles are at a comfortable angle. If all looks good, grab the remaining two screws and continue to tighten the clamp until you can no longer turn the screws.

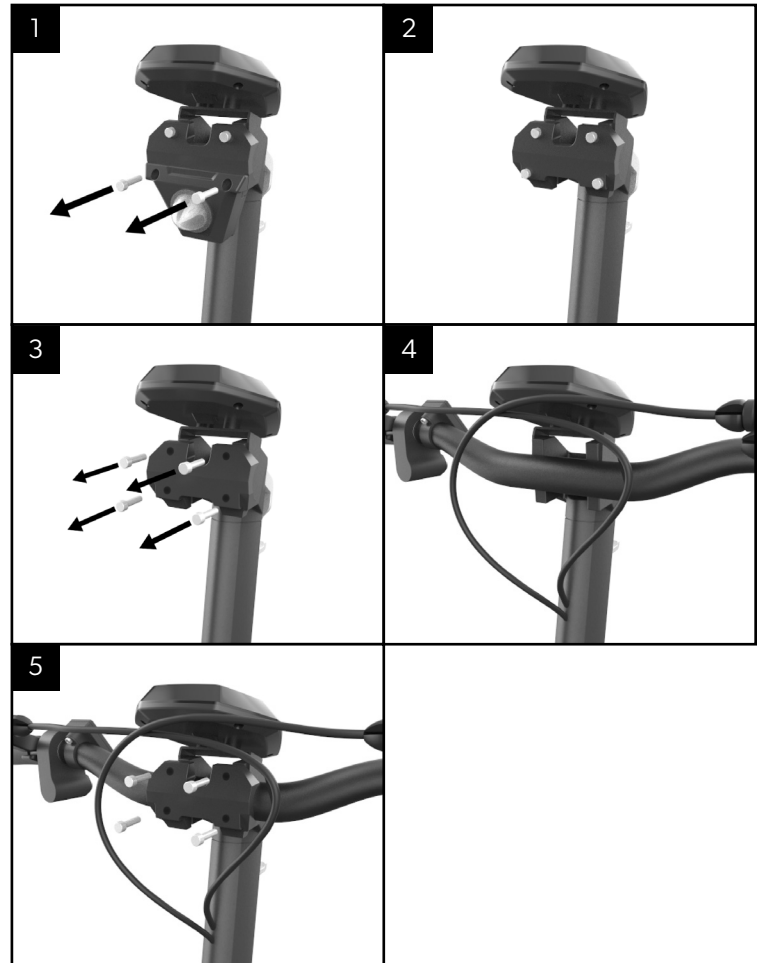

Attach command centre

The various latches and buttons on your handlebar might come loose. We ship them this way on purpose - should there be any impact to the carton, the components will shuffle as opposed to break. That said, let's get them tightened now!

1 Grab the included toolkit and locate the left button panel. Twist the button panel until it reaches a comfortable angle. Keep in mind that once on a scooter, you will be higher up than you are now, while setting up the scooter. For that reason, we suggest placing the button panel further up.

2 When ready, open allen key size X and locate the screw in the rear of the button panel. Tighten it until it reaches its final position.

3 Next, repeat the process with the turn signal button panel. Once again, angle it until

you reach a comfortable position, then locate the rear screw and tighten it until final position has been reached.

4 Last but not least, let's take care of the left brake handle. Find a comfortable angle, then locate the screw underneath the handle and tighten it using allen key size X.

5 Next, let's move on to the right side of the handlebar. Locate the throttle panel and angle it until it reaches a comfortable position. Then grab the toolkit, and once again tighten the adjustment screw in the rear of the throttle panel.

6 Lastly, let's move on to the right brake handle. As before, angle it until a comfortable position is reached and proceed to tighten the screw in the rear until maximum position is reached. You should be all set!

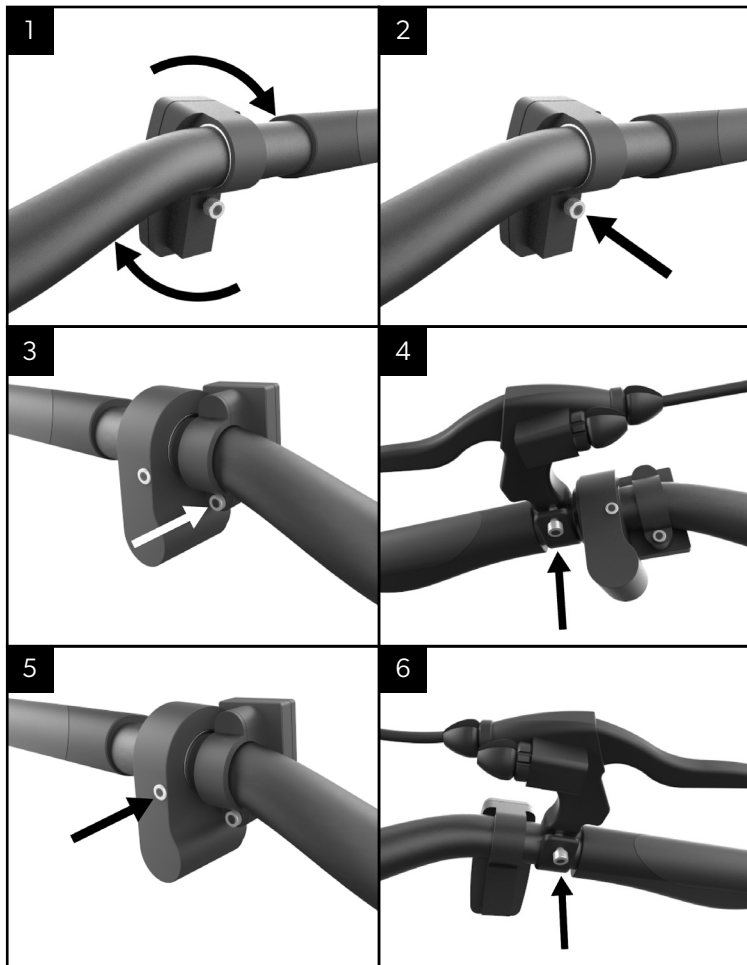

Perform test

1 Locate key attached to the brake line and insert it into the key ignition. Turn clockwise to power on the scooter. Locate the power button on the left side of the handlebar and press it for 3 seconds to power on the scooter.

You should now be able to see the display powered on. Keep the scooter elevated on the stool or bench, as the testing will involve spinning both wheels. If you notice one of the motors not spinning, please contact us immediately. You may notice either motor emitting a noise at low speeds, or perhaps even moving backwards for a split second before rolling forward. This is perfectly normal. The motor is communicating with the controller and identifying its position as well as which direction to roll in. This is perfectly standard

and does not pose any risk of damage to the scooter.

2 Begin by pressing the throttle. You should notice both wheels start to accelerate. Continue to accelerate for 5 seconds, then release the throttle and slam both brakes at the same time. Slamming the brakes adjusts the position of your brake callipers when used for the first time. If you notice the brakes emitting repeating sounds, it is likely the rubbing of brake pads, which will disappear after a few weeks of riding. To clarify, rubbing brake pads are not a defect - they are a consequence of our choice to set up the brakes on the tighter side. This allows for more effective braking, and the rubbing sound does disappear within a few weeks of usage.

3 Next, press the light button and confirm all four lights (headlight, two front deck lights, and one rear tail light) are powered on. If all of the lights do not power on, please contact us immediately.

4 Next, grab an air pump and locate the air valve on the front tire. Remove the safety cap and attach the pump tube to the tire valve. Turn on the air pump and read the PSI measure - the ideal tire pressure for the Phantom is 50PSI. Inflate or deflate the tire as needed until the pressure is 50PSI. Repeat the step with the rear tire.

For charging instructions, please refer to the "Operation" section on page 10.

Congratulations, you have successfully set up your new Apollo Phantom. If you experience difficulties with the setup at any step, please refer to our support centre for a video walkthrough of the process. Alternatively, you can contact our support team at support@fluidfreeride.com for assistance.

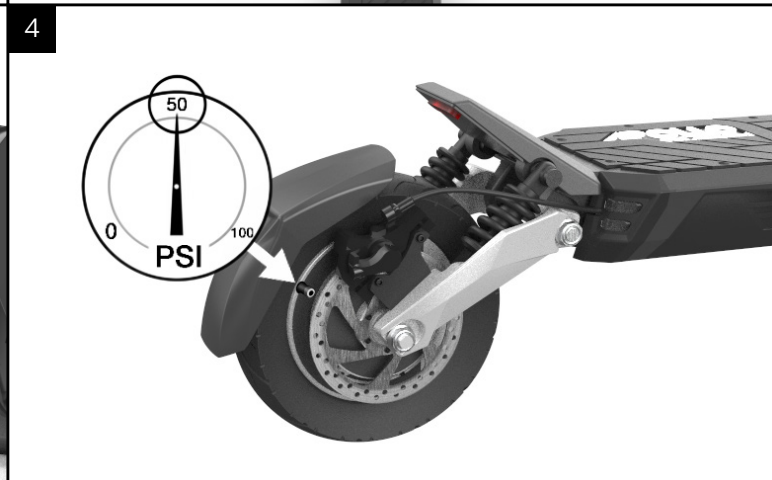
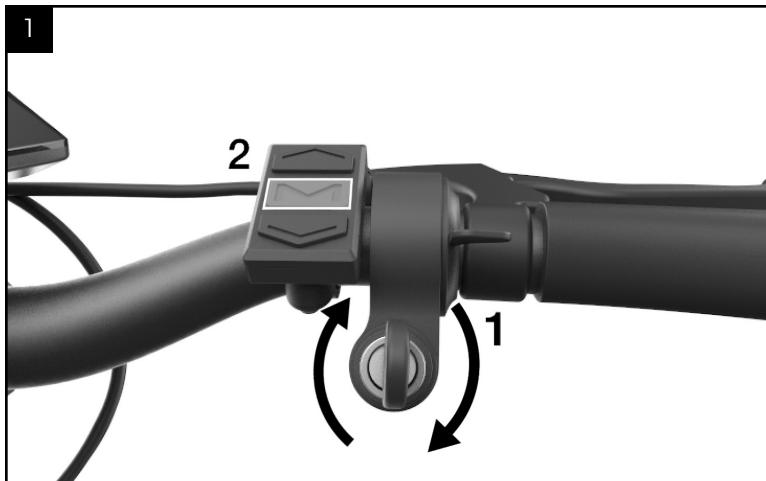

OPERATION

WARNING:

Incorrect assembly, maintenance, or use of your Apollo scooter can cause component or performance failure, loss of control, serious injury, or death. Even if you're an experienced scooter rider, you must read and understand the entire manual and any documentation provided for subcomponents or accessories before riding. If you are not sure you have the experience, skills, and tools to correctly perform all assembly steps in the manual and the assembly video at apolloscooters.zendesk.com, consult our support team or a local electric scooter shop.

Charging

This section focuses on how to charge your scooter correctly. For information about battery health and best practices, please review the Battery Information section on page 20.

The battery pack comes with a built-in battery management system. This includes overcharging protection amongst other features, allowing your scooter to stay plugged in, even after it is fully charged. Please note that this applies to short periods of overcharging, such as the scooter being plugged in overnight. Please do not leave the scooter plugged in and charging for extended periods of time as it may result in battery damage or fire.

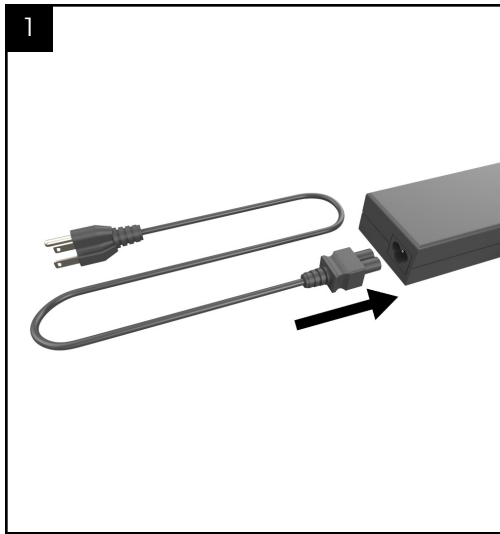

1
First, ensure the two parts of the charger are connected securely. The wall AC plug should be connected to the charger box. The connection between the cable and box should feel firm with no wobble or play.

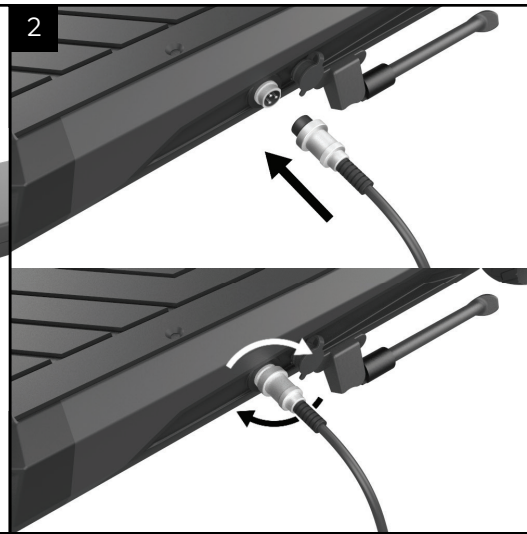

2
Next, locate the three pin connector on one end of the charger. Open the charging port cap on your scooter and identify the position of the pin holes. Align three pin connector with the pin holes, and gently insert the cable. When it reaches its maximum position, secure it by turning the safety ring clockwise. The three pin connector should now be safely connected to the scooter's charging port.

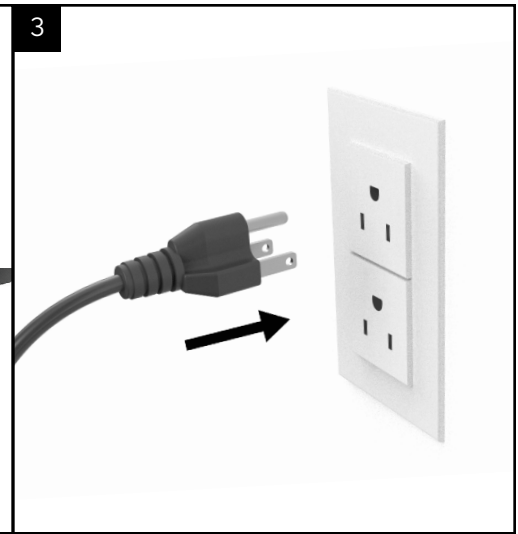

3
Proceed to plug the AC plug on the other end of the charger into a wall power outlet. If the battery is 100% full, the charger light will turn green. If it is anything less than 100% full or simply put - charging, the charger light will be red.

Folding

- 1** Begin by locating the safety ring and turn it clock-wise to unlock the folding lever.
- 2** Identify the safety pin and gently pull it out to release the safety mechanism.
- 3** Grab the folding latch, and pull it down to fold the stem. Make sure to keep one hand on the stem at all times as it will drop down instantly after the folding latch is released.

- 4** Fold the stem all they way down until it reaches its final position.
- 5** Place the safety pin back in the designated location, ensuring it is pushed all the way in.
- 6** Attach the hook located on the stem to the gap in the base of the scooter to secure it.

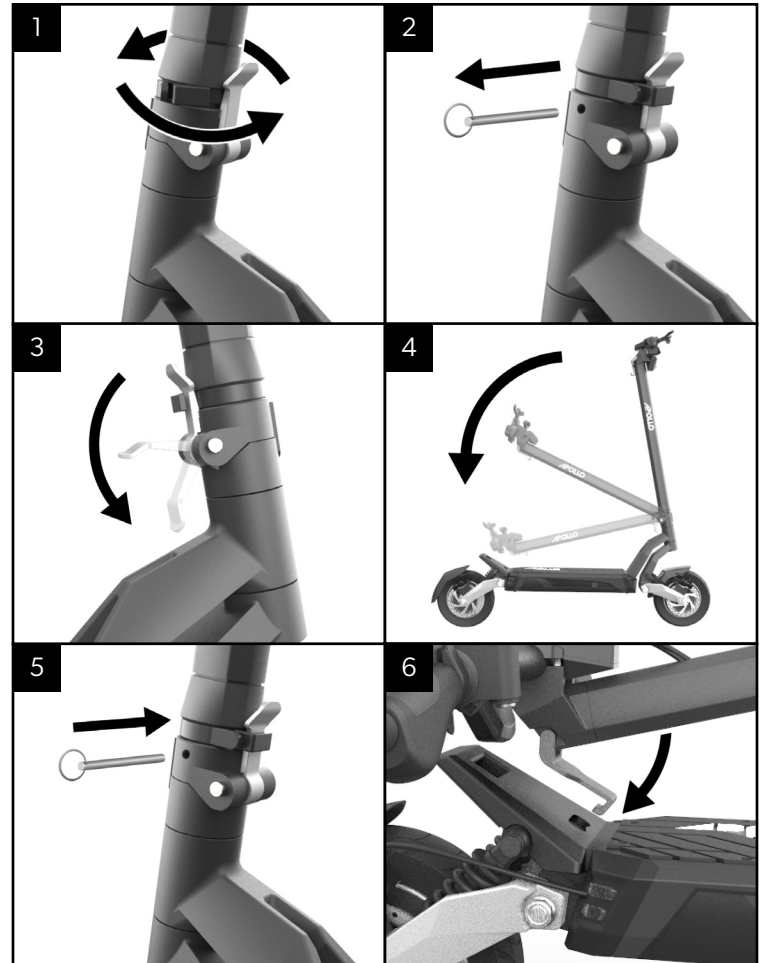

Handlebar features

- | | |
|-----------------------------|---------------|
| 1 Light Switch | 4 Front Brake |
| 2 Gear Console | 5 Display |
| 3 Throttle and Key Ignition | 6 Rear Brake |

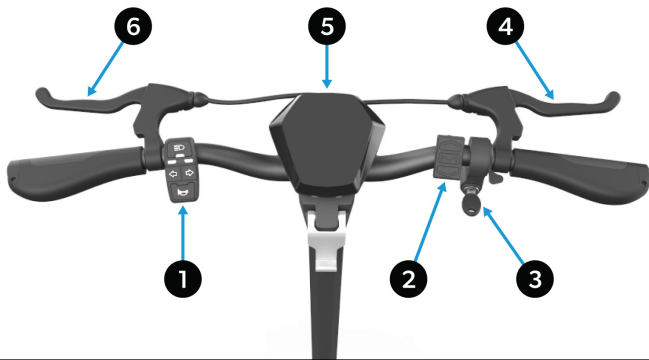

Key Ignition

An effective safety mechanism, the key ignition prevents anyone from powering on the Phantom without the key. To power on the scooter, simply insert the key and turn clockwise. To power off the scooter, turn the key counter clockwise. You can remove the key from the ignition when in this position.

Brakes

The Apollo Phantom is available in two brake configurations - mechanical and hydraulic disc brakes. Both of these brake systems are very similar to bicycle brakes you are likely familiar with. To apply the brakes while riding, simply press on the brake handles. Do so slowly and cautiously, monitoring the braking force being applied.

What is unique to scooters is the rear/front configuration. The left brake handle is the rear brake, while the right brake handle is the front brake. We recommend braking using both brake handles simultaneously divide the braking force between the front and rear mechanisms, rather than overexerting one.

Throttle

The Apollo Phantom comes equipped with a thumb throttle. The throttle is designed to be progressive - small rotation of the throttle will exert proportionately little acceleration. Full rotation of the throttle will trigger maximum output and therefore peak acceleration.

When starting we recommend accelerating slowly to learn the sensitivity of the throttle. Please note that acceleration strength can be adjusted in the settings. Please visit the Settings section and review page 12.

Display

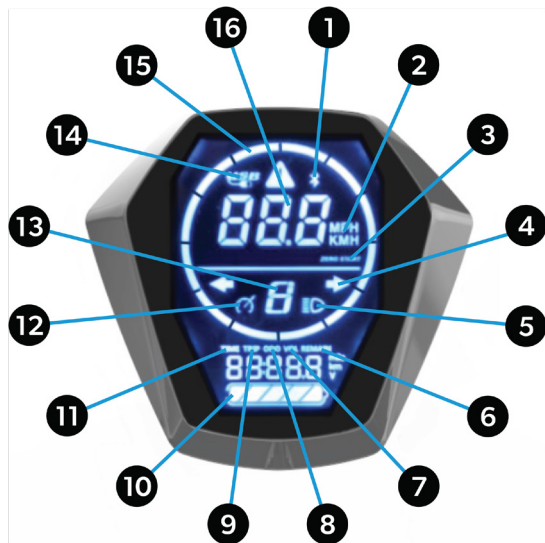

- | | |
|-----------------------------------|-------------------|
| 1 Bluetooth ON/OFF | 9 Trip mileage |
| 2 KMH/MPH | 10 Battery level |
| 3 Kick to start function | 11 Time |
| 4 Turning signals arrows | 12 Cruise control |
| 5 Lights ON/OFF | 13 Gears selector |
| 6 Distance remaining | 14 USB |
| 7 Voltage of the battery | 15 Speed cadran |
| 8 Odometer-Mileage of the scooter | 16 Speed display |

Gear Console



Gear console on the Apollo Phantom consists of three buttons:

- M
- Up
- Down

	PRESS AND HOLD	CLICK
^	NA	Increase gear
M	Power on/off	Change view
v	NA	Decrease gear

These buttons control the display and riding gears. It is important to note that they have different functions depending on whether the buttons are pressed (hold for 3 seconds) or clicked (instant click and click off).

Clicking the M button allows for switching views. Display views always rotate in the following order:

1. TIME

This is the amount of minutes and hours the scooter has been active during a single trip. It resets every time the scooter is turned off.

2. TRIP

This is the amount of miles or kilometers travelled during a single trip. It resets every time the scooter is turned off.

3. ODO (ODOMETER)

The odometer counts the total mileage travelled throughout the lifespan of the scooter. In other words, this is the total distance travelled across all trips. It does not reset when the scooter is turned off.

4. VOL (VOLTAGE)

The voltage represents the approximate voltage level of the battery at any point in time. The voltage value represents battery charge. Please note the maximum and minimum ranges for both models: 

5. REMAIN (REMAINING MILEAGE)

As the name indicates, remaining voltage indicates the approximate distance the scooter can travel based on the amount of charge remaining. Please note this is an approximation that will fluctuate depending on riding speed, terrain, incline, load, temperature, and other factors. It is designed to give riders a rough idea of remaining mileage while holding all of the above variables constant. It is not intended to give precise measure of remaining mileage.

a. **52V:** 42V — 58.8V
(0% charge) (100% charge)

b. **60V:** 48V — 67.2V
(0% charge) (100% charge)

Gear Switch

As indicated in the table above, pressing the up and down buttons will result in a gear increase or decrease. To clarify, electric scooters do not have gears. We simply use the notion of gears to represent their practical impact.

Each gear has an associated top speed:

1. Maximum speed of 30 km/h (18MPH)
2. Maximum speed of 45 km/h (28MPH)
3. No speed limit

Gears are a convenient ways to ensure certain speeds are not exceeded. For example, when riding in a bike lane, a rider might ride in gear one to ensure the speed is appropriate.

⚠ IMPORTANT:

Do not downshift gears when riding. In other words, if riding in gear 3, do not move down to gear 2. Doing this while riding will have a similar effect as downshifting a car while driving, creating strong braking force. This could lead to a potential fall, injury, or death. Shifting up while riding will have a similar effect in the opposite direction, making the scooter accelerate rapidly. Please use the mode switch function with caution.

Light Switch

1 To turn on the front and rear lights, press the light button. To turn off the front and rear lights, press the light button again.

2 The Phantom also features turn signals. To enable either the left or right turn signal, press the respective button.

To turn off the turn signal, simply press the active turn signal button. In other words, if the left turn signal is active, press the left turn signal button to turn it off.

Motor Switch

3 To switch between single and dual motor, press the button once. To revert back to the original setting, press the button again. When in single motor mode, the rear motor will be used by default.

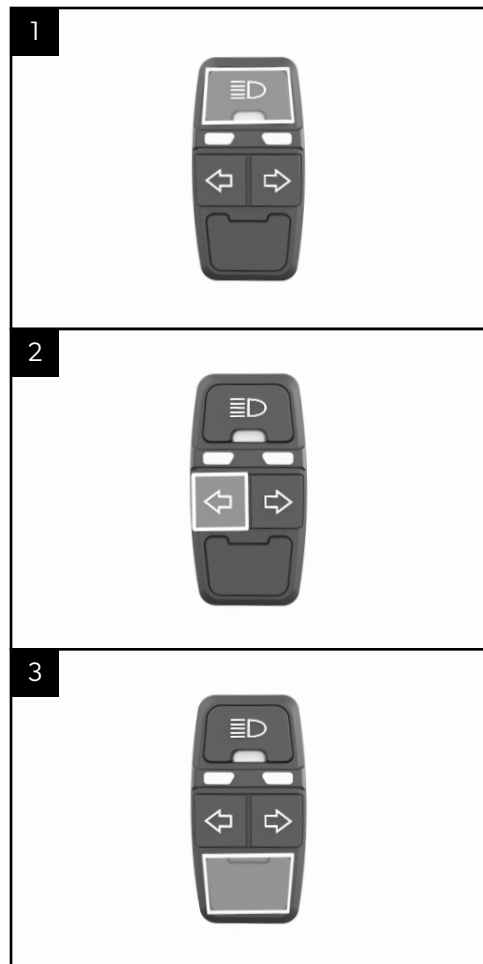

SETTINGS

WARNING:

Incorrect assembly, maintenance, or use of your Apollo scooter can cause component or performance failure, loss of control, serious injury, or death. Even if you're an experienced scooter rider, you must read and understand the entire manual and any documentation provided for subcomponents or accessories before riding. If you are not sure you have the experience, skills, and tools to correctly perform all assembly steps in the manual and the assembly video at apolloscooters.zendesk.com, consult our support team or a local electric scooter shop.

Enter settings mode

The Apollo Phantom comes with a number of configurable settings. To enter settings mode, ensure the Phantom is turned on with the display active. Then press the "gear up" and "gear down" icons simultaneously for 3 seconds.

Your display should now show P00 indicating you have entered settings mode.

Use the "Mode" button to cycle through settings, and use the Gear Up/Down buttons to change the value of a specific setting.

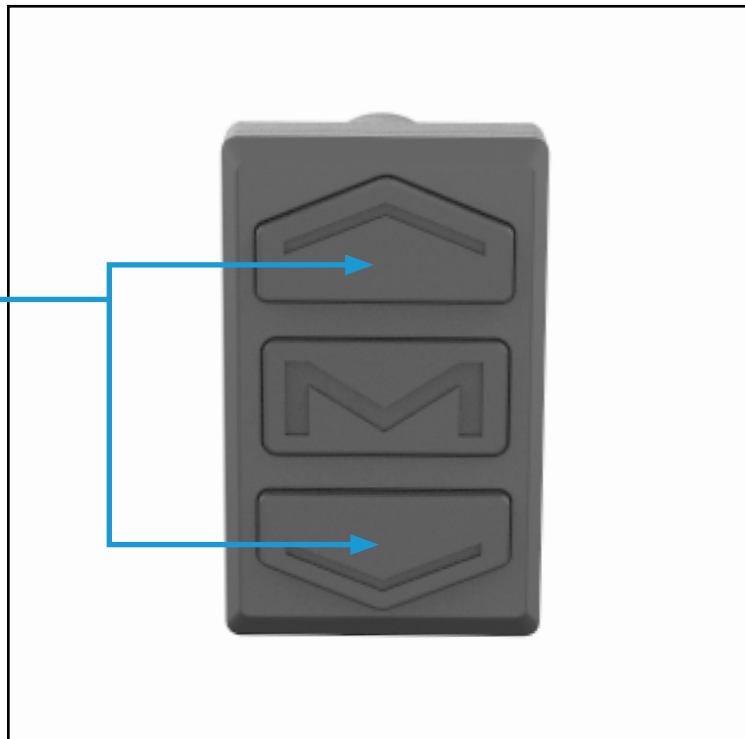

SETTING	FUNCTION	RANGE	DEFAULT VALUE/COMMENTS
P01	Display brightness	1: darkest / 3: brightest	2
P02	Imperial vs. metric units	0: kilometers / 1: miles	NA
P03	Battery voltage	Min: 24V / Max: 72V	Needs to match the voltage of the battery. 52V for 52V version of the Phantom 60V for the 60V version of the Phantom
P04	Auto shut-off timer	Min: 1 minute / Max: 60 minutes	5 minutes
P05	Not currently used		
P06	Wheel diameter (inches)	NA	10 inches
P07	Motor magnet count	Min: 1 / Max: 100	30
P08	Performance limiter	Min: 5% / Max: 100%	
P09	Kick start vs. instant start	0: instant start / 1: kick start	
P10	Not currently used		
P11	Electric brake strength	Min: 0 / Max: 3	Warning: Level 3 is extremely powerful and should only be used by experienced riders. Please test lightly at low speeds before use at high speeds.
P12	Acceleration strength	Min: 1 / Max: 5	
P13	Not currently used		
P14	Not currently used		
P15	Controller cutoff voltage	Min (52V): 42V; Min (60V): 48V	Default for 52V: 42V. Recommended: 43V Default for 60V: 48V. Recommended: 49V
P16	Odometer reset	NA	Press gear up or gear down for 2 seconds to reset odometer
P17	Cruise control	0: off / 1: on	Maintain constant speed for 5 seconds to activate cruise control



Save setting changes

After changing the settings to your preference, you will need to save the new configurations. To do so, press the “gear up” and “gear down” icons simultaneously until your display returns to the home screen.

WARNING:

Incorrect assembly, maintenance, or use of your Apollo scooter can cause component or performance failure, loss of control, serious injury, or death. Even if you’re an experienced scooter rider, you must read and understand the entire manual and any documentation provided for subcomponents or accessories before riding. If you are not sure you have the experience, skills, and tools to correctly perform all assembly steps in the manual and the assembly video at apolloscooters.zendesk.com, consult our support team or a local electric scooter shop.

BATTERY INFO

WARNING:

Incorrect assembly, maintenance, or use of your Apollo scooter can cause component or performance failure, loss of control, serious injury, or death. Even if you're an experienced scooter rider, you must read and understand the entire manual and any documentation provided for subcomponents or accessories before riding. If you are not sure you have the experience, skills, and tools to correctly perform all assembly steps in the manual and the assembly video at apolloscooters.zendesk.com, consult our support team or a local electric scooter shop.

Charging

- Charge the scooter fully after every ride. This will prolong the battery life.
- When charging, wait for the charger light to turn green. The charging process will then be complete and all the cells will have been balanced by the battery management system.
- If not used, power on the scooter once at least once a month to check the charge level. Ideally, the charge level should be between 75% and 90%.

Storage

- The storage temperature needs to be between 10°C–25°C / 50°F–77°F
- For long term storage (such as the winter season), the ideal battery level is approximately 75% (51V for the 52V battery and 58V for the 60V battery). This is based on the fact that at 75% charge level, the energy inside the battery cells is the most stable.

What not to do

- Do not leave the scooter in cold spaces (such as unheated garages or outdoor sheds).
- Do not leave the battery undercharged for long periods of time. This can result in battery damage which is not covered by warranty.
- Do not use chargers that are not sold or approved by Apollo Scooters.

GENERAL SAFETY

WARNING:

Incorrect assembly, maintenance, or use of your Apollo scooter can cause component or performance failure, loss of control, serious injury, or death. Even if you're an experienced scooter rider, you must read and understand the entire manual and any documentation provided for subcomponents or accessories before riding. If you are not sure you have the experience, skills, and tools to correctly perform all assembly steps in the manual and the assembly video at apolloscooters.zendesk.com, consult our support team or a local electric scooter shop.

Road safety & legislation

It is very important that customers perform due diligence, research, and practice caution before riding electric scooters. Electric scooters are vehicles capable of reaching high speeds, and if not used properly, can lead to injury or death. By purchasing an Apollo scooter, you assume the responsibility for these risks. Should you have any questions or concerns, feel free to contact us at support@fluidfreeride.com.

Education

Please read the entire manual carefully. If uncertain about any section, contact us directly at support@fluidfreeride.com or visit our help centre (support.fluidfreeride.com) to find more information. We always recommend starting slow and getting used to the scooter before riding for longer distances.

Age

Apollo Scooters are designed to be used and operated by adults and should not be used by anyone younger than 18 years of age. Should the rider have any disabilities or impairments (visual, hearing, language, seizure, etc), please consult your physician before any ride or purchase of an electric scooter.

Legislation

It is the responsibility of the customer to familiarize themselves with local regulation surrounding electric scooters. Any fines due to illegal or unauthorized use are the responsibility of the customer. It is the responsibility of the rider to comply with all local regulations (such as wearing protective equipment).

Protective Gear

We strongly recommend wearing protective equipment any time the scooter is in use. The equipment includes, but is not limited to, helmets, knee and elbow pads, and protective armour.

IMPORTANT

Do NOT ride under the influence of any drugs, alcohol or substance that could limit or affect judgement, control or rider safety. The rider is fully liable and responsible for riding these scooters with a fully conscious and sober mind, to ensure a safe ride.

MAINTENANCE

NOTE:

This section is available in a video tutorial which can be found on our help centre.

Getting started

Scooters are no different than cars or bikes - if you take care of them by doing a quick tune up every 6 months, you can dramatically extend their lifespan. Follow the below steps to perform a quick, but effective tune up of your Apollo Phantom. If you do not feel comfortable following the instructions, please contact our support team directly or visit a local scooter repair shop.

A tune up consists of the following steps:

1. Tire pressure check
2. Bearing lubrication
3. Suspension lubrication
4. Brake adjustment
5. Screw tightening

You will need a few things to get these done, all of them can be purchased at a local hardware store. If you have difficulty locating these items, contact our support team for help:

- Electric tire pump/inflator
- Jig-a-loo lubricant (or any other lithium grease in spray format)
- WD-40
- Brake pads
- Blue Loctite
- Basic toolkit

These are low cost items that, if used regularly, can make your scooter last dramatically longer. In other words, they're an investment definitely worth making.

Tire pressure

Let's get started with a tire pressure check. This is a simple process that allows us to see the tire pressure of your tires. The ideal tire pressure for Apollo scooters is 50PSI. Few riders know that overinflation is the leading cause of flat tires. In other words, the easiest way to avoid flats is to make sure your tires are correctly inflated.

To get started, place your scooter on a bench, chair, or box. Make sure the tires are easily accessible. We will start with the front tire - to do so, locate the air valve and remove the safety cap.

Attach the air hose and flip the latch to tighten it. You should

be able to power on your electric pump and get a read of the current tire pressure. If it's below 50PSI, start to inflate until the dial reads exactly 50. If the pressure is higher than 50PSI, you can deflate the tire by pressing down on the Air valve mechanism. To do so, find a small object such as a pen or key, and insert it into the air valve. You will hear the air escape. Do so until the tire feels flat, then re-attach the electric pump and inflate until 50PSI.

Afterwards don't forget to put the cover cap back on and repeat the process with the other tire.

Bearing lubrication

Let's grab a can of lubricant - we recommend Jig-a-loo, and move on to your bearings. Your bearings are the connection between the rotating wheels of your scooter and the non-rotating frame that holds them stable. As you use your scooter, the friction can cause the bearing to get worn out - we prevent it from happening by lubricating it regularly.

Start by cleaning the bearing with a clean and wet towel, you can spin the wheel at the same time to make it easier to clean. Once the towel is clean, use WD-40 to clean the bearings. This will remove the tiny particles that are not able to be

cleaned by your wet tissue. It's really important that you add lubricant after this step - since WD-40 is a water disperser, it removes old lubricant and cleans the bearing. If you don't add jig-a-loo after, your bearings will not be lubricated, causing them to get worn out after a few miles.

You will need to spray generously. Spray directly at the bearings and in the general bearing direction, since they are sealed for better protection. Spin your wheel at the same time to make sure the lubricant is being dispersed effectively.



Suspension lubrication

Similar to the bearings, your suspension travels up and down as the spring inside of it contracts and extends. Over time, this friction can cause noises or squeaking sounds. Good news is that this is one of the easiest steps in the maintenance process.

Ensure the suspension is clean prior to using the lubricant. Spray the lubricant inside the spring, on the travel shaft of

the spring located inside the coil. Then spray in the top and bottom pivot points of the suspension.

A good way to distribute the lubricant inside of the suspension spring is to jump on the scooter following the application of lubricant. The up-down movement will create friction which will help distribute the grease.

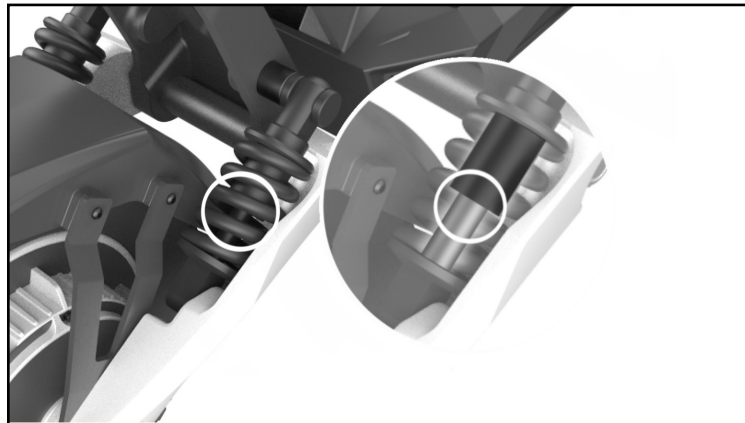

Brake Adjustment

Note: this section will go over how to tighten your brakes. For an in-depth brake adjustment tutorial, please visit the help centre.

Your brakes are arguably the most important component of your scooter. We're strong believers that you need to be able to stop on a dime at all times. Tightening your brakes will be the longest step in the process, but one you definitely do not want to skip.

If you've put over 300 miles on your scooter, you will also want to replace your brake pads. We have included two extra sets for you in the box, but you can always purchase spare ones on our website at apolloscooters.co

The disc brakes and the hydraulic brakes (depending on which version of the Phantom you own) can be tightened in the same way. The first point of control is your brake handle. Locate the adjustment screw at the connection of the brake line to the brake handle.

Turning it counterclockwise will tighten your brake. Turning it clockwise will do the

opposite, making the brake looser. If you have reached the maximum position of the adjustment screw and the brakes are not comfortably tight, proceed to the next step.

Please note this next section only applies to Phantom scooters with mechanical brakes, not hydraulic. For adjustments of hydraulic brake calipers, visit our help centre. Locate the brake caliper corresponding to the brake handle you just adjusted (left = rear, right = front). Identify the calliper adjustment screw at the connection of the brake line to the calliper.

Like before, turning the adjustment screw will tighten your brake. Turning it clockwise will do the opposite, making the brake looser. Pause after each turn to turn the wheel and apply the brake, testing the brake tension. When the brake feels comfortably tight, move on to the other handle/brake.

If your brakes do not feel comfortably tight or perform as expected after these steps, please reference the brake adjustment guide on our help centre.

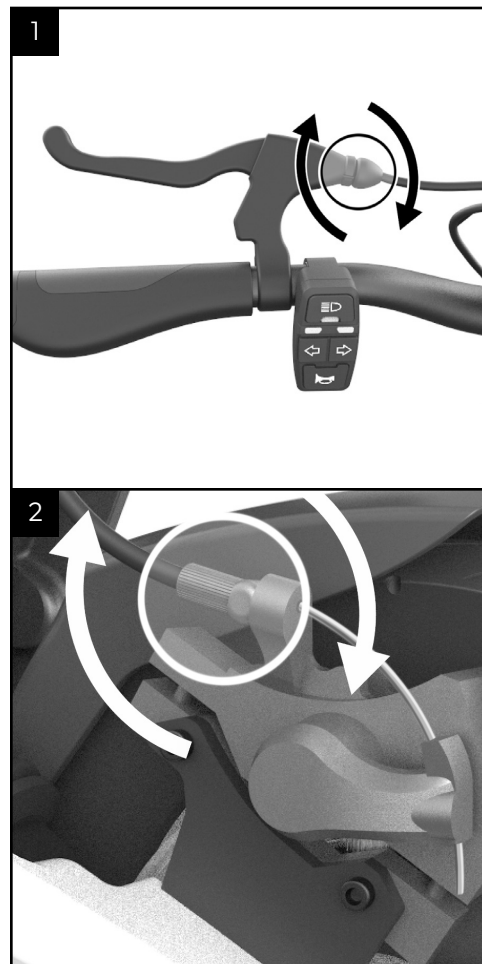

Screw Tightening

As you ride your electric scooter, motors create vibrations. These vibrations can loosen screws over time. We recommend checking your screws every few months to make sure they remain tight. We also recommend applying blue Loctite to further improve their stability.

Use the included toolkit to tighten the screws highlighted on the following graphics.

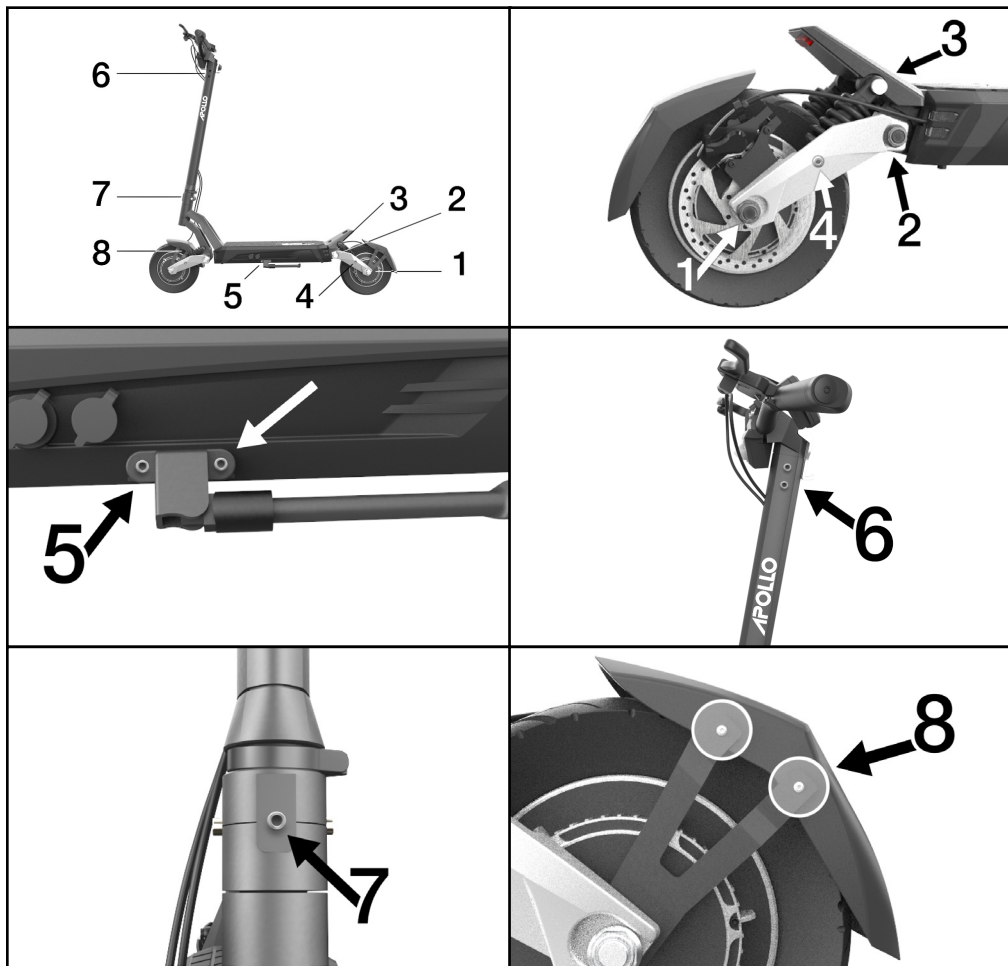

TROUBLESHOOTING

WARNING:

Incorrect assembly, maintenance, or use of your Apollo scooter can cause component or performance failure, loss of control, serious injury, or death. Even if you're an experienced scooter rider, you must read and understand the entire manual and any documentation provided for subcomponents or accessories before riding. If you are not sure you have the experience, skills, and tools to correctly perform all assembly steps in the manual and the assembly video at apolloscooters.zendesk.com, consult our support team or a local electric scooter shop.

Please note:

For full troubleshooting video library, visit our help centre at support@fluidfreeride.com

Error codes

Your scooter comes with a built-in communication system that allows for quicker diagnosis of common issues. Please consult the table below for a classification of codes:

- 0 Normal status
- 1 Keep
- 2 Brake
- 3 PAS sense hitch Riding sign
- 4 6KM/H cruise
- 5 Real-time cruise
- 6 Battery undervoltage
- 7 Motor fault
- 8 Throttle fault
- 9 Controller fault
- 10 Communication receiving fault
- 11 Communication transmission failure
- 12 BMS communication failure
- 13 Headlamp failure

FAQs

WARNING:

Incorrect assembly, maintenance, or use of your Apollo scooter can cause component or performance failure, loss of control, serious injury, or death. Even if you're an experienced scooter rider, you must read and understand the entire manual and any documentation provided for subcomponents or accessories before riding. If you are not sure you have the experience, skills, and tools to correctly perform all assembly steps in the manual and the assembly video at apolloscooters.zendesk.com, consult our support team or a local electric scooter shop.

Charging ports

The Apollo Phantom comes with two charging ports for your convenience. It does not matter which charging port is used when charging with a single charger. You can connect two of the same type of charger at the same time (e.g. two regular chargers or two fast chargers), but do not connect two different chargers at once.

Water resistance

Your scooter is water resistant, however it is not waterproof. This means that although it is generally best to avoid water exposure, the scooter will safely operate in slightly wet conditions such as light rain or wet surfaces. It is not designed for extreme or prolonged exposure to water or humidity. Please note that any damage to the scooter due to water exposure is not covered by warranty.

Voltage fluctuations

You may notice the voltage on your scooter go up and down as you press and release the throttle or perhaps as you ride uphill. This is completely normal and simply implies the scooter is exerting more energy - as tends to be the case when accelerating or climbing a hill. To get an accurate read of your voltage, simply release the throttle and wait for a few seconds until the voltage stabilizes.

WARRANTY & SUPPORT

Warranty Structure

Apollo scooters are covered by a 12-month limited warranty coverage against manufacturing defects. The limited warranty ensures owning a scooter is a smooth and easy process. In the odd event that issues do occur, we designed these policies to be generous and support our customers in getting the necessary help as quickly as possible. Please read on for further details.

12 Month Limited Warranty

Warranty Scope & Eligibility

All Apollo Scooters (“scooters”), are covered with a limited warranty against **manufacturing defects** for a period of one year (12 months), starting on the day the scooter is received by the customer. This limited warranty coverage is only applicable in the following conditions:

- Only the original purchaser (name listed on the shipping address) is entitled to the limited warranty coverage which commences on the day the scooter is received by the customer. The warranty period is terminated on the first day of the second year of ownership, or when the scooter is resold or transferred to another individual (**warranty is by no means transferable under any circumstances**).
- The limited warranty is **only applicable** to the list of covered components, which includes the following:
 - Lithium ion battery
 - Frame
 - Scooter stem

- Controller
 - Handlebar
 - LED lights
 - Motor and motor hub
 - Throttle
 - LCD display and wiring
- The warranty is applicable for the following components **only if defects are reported within the first 30 days or 10KM of use** (whichever comes first):
 - Rims
 - Brake callipers
 - Brake discs
 - Kickstands
 - Forks

If the defect is not reported within this period, the components will not be covered by warranty. Instead, customers will be able to purchase spare parts at wholesale price and will be required to cover any associated shipping expenses.

Any defect report must include an image or video, proving the existence of the defect. When a defective component is reported

and the Apollo engineering team validates the existence of the defect, Apollo will, in its sole discretion, either:

- Repair the defective component at an Apollo service centre (labour included)
- Replace the defective component with a new component (free shipping and part included)

IT REMAINS THE **SOLE DISCRETION OF THE APOLLO ENGINEERING TEAM TO DETERMINE WHETHER THE CORE COMPONENT OR SCOOTER ARE DEFECTIVE AND IF THEY ARE COVERED BY THE LIMITED WARRANTY.**

Limited Warranty does not cover the following:

- Normal wear and tear of any covered component
- The cost or shipping of another scooter box (owners responsibility to keep the original box or purchase a new box if needed due to replacement or repair)
- Damage or defects caused by negli-

gence, improper assembly, modifications, accidents, misuse, improper tools, acts of god, failure to follow user manual/ set up guides, water damage, improper cleaning solutions, improper maintenance (storage during winter for example), extreme/stunt driving, commercial use, unauthorized accessories, upgrades not sold by Apollo

- Accessories or upgrades
- Screws, loss of screws, stripped screws due to over forcing
- Battery failures due to water damage, improper charging, power surges, after market chargers or lack of proper winter storage (75% battery capacity in room temperature)
- Unauthorized service centre repairs or parts will not be covered if damage, failure or loss occurs
- Any refunds or incurred costs such as Uber rides, public transportation, loss of time, consequential, special, punitive or incidental loss, damage to personal property
- Any product rusting, blemishes, loss of colour due to sun exposure over time of usage
- Any orders that have received a charge-back and that are currently under inves-

tigation (until the resolution is solved, warranty will be voided)

Claims Process

APOLLO WILL NOT PROCEED WITH ASSISTANCE UNDER THE LIMITED WARRANTY WITHOUT RECEIVING A VIDEO OR IMAGE SHOWING THE CLAIMED DEFECT FIRST.

In order to effectively help you get the repair or replacement part needed, you must do the following:

1. Submit a repair request by pressing the "submit a request" button on our help centre at: support@fluidfreeride.com
Our support team will review your request and get back to you within one business day.
2. If the engineering team determines the component is in fact defective and needs replacement, they will send you the replacement part and written/video instructions on how to repair or replace the component.

If you do not feel comfortable or do not have the time to do the repair yourself,

you may use one of our repair centres (labour will be free of charge). **However, the customer will be responsible for the shipping cost, taxes and obtaining a scooter box if not still in possession of it.** Customers may also deliver the scooter to the repair centre themselves if desired. Contact us to identify the location centre nearest to you.

To be clear, if your scooter faces a manufacturing defect after 30 days or 10km (whichever comes first), Apollo will **not** replace the scooter with a new unit. Rest assured that Apollo will cover the parts and provide instructions to get this back to safe/riding condition, but replacing the entire unit will not be an option.

THE SOLUTIONS ABOVE ARE APOLLO'S SOLE AND EXCLUSIVE REMEDIES FOR ANY MANUFACTURE CLAIM ON LIMITED WARRANTY. APOLLO IS NOT LIABLE FOR ANY DAMAGES OR LOSSES DURING THIS PROCESS, DIRECTLY OR INDIRECTLY.

Damage During Shipping

Apollo offers the option to purchase addi-

tional shipping insurance to cover the value of your scooter in transit. Without that shipping insurance, any loss or damage during shipping is at the responsibility of the customer. Apollo can assist with opening a claim against the courier for up to \$100. If shipping insurance is purchased and the scooter arrives damaged, Apollo will be able to replace your unit (upon verification from the customer support and engineering teams).

If your scooter does arrive damaged, please contact Apollo and provide any images, documentation and proof **within 10 days** of receipt by submitting this form.

It is the customer's responsibility to inspect the scooter for any damage upon receipt and to reach out to Apollo immediately.

