

# NO MORE EXCUSES

BE FIT NOW 

---

BEFITNOW   
CANADA

2024

# PRODUCT CATALOG

[WWW.BEFITNOW.CA](http://WWW.BEFITNOW.CA)



# COMMERCIAL TRAINER MACHINES

# THE SERIES



# STEEL & LEATHER CUSTOMIZATION

## STEEL COLOR OPTIONS

\*There may be color difference

\*For customized color, please contact with your sales manager



MATTE BLACK



GLOSS DARK  
BLUE



SAND BLACK



PEARL BLACK



SILVER GREY

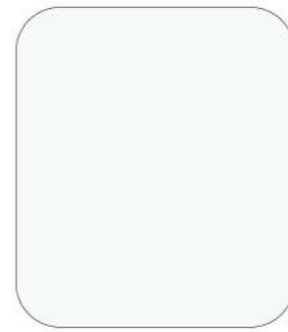

WHITE



YELLOW



ORANGE



RED

## LEATHER COLOR OPTIONS



B6



B10



B3



B1

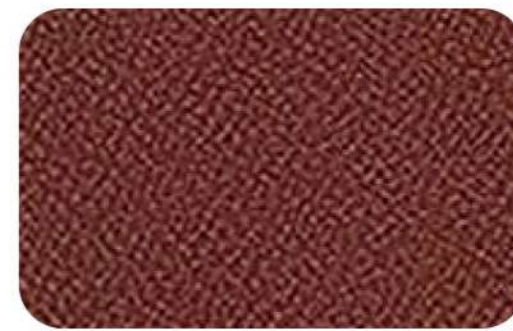

B6



B2

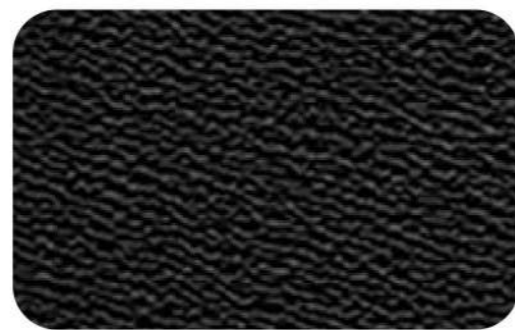

B16

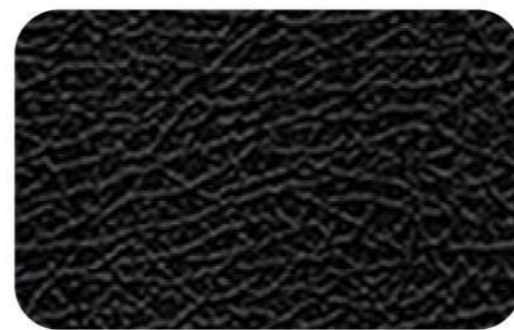

B17

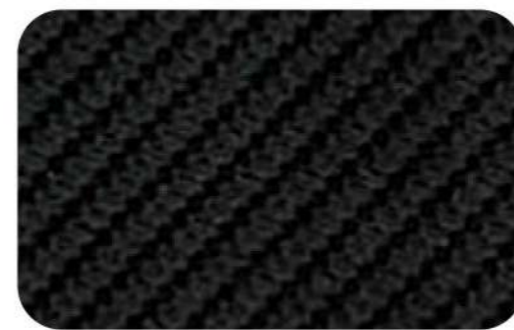

B12



B3



**TY01 - Chest Press**

Weight - 556 lbs  
 Size - 61x59x64 inches  
 Packing Size - 68x44x28 inches  
 Weight Stack - 220 lbs

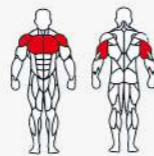

**TY02 - Shoulder Press**

Weight - 589 lbs  
 Size - 78x57x64 inches  
 Packing Size - 64x44x21 inches  
 Weight Stack - 220 lbs

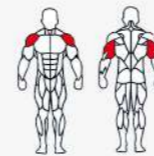

**TY03 - Rowing Machine**

Weight - 530 lbs  
 Size - 52x53x64 inches  
 Packing Size - 64x44x21 inches  
 Weight Stack - 220 lbs



**TY04 - Pec Fly**

Weight - 176 lbs  
 Size - 59x53x82 inches  
 Packing Size - 83x44x22 inches  
 Weight Stack - 190 lbs

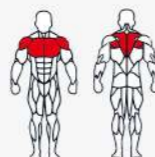

**TY05 - Bicep Curls**

Weight - 485 lbs  
 Size - 54x46x64 inches  
 Packing Size - 64x44x21 inches  
 Weight Stack - 176 lbs

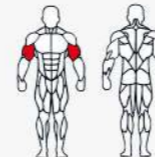

**TY06 - Triceps Press**

Weight - 492 lbs  
 Size - 55x46x64 inches  
 Packing Size - 64x44x21 inches  
 Weight Stack - 176 lbs

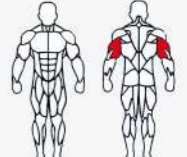



**TY07 - Lateral Raise**

Weight - 523 lbs  
 Size - 53x52x64 inches  
 Packing Size - 72x44x28 inches  
 Weight Stack - 176 lbs



**TY08 - Lat Pulldown**

Weight - 631 lbs  
 Size - 68x62x72 inches  
 Packing Size - 64x46x20 inches  
 Weight Stack - 220 lbs

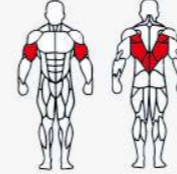

**TY09 - Low Row**

Weight - 507 lbs  
 Size - 69x43x64 inches  
 Packing Size - 72x44x28 inches  
 Weight Stack - 220 lbs

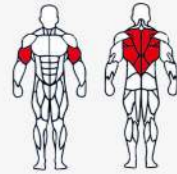

**TY10 - Total Abdominal**

Weight - 500 lbs  
 Size - 56x44x64 inches  
 Packing Size - 64x36x19 inches  
 Weight Stack - 176 lbs

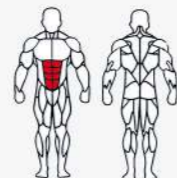

**TY11 - Back Extension**

Weight - 511 lbs  
 Size - 56x46x64 inches  
 Packing Size - 64x36x20 inches  
 Weight Stack - 220 lbs

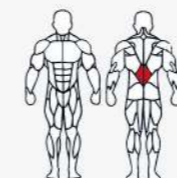

**TY12 - Rotary Torso**

Weight - 556 lbs  
 Size - 44x55x64 inches  
 Packing Size - 64x44x20 inches  
 Weight Stack - 176 lbs

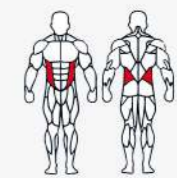



**TY13 - Leg Extension**

Weight - 615 lbs  
 Size - 52x50x64 inches  
 Packing Size - 64x44x20 inches  
 Weight Stack - 220 lbs

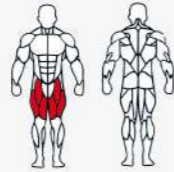

**TY14 - Seated Leg Curls**

Weight - 657 lbs  
 Size - 65x50x64 inches  
 Packing Size - 64x44x20 inches  
 Weight Stack - 220 lbs

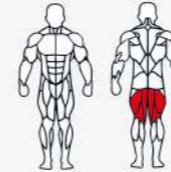

**TY15 - Prone Leg Curls**

Weight - 567 lbs  
 Size - 64x44x64 inches  
 Packing Size - 64x44x20 inches  
 Weight Stack - 220 lbs



**TY16 - Leg Press**

Weight - 787 lbs  
 Size - 78x48x64 inches  
 Packing Size - 72x44x28 inches  
 Weight Stack - 220 lbs

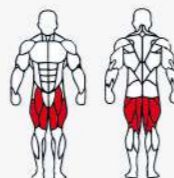

**TY17 - Seated Calf**

Weight - 556 lbs  
 Size - 53x44x64 inches  
 Packing Size - 64x36x18 inches  
 Weight Stack - 220 lbs

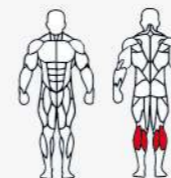

**TY18 - Rear Kick**

Weight - 489 lbs  
 Size - 53x39x64 inches  
 Packing Size - 64x44x21 inches  
 Weight Stack - 220 lbs

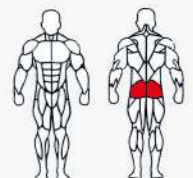



**TY19 - Inner Thigh Adductor**

Weight - 516 lbs  
 Size - 52x59x64 inches  
 Packing Size - 64x44x22 inches  
 Weight Stack - 176 lbs

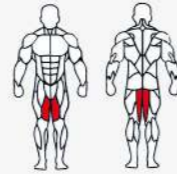

**TY20 - Outer Thigh Abductor**

Weight - 505 lbs  
 Size - 52x55x64 inches  
 Packing Size - 64x44x22 inches  
 Weight Stack - 176 lbs

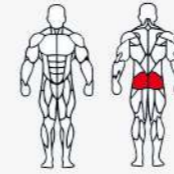

**TY24 - Dip/Chin Assist**

Weight - 732 lbs  
 Size - 62x48x89 inches  
 Packing Size - 93x46x23 inches  
 Weight Stack - 220 lbs

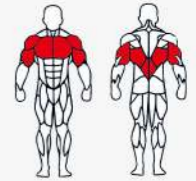

**TY25 - Leg Curl/Extension**

Weight - 648 lbs  
 Size - 68x49x64 inches  
 Packing Size - 64x44x28 inches  
 Weight Stack - 220 lbs

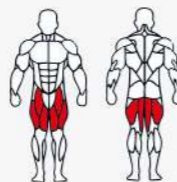

**TY26 - Bicep/Tricep**

Weight - 511 lbs  
 Size - 60x47x64 inches  
 Packing Size - 64x44x21 inches  
 Weight Stack - 176 lbs

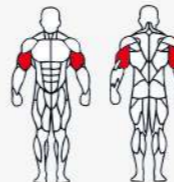

**TY27 - Adductor/Abductor**

Weight - 538 lbs  
 Size - 57x52x64 inches  
 Packing Size - 64x44x22 inches  
 Weight Stack - 176 lbs

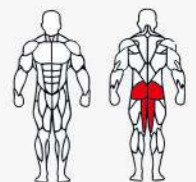





**TY28 - Prone Leg Curl/Extension**

Weight - 582 lbs  
 Size - 50x73x64 inches  
 Packing Size - 64x44x22 inches  
 Weight Stack - 220 lbs

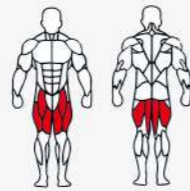

**TY29 - Shoulder Press/Seated Chest Press**

Weight - 611 lbs  
 Size - 59x78x64 inches  
 Packing Size - 83x44x22 inches  
 Weight Stack - 220 lbs

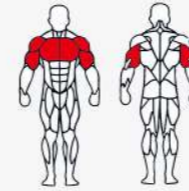

**TY30 - Lat Pulldown/Low Row**

Weight - 631 lbs  
 Size - 73x65x82 inches  
 Packing Size - 87x44x19 inches  
 Weight Stack - 220 lbs

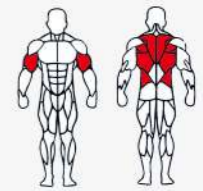

**TY31 - Abdominal Crunch/Low Back**

Weight - 500 lbs  
 Size - 56x47x64 inches  
 Packing Size - 64x44x21 inches  
 Weight Stack - 176 lbs

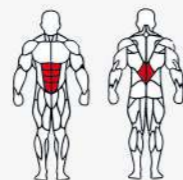

**TY32 - Multi Hip**

Weight - 500 lbs  
 Size - 47x41x64 inches  
 Packing Size - 64x44x29 inches  
 Weight Stack - 176 lbs

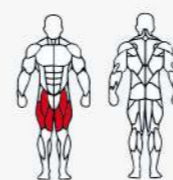

**TY33 - Lat Pulldowns**

Weight - 575 lbs  
 Size - 63x65x82 inches  
 Packing Size - 88x44x19 inches  
 Weight Stack - 220 lbs

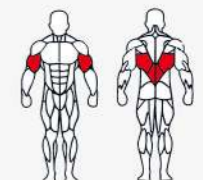



**TY35 - Abdominal**

Weight - 540 lbs  
 Size - 56x53x64 inches  
 Packing Size - 68x44x40 inches  
 Weight Stack - 220 lbs

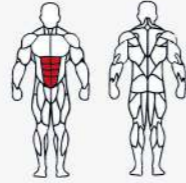

**TY36 - Seated Dip**

Weight - 529 lbs  
 Size - 56x47x64 inches  
 Packing Size - 68x44x22 inches  
 Weight Stack - 176 lbs

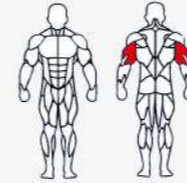

**TY37 - Chest Press**

Weight - 507 lbs  
 Size - 57x57x64 inches  
 Packing Size - 68x44x27 inches  
 Weight Stack - 220 lbs

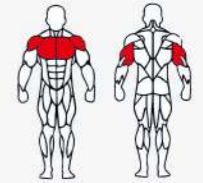

**TY38 - Pec Fly**

Weight - 551 lbs  
 Size - 75x46x81 inches  
 Packing Size - 83x44x22 inches  
 Weight Stack - 176 lbs

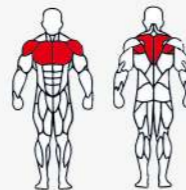

**TY39 - Hip Glute**

Weight - 536 lbs  
 Size - 61x60x64 inches  
 Packing Size - 72x34x24 inches  
 Weight Stack - 220 lbs

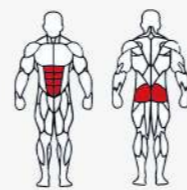

# THE SERIES



# STEEL & LEATHER CUSTOMIZATION

## STEEL COLOR OPTIONS

\*There may be color difference

\*For customized color, please contact with your sales manager



MATTE BLACK



GLOSS DARK  
BLUE



SAND BLACK



PEARL BLACK



SILVER GREY

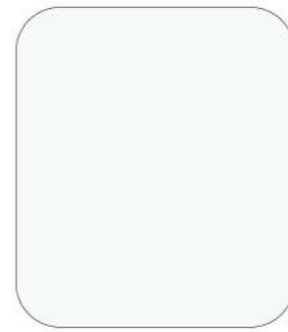

WHITE



YELLOW



ORANGE



RED

## LEATHER COLOR OPTIONS



B6



B10



B3



B1

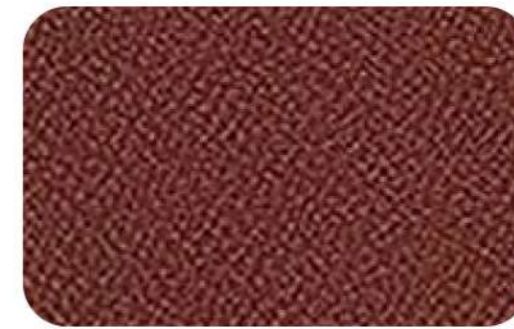

B6



B2



B16

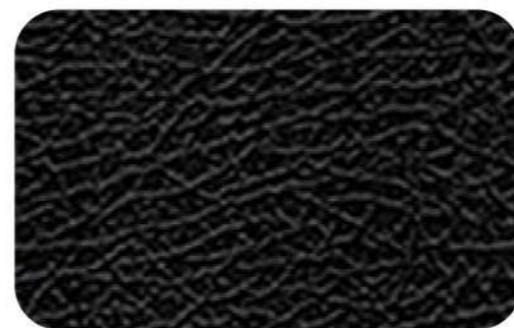

B17

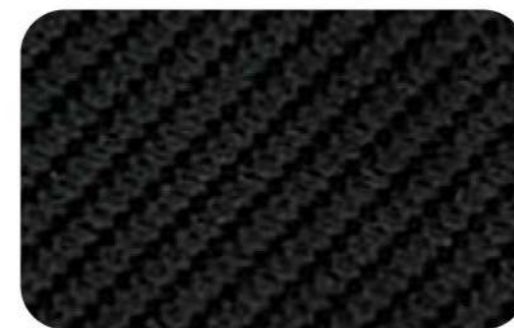

B12



B3



**HS01 - Chest Press**

Weight - 505 lbs  
 Size - 59x43x64 inches  
 Packing Size - 68x44x22 inches  
 Weight Stack - 222 lbs

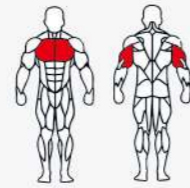

**HS02 - Pear Delt/Pec Fly**

Weight - 503 lbs  
 Size - 50x58x78 inches  
 Packing Size - 80x46x15 inches  
 Weight Stack - 222 lbs

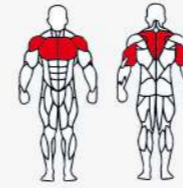

**HS04 - Shoulder Press**

Weight - 494 lbs  
 Size - 54x56x64 inches  
 Packing Size - 68x46x17 inches  
 Weight Stack - 222 lbs

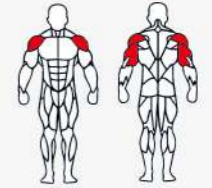

**HS05 - Lateral Raise**

Weight - 515 lbs  
 Size - 43x39x64 inches  
 Packing Size - 68x32x17 inches  
 Weight Stack - 222 lbs

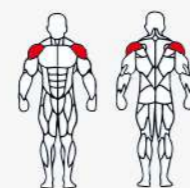

**HS06 - Fixed Pulldown**

Weight - 503 lbs  
 Size - 56x53x75 inches  
 Packing Size - 68x46x17 inches  
 Weight Stack - 222 lbs

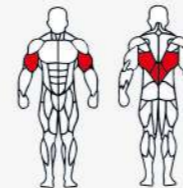

**HS07 - Lat Pulldown**

Weight - 445 lbs  
 Size - 58x34x89 inches  
 Packing Size - 91x52x13 inches  
 Weight Stack - 222 lbs

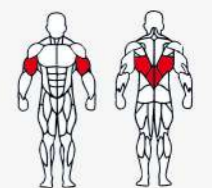



**HS08 - Rowing Machine**

Weight - 516 lbs  
 Size - 50x34x75 inches  
 Packing Size - 80x44x23 inches  
 Weight Stack - 222 lbs

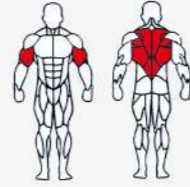

**HS09 - Biceps Curl**

Weight - 437 lbs  
 Size - 45x43x55 inches  
 Packing Size - 68x32x17 inches  
 Weight Stack - 222 lbs

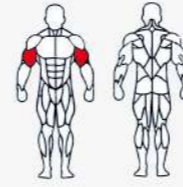

**HS10 - Triceps Extension**

Weight - 460 lbs  
 Size - 45x43x55 inches  
 Packing Size - 64x32x15 inches  
 Weight Stack - 222 lbs

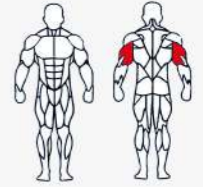

**HS11 - Dip/Chin Assist**

Weight - 671 lbs  
 Size - 47x43x87 inches  
 Packing Size - 89x32x19 inches  
 Weight Stack - 222 lbs

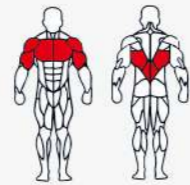

**HS12 - Leg Press**

Weight - 736 lbs  
 Size - 73x42x71 inches  
 Packing Size - 76x44x23 inches  
 Weight Stack - 273 lbs

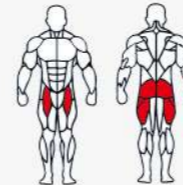

**HS13 - Leg Extension**

Weight - 520 lbs  
 Size - 51x41x64 inches  
 Packing Size - 72x32x20 inches  
 Weight Stack - 222 lbs





HS14 - Seated Leg Curl

Weight - 556 lbs  
Size - 50x41x64 inches  
Packing Size - 72x32x20 inches  
Weight Stack - 222 lbs

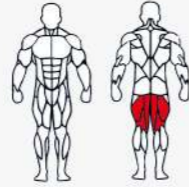

HS15 - Prone Leg Curl

Weight - 483 lbs  
Size - 59x37x55 inches  
Packing Size - 64x32x19 inches  
Weight Stack - 222 lbs

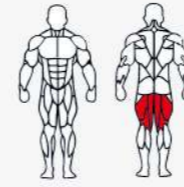

HS16 - Outer Thigh Abductor

Weight - 503 lbs  
Size - 59x28x55 inches  
Packing Size - 60x32x26 inches  
Weight Stack - 222 lbs

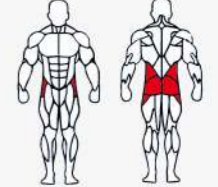

HS17 - Inner Thigh Abductor

Weight - 505 lbs  
Size - 59x28x55 inches  
Packing Size - 60x32x26 inches  
Weight Stack - 222 lbs

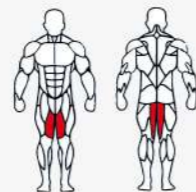

HS18 - Standing Calf Raise

Weight - 485 lbs  
Size - 54x43x72 inches  
Packing Size - 76x32x19 inches  
Weight Stack - 222 lbs

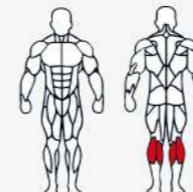

HS20 - Multi Hip

Weight - 529 lbs  
Size - 68x41x71 inches  
Packing Size - 74x44x19 inches  
Weight Stack - 222 lbs

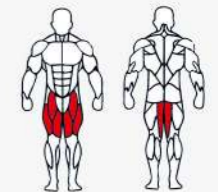



**HS21 - Back Extension**

Weight - 452 lbs  
 Size - 46x39x55 inches  
 Packing Size - 60x32x22 inches  
 Weight Stack - 222 lbs

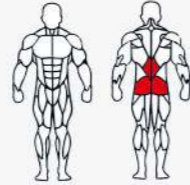

**HS22 - Abdominal Crunch**

Weight - 471 lbs  
 Size - 59x35x55 inches  
 Packing Size - 60x34x19 inches  
 Weight Stack - 222 lbs

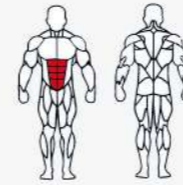

**HS23 - Low Row**

Weight - 507 lbs  
 Size - 78x33x71 inches  
 Packing Size - 72x32x21 inches  
 Weight Stack - 222 lbs

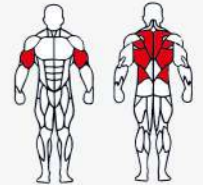

**HS31 - Leg Curl/Extension**

Weight - 564 lbs  
 Size - 51x41x64 inches  
 Packing Size - 72x32x21 inches  
 Weight Stack - 222 lbs

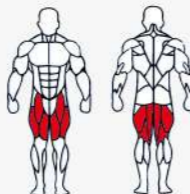

**HS32 - Abductor/Adductor**

Weight - 529 lbs  
 Size - 59x28x55 inches  
 Packing Size - 60x32x26 inches  
 Weight Stack - 222 lbs

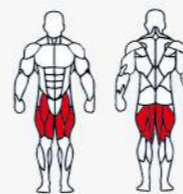

**HS33 - Lat Pulldown/Low Row**

Weight - 551 lbs  
 Size - 85x33x89 inches  
 Packing Size - 91x52x21 inches  
 Weight Stack - 222 lbs

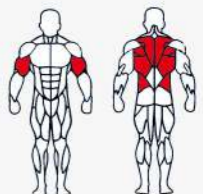





**HS34 - Biceps/Triceps**

Weight - 470 lbs  
 Size - 48x42x55 inches  
 Packing Size - 64x32x19 inches  
 Weight Stack - 222 lbs

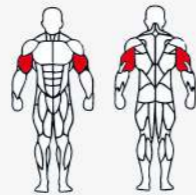

**HS35 - Shoulder Press/Seated Chest Press**

Weight - 595 lbs  
 Size - 74x55x64 inches  
 Packing Size - 76x37x19 inches  
 Weight Stack - 222 lbs

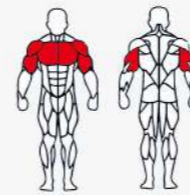

**HS36 - Abdominal Crunch/Low Back**

Weight - 452 lbs  
 Size - 46x41x55 inches  
 Packing Size - 60x32x22 inches  
 Weight Stack - 222 lbs

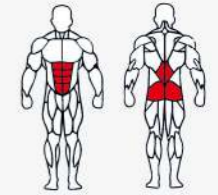

**HS37 - Prone Leg Curl/Leg Extension**

Weight - 496 lbs  
 Size - 61x41x64 inches  
 Packing Size - 72x32x19 inches  
 Weight Stack - 222 lbs

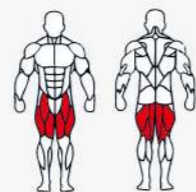

# TIB SERIES



# STEEL & LEATHER CUSTOMIZATION

## STEEL COLOR OPTIONS

\*There may be color difference

\*For customized color, please contact with your sales manager



MATTE BLACK



GLOSS DARK  
BLUE



SAND BLACK



PEARL BLACK



SILVER GREY

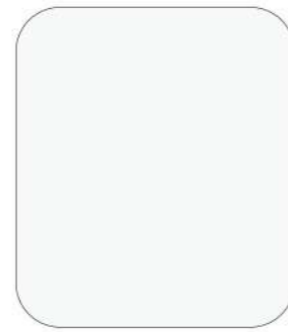

WHITE



YELLOW



ORANGE



RED

## LEATHER COLOR OPTIONS



B6



B10



B3



B1

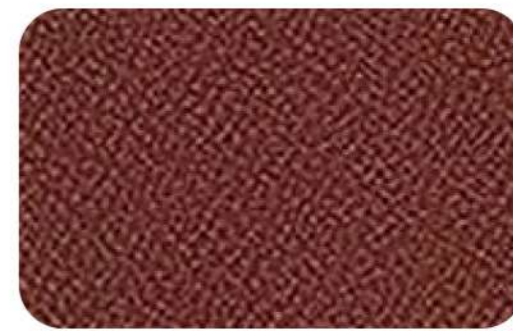

B6



B2



B16

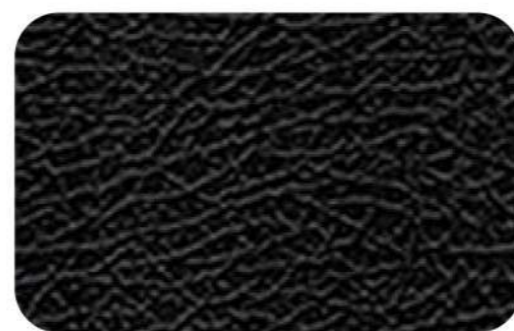

B17

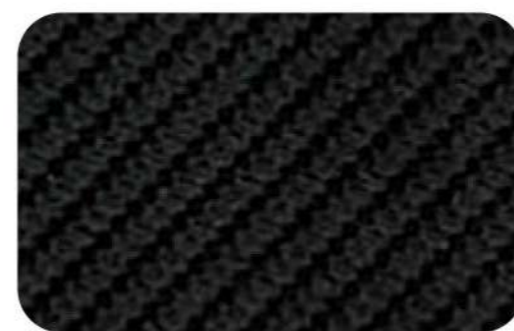

B12



B3



TB16 - Adjustable Crossover

Weight - 688 lbs

Size - 152x28x89 inches

Packing Size - 106x44x31 inches

Weight Stack - 352 lbs

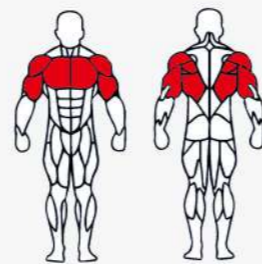

TB15 - Adjustable Crossover

Weight - 727 lbs

Size - 163x41x91 inches

Packing Size - 106x44x22 inches

Weight Stack - 352 lbs

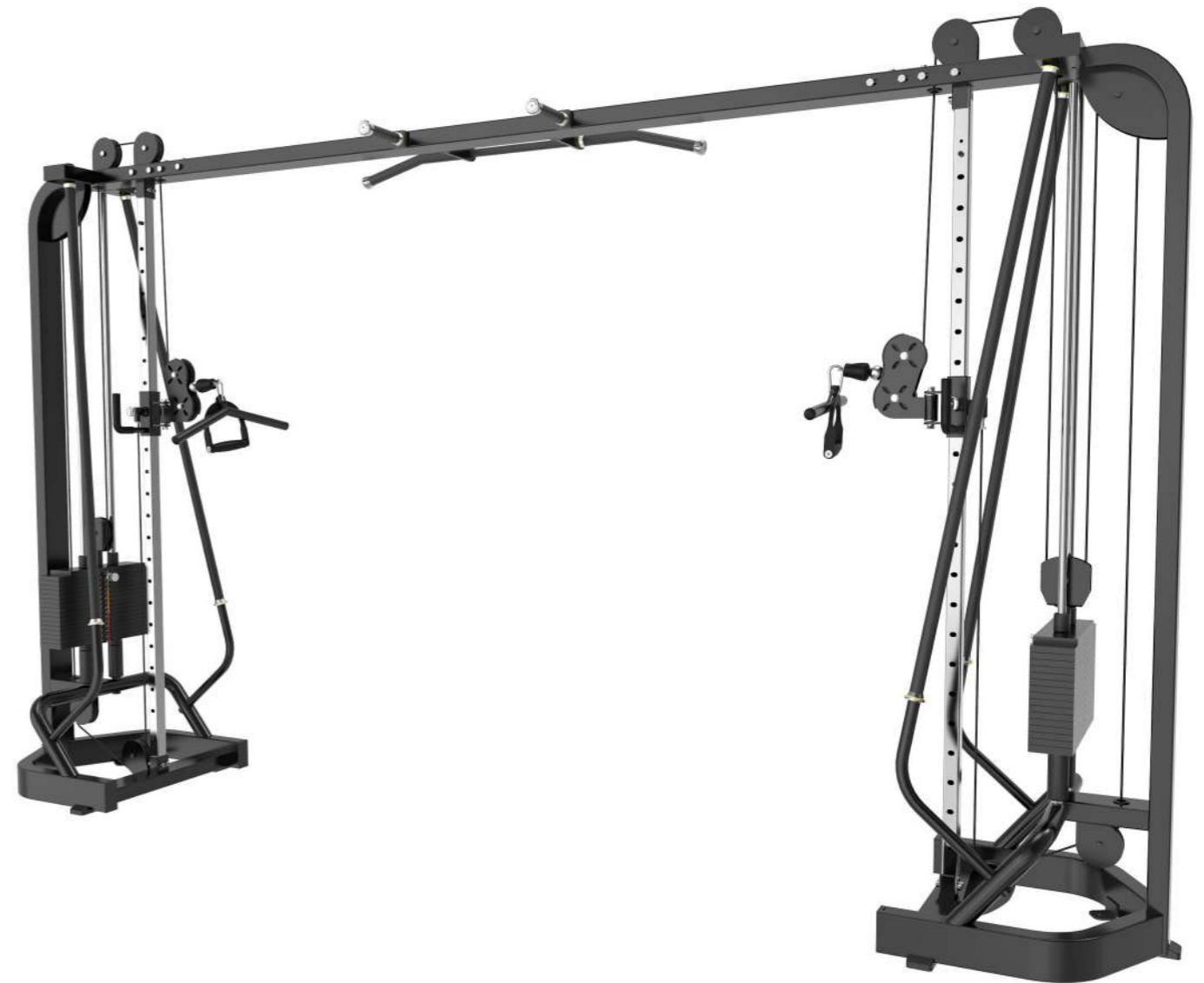
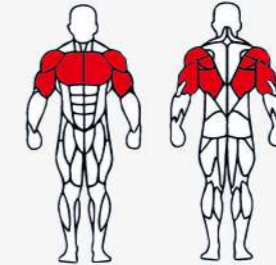



**TB17 - Functional Trainer**

Weight - 781 lbs  
 Size - 41x77x91 inches  
 Packing Size - 93x44x17 inches  
 Weight Stack - 352 lbs

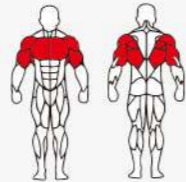

**TB36 - Flat Bench**

Weight - 79 lbs  
 Size - 56x22x17 inches  
 Packing Size - 56x17x10 inches



**TB37 - Adjustable Abdominal Bench**

Weight - 106 lbs  
 Size - 65x26x30 inches  
 Packing Size - 57x23x17 inches



**TB38 - Multi Purpose Bench**

Weight - 62 lbs  
 Size - 47x26x33 inches  
 Packing Size - 49x17x11 inches



**TB39 - Super Bench**

Weight - 99 lbs  
 Size - 55x26x17 inches  
 Packing Size - 54x18x13 inches



**TB41 - Olympic Decline Bench**

Weight - 172 lbs  
 Size - 81x65x48 inches  
 Packing Size - 58x44x15 inches



**TB42 - Olympic Incline Bench**

Weight - 181 lbs

Size - 78x65x55 inches

Packing Size - 58x44x14 inches



**TB43 - Olympic Flat Bench**

Weight - 134 lbs

Size - 66x65x48 inches

Packing Size - 58x44x14 inches



**TB44 - Seated Preacher Curl**

Weight - 101 lbs

Size - 53x31x37 inches

Packing Size - 49x37x13 inches



**TB45 - Back Extension**

Weight - 99 lbs

Size - 44x36x30 inches

Packing Size - 49x38x17 inches



**TB46 - Incline Level Row**

Weight - 243 lbs

Size - 74x33x22 inches

Packing Size - 76x36x20 inches



**TB47 - Vertical Knee Up/Dip**

Weight - 152 lbs

Size - 46x30x63 inches

Packing Size - 68x44x15 inches



**TB48 - Power Cage**

Weight - 298 lbs

Size - 58x52x90 inches

Packing Size - 89x20x17 inches



**TB49 - Dumbbell Rack**

Weight - 146 lbs

Size - 98x30x32 inches

Packing Size - 92x12x7 inches/  
38x29x11 inches



**TB50 - Squat Rack**

Weight - 209 lbs

Size - 70x66x70 inches

Packing Size - 88x44x16 inches



**TB54 - Plate Tree**

Weight - 55 lbs

Size - 23x26x51 inches

Packing Size - 49x17x11 inches



**TB55 - Barbell Rack**

Weight - 152 lbs

Size - 39x32x57 inches

Packing Size - 58x44x14 inches



**TB56 - 45 Degree Leg Press**

Weight - 474 lbs

Size - 86x65x50 inches

Packing Size - 72x44x22 inches



**TB57 - Hack Slide**

Weight - 447 lbs

Size - 88x65x50 inches

Packing Size - 89x56x21 inches



**TB59 - 65 Degree Leg Press/Hack Slide**

Weight - 560 lbs

Size - 93x65x57 inches

Packing Size - 72x60x27 inches



**TB61 - Incline Level Row**

Weight - 132 lbs

Size - 71x39x46 inches

Packing Size - 61x40x19 inches



**TB62 - Seated Calf**

Weight - 117 lbs

Size - 57x25x39 inches

Packing Size - 54x30x14 inches



**TB63 - Smith Machine**

Weight - 626 lbs

Size - 57x86x87 inches

Packing Size - 89x60x17 inches



**TB65 - Super Squat**

Weight - 432 lbs

Size - 78x65x57 inches

Packing Size - 83x44x22 inches





**TB67 - 3 Tier Dumbbell Rack**

Weight - 152 lbs

Size - 65x26x40 inches

Packing Size - 57x32x15 inches



**TB 68 - Power Rack**

Weight - 326 lbs

Size - 63x67x95 inches

Packing Size - 93x40x13 inches



**TB69 - Forearm Machine**

Weight - 243 lbs

Size - 21x25x37 inches

Packing Size - 44x28x19 inches

Weight Stack - 154 lbs



**TB70 - Abdominal Trainer**

Weight - 132 lbs

Size - 60x35x39 inches

Packing Size - 48x45x19 inches



**TB71 - Stretch Trainer**

Weight - 101 lbs

Size - 57x20x45 inches

Packing Size - 48x28x20 inches



**TB73 - 3D Smith Machine**

Weight - 584 lbs

Size - 87x86x89 inches

Packing Size - 91x40x19 inches



**TB80 - Chin Up/DIP & Knee Up**

Weight - 196 lbs

Size - 58x54x87 inches

Packing Size - 83x44x19 inches



**TB86 - Flat/Incline/Decline Bench Press**

Weight - 309 lbs

Size - 41x70x55 / 63x30x23 inches

Packing Size - 58x44x22 inches



**TB87 - Smith/Squat Rack**

Weight - 798 lbs

Size - 88x76x86inches

Packing Size - 89x79x17 inches



**TB88 - Dumbbell Rack**

Weight - 154 lbs

Size - 98x28x32 inches

Packing Size - 92x12x7 inches/ 38x29x11 inches



**TB89C - Funtional Trainer And Squat Rack**

Weight - 1,014 lbs

Size - 76x66x91 inches

Packing Size - 94x55x20 inches

Weight Stack - 353 lbs



**TB93B - Smith/Squat Rack/Funtional Trainer 3 in 1**

Weight - 756 lbs

Size - 69x87x90 inches

Packing Size - 91x62x17 inches

Weight Stack - 353 lbs

# TNM SERIES



# STEEL & LEATHER CUSTOMIZATION

## STEEL COLOR OPTIONS

\*There may be color difference

\*For customized color, please contact with your sales manager



MATTE BLACK



GLOSS DARK  
BLUE



SAND BLACK



PEARL BLACK



SILVER GREY

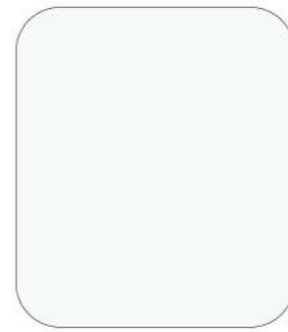

WHITE



YELLOW



ORANGE



RED

## LEATHER COLOR OPTIONS



B6



B10



B3



B1

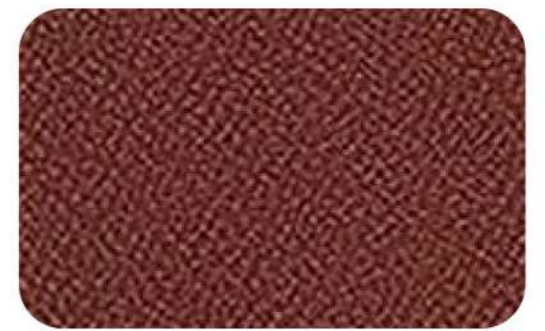

B6



B2

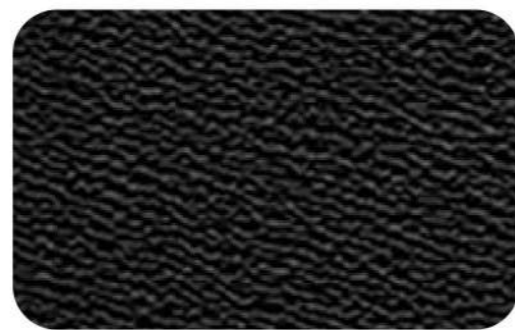

B16

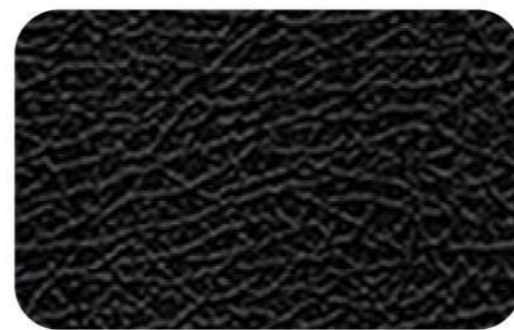

B17

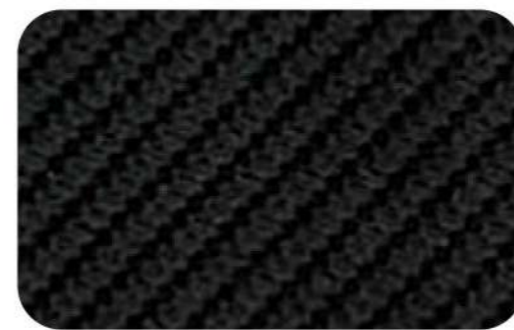

B12



B3



TM01 - Incline Chest Press

Weight - 492 lbs  
 Size - 55.12x45.67x64.17 inches  
 Packing Size - 63.78x44.09x20.87 inches  
 Weight Stack - 176 lbs



TM02 - High Row

Weight - 492 lbs  
 Size - 55.12x45.67x64.17 inches  
 Packing Size - 63.78x44.09x20.87 inches  
 Weight Stack - 176 lbs



TM03 - Iso-Lateral Leg Press

Weight - 492 lbs  
 Size - 55.12x45.67x64.17 inches  
 Packing Size - 63.78x44.09x20.87 inches  
 Weight Stack - 176 lbs



TM04 - Seated Chest Press

Weight - 492 lbs  
 Size - 55.12x45.67x64.17 inches  
 Packing Size - 63.78x44.09x20.87 inches  
 Weight Stack - 176 lbs



TM05 - Seated Chest Press & Lat Pull Down

Weight - 492 lbs  
 Size - 55.12x45.67x64.17 inches  
 Packing Size - 63.78x44.09x20.87 inches  
 Weight Stack - 176 lbs



TM06 - Iso-Lateral Row

Weight - 492 lbs  
 Size - 55.12x45.67x64.17 inches  
 Packing Size - 63.78x44.09x20.87 inches  
 Weight Stack - 176 lbs



TM07 - Wide Chest Press

Weight - 492 lbs  
Size - 55.12x45.67x64.17 inches  
Packing Size - 63.78x44.09x20.87 inches  
Weight Stack - 176 lbs



TM08 - Squat Lunge

Weight - 492 lbs  
Size - 55.12x45.67x64.17 inches  
Packing Size - 63.78x44.09x20.87 inches  
Weight Stack - 176 lbs



TM09 - Smith Machine

Weight - 492 lbs  
Size - 55.12x45.67x64.17 inches  
Packing Size - 63.78x44.09x20.87 inches  
Weight Stack - 176 lbs



TM10 - Vertical Bench

Weight - 492 lbs  
Size - 55.12x45.67x64.17 inches  
Packing Size - 63.78x44.09x20.87 inches  
Weight Stack - 176 lbs



TM11 - Back Extension

Weight - 492 lbs  
Size - 55.12x45.67x64.17 inches  
Packing Size - 63.78x44.09x20.87 inches  
Weight Stack - 176 lbs



TM13 - Seated DY Row

Weight - 492 lbs  
Size - 55.12x45.67x64.17 inches  
Packing Size - 63.78x44.09x20.87 inches  
Weight Stack - 176 lbs



TM14 - Weight Plate Tree

Weight - 492 lbs  
 Size - 55.12x45.67x64.17 inches  
 Packing Size - 63.78x44.09x20.87 inches  
 Weight Stack - 176 lbs



TM15 - Seated Incline Chest Press

Weight - 492 lbs  
 Size - 55.12x45.67x64.17 inches  
 Packing Size - 63.78x44.09x20.87 inches  
 Weight Stack - 176 lbs



TM16 - Front Lat Pulldown

Weight - 492 lbs  
 Size - 55.12x45.67x64.17 inches  
 Packing Size - 63.78x44.09x20.87 inches  
 Weight Stack - 176 lbs



TM17 - Lateral Leg Extension

Weight - 492 lbs  
 Size - 55.12x45.67x64.17 inches  
 Packing Size - 63.78x44.09x20.87 inches  
 Weight Stack - 176 lbs



TM18 - Lateral Leg Curl

Weight - 492 lbs  
 Size - 55.12x45.67x64.17 inches  
 Packing Size - 63.78x44.09x20.87 inches  
 Weight Stack - 176 lbs



TM20 - Arm Curl

Weight - 492 lbs  
 Size - 55.12x45.67x64.17 inches  
 Packing Size - 63.78x44.09x20.87 inches  
 Weight Stack - 176 lbs



**TM21 - Shoulder Press**

Weight - 492 lbs  
 Size - 55.12x45.67x64.17 inches  
 Packing Size - 63.78x44.09x20.87 inches  
 Weight Stack - 176 lbs



**TM22 - Squat High Pull**

Weight - 492 lbs  
 Size - 55.12x45.67x64.17 inches  
 Packing Size - 63.78x44.09x20.87 inches  
 Weight Stack - 176 lbs



**TM23 - Seated Calf Machine**

Weight - 492 lbs  
 Size - 55.12x45.67x64.17 inches  
 Packing Size - 63.78x44.09x20.87 inches  
 Weight Stack - 176 lbs



**TM25 - Low Row**

Weight - 492 lbs  
 Size - 55.12x45.67x64.17 inches  
 Packing Size - 63.78x44.09x20.87 inches  
 Weight Stack - 176 lbs



**TM26 - Seated Chest Press**

Weight - 492 lbs  
 Size - 55.12x45.67x64.17 inches  
 Packing Size - 63.78x44.09x20.87 inches  
 Weight Stack - 176 lbs



**TM27 - Wide Pulldown**

Weight - 492 lbs  
 Size - 55.12x45.67x64.17 inches  
 Packing Size - 63.78x44.09x20.87 inches  
 Weight Stack - 176 lbs





TM28 - Horizontal Bench Press

Weight - 492 lbs  
 Size - 55.12x45.67x64.17 inches  
 Packing Size - 63.78x44.09x20.87 inches  
 Weight Stack - 176 lbs



TM29 - Seated Biceps

Weight - 492 lbs  
 Size - 55.12x45.67x64.17 inches  
 Packing Size - 63.78x44.09x20.87 inches  
 Weight Stack - 176 lbs



TM31 - Olympic Squat Rack

Weight - 492 lbs  
 Size - 55.12x45.67x64.17 inches  
 Packing Size - 63.78x44.09x20.87 inches  
 Weight Stack - 176 lbs



TM34 - Flat Bench

Weight - 492 lbs  
 Size - 55.12x45.67x64.17 inches  
 Packing Size - 63.78x44.09x20.87 inches  
 Weight Stack - 176 lbs



TM37 - Seated Leg Extension

Weight - 492 lbs  
 Size - 55.12x45.67x64.17 inches  
 Packing Size - 63.78x44.09x20.87 inches  
 Weight Stack - 176 lbs



TM38 - Flat Olympic Bench

Weight - 492 lbs  
 Size - 55.12x45.67x64.17 inches  
 Packing Size - 63.78x44.09x20.87 inches  
 Weight Stack - 176 lbs



TM39 - 90 Degree Leg Press

Weight - 492 lbs  
 Size - 55.12x45.67x64.17 inches  
 Packing Size - 63.78x44.09x20.87 inches  
 Weight Stack - 176 lbs



TM42 - Incline Olympic Bench

Weight - 492 lbs  
 Size - 55.12x45.67x64.17 inches  
 Packing Size - 63.78x44.09x20.87 inches  
 Weight Stack - 176 lbs



TM45 - Adjustable Abdominal

Weight - 492 lbs  
 Size - 55.12x45.67x64.17 inches  
 Packing Size - 63.78x44.09x20.87 inches  
 Weight Stack - 176 lbs



TM46 - Multi Bench

Weight - 492 lbs  
 Size - 55.12x45.67x64.17 inches  
 Packing Size - 63.78x44.09x20.87 inches  
 Weight Stack - 176 lbs



TM48 - Laydown Pecfly

Weight - 492 lbs  
 Size - 55.12x45.67x64.17 inches  
 Packing Size - 63.78x44.09x20.87 inches  
 Weight Stack - 176 lbs



TM50 - Dumbbell Rack

Weight - 492 lbs  
 Size - 55.12x45.67x64.17 inches  
 Packing Size - 63.78x44.09x20.87 inches  
 Weight Stack - 176 lbs



TM51 - 75 Degree Incline Bench

Weight - 492 lbs  
Size - 55.12x45.67x64.17 inches  
Packing Size - 63.78x44.09x20.87 inches  
Weight Stack - 176 lbs



TM55 - Decline Bench

Weight - 492 lbs  
Size - 55.12x45.67x64.17 inches  
Packing Size - 63.78x44.09x20.87 inches  
Weight Stack - 176 lbs



TM56 - Inline Pecfly

Weight - 492 lbs  
Size - 55.12x45.67x64.17 inches  
Packing Size - 63.78x44.09x20.87 inches  
Weight Stack - 176 lbs



TM58 - Lateral Raise

Weight - 492 lbs  
Size - 55.12x45.67x64.17 inches  
Packing Size - 63.78x44.09x20.87 inches  
Weight Stack - 176 lbs



TM59 - Abductor

Weight - 492 lbs  
Size - 55.12x45.67x64.17 inches  
Packing Size - 63.78x44.09x20.87 inches  
Weight Stack - 176 lbs



TM61 - Bar Rack

Weight - 492 lbs  
Size - 55.12x45.67x64.17 inches  
Packing Size - 63.78x44.09x20.87 inches  
Weight Stack - 176 lbs



TM66 - Kneeling Leg Curl

Weight - 492 lbs  
 Size - 55.12x45.67x64.17 inches  
 Packing Size - 63.78x44.09x20.87 inches  
 Weight Stack - 176 lbs



TM67 - Seated Dip

Weight - 492 lbs  
 Size - 55.12x45.67x64.17 inches  
 Packing Size - 63.78x44.09x20.87 inches  
 Weight Stack - 176 lbs



TM68 - Pull Over

Weight - 492 lbs  
 Size - 55.12x45.67x64.17 inches  
 Packing Size - 63.78x44.09x20.87 inches  
 Weight Stack - 176 lbs



TM70 - Abductor

Weight - 492 lbs  
 Size - 55.12x45.67x64.17 inches  
 Packing Size - 63.78x44.09x20.87 inches  
 Weight Stack - 176 lbs



TM71 - V Squat

Weight - 492 lbs  
 Size - 55.12x45.67x64.17 inches  
 Packing Size - 63.78x44.09x20.87 inches  
 Weight Stack - 176 lbs



TM72 - Abdominal

Weight - 492 lbs  
 Size - 55.12x45.67x64.17 inches  
 Packing Size - 63.78x44.09x20.87 inches  
 Weight Stack - 176 lbs



TM73 - Decline Olympic Bench

Weight - 492 lbs  
 Size - 55.12x45.67x64.17 inches  
 Packing Size - 63.78x44.09x20.87 inches  
 Weight Stack - 176 lbs



TM75 - Abdominal Bench

Weight - 492 lbs  
 Size - 55.12x45.67x64.17 inches  
 Packing Size - 63.78x44.09x20.87 inches  
 Weight Stack - 176 lbs



TM76 - Seated/Standing Shrug

Weight - 492 lbs  
 Size - 55.12x45.67x64.17 inches  
 Packing Size - 63.78x44.09x20.87 inches  
 Weight Stack - 176 lbs



TM77 - Abdominal Workstation

Weight - 492 lbs  
 Size - 55.12x45.67x64.17 inches  
 Packing Size - 63.78x44.09x20.87 inches  
 Weight Stack - 176 lbs



TM80 - Stand Calf

Weight - 492 lbs  
 Size - 55.12x45.67x64.17 inches  
 Packing Size - 63.78x44.09x20.87 inches  
 Weight Stack - 176 lbs



TM87 - Adjustable Bench

Weight - 492 lbs  
 Size - 55.12x45.67x64.17 inches  
 Packing Size - 63.78x44.09x20.87 inches  
 Weight Stack - 176 lbs



TM73 - Decline Olympic Bench

Weight - 492 lbs  
 Size - 55.12x45.67x64.17 inches  
 Packing Size - 63.78x44.09x20.87 inches  
 Weight Stack - 176 lbs



TM75 - Abdominal Bench

Weight - 492 lbs  
 Size - 55.12x45.67x64.17 inches  
 Packing Size - 63.78x44.09x20.87 inches  
 Weight Stack - 176 lbs



TM76 - Seated/Standing Shrug

Weight - 492 lbs  
 Size - 55.12x45.67x64.17 inches  
 Packing Size - 63.78x44.09x20.87 inches  
 Weight Stack - 176 lbs



TM77 - Abdominal Workstation

Weight - 492 lbs  
 Size - 55.12x45.67x64.17 inches  
 Packing Size - 63.78x44.09x20.87 inches  
 Weight Stack - 176 lbs



TM80 - Stand Calf

Weight - 492 lbs  
 Size - 55.12x45.67x64.17 inches  
 Packing Size - 63.78x44.09x20.87 inches  
 Weight Stack - 176 lbs



TM87 - Adjustable Bench

Weight - 492 lbs  
 Size - 55.12x45.67x64.17 inches  
 Packing Size - 63.78x44.09x20.87 inches  
 Weight Stack - 176 lbs



TM01- Inclined Chest Press

Weight: 324 lbs

Size: 65 in x 38 in x 76 in

Packing Size: 64 in x 40 in x 22 in

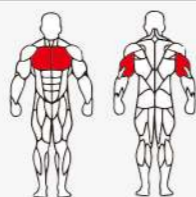

TM02- High Row

Weight: 351 lbs

Size: 63 in x 60 in x 79 in

Packing Size: 64 in x 44 in x 22 in

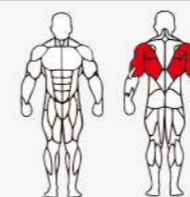

TM03- Iso-Lateral Leg Press

Weight: 319 lbs

Size: 70 in x 67 in x 59 in

Packing Size: 66 in x 44 in x 30 in

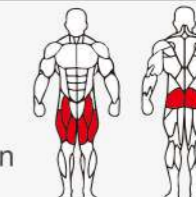

TM04- Seated Chest Press

Weight: 335 lbs

Size: 51 in x 72 in x 73 in

Packing Size: 64 in x 44 in x 22 in

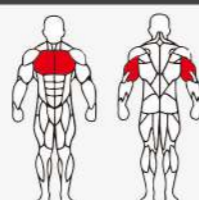

TM05- Seated Chest Press & Lateral Pull Down

Weight: 413 lbs

Size: 81 in x 67 in x 80 in

Packing Size: 83 in x 44 in x 22 in

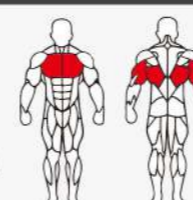

TM06- Iso-Lateral Row

Weight: 265 lbs

Size: 59 in x 56 in x 54 in

Packing Size: 64 in x 40 in x 22 in

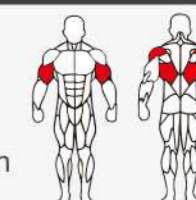



TM07- Wide Chest Press

Weight: 349 lbs

Size: 46 in x 79 in x 68 in

Packing Size: 64 in x 44 in x 22 in

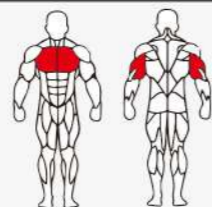

TM08- Squat Lunge

Weight: 265 lbs

Size: 64 in x 54 in x 35 in

Packing Size: 58 in x 40 in x 42 in

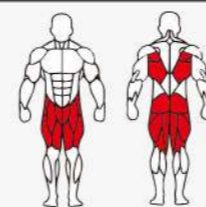

TM09- Smith Machine

Weight: 408 lbs

Size: 96 in x 50 in x 90 in

Packing Size: 91 in x 52 in x 19 in



TM10- Vertical Bench

Weight: 220 lbs

Size: 72 in x 49 in x 65 in

Packing Size: 68 in x 44 in x 19 in

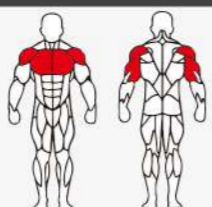

TM11- Back Extension

Weight: 101 lbs

Size: 54 in x 29 in x 31 in

Packing Size: 48 in x 28 in x 20 in

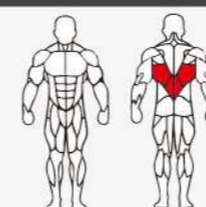

TM13- Seated Row

Weight: 353 lbs

Size: 58 in x 64 in x 84 in

Packing Size: 74 in x 54 in x 20 in

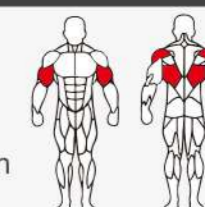





TM14- IWeight Plate Tree

Weight: 66 lbs

Size: 29 in x 25 in x 41 in

Packing Size: 44 in x 32 in x 9 in



TM15- Seated Incline Chest Press

Weight: 287 lbs

Size: 51 in x 67 in x 60 in

Packing Size: 55 in x 44 in x 22 in

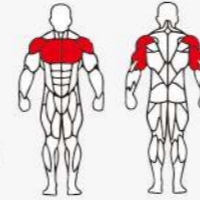

TM16- Front Lat Pulldown

Weight: 344 lbs

Size: 72 in x 55 in x 78 in

Packing Size: 78 in x 44 in x 19 in

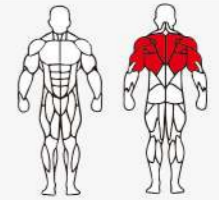

TM17- Lateral Leg Extension

Weight: 276 lbs

Size: 65 in x 74 in x 58 in

Packing Size: 64 in x 44 in x 22 in

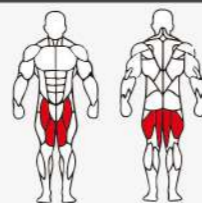

TM18- Lateral Leg Curl

Weight: 220 lbs

Size: 65 in x 80 in x 39 in

Packing Size: 56 in x 40 in x 26 in

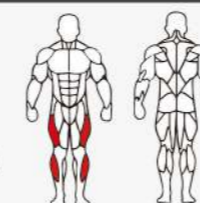

TM20- Arm Curl

Weight: 161 lbs

Size: 46 in x 31 in x 43 in

Packing Size: 58 in x 44 in x 16 in

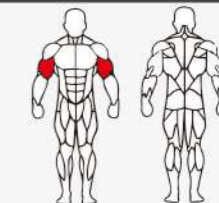



TM21- Shoulder Press Press

Weight: 319 lbs

Size: 56 in x 73 in x 74 in

Packing Size: 64 in x 44 in x 21 in

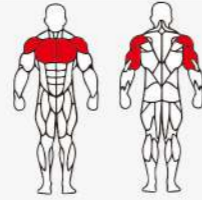

TM22- Squat High Pull

Weight: 209 lbs

Size: 72 in x 64 in x 41 in

Packing Size: 58 in x 40 in x 22 in

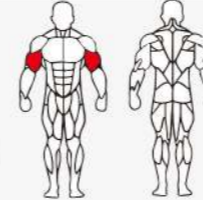

TM23- ISeated Calf Machine

Weight: 150 lbs

Size: 48 in x 30 in x 34 in

Packing Size: 54 in x 30 in x 16 in

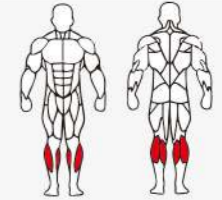

TM25- Low Row

Weight: 287 lbs

Size: 50 in x 54 in x 66 in

Packing Size: 64 in x 44 in x 22 in

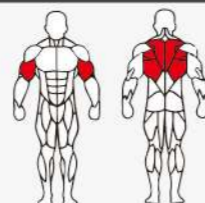

TM26- Seated Chest Press

Weight: 342 lbs

Size: 47 in x 74 in x 71 in

Packing Size: 68 in x 44 in x 22 in

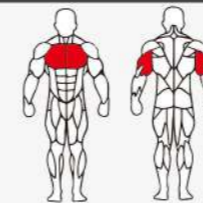

TM27- Wide Pulldown

Weight: 319 lbs

Size: 69 in x 46 in x 79 in

Packing Size: 64 in x 44 in x 22 in

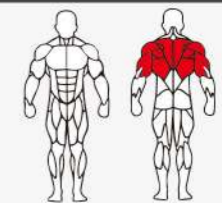



TM28- Horizontal Bench Press

Weight: 212 lbs

Size: 69 in x 68 in x 44 in

Packing Size: 64 in x 44 in x 22 in

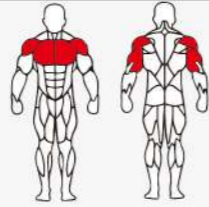

TM29- Seated Biceps

Weight: 216 lbs

Size: 59 in x 57 in x 58 in

Packing Size: 56 in x 44 in x 20 in

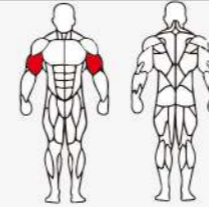

TM31- Olympic Squat Rack

Weight: 243 lbs

Size: 71 in x 67 in x 73 in

Packing Size: 70 in x 34 in x 15 in



TM34- Flat Bench

Weight: 49 lbs

Size: 50 in x 19 in x 16 in

Packing Size: 49 in x 17 in x 10 in



TM37- Seated Leg Extension

Weight: 340 lbs

Size: 58 in x 73 in x 42 in

Packing Size: 56 in x 40 in x 22 in

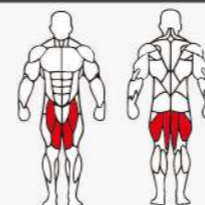

TM38- Flat Olympic Bench

Weight: 185 lbs

Size: 64 in x 67 in x 51 in

Packing Size: 56 in x 40 in x 20 in

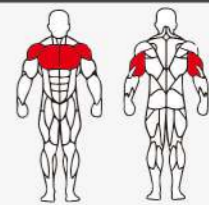



TM39- 90 Degree Leg Press

Weight: 331 lbs

Size: 52 in x 67 in x 71 in

Packing Size: 76 in x 44 in x 15 in

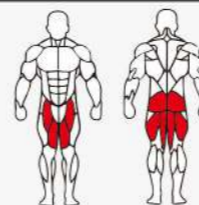

TM42- Incline Olympic Bench

Weight: 201 lbs

Size: 64 in x 67 in x 60 in

Packing Size: 66 in x 34 in x 20 in

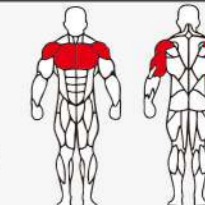

TM45- Adjustable Abdominal

Weight: 99 lbs

Size: 58 in x 30 in x 41 in

Packing Size: 56 in x 32 in x 24 in

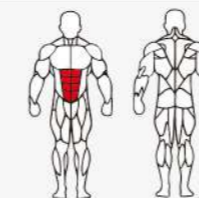

TM46- Multi Bench

Weight: 198 lbs

Size: 73 in x 46 in x 55 in

Packing Size: 48 in x 28 in x 22 in

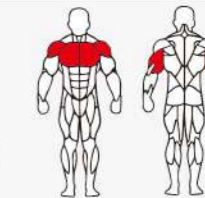



TM48- Laydown Pecfly

Weight: 164 lbs

Size: 75 in x 42 in x 35 in

Packing Size: 66 in x 33 in x 24 in

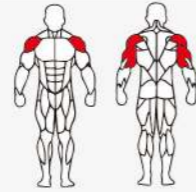

TM50- Dumbbell Rack

Weight: 137 lbs

Size: 82 in x 20 in x 31 in

Packing Size: 92 in x 12 in x 7 in



TM51- 75 Degree Incline Bench

Weight: 60 lbs

Size: 49 in x 25 in x 38 in

Packing Size: 57 in x 23 in x 17 in



TM55- Decline Bench

Weight: 115 lbs

Size: 65 in x 24 in x 35 in

Packing Size: 52 in x 32 in x 26 in

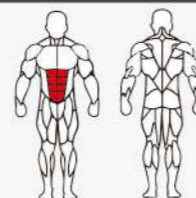

TM56- Incline Pecfly

Weight: 231 lbs

Size: 69 in x 65 in x 47 in

Packing Size: 62 in x 29 in x 19 in

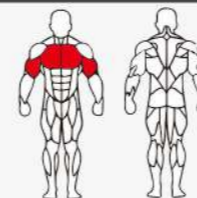

TM58- Lateral Raise

Weight: 203 lbs

Size: 37 in x 54 in x 52 in

Packing Size: 54 in x 36 in x 22 in

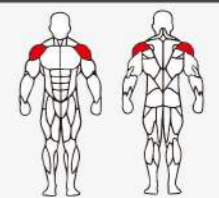



TM59- Abductor

Weight: 284 lbs

Size: 70 in x 47 in x 47 in

Packing Size: 68 in x 44 in x 22 in

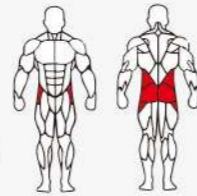

TM61- Bar Rack

Weight: 132 lbs

Size: 26 in x 33 in x 59 in

Packing Size: 62 in x 29 in x 11 in



TM66- Kneeling Leg Curl

Weight: 243 lbs

Size: 46 in x 71 in x 56 in

Packing Size: 64 in x 44 in x 22 in

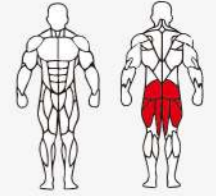

TM67- Seated Dip

Weight: 276 lbs

Size: 67 in x 63 in x 42 in

Packing Size: 74 in x 40 in x 22 in

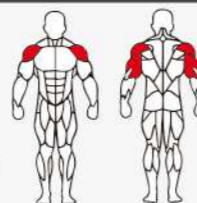

TM68- Pullover

Weight: 353 lbs

Size: 66 in x 76 in x 72 in

Packing Size: 68 in x 44 in x 22 in

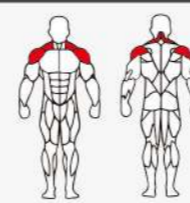

TM70- Adductor

Weight: 287 lbs

Size: 64 in x 47 in x 47 in

Packing Size: 68 in x 44 in x 22 in

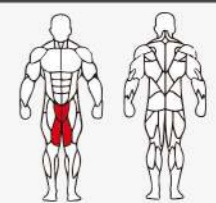



TM71- V Squat

Weight: 414 lbs

Size: 43 in x 79 in x 63 in

Packing Size: 54 in x 44 in x 24 in

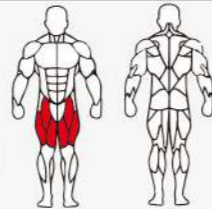

TM72- Abdominal

Weight: 243 lbs

Size: 81 in x 66 in x 51 in

Packing Size: 68 in x 36 in x 22 in

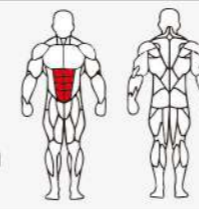

TM73- Decline Olympic Bench

Weight: 130 lbs

Size: 65 in x 24 in x 33 in

Packing Size: 66 in x 32 in x 24 in

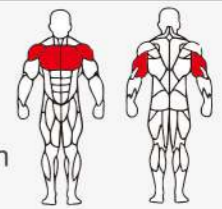

TM75- Abdominal Bench

Weight: 206 lbs

Size: 43 in x 61 in x 48 in

Packing Size: 48 in x 40 in x 22 in

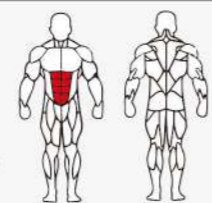

TM76- Seated/ Standing Shrug

Weight: 206 lbs

Size: 43 in x 61 in x 48 in

Packing Size: 48 in x 40 in x 22 in



TM77- Abdominal Work Station

Weight: 240 lbs

Size: 88 in x 37 in x 73 in

Packing Size: 72 in x 40 in x 26 in

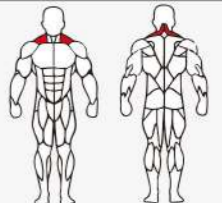

# TM - STRENGTH SERIES / PLATE LOADED



TM80- Stand Calf

Weight: 163 lbs

Size: 48 in x 48 in x 60 in

Packing Size: 56 in x 48 in x 17 in

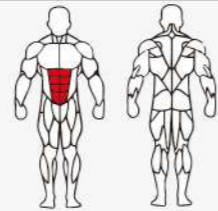

TM87- Adjustable Bench

Weight: 128 lbs

Size: 62 in x 22 in x 18 in

Packing Size: 57 in x 19 in x 15 in







TM89- Roman Chair

Weight: 130 lbs

Size: 60 in x 29 in x 31 in

Packing Size: 48 in x 28 in x 20 in

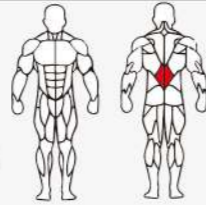

TM90- Power Cage

Weight: 507 lbs

Size: 77 in x 68 in x 111 in

Packing Size: 109 in x 40 in x 20 in



TM91- 45 Degree Leg Press

Weight: 564 lbs

Size: 94 in x 64 in x 59 in

Packing Size: 89 in x 44 in x 33 in



TM92- Abdominal

Weight: 93 lbs

Size: 40 in x 22 in x 20 in

Packing Size: 42 in x 24 in x 16 in



TM93- Adjustable Abdominal & Back Extension

Weight: 388 lbs

Size: 69 in x 43 in x 46 in

Packing Size: 67 in x 43 in x 25 in



TM94- Stand Torso

Weight: 46 lbs

Size: 29 in x 22 in x 54 in

Packing Size: 54 in x 24 in x 9 in



TM95- Torso Machine

Weight: 86 lbs

Size: 68 in x 19 in x 50 in

Packing Size: 66 in x 24 in x 14 in

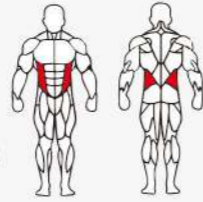

TM96- Barbell Rack

Weight: 176 lbs

Size: 39 in x 29 in x 60 in

Packing Size: 66 in x 44 in x 11 in



TM97- Adjust Bench 3 Degree

Weight: 168 lbs

Size: 68 in x 20 in x 22 in

Packing Size: 70 in x 22 in x 15 in



TM99- Roger Supper Vertical Leg Press

Weight: 386 lbs

Size: 58 in x 64 in x 71 in

Packing Size: 76 in x 40 in x 20 in



TM100- Chin Up

Weight: 152 lbs

Size: 49 in x 48 in x 90 in

Packing Size: 89 in x 20 in x 17 in



TM101- Squat Trainer

Weight: 485 lbs

Size: 78 in x 112 in x 100 in

Packing Size: 89 in x 44 in x 20 in



TM102- Squat Trainer

Weight: 390 lbs

Size: 60 in x 55 in x 101 in

Packing Size: 99 in x 44 in x 19 in



TM111- Squat Trainer

Weight: 452 lbs

Size: 73 in x 62 in x 61 in

Packing Size: 60 in x 50 in x 30 in



TM112- Abductor

Weight: 291 lbs

Size: 66 in x 54 in x 56 in

Packing Size: 574 in x 44 in x 20 in



TM113- Pull Down Trainer

Weight: 293 lbs

Size: 64 in x 47 in x 79 in

Packing Size: 68 in x 44 in x 20 in



TM114- Hack Slide

Weight: 507 lbs

Size: 88 in x 65 in x 54 in

Packing Size: 84 in x 44 in x 29 in



TM118- Hip Glute

Weight: 231 lbs

Size: 69 in x 59 in x 31 in

Packing Size: 54 in x 36 in x 22 in

# TNI SERIES



# STEEL & LEATHER CUSTOMIZATION

## STEEL COLOR OPTIONS

\*There may be color difference

\*For customized color, please contact with your sales manager



MATTE BLACK



GLOSS DARK  
BLUE



SAND BLACK



PEARL BLACK



SILVER GREY

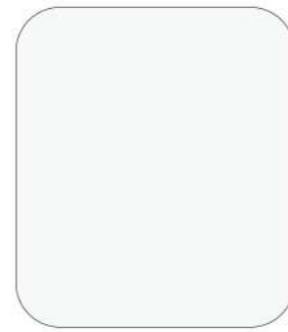

WHITE



YELLOW



ORANGE



RED

## LEATHER COLOR OPTIONS



B6



B10



B3



B1



B6



B2



B16

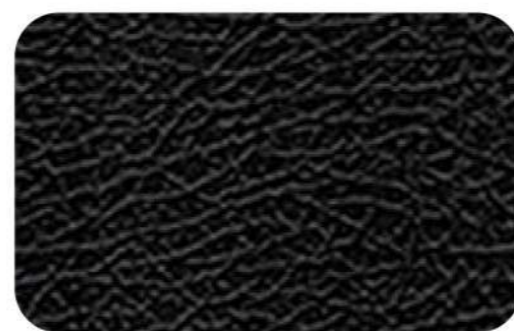

B17

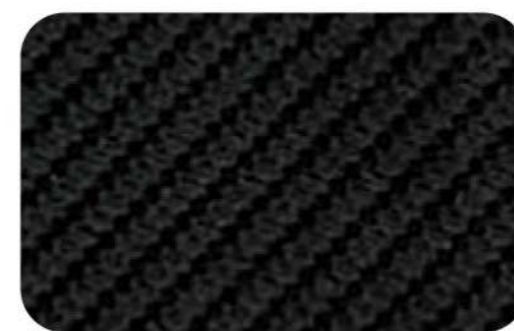

B12



B3



TN01- Incline Chest Press

Weight: 328 lbs

Size: 63 in x 39 in x 77 in

Packing Size: 64 in x 44 in x 22 in

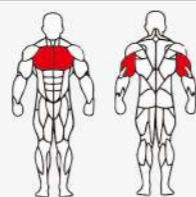

TN02- Rowing Lat Pull Down

Weight: 353 lbs

Size: 63 in x 63 in x 80 in

Packing Size: 64 in x 44 in x 22 in

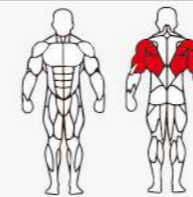

TN04- Seated Chest Press

Weight: 353 lbs

Size: 76 in x 51 in x 74 in

Packing Size: 64 in x 44 in x 22 in

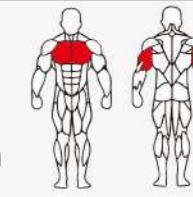

TN05- Seated Chest Press & Lat Pull Down

Weight: 423 lbs

Size: 85 in x 67 in x 80 in

Packing Size: 83 in x 45 in x 22 in

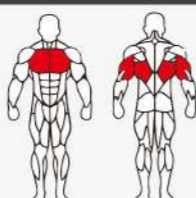

TN04- Iso Lateral Row

Weight: 282 lbs

Size: 59 in x 57 in x 54 in

Packing Size: 64 in x 44 in x 22 in

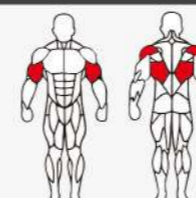

TN07- Wide Chest Press

Weight: 355 lbs

Size: 48 in x 80 in x 72 in

Packing Size: 74 in x 46 in x 24 in

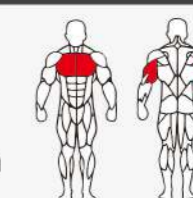



TN08- Squat Lunge

Weight: 198 lbs

Size: 54 in x 68 in x 35 in

Packing Size: 58 in x 40 in x 42 in

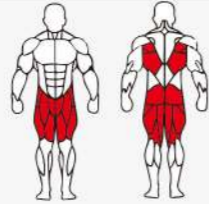

TN09- Smith Machine

Weight: 412 lbs

Size: 88 in x 50 in x 90 in

Packing Size: 91 in x 52 in x 19 in



TN13- Seated Dumbbell Row

Weight: 353 lbs

Size: 58 in x 64 in x 84 in

Packing Size: 74 in x 54 in x 20 in

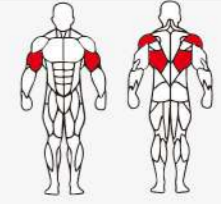

TN14- Weight Plate Tree

Weight: 423 lbs

Size: 85 in x 67 in x 80 in

Packing Size: 83 in x 45 in x 22 in



TN15- Seated Incline Chest Press

Weight: 66 lbs

Size: 30 in x 25 in x 45 in

Packing Size: 44 in x 32 in x 9 in

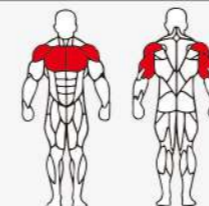

TN16- Front Lat Pulldown

Weight: 342 lbs

Size: 76 in x 60 in x 80 in

Packing Size: 78 in x 44 in x 19 in



TN18- Horizontal Leg Curl

Weight: 238 lbs

Size: 64 in x 53 in x 40 in

Packing Size: 56 in x 40 in x 27 in

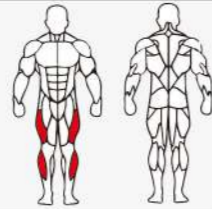

TN20- Arm Curl

Weight: 174 lbs

Size: 45 in x 32 in x 42 in

Packing Size: 54 in x 30 in x 16 in

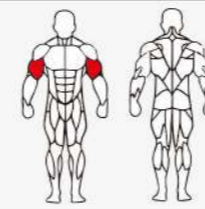

TN21- Shoulder Press

Weight: 331 lbs

Size: 73 in x 57 in x 76 in

Packing Size: 64 in x 44 in x 21 in

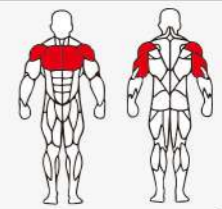

TN22- Squat Lunge

Weight: 203 lbs

Size: 69 in x 65 in x 42 in

Packing Size: 58 in x 40 in x 22 in

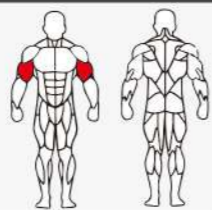

TN23- Seated Calf Machine

Weight: 152 lbs

Size: 30 in x 50 in x 33 in

Packing Size: 54 in x 30 in x 16 in

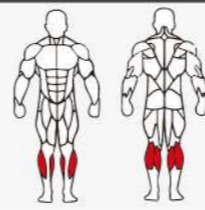

TN24- Shoulder Press

Weight: 287 lbs

Size: 57 in x 74 in x 62 in

Packing Size: 63 in x 41 in x 20 in







TN25- Low Row

Weight: 293 lbs

Size: 55 in x 54 in x 67 in

Packing Size: 64 in x 44 in x 22 in

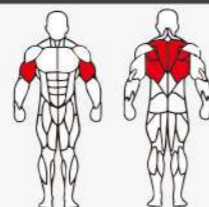

TN26- Seated Chest Press

Weight: 344 lbs

Size: 51 in x 75 in x 73 in

Packing Size: 68 in x 44 in x 22 in

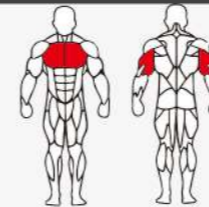

TN27- Wide Pulldown

Weight: 324 lbs

Size: 69 in x 49 in x 81 in

Packing Size: 64 in x 44 in x 22 in

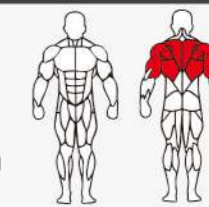

TN28- Laydown Chest Press

Weight: 216 lbs

Size: 70 in x 70 in x 43 in

Packing Size: 64 in x 44 in x 22 in

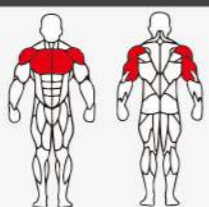

TN29- Seated Biceps

Weight: 234 lbs

Size: 54 in x 59 in x 60 in

Packing Size: 56 in x 44 in x 20 in

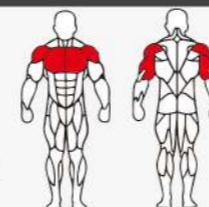

TN31- Olympic Super Rack

Weight: 249 lbs

Size: 71 in x 70 in x 73 in

Packing Size: 72 in x 36 in x 15 in



TN34- Flat Bench

Weight: 49 lbs

Size: 51 in x 20 in x 17 in

Packing Size: 53 in x 15 in x 12 in



TN38- Flat Olympic Bench

Weight: 190 lbs

Size: 66 in x 74 in x 51 in

Packing Size: 54 in x 30 in x 16 in

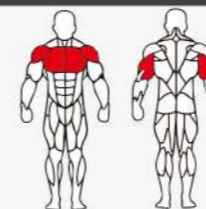

TN39- 90 Degree Leg Press

Weight: 320 lbs

Size: 50 in x 66 in x 72 in

Packing Size: 79 in x 50 in x 17 in

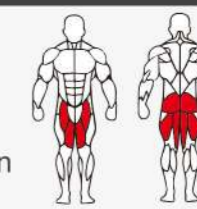

TN42- Incline Olympic Bench

Weight: 205 lbs

Size: 65 in x 74 in x 61 in

Packing Size: 66 in x 32 in x 20 in

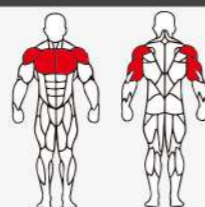

TN44- Chin Up/ Dip & Knee Up

Weight: 220 lbs

Size: 44 in x 46 in x 93 in

Packing Size: 95 in x 46 in x 20 in

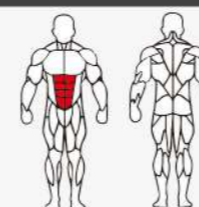

TN45- Adjustable Abdominal

Weight: 99 lbs

Size: 60 in x 27 in x 40 in

Packing Size: 68 in x 24 in x 26 in

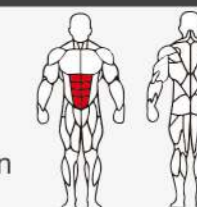



TN50- Dumbbell Rack

Weight: 132 lbs

Size: 83 in x 20 in x 31 in

Packing Size: 92 in x 12 in x 7 in



TN51- 75 Degree Incline Bench

Weight: 62 lbs

Size: 51 in x 23 in x 38 in

Packing Size: 54 in x 30 in x 17 in



TN56- Incline Pecfly

Weight: 236 lbs

Size: 64 in x 65 in x 43 in

Packing Size: 62 in x 29 in x 19 in

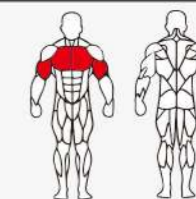

TN66- Kneeling Leg Curl

Weight: 231 lbs

Size: 66 in x 56 in x 45 in

Packing Size: 50 in x 58 in x 22 in

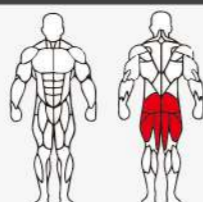

TN67- Seated Dip

Weight: 260 lbs

Size: 69 in x 62 in x 42 in

Packing Size: 74 in x 40 in x 22 in

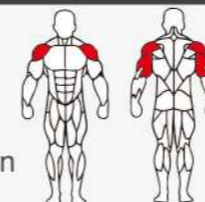

TN68- Pull Over

Weight: 331 lbs

Size: 66 in x 76 in x 66 in

Packing Size: 62 in x 52 in x 22 in





TN71- V Squat

Weight: 463 lbs

Size: 87 in x 51 in x 72 in

Packing Size: 74 in x 40 in x 30 in

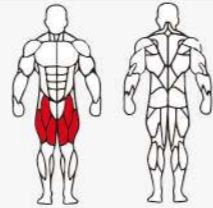

TN72- Abdominal

Weight: 287 lbs

Size: 46 in x 54 in x 60 in

Packing Size: 54 in x 44 in x 24 in

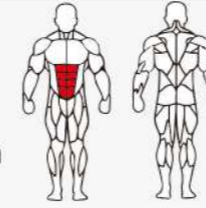

TN73- Decline Bench

Weight: 198 lbs

Size: 85 in x 74 in x 51 in

Packing Size: 58 in x 40 in x 20 in

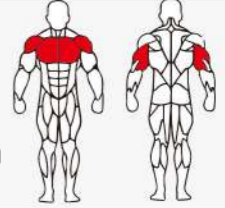

TN87- Adjustable Bench

Weight: 99 lbs

Size: 56 in x 27 in x 18 in

Packing Size: 54 in x 18 in x 13 in



TN89-Roman Chair

Weight: 130 lbs

Size: 61 in x 30 in x 32 in

Packing Size: 48 in x 28 in x 20 in

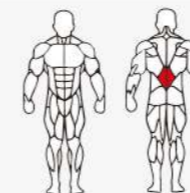

TN91- 45 Degree Leg Press

Weight: 573 lbs

Size: 94 in x 63 in x 58 in

Packing Size: 89 in x 44 in x 33 in

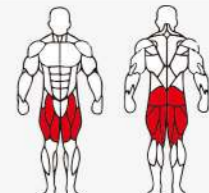



TN92- Abdominal

Weight: 95 lbs

Size: 44 in x 22 in x 20 in

Packing Size: 42 in x 24 in x 16 in



TN96- Barbell Rack

Weight: 216 lbs

Size: 39 in x 30 in x 60 in

Packing Size: 66 in x 44 in x 11 in



TN114- Hack Slide

Weight: 507 lbs

Size: 88 in x 65 in x 54 in

Packing Size: 84 in x 44 in x 29 in



TN115- Delts Machine

Weight: 249 lbs

Size: 69 in x 37 in x 66 in

Packing Size: 72 in x 44 in x 22 in



TN16- Smith Machine

Weight: 595 lbs

Size: 88 in x 53 in x 90 in

Packing Size: 95 in x 56 in x 19 in



TN117- Glute Machine

Weight: 238 lbs

Size: 47 in x 78 in x 17 in

Packing Size: 79 in x 43 in x 22 in

# SYNERGY SERIES



# STEEL & LEATHER CUSTOMIZATION

## STEEL COLOR OPTIONS

\*There may be color difference

\*For customized color, please contact with your sales manager



MATTE BLACK



GLOSS DARK  
BLUE



SAND BLACK



PEARL BLACK



SILVER GREY

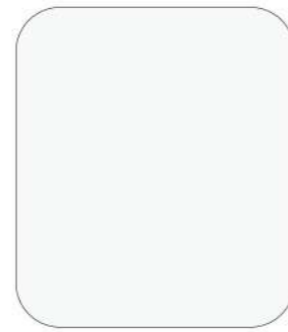

WHITE



YELLOW



ORANGE



RED

## LEATHER COLOR OPTIONS



B6



B10



B3



B1

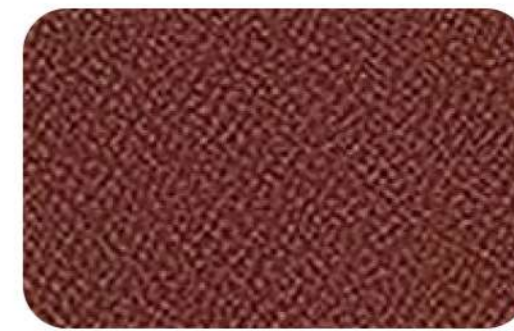

B6



B2

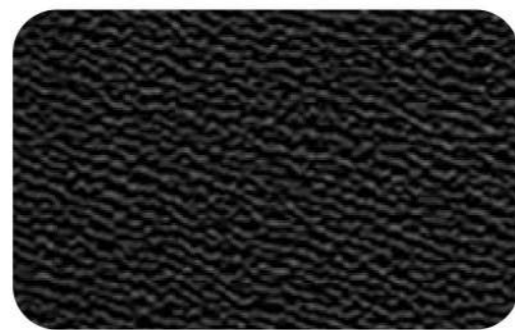

B16

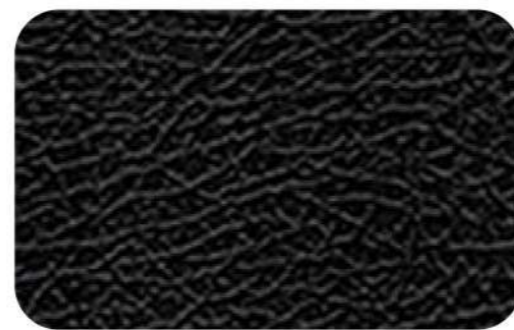

B17

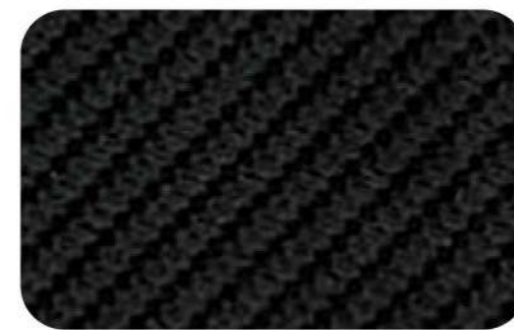

B12



B3



**TB64- Multi Jungle (8 Station)**

Weight: 2888 lbs  
 Size: 202 in x 179 in x 92 in  
 Packing Size: 109 in x 48 in x 38 in  
 Weight Stack: 176 lbs x 4 / 220 lbs x 2 / 238 lbs x 2



**TB66- Multi Jungle (4 Station)**

Weight: 1808 lbs  
 Size: 106 in x 98 in x 106 in  
 Packing Size: 95 in x 44 in x 33 in  
 Weight Stack: 176 lbs x 1 / 220 lbs x 3



**TB82- Multi Jungle (5 Station)**

Weight: 2006 lbs  
 Size: 181 in x 179 in x 92 in  
 Packing Size: 106 in x 44 in x 30 in  
 Weight Stack: 176 lbs x 3 / 220 lbs x 2



**TB90- Multi Jungle (8 Station)**

Weight: 1350kg  
 Size: 5670x3690x2275mm  
 Packing Size: 2370x1120x1250mm  
 Weight Stack: 80kg x 4 / 100kg x 4



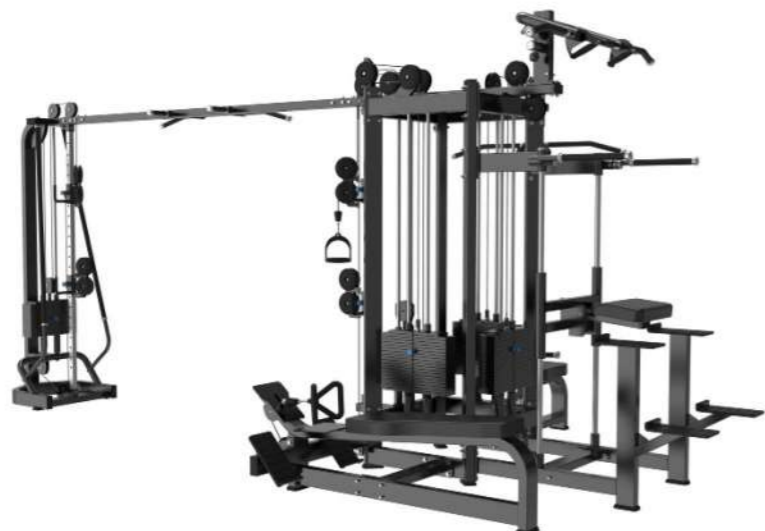

**TB94- Multi Jungle (5 Station)**

Weight: 2976 lbs  
 Size: 220 in x 106 in x 100 in  
 Packing Size: 101in x 30in x 29in/ 95in x 44in x 36in  
 Weight Stack: 176 lbs x 2 / 220 lbs x 3



**PT 360B- Synergy 360 (6 Gates)**

Weight: 1808 lbs  
 Size: 165 in x 106 in x 94 in  
 Packing Size: 93 in x 44 in x 49 in  
 Weight Stack: 176 lbs x 2



**PT360X- Synergy 360 (4 Gates)**

Weight: 1146 lbs  
 Size: 108 in x 107 in x 91 in  
 Packing Size: 93 in x 44 in x 49 in  
 Weight Stack: 176 lbs x 2



**TF40- Multi Jungle (5 Station)**

Weight: 2094 lbs  
 Size: 218 in x 108 in x 107 in  
 Packing Size: 101 in x 57 in x 19 in  
 Weight Stack: 176 lbs x 2 + 220 lbs x 3



**TF41- Multi Jungle (5 Station)**

Weight: 2174 lbs  
 Size: 185 in x 146 in x 92 in  
 Packing Size: 106 in x 44 in x 31 in  
 Weight Stack: 176 lbs x 2 + 220 lbs x 3



**TF42- Multi Jungle (8 Station)**

Weight: 2249 lbs  
 Size: 219 in x 92 in x 146 in  
 Packing Size: 93 in x 44 in x 49 in  
 Weight Stack: 176 lbs x 2 + 220 lbs x 6

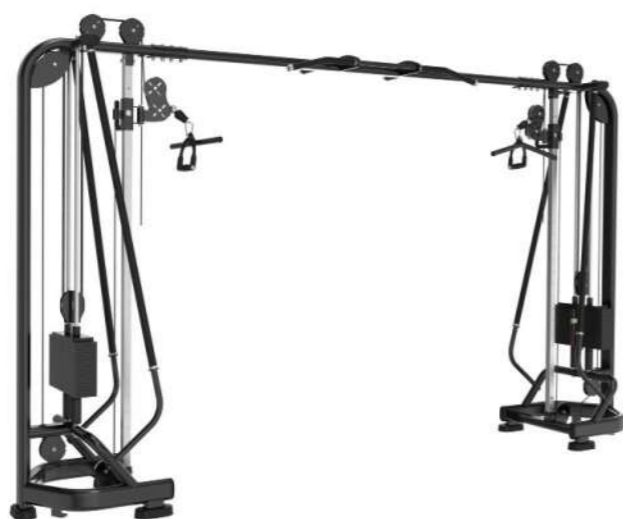

**TF21- Adjustable Crossover**

Weight: 747 lbs  
 Size: 152 in x 28 in x 92 in  
 Packing Size: 106 in x 44 in x 31 in  
 Weight Stack: 176 lbs x 2

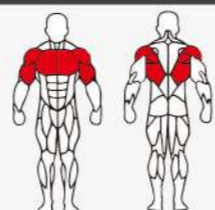

**TF23- Functional Trainer**

Weight: 750 lbs  
 Size: 76 in x 39 in x 92 in  
 Packing Size: 95 in x 44 in x 20 in  
 Weight Stack: 176 lbs x 2

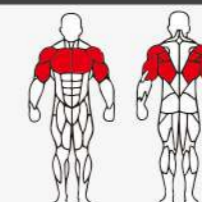

# 02 SERIES



# STEEL & LEATHER CUSTOMIZATION

## STEEL COLOR OPTIONS

\*There may be color difference

\*For customized color, please contact with your sales manager



MATTE BLACK



GLOSS DARK  
BLUE



SAND BLACK



PEARL BLACK



SILVER GREY

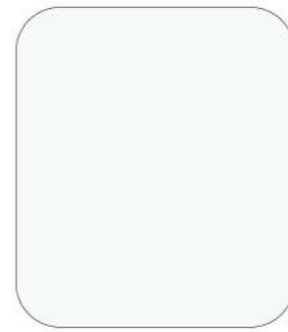

WHITE



YELLOW



ORANGE



RED

## LEATHER COLOR OPTIONS



B6



B10



B3



B1

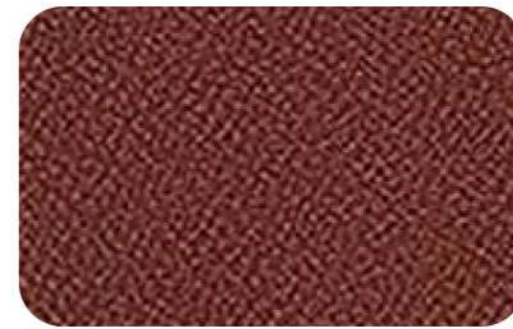

B6



B2



B16

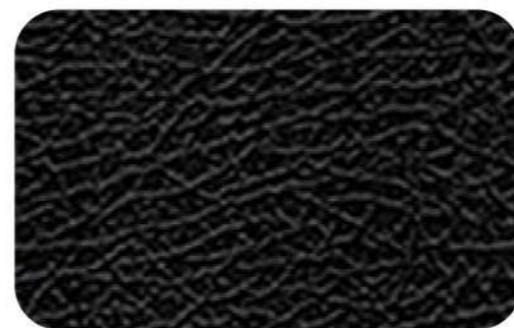

B17

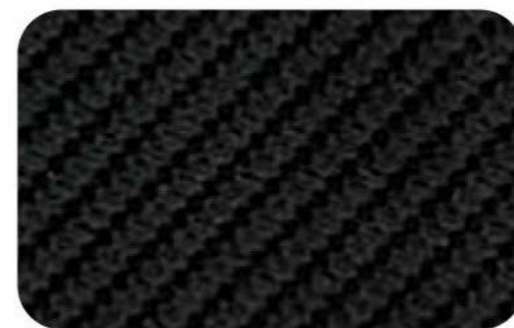

B12



B3



DZ80C- Squat Trainer

Weight: 298 lbs

Size: 86 in x 53 in x 64 in

Packing Size: 98 in x 40 in x 19 in



DZ53- Squat Trainer

Weight: 408 lbs

Size: 63 in x 65 in x 62 in

Packing Size: 69 in x 64 in x 17 in



DZ91- Pulldown

Weight: 470 lbs

Size: 68 in x 67 in x 81 in

Packing Size: 80 in x 46 in x 23 in



DZ30- Hip Glute

Weight: 187 lbs

Size: 56 in x 65 in x 31 in

Packing Size: 68 in x 44 in x 15 in



DZ97- Hip Glute

Weight: 231 lbs

Size: 87 in x 47 in x 66 in

Packing Size: 76 in x 38 in x 19 in



DZ87- Adjustable Chest Press

Weight: 419 lbs

Size: 76 in x 69 in x 72 in

Packing Size: 72 in x 38 in x 20 in



DZ31- Horizontal Roman Chair

Weight: 154 lbs

Size: 63 in x 36 in x 39 in

Packing Size: 46 in x 24 in x 20 in



DZ33- Adjustable Bench

Weight: 132 lbs

Size: 63 in x 24 in x 19 in

Packing Size: 64 in x 23 in x 20 in



DZ34- Adjustable Bench

Weight: 115 lbs

Size: 62 in x 27 in x 19 in

Packing Size: 56 in x 23 in x 17 in



DZ38- Tank Machine

Weight: 190 lbs

Size: 52 in x 33 in x 41 in

Packing Size: 48 in x 34 in x 26 in



DZ73- Multifunctional Squat Stand

Weight: 386 lbs

Size: 69 in x 68 in x 90 in

Packing Size: 89 in x 24 in x 79 in



DZ110- Standing Abductor

Weight: 269 lbs

Size: 61 in x 38 in x 57 in

Packing Size: 68 in x 44 in x 19 in



DZ92D- Multifunctional Trainer & Smith & Squat

Weight: 1433 lbs  
Size: 92.5 in x 87 in x 86.5 in  
Packing Size: 89.4 in x 61.8 in x 22 in  
Weight Stack: 176 lbs x3



DZ93- Smith Machine

Weight: 986 lbs  
Size: 86.6 in x 86.6 in x 45.3 in  
Packing Size: 89.4 in x 61.8 in x 22 in



DZ95B- Smith Machine

Weight: 1158 lbs  
Size: 92 in x 86 in x 86 in  
Packing Size: 89in x 61 in x 22 in  
Weight Stack: 132 lbs x 2



DZ102- Shoulder Press

Weight: 342 lbs  
Size: 63 in x 62 in x 58 in  
Packing Size: 64 in x 60 in x 21 in



DZ103- Incline Chest Press

Weight: 342 lbs  
Size: 79 in x 69 in x 58 in  
Packing Size: 64 in x 60 in x 21 in



DZ104- Chest Press

Weight: 342 lbs  
Size: 61 in x 62 in x 58 in  
Packing Size: 64 in x 60 in x 21 in



DZ29- Free Trainer

Weight: 406 lbs

Size: 87 in x 53 in x 64 in

Packing Size: 79 in x 44 in x 11 in



HF26- Standing Multifly

Weight: 777 lbs

Size: 59 in x 37 in x 79 in

Packing Size: 76 in x 39 in x 25 in

Weight Stack: 220 lbs



DZ82- Dual Crossover

Weight: 794 lbs

Size: 87 in x 45 in x 73 in

Packing Size: 79 in x 45 in x 26 in

Weight Stack: 176 lbs x 2



DZ51- Functional Trainer & Cross Smith

Weight: 1405 lbs

Size: 105 in x 71 in x 104 in

Packing Size: 91 in x 70 in x 20 in

Weight Stack: 176 lbs x 2



DZ89- Squat Trainer

Weight: 783 lbs

Size: 72 in x 76 in x 85 in

Packing Size: 83 in x 44 in x 19 in



DZ109- Multifunctional Trainer

Weight: 1154 lbs

Size: 104.5 in x 86.6 in x 86.4 in

Packing Size: 91 in x 68 in x 26 in





DZ76- Flat Olympic Bench

Weight: 132 lbs

Size: 61 in x 48 in x 47 in

Packing Size: 32 in x 35 in x 9 in



DZ02- Tyre Machine

Weight: 313 lbs

Size: 65 in x 49 in x 24 in

Packing Size: 56 in x 28 in x 20 in

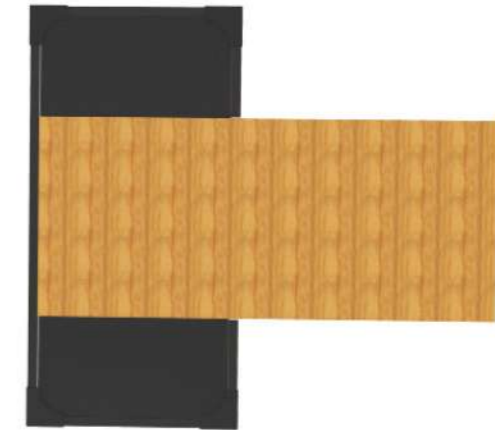

DZ18- Heavy Duty Platform

Weight: 9 lbs

Size: 83 in x 83 in x 1 in

Packing Size: 83 in x 83 in x 1 in

# CARDIO

## SERIES

# STEEL & LEATHER CUSTOMIZATION

## STEEL COLOR OPTIONS

\*There may be color difference

\*For customized color, please contact with your sales manager



MATTE BLACK



GLOSS DARK  
BLUE



SAND BLACK



PEARL BLACK



SILVER GREY

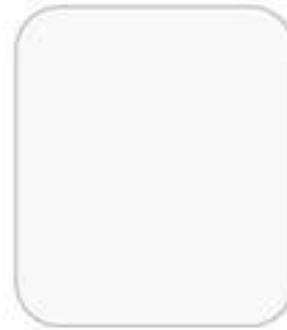

WHITE



YELLOW



ORANGE



RED

## LEATHER COLOR OPTIONS



B6



B10



B3



B1

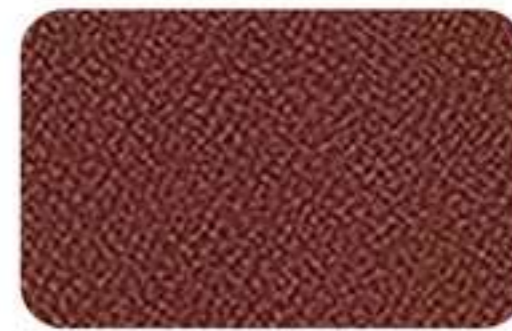

B6



B2



B16

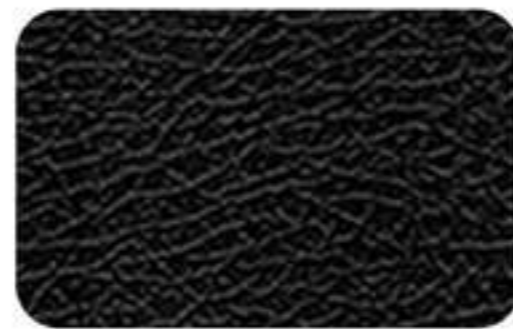

B17



B12



B3



CT910 - Commercial Treadmill

Weight - 496 lbs  
Size - 91x38x14 inches



CT920L - Commercial Treadmill LED

Weight - 492 lbs  
Size - 91x39x23 inches



CE810L - Commercial Elliptical LED

Weight - 474 lbs  
Size - 88x30x65 inches



CB610L - Commercial Upright Bike LED

Weight - 202 lbs  
Size - 60x23x45 inches



CB620L - Commercial Recumbent Bike LED

Weight - 202 lbs  
Size - 65x 18x 25 inches



CR510 - Commercial Rower

Weight - 152 lbs  
Size - 52x 24x 45 inches



LE820 - Commercial Elliptical

Weight - 383 lbs  
Size - 78 x 24 x 66 inches



CS310 - Ski Machine

Weight - 44 lbs  
Size - 48 x 22 x 19 inches



CR540 - AIR Rower

Weight - 114 lbs  
Size - 48 x 25 x 46 inches



RW530 - Water Rower

Weight - 89 lbs  
Size - 57 x 23 x 26 inches



RM520 - Residential Rower

Weight - 66 lbs  
Size - 72 x 19 x 27 inches



RC630 - Indoor Cycle

Weight - 88 lbs  
Size - 41 x 21 x 49 inches



RC610 - Indoor Cycle

Weight - 83 lbs

Size - 46 x 20 x 51 inches



RC620 - Indoor Cycle

Weight - 160 lbs

Size - 44 x 20 x 47 inches