



Save Time, Save Money



• Proven • Safe • Reliable
The original and market leading plug & play metering system

SBS easywire[®]



“ Labour savings of around 90% are achieved when compared to traditional wiring methods ”



A proven method that dramatically reduces the wiring/installation time of multifunction power meters and current transformers.

These savings are made possible due to the innovative design of both the current transformers and the meters, which allow plug in connectors to be used for both current and voltage input/output. An RJ45 lead is used for connecting between the three phase current transformer and meter, and 'ready-made' plug-in leads are used for the voltage input.

The meters are provided with both input and output voltage connections which allow up to 32 meters to be daisy chained to a common supply voltage via the first meter.



Thousands of systems now successfully working worldwide.

- Substantial labour savings
- Elimination of wiring errors
- Increased safety - Internal circuitry limits high voltages if the current transformer is disconnected under load
- No need for current transformer shorting terminals
- Proven design - successfully in service
- Simple plug-in connection for both current and voltage inputs/outputs
- Reduced testing time
- Choice of 5 three phase current transformer frame sizes
- Choice of 4 meter designs
- Less qualified installers required
- Fully EMC tested and CE certified with additional MID Certified options
- Supplied with or without cables to suit your requirements



Safer by design...

This system is safer than using traditional current transformers because **easywire**[®] transformers incorporate the resistive shunts usually located within the power meter. This means that the secondaries are always loaded, therefore eliminating the possibility of dangerously high voltages developing during open circuit conditions.

Additionally, other fitted components provide redundancy in the unlikely event that the resistor should fail.

This allows the meter to current transformer lead to be disconnected without the need for secondary shorting terminals, again saving money and reducing down time.

Panel Mounting

Connect your current transformer...

Plug one end of the RJ45 lead into the multifunction power meter and the other end into the three-phase current transformer and you're done - it's that simple.

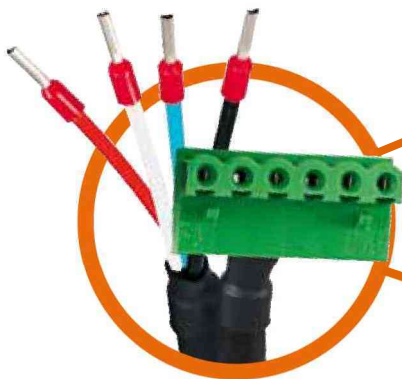
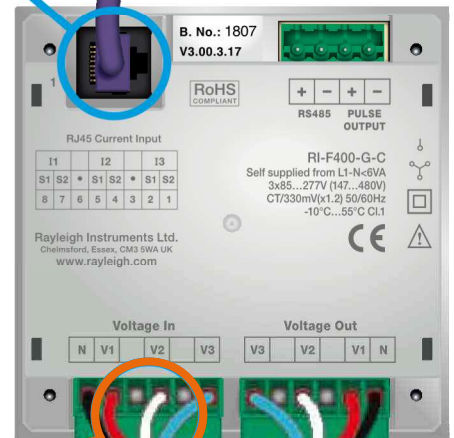
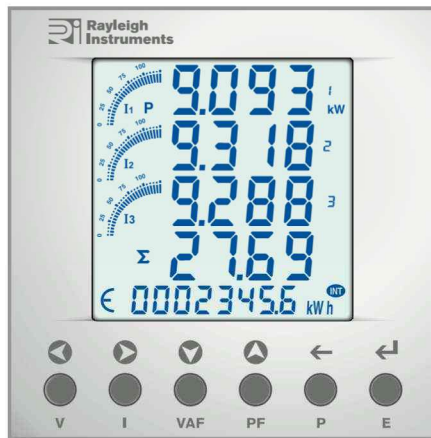
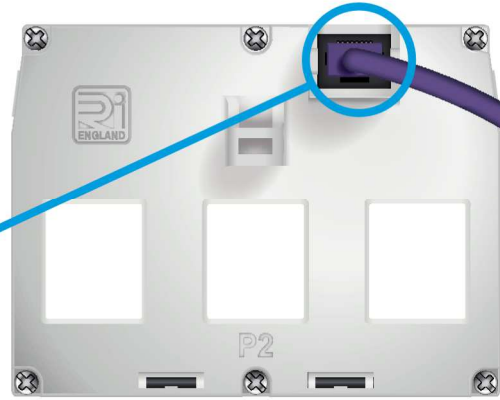
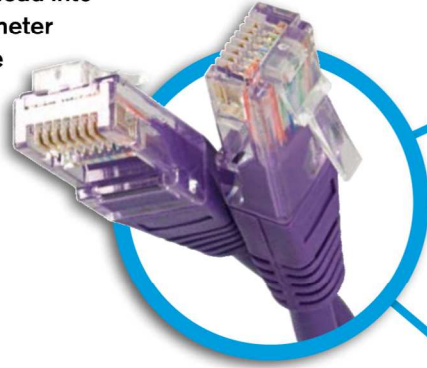

Power-up your meter...

Plug the ready-made 'supply' lead connector into your meter. Connect the other, ferrule tipped, ends to the supply, not forgetting to use the correct fuses, and you're done.

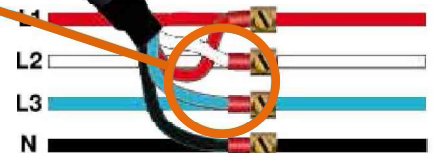
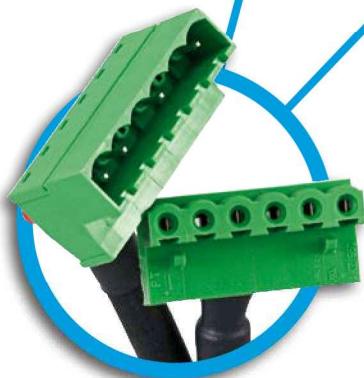
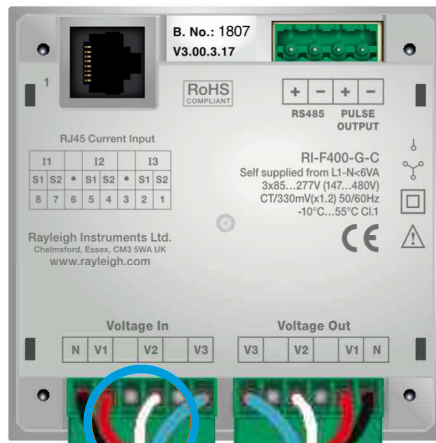
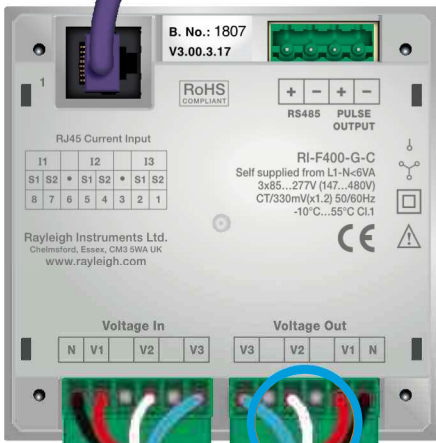

Illustration Only - device should be correctly fused.

Daisy-chain up to 32 Meters...

Power up to 32 Energy Meters from a single power source.

32



More than one meter?...

Plug the ready-made 'linking' lead connector from your first meter to your second meter.



RI-F400 & RI-F300 Panel Mounting Energy Meters



easywire® Single and Three Phase Multifunction Energy Meters

RI-F400 - Standard

- DIN 96 panel mounted
- Input from **easywire®** Current Transformers (or -/1A and -/5A CTs input with TAS-SCTEWA module)
- Single phase or three phase network compatible
- Programmable voltage and current transformer ratio
- True RMS measurement
- High definition white backlit LCD display
- Compact size - only 50mm panel depth
- Simple programming & operation
- Pulse output and Modbus communication
- Auto or manual page scrolling
- Daisy chaining up to 32 meters from one supply

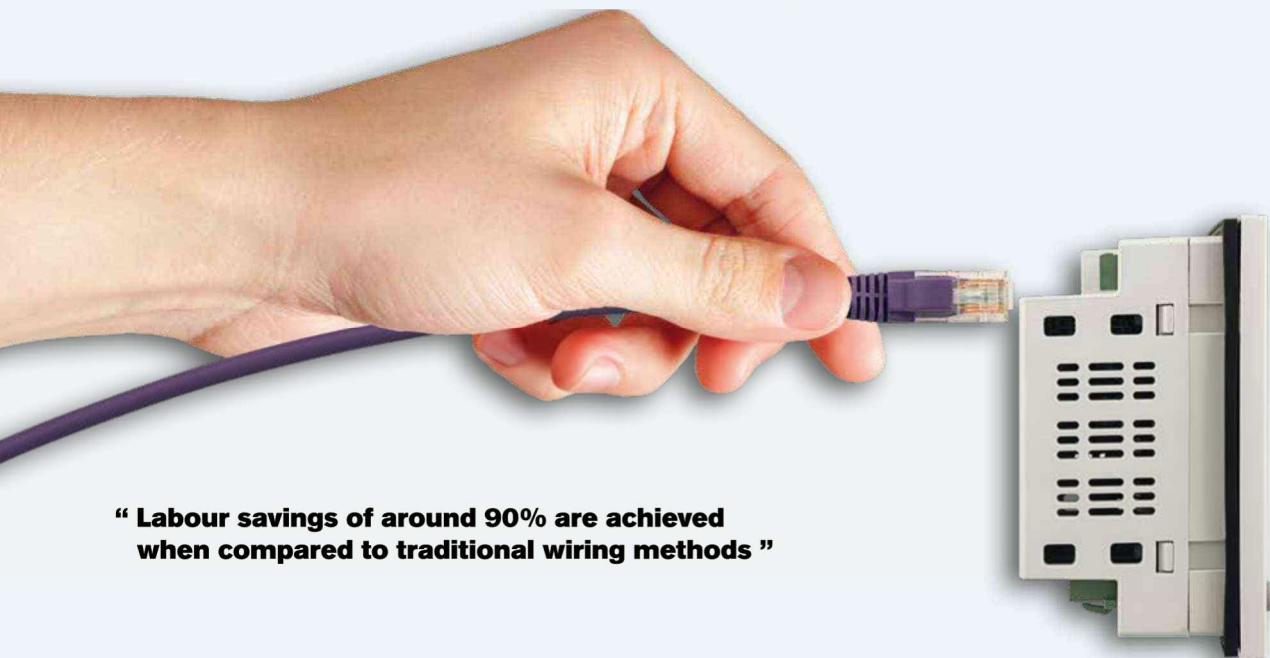

“ Labour savings of around 90% are achieved when compared to traditional wiring methods ”

The **RI-F400** and **RI-F300** (MID Certified) DIN 96 panel mounted multifunction energy meters are suitable for monitoring energy consumption and many other electrical parameters in industrial and commercial applications. These meters may be used in single or three phase applications.

A high efficiency white backlit LCD display provides clear indication of measured values in all light conditions.

Quick select push-buttons on the front of the meter allow the user fast access to the display page required.

Function Diagram

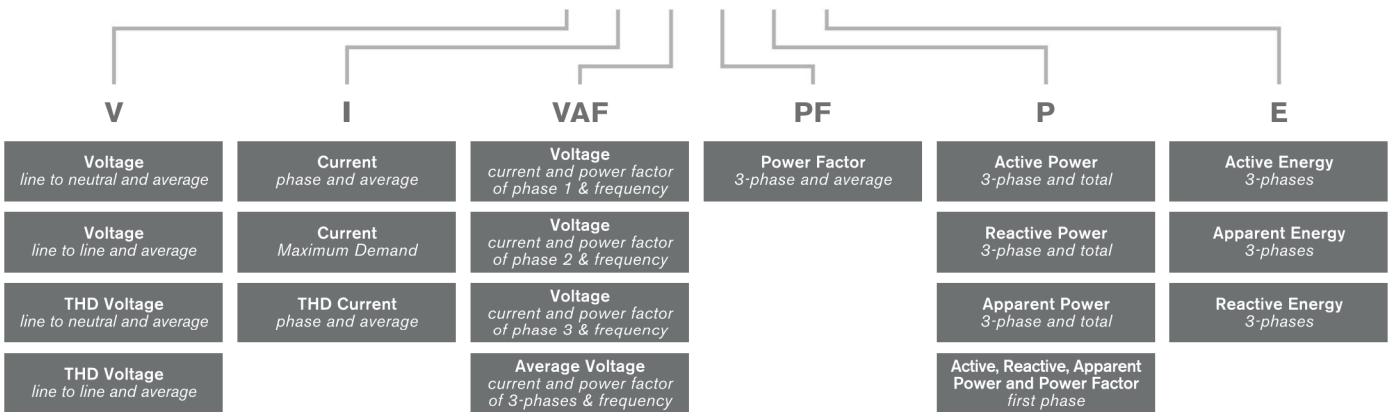
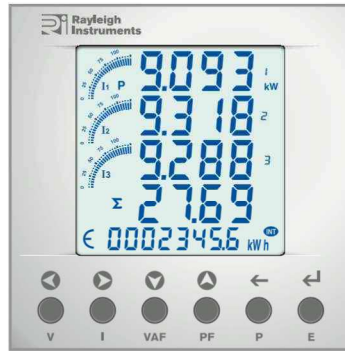

Displayed Parameters

- Voltage – L-L, L-N and average
- Current – Phase, total and Max. demand
- Power Factor – per phase and average
- Total Harmonic Distortion – Current and Voltage
- Neutral current (calculated)
- Frequency
- Hours Run – Hours & minutes
- Power – Active, Reactive and Apparent (per phase and total)
- Power Min./Max. demand – Active, reactive and apparent.
- Energy – Active, reactive and apparent (per phase and total)
- Import and export energy – Active, Reactive and Apparent (per phase and total)

Conformity

Electromagnetic compatibility	IEC/EN61326-1, IEC/EN55011 Class A, IEC/EN61000-4-2, -3, -4, -5, -6, -8, -11, IEC/EN50470-1/3
Accuracy and functionality	IEC/EN50470-1/3, IEC/EN62053-21, IEC/EN62053-23, DIRECTIVE 2014/32/EU
Safety	IEC/EN61010, IEC/EN50470-1

Dimensions (mm)

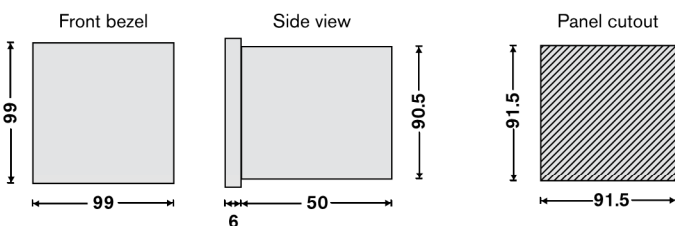

Please allow space at the rear of the meter for cable connections.

Model Selection Table

Type	Communications	Model
Standard	Pulse output	RI-F400-G-P
Standard	Modbus and pulse output	RI-F400-G-C
Standard	M-Bus and pulse output	RI-F400-G-MB
MID Certified	Modbus and pulse output	RI-F300-G-C

DIN Rail Mounting - Split Load

Two inputs into one meter...

The split load meter allows the connection of two, three phase current transformers to one meter. Typical applications include split load distribution boards.

2x

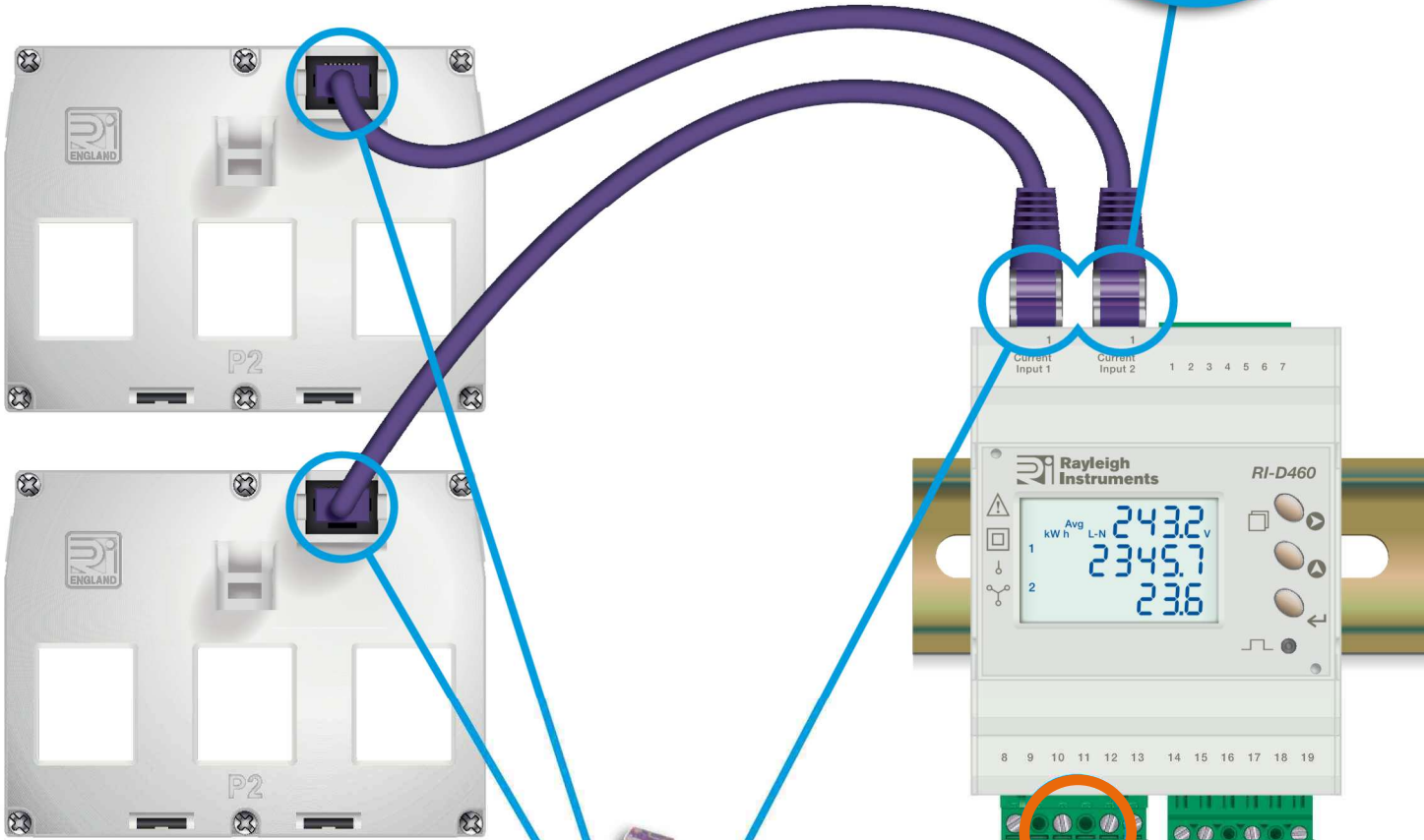

Connect your current transformer...

Plug one end of the RJ45 leads into the multifunction power meter and the other ends into the three-phase current transformers and you're done - it's that simple.

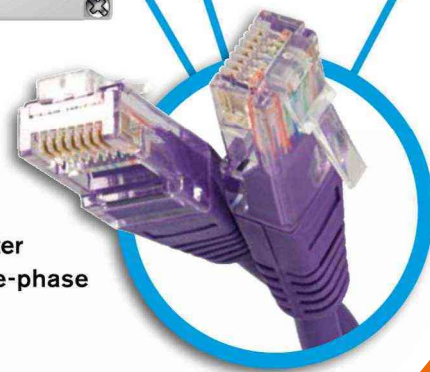

Plug to power-up your meter...

Plug the ready-made 'supply' lead connector into your meter. Connect the other, ferrule tipped, ends to the supply, not forgetting to use the correct fuses, and you're done.

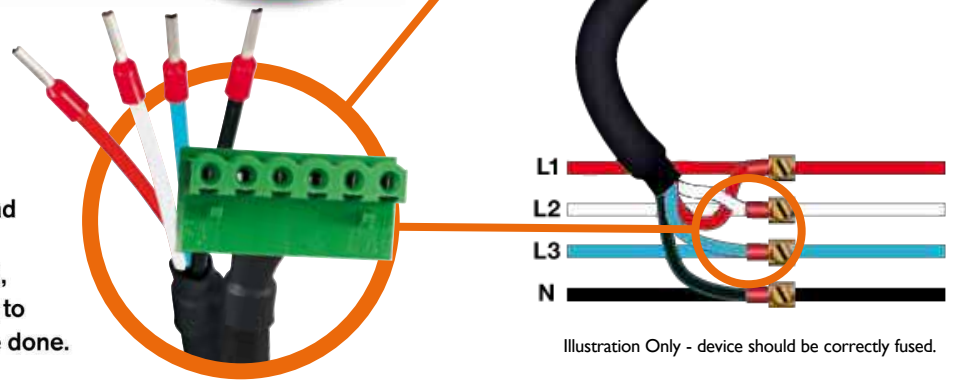
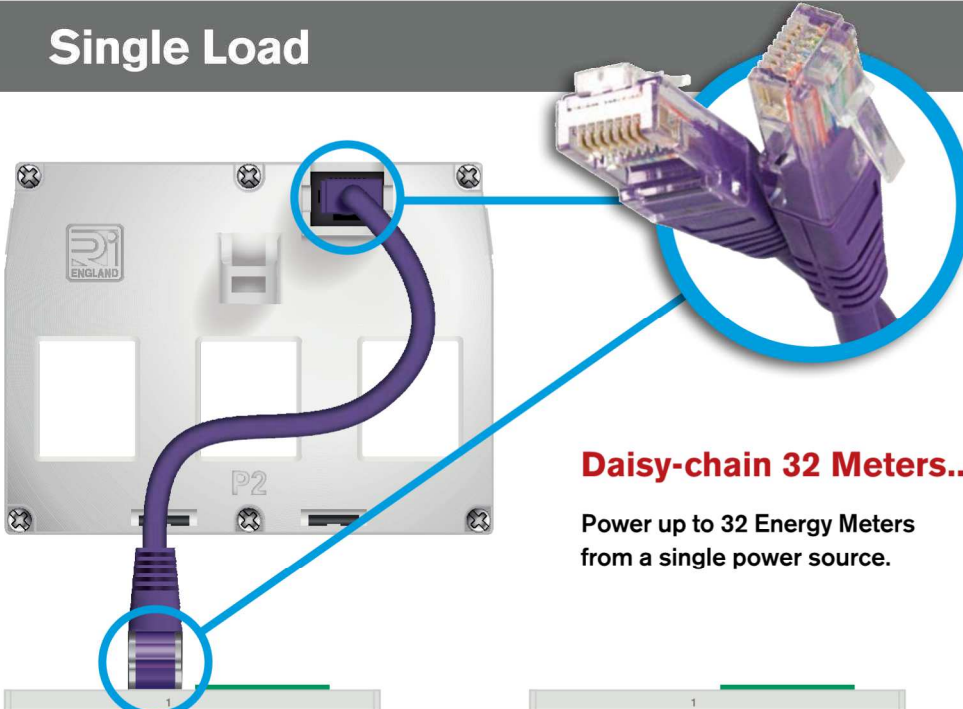

Illustration Only - device should be correctly fused.

Single Load



Connect your current transformer...

Plug one end of the RJ45 lead into the multifunction power meter and the other end into the three-phase current transformer.

Daisy-chain 32 Meters...

Power up to 32 Energy Meters from a single power source.

32



More than one meter?...

Plug the ready-made 'linking' lead connector from your first meter to your second meter.



SAVE TIME
SAVE MONEY
easywire

RI-D440 & RI-D340 DIN Rail Mounting - Single Load

Three Phase **easywire**[®] Multifunction DIN Rail Energy Meters



RI-D440 - Standard

- Four module DIN rail mounted
- Energy pulse LED
- 330mV Input from **easywire**[®] CTs (or -/1A and -/5A current transformer input with TAS-SCTEWA module)
- Single phase or three phase network compatible
- Programmable voltage and current transformer ratio
- True RMS measurement
- High definition white backlit LCD display
- Simple programming and operation
- Pulse output and Modbus communication
- Auto or manual page scrolling
- Voltage OUT connector for daisy chaining up to 32 meters from one supply

This **RI-D440** and **RI-D340** series of DIN rail mounted multifunction energy meters are suitable for monitoring energy consumption and many other electrical parameters in industrial and commercial applications.

A high efficiency white backlit LCD display provides clear indication of measured values in all light conditions.

Push-buttons on the front of the meter allow the user access to the display page required.

Displayed Parameters

Voltage - L-L, L-N and average

Current - per phase and average

Power Factor - per phase and average

Frequency

Power - Active, Reactive and Apparent (per phase and total)

Power Max. demand - Active and apparent power

Energy - Active, reactive and apparent (total)

Dimensions (mm)

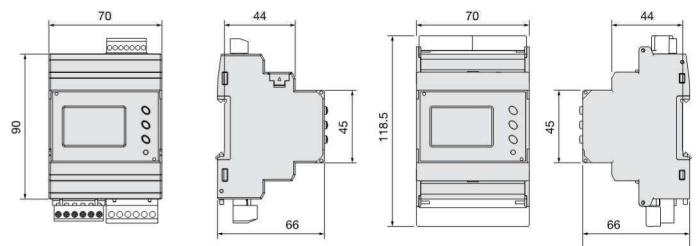

Model Selection Table

Type	Communications	Model
Standard	Single Pulse and RS485 Modbus Output	RI-D440-G-C
MID	Single Pulse and RS485 Modbus Output	RI-D340-G-C
Single Pulse and M-Bus Output versions - <i>Available soon</i>		

RI-D460 & RI-D360 DIN Rail Mounting - Dual Load



Split Load Three Phase **easywire**[®] Multifunction DIN Rail Energy Meter

RI-D460 - Standard

- Four module DIN rail mounted
- Energy pulse LED
- 2 x separate 3 Phase or 6 x Single Phase inputs (330mV) from **easywire**[®] CTs (-/5A or -/1A CTs with converter)
- Single phase or three phase network compatible
- Independently programmable CT ratios (Load 1 and Load 2)
- Programmable voltage transformer ratio
- True RMS measurement
- High definition white backlit LCD display
- Simple programming & operation / auto or manual page scrolling
- 2 x Pulse outputs and Modbus communication
- Voltage OUT connector for daisy chaining up to 32 meters from one supply

This **RI-D460** and **RI-D360** series of meters contain two metering circuits in one case, and accept inputs from two separate **easywire**[®] current transformers while still utilizing the same voltage reference.

These multifunction meters are suitable for monitoring energy consumption and many other electrical parameters in industrial and commercial applications. They are particularly suited for use in split-load lighting and power boards.

Displayed Parameters - Per Input

- Voltage - L-L, L-N and average
- Current - Per phase and average (LOAD 1 and LOAD 2)
- Power Factor - per phase and average
- Frequency
- Power - Active, Reactive and Apparent (per phase and total)
- Power Max. demand - Active and apparent power.
- Energy - Active, reactive and apparent (per load and total)

Dimensions (mm)

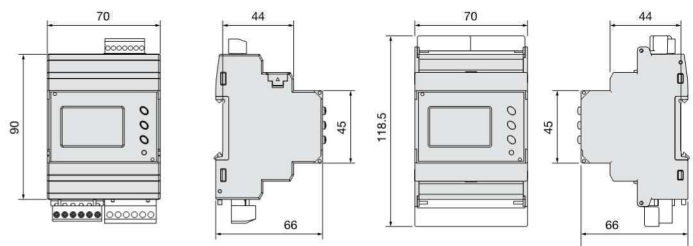

Model Selection Table

Type	Communications	Model
Standard	Split Load Input with RS485 Modbus Output and Two Pulse Outputs (1 per circuit)	RI-D460-G-C
MID	Split Load Input with RS485 Modbus Output and Two Pulse Outputs (1 per circuit)	RI-D360-G-C

M-Bus Output and Single Pulse version - **Available soon**

RI-D480 DIN Rail Mounting - Quad Load



Quad Load Three Phase **easywire**[®] Multifunction DIN Rail Energy Meter

- Four module DIN rail mounted
- Energy pulse LED
- 4 x separate 3 Phase or 12 x Single Phase inputs (330mV) from **easywire**[®] CTs (-/5A or -/1A CTs with converter)
- Single phase or three phase network compatible
- Independently programmable CT ratios (Load 1, 2, 3, 4)
- Programmable voltage transformer ratio
- True RMS measurement
- High definition white backlit LCD display
- Simple programming & operation / auto or manual page scrolling
- Modbus communication
- Voltage OUT connector for daisy chaining up to 32 meters from one supply

This **RI-D480** meters contain four metering circuits in one case, and accepts inputs from four separate **easywire**[®] three phase current transformers or 12 x single phase current transformers with **TAS-SCTEWA** adapters while still utilizing the same voltage reference.

These DIN rail mounted multifunction energy meters are suitable for monitoring energy consumption and many other electrical parameters in industrial and commercial applications. This series is particularly suited for use in multi-circuit metering boards in single or three phase applications.

A high efficiency white backlit LCD display provides clear indication of measured values in all light conditions. Push-buttons on the front of the meter allow the user access to the display page required.

A particular feature of this meter is that up to 32 x RI-D480 devices can be linked together on one Modbus system.

Each meter is provided with an input and output RJ12 Modbus ports, making 'daisy-chain' connection between devices simple.

This means that up to 128 x three phase or 384 x single phase current transformers can be connected.

Displayed Parameters

Voltage - L-L, L-N and average

Current - Per phase and average

(LOAD 1, LOAD 2, LOAD 3 and LOAD 4 or 12 x Single Phase)

Power Factor - per phase and average

Frequency

Power - Active, Reactive and Apparent (per phase and total)

Power Max. demand - Active and apparent power.

Energy - Active, reactive and apparent (per load and total)

Model Selection Table

Communications	Model
Quad Load Input with RS485 Modbus Output (RJ12 - In and Out)	RI-D480-G-C

DIN Rail Mounting - Quad Load

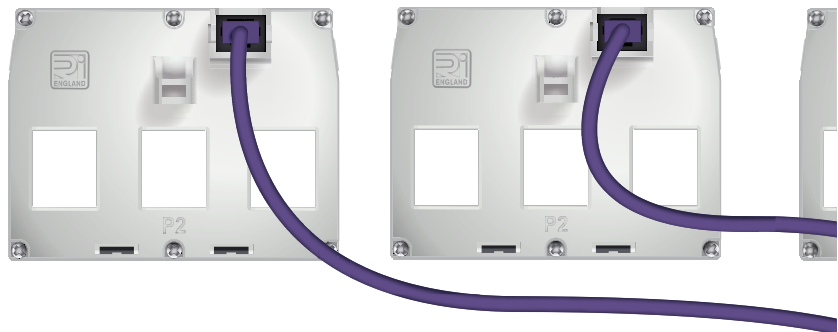

Connect 4 x 3 Phase Current Transformers to 1 x RI-D480 'QUAD' Multifunction Energy Meter.
 Daisy-chain Modbus output from up to 32 QUADs in line to 1 x Metering Display Unit.
That's 128 x 3 Phase meter loads viewable from 1 position!

Main Incomer			Light			Air Condition...			Room C25			Air Condition...			Light			Light			Light			Light			Generator		
CLOSED			CLOSED			TRIPPED			CLOSED			CLOSED			CLOSED			CLOSED			CLOSED			TRIPPED					
I1	25.1 A		I1	27.5 A		I1	19.1 A		I1	12.5 A		I1	19.1 A		I1	27.5 A		I1	27.5 A		I1	27.5 A		I1	27.5 A		I1	24.7 A	
I2	29.3 A		I2	29.7 A		I2	20.5 A		I2	21.0 A		I2	20.5 A		I2	29.7 A		I2	29.7 A		I2	29.7 A		I2	29.7 A		I2	20.9 A	
I3	18.7 A		I3	23.7 A		I3	15.4 A		I3	23.3 A		I3	15.4 A		I3	23.7 A		I3	23.7 A		I3	23.7 A		I3	23.7 A		I3	15.6 A	
V1	224 V		7174 kWh			7486 kWh			7057 kWh			7486 kWh			7174 kWh			7174 kWh			7174 kWh			7174 kWh					
V2	235 V		400 A			200 A			1500 A			125 A			125 A			125 A			125 A			125 A					
V3	225 V																												
Main Incomer			Light			Air Condition...			Room C25			Air Condition...			Light			Light			Light			Light			Generator		

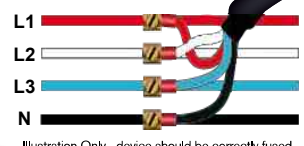
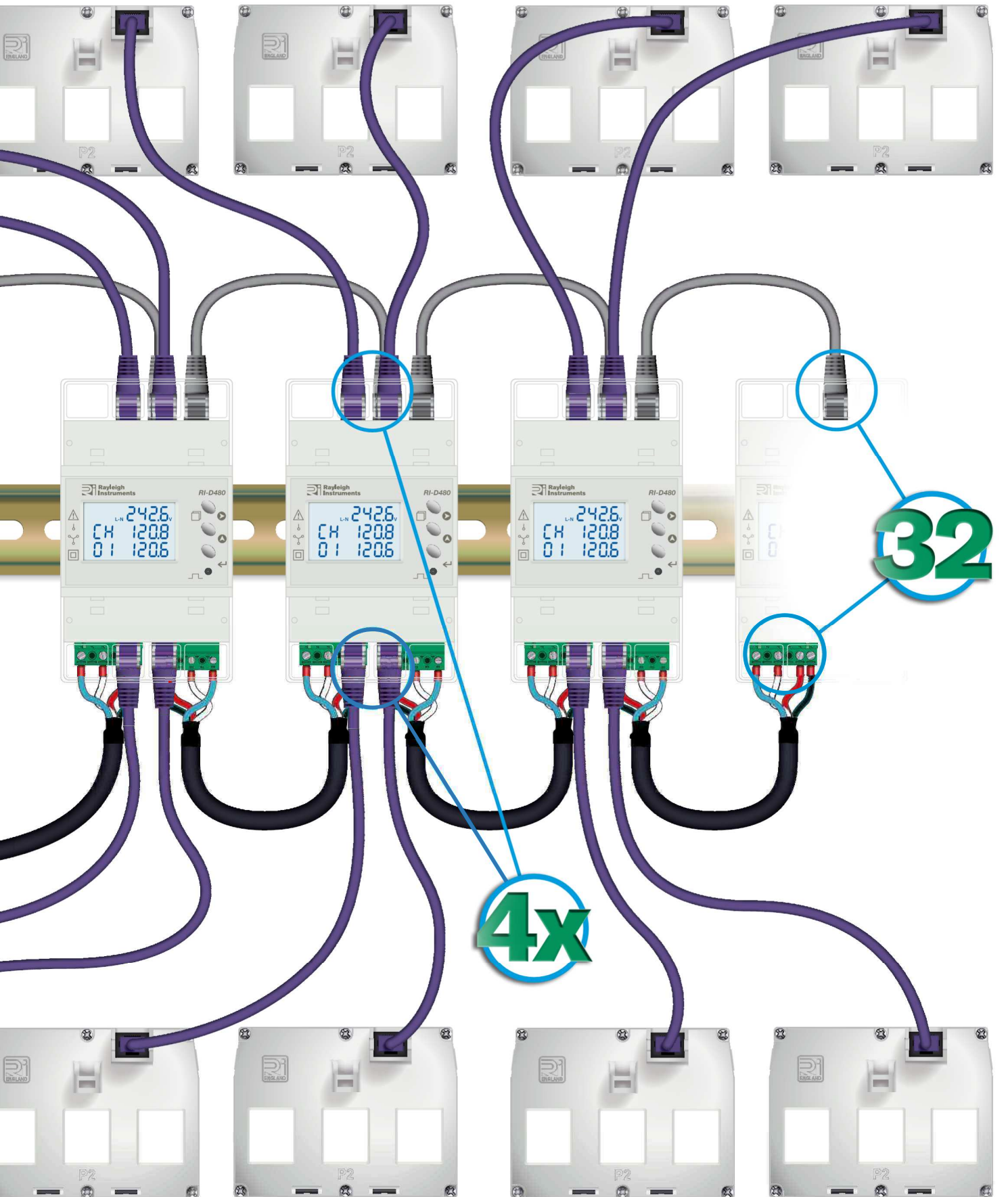

Illustration Only - device should be correctly fused.





RI-MDU10 Series

View all your meters on one device

- Reduce the size of your panel with one cut out for all the metering requirements
- Reduce labour costs using Rayleigh **easywire**[®] plug and play technologies
- Increase safety, only 24 VDC on door
- Available in 7 and 10 inch screens
- High resolution full colour touch display
- View up to 128 three phase meters or 384 single phase meters on one Meter Display Unit(MDU)
- Monitor breaker status - Tripped/ on / off with data logging
- One month of historic data can be viewed from meter display unit, permanent data logging when connected to **rayleighconnect**[™] cloud system
- Simple intuitive programming and navigation through the MDU display
- 2 x independent RS485 Modbus output



The **RI-MDU10** series is a Metering Display Unit designed to compliment our **rayleighconnect**[™] system for the control and monitoring of local or remote devices.

EXPLANATION OF TOPOLOGY

The RI-MDU10 gets data from meters through Ethernet slave devices which function as Modbus masters (RI-EX20). The Ethernet port on RI-MDU10 functions as a network router and has DHCP enabled. All traffic on the Ethernet network is encrypted.

The MDU10 has two additional network outputs either 2 x RS485 or a combination of 1 x RS485 and 1 x RS232 self configured.

This enables the user to send data simultaneously to two software systems, for example 1 building management system and the other to a energy/billing platform like **rayleighconnect**[™].

Additional Features

Built in web browser allowing remote monitoring and control from anywhere in the world.

Historical data can be displayed via graphs, charts or exported via CSV.

On board storage for switchgear maintenance records and design drawing.

Create alarm function via either text message or email if connected to rayleighconnect[™] cloud system.

Model Selection Table

Description	Model
i.MX6Quad Processor, 1Gb DDR3 Memory, 16Gb Storage, 24V Power. I/O expansion - TXB-I2-GS2-GG8 (Galvanic Isolated 2x RS-232 + 2x CAN + 8x GPIO, RS485	RI-MDU10

You can even use standard CT's...



Connect your easywire® power meter...

Plug one end of the RJ45 lead into the multifunction power meter and the other end into the converter.

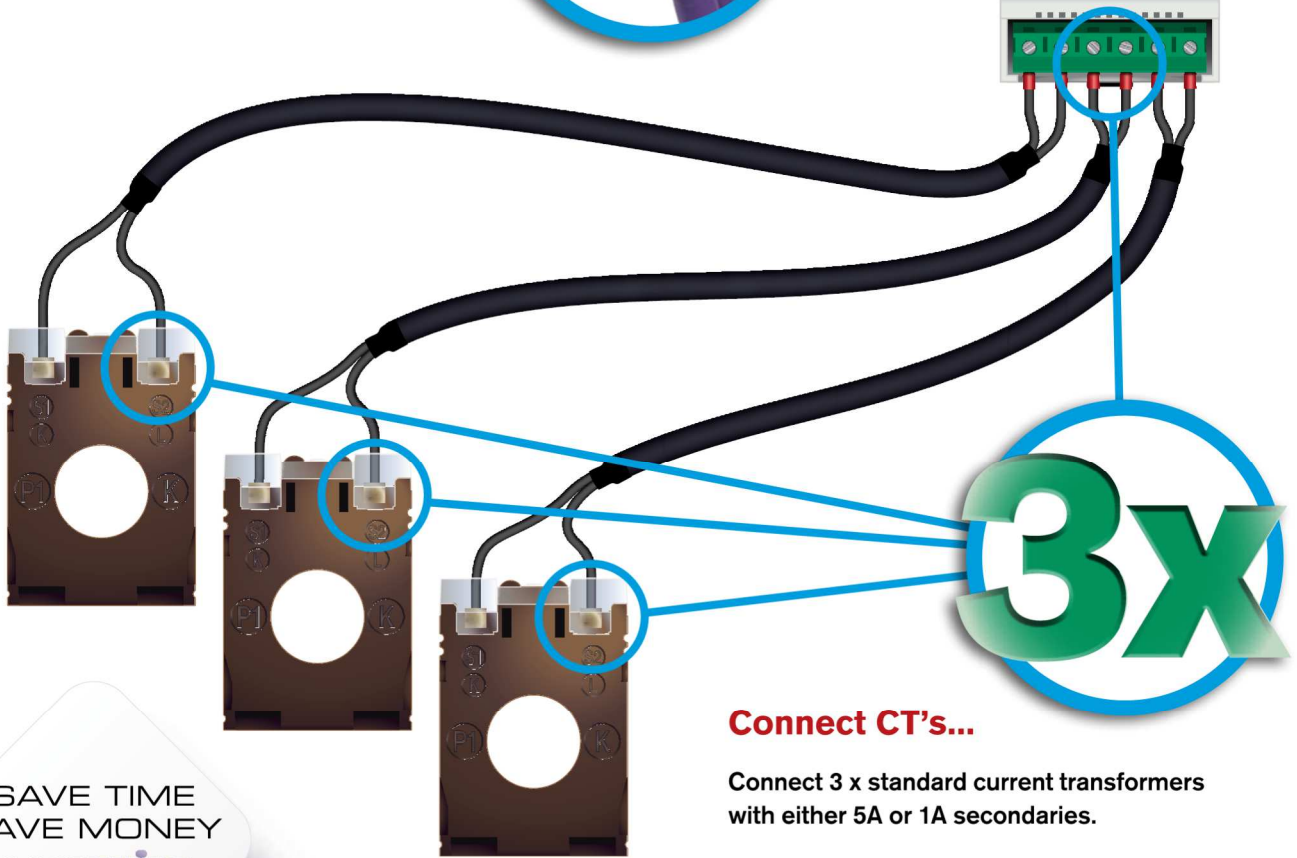
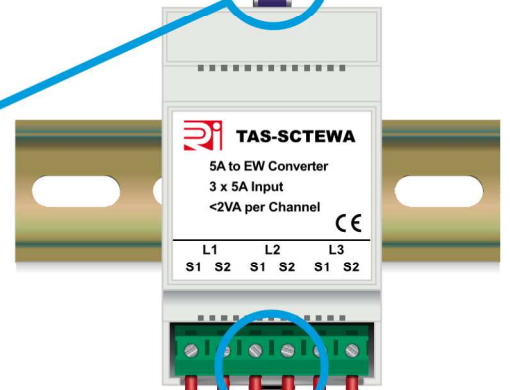

Connect CT's...

Connect 3 x standard current transformers with either 5A or 1A secondaries.



TAS-SCTEWA



Standard Current Transformer to easywire® System Adaptor

- Connect up to 3 standard or split core CT's (1A or 5A secondaries)
- Integrated protection circuitry



The **TAS-SCTEWA** converter allows for the connection of up to three standard current transformers, or standard split-core current transformers (with 1A or 5A secondary's), to the Rayleigh Instruments **easywire**® system.

The unit has integrated protection circuitry allowing for disconnection from meter under load conditions for maintenance.

Important Notes

This converter does not provide electrical isolation.

Current transformer secondaries may not be earthed and should be wired as shown.

This converter is not MID certified and should not be used for billing applications.

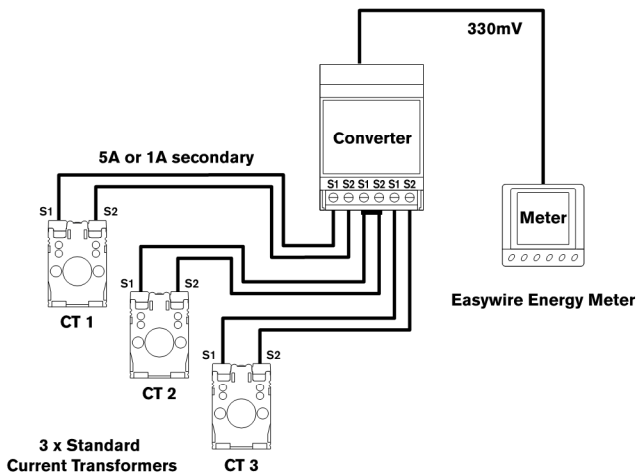

Technical Specification

Burden	2VA per channel (5A Version) <0.5VA per channel (1A Version)
Accuracy	0.4%
Suggested Cable Size	1.5...2.5mm ² (2.5mm ² Max. - CT to Adaptor)
Mounting	DIN rail 35mm
Termination	CT to adaptor - Rising clamp screw terminals Adaptor to Meter - RJ45 Patch Cable
Operating Temperature	-10°C...+45°C
Storage Temperature	-25°C...+70°C

Dimensions (mm)

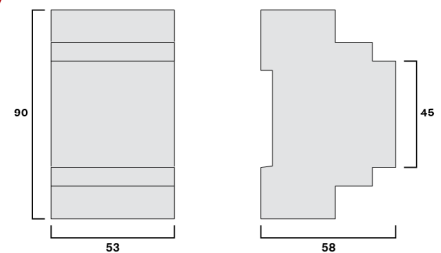

Model Selection Table

Variants	Model
-/5A Secondary (standard)	TAS-SCTEWA 5A
-/1A Secondary (available on request)	TAS-SCTEWA 1A

RI-CT240-EW Series



easywire® Three Phase Current Transformers

- Patented technology
- Foot, busbar or DIN rail mounting
- RJ45 connector output
- Safe to leave transformer on load with output disconnected
- Fits standard moulded circuit breaker frame sizes
- From 60A to 200A Primary current input available
- 330mV output
- Sealable RJ45 connection
- 76mm width
- 25mm bar centres
- 30 x 15mm apertures

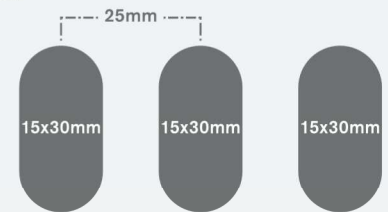

The **RI-CT240-EW** is part of the **easywire®** family of current transformers and is one of five frame sizes available.

The **easywire®** system has been designed to save up to 90% installation time compared to a standard current transformer to meter installation.

This three phase current transformer is suitable for monitoring current in industrial and commercial applications and is designed to connect to the **easywire®** series of metering products.

Built-in limiting circuitry ensures the secondary of the current transformer is always under load and clamped to a safe level. This means that the output connection may be safely disconnected while under load.

Improved design features of these **easywire®** current transformers include fixing feet, a robust 'snap-on' DIN rail fixing, captive busbar location screw fittings, insulated busbar location feet, sealable (anti-tamper) RJ45 connection sockets and moulded load direction indication arrows on the CT shoulders.

All our three phase current transformers have been designed with hole centres and apertures to fit most standard industrial circuit breakers.



Parameters

Primary Current	Output (RJ45)	Order Code
60A	330mV	060
100A	330mV	100
125A	330mV	125
150A	330mV	150
160A	330mV	160
200A	330mV	200

Dimensions (mm)

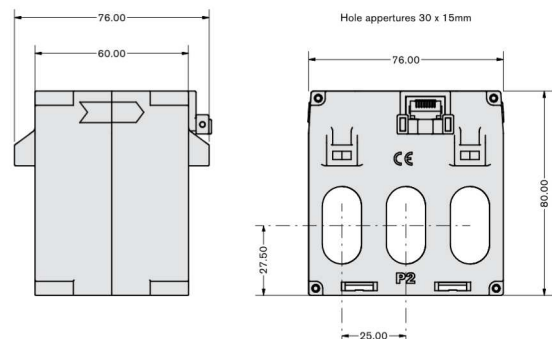

Information Required with Order

Build your order number - example	RI-CT240-EW	125
Model		
Primary Current Range - See Parameters Table 'Order Code'		

RI-CT242-EW Series



easywire® Three Phase Current Transformers

- Patented technology
- Foot, busbar or DIN rail mounting
- RJ45 connector output
- Safe to leave transformer on load with output disconnected
- Fits standard moulded circuit breaker frame sizes
- From 60A to 250A Primary current input available
- 330mV output
- Sealable RJ45 connection
- 105mm width
- 35mm bar centres
- 25 x 21mm apertures

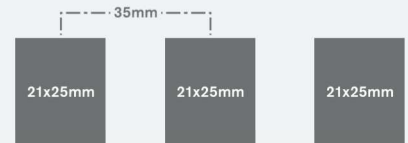

The **RI-CT242-EW** three phase current transformer is suitable for monitoring current in industrial and commercial applications and is designed to connect to the **easywire®** series of metering products.

Built-in limiting circuitry ensures the secondary of the current transformer is always under load and clamped to a safe level. This means that the output connection may be safely disconnected while under load.

Improved design features of these **easywire®** current transformers include fixing feet, a robust 'snap-on' DIN rail fixing, captive busbar location screw fittings, insulated busbar location feet, sealable (anti-tamper) RJ45 connection sockets and moulded load direction indication arrows on the CT shoulders.



Options

The **RI-CT242-EW** is available with a horizontal RJ45 socket (stock) or a vertical RJ45 socket (to order).



Parameters

Primary Current	Output (RJ45)	Order Code
60A	330mV	060
100A	330mV	100
125A	330mV	125
150A	330mV	150
160A	330mV	160
200A	330mV	200
250A	330mV	250

Dimensions (mm)

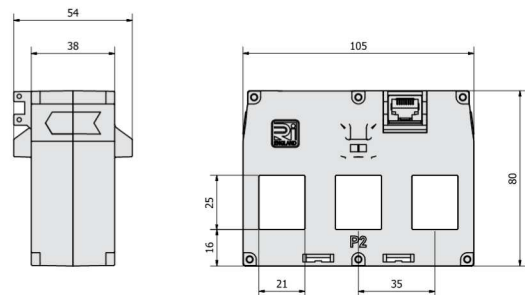

Information Required with Order

Build your order number - example	RI-CT242-EW	0160	- V
Model			
Primary Current Range - See Parameters Table 'Order Code'			
* Vertical RJ45 Option - for Vertical RJ45 connection add suffix '- V'			

* Vertical option is to order only.

RI-CT248-EW Series



easywire® Three Phase Current Transformers

- Patented technology
- Foot, busbar or DIN rail mounting
- RJ45 connector output
- Safe to leave transformer on load with output disconnected
- Fits standard moulded circuit breaker frame sizes
- From 150A to 630A Primary current input available
- 330mV output
- Sealable RJ45 connection
- 140mm width
- 45mm bar centres
- 31 x 31mm apertures



The **RI-CT248-EW** three phase current transformer is suitable for monitoring current in industrial and commercial applications and is designed to connect to the **easywire®** series of metering products.

Built-in limiting circuitry ensures the secondary of the current transformer is always under load and clamped to a safe level. This means that the output connection may be safely disconnected while under load.

Improved design features of these **easywire®** current transformers include fixing feet, a robust 'snap-on' DIN rail fixing, captive busbar location screw fittings, insulated busbar location feet, sealable (anti-tamper) RJ45 connection sockets and moulded load direction indication arrows on the CT shoulders.



Options

The **RI-CT248-EW** is available with a horizontal RJ45 socket (stock) or a vertical RJ45 socket (to order).



Parameters

Primary Current	Output (RJ45)	Order Code
150A	330mV	0150
200A	330mV	0200
250A	330mV	0250
300A	330mV	0300
400A	330mV	0400
500A	330mV	0500
600A	330mV	0600
630A	330mV	0630

Dimensions (mm)

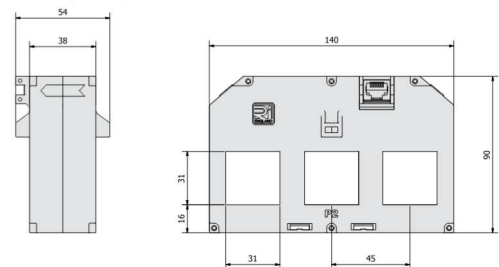

Information Required with Order

Build your order number - example	RI-CT248-EW	0400	- V
Model			
Primary Current Range - See Parameters Table 'Order Code'			

* Vertical RJ45 Option - for Vertical RJ45 connection add suffix '- V'

* Vertical option is to order only.

RI-CT249-EW Series

easywire® Three Phase Current Transformers



- Patented technology
- Foot, busbar or DIN rail mounting
- RJ45 connector output
- Safe to leave transformer on load with output disconnected
- Fits standard moulded circuit breaker frame sizes
- From 60A to 160A Primary current input available
- 330mV output
- Sealable RJ45 connection
- 90mm width
- 29mm bar centres
- 20 x 16mm apertures

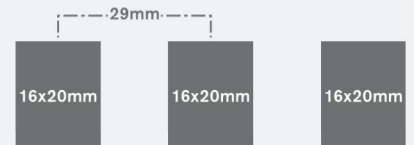

The **RI-CT249-EW** three phase current transformer is suitable for monitoring current in industrial and commercial applications and is designed to connect to the **easywire®** series of metering products.

Built-in limiting circuitry ensures the secondary of the current transformer is always under load and clamped to a safe level. This means that the output connection may be safely disconnected while under load.

Improved design features of these **easywire®** current transformers include fixing feet, a robust 'snap-on' DIN rail fixing, captive busbar location screw fittings, insulated busbar location feet, sealable (anti-tamper) RJ45 connection sockets and moulded load direction indication arrows on the CT shoulders.



Parameters

Primary Current	Output (RJ45)	Order Code
60A	330mV	060
100A	330mV	100
125A	330mV	125
150A	330mV	150
160A	330mV	160

Dimensions (mm)

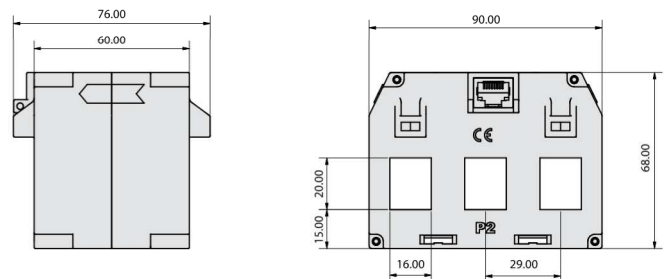

Information Required with Order

Build your order number - example	RI-CT249-EW 150
Model	
Primary Current Range - See Parameters Table 'Order Code'	

RI-CT250-EW Series



easywire® Three Phase Current Transformers

- Patented technology
- Foot, busbar or DIN rail mounting
- RJ45 connector output
- Safe to leave transformer on load with output disconnected
- Fits standard moulded circuit breaker frame sizes
- From 800A to 1600A Primary current input available
- 330mV output
- Sealable RJ45 connection
- 215mm width
- 70mm bar centres
- 50 x 54mm apertures



The **RI-CT250-EW** three phase current transformer is suitable for monitoring current in industrial and commercial applications and is designed to connect to the **easywire®** series of metering products.

Built-in limiting circuitry ensures the secondary of the current transformer is always under load and clamped to a safe level. This means that the output connection may be safely disconnected while under load.

Improved design features of these **easywire®** current transformers include fixing feet, a robust 'snap-on' DIN rail fixing, captive busbar location screw fittings, insulated busbar location feet, sealable (anti-tamper) RJ45 connection sockets and moulded load direction indication arrows on the CT shoulders.



Options

The **RI-CT250-EW** is available with a horizontal RJ45 socket (stock) or a vertical RJ45 socket (to order).



Parameters

Primary Current	Output (RJ45)	Order Code
800A	330mV	0800
1000A	330mV	1000
1200A	330mV	1200
1250A	330mV	1250
1500A	330mV	1500
1600A	330mV	1600

Dimensions (mm)

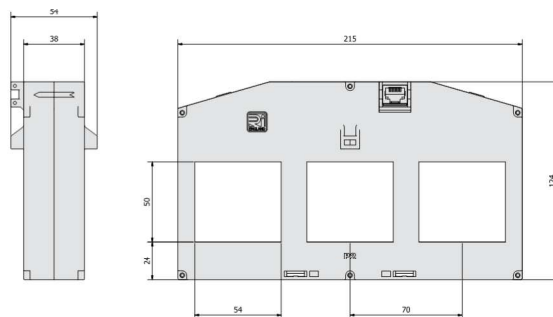

Information Required with Order

Build your order number - example	RI-CT250-EW	0800	- V
Model			
Primary Current Range - See Parameters Table 'Order Code'			

* Vertical RJ45 Option - for Vertical RJ45 connection add suffix '- V'
 * Vertical option is to order only.

Essential Extras and Accessories

CT Output and RJ45 Lead Tester

This device makes it possible to test the RJ45 patch lead used to connect the current transformer to the meter. It also enables a standard electricians multimeter to measure the individual secondary outputs of the current transformer.

To test the RJ45 patch lead, simply disconnect the lead from the meter and current transformer. Plug one end into socket ① and the other end into socket ② on the test box. Press the test button - the Green LED will light to indicate the lead is OK or the Red LED will light to indicate a faulty lead.

When the lead is proven to be OK you can then check the individual secondary outputs of the current transformer.

To measure the secondary output plug one end of the RJ45 patch lead into the current transformer and the other end into socket ② on the test box. You can now use a standard multimeter to test the secondaries using the test points on the front of the test box.

The output measured for each phase should be between 0 and 330mVac.

Model Reference: **TAS-EWTEST**



3 Phase CT Splitter Box

This 3 Phase CT Splitter Box allows the separate monitoring of each phase of a three phase current transformer on individual energy meters.

Model Reference: **TAS-3RSB**

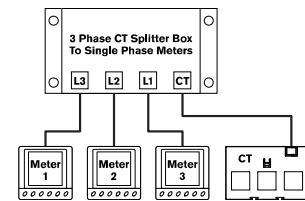

Meter Voltage Supply Cable

Our high quality Meter Voltage Supply Cables are fitted with a plug at one end and insulated bootlace ferrules at the other and provide power to the **easywire**® meter from your mains supply.



How to Order / Model Reference

PVC/PVC - 1mm²

eg **TAS-F-MVSC** 0.30

Part Number	TAS-F-MVSC	
Cable Length PVC/PVC		
0.3m - Voltage Supply Cable (300mm)		0.30
0.5m - Voltage Supply Cable (500mm)		0.50
1.0m - Voltage Supply Cable (1000mm)		1.00
1.3m - Voltage Supply Cable (1300mm)		1.30
2.0m - Voltage Supply Cable (2000mm)		2.00
3.0m - Voltage Supply Cable (3000mm)		3.00
Other lengths available on request (Max. 15m)		

Meter to Meter Supply Cable

High quality Meter to Meter Voltage Supply Cables are fitted with a plug at one end and socket at the other; allowing multiple **easywire**® meters to be powered from a common supply. Up to 32 meters can be powered in 'daisy-chain'.



How to Order / Model Reference

PVC/PVC - 1mm²

eg **TAS-F-MTMSC** 0.30

Part Number	TAS-MTMSC	
Cable Length		
0.15m - Supply Link Cable (150mm)		0.15
0.3m - Supply Link Cable (300mm)		0.30
0.5m - Supply Link Cable (500mm)		0.50
1.0m - Supply Link Cable (1000mm)		1.00
1.3m - Supply Link Cable (1300mm)		1.30
2.0m - Supply Link Cable (2000mm)		2.00
3.0m - Supply Link Cable (3000mm)		3.00
Other lengths available on request (Max. 15m)		

RJ45 Connection Cable

The high quality low loss Category 6 RJ45 Connection Cable provides secondary connection between the **easywire**® current transformer and meter.



How to Order / Model Reference

eg **W2750PUR**

Part Number **W27xxPUR**

Cable Length	
0.3m - RJ45 connector cable (300mm)	
0.5m - RJ45 connector cable (500mm)	
1.0m - RJ45 connector cable (1000mm)	
1.5m - RJ45 connector cable (1500mm)	
2.0m - RJ45 connector cable (2000mm)	
3.0m - RJ45 connector cable (3000mm)	
Other lengths available on request (Max. 15m)	

Supply Voltage Connector Plugs

For those who want to make up their own power cable looms, connector plugs are available.

Model Reference

Voltage IN (Male) Connector: BV9523MALE

Voltage OUT (Female) Connector: BV9522FEMALE





• **Proven** • **Safe** • **Reliable**

The original and market leading plug & play metering system



Head Office : SBS - Smart Building Services Pty Ltd

Unit 4, 59 Beattie Street

Kallangur QLD 4503 Australia

Telephone : +61 (0)7 3285 4344

email : sales@sbs.digital

Web : www.sbs.digital