



DATA SHEET

PN: 24U170CL05S/5

Metering Current Transformer

GENERAL INFORMATION

APPLICATION	: MEASUREMENT	INSIDE DIAMETER (mm)	: 170
SERIES	: 24	OUTSIDE DIAMETER (mm)	: 248
FORM	: U170	AXIAL LENGTH (mm)	: 57
CT TYPE	: TOROIDAL	HEIGHT (mm)	: 311

TERMINALS	: BRASS TUNNEL TERMINALS	MOUNTING	: ALUMINIUM BRACKET FITTED
------------------	---------------------------------	-----------------	-----------------------------------

TECHNICAL INFORMATION

STANDARD	: AS60044.1-2007	INSULATION TYPE	: EPOXY RESIN
CURRENT RATIO	: 2000/5	INSULATION LEVEL	: 3KV
CLASS	: 0.5S Ext. 200%	NOMINAL VOLTAGE	: 0.72KV
VA RATING	: 15VA	THERMAL LIMIT CURRENT	: 4000A
BURDEN	: 0.6Ω	SHORT TIME CURRENT	: 63kA/1SEC
FREQUENCY	: 50HZ	RANGE OF LOADING	: 20A to 4000A

DRAWING

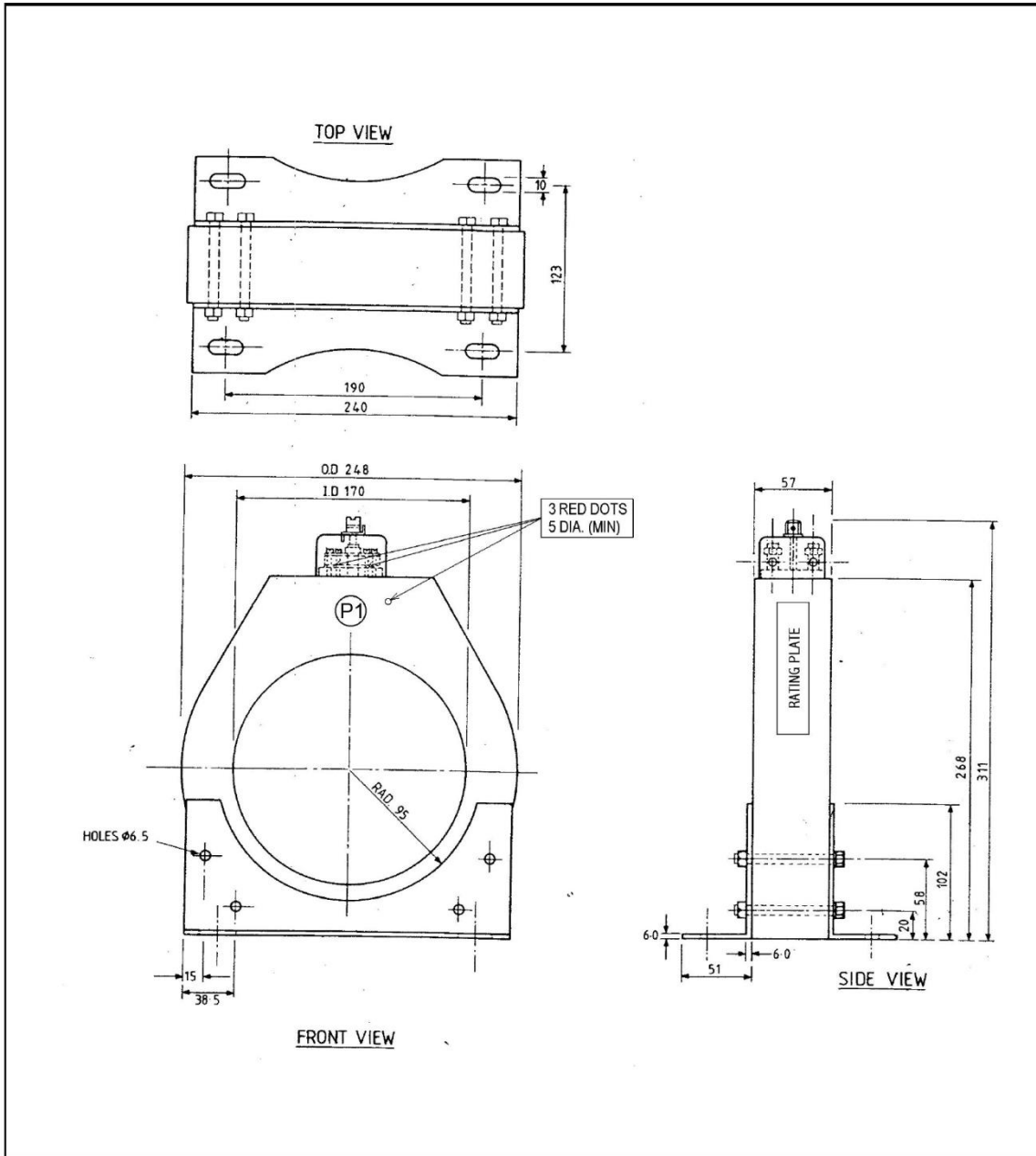

			DESCRIPTION			
			FORM U170 RATIO 2000 / 5 CLASS 0.5S 15VA			
			MATERIAL: ABS INJECTION MOULDED PLASTIC CASE			
			FINISH: CLEAR TERMINAL COVER/ MOUNTING BRACKET			
DATE	ALTERATIONS	CHK	ALL DIMENSIONS IN MILLIMETERS			SCALE: NTS
ISS No.	APPROVED BY	DATE	DRAWN	JAMES.M.JEFFREY	21-04-15	TOLERANCE (UNLESS SPECIFIED)
			CHECKED	S.COSTER	21-04-15	+/- 0.5
			APPROVED	S.COSTER	21-04-15	SHEET 1 OF 1
						PART NUMBER 24U170CL05S/5