



LED-W4000

User manual V2.0

 Before using this video processor, please read this manual carefully and keep it for reference in the future.

MAGNIMAGE

8k×2K Video Processor

Statements

Without the written permission, any unit or individual could not copy, reproduction or translate the book or part of it. Also could not transmit it in any form or any way (electronic, mechanical, photocopying, record or other way) for any business and profitable purpose.

The product specifications and information mentioned in this manual is just for reference, will not give prior notice if there is any update. Unless there is a special agreement, it is just used as guidelines. All the statements or information in this manual shall not constitute any form of guarantee.

Directory

Briefs	1
Trademark credit.....	1
About the software.....	1
Features.....	2
Expanded ports	3
Safety instructions	4
Function Introduction.....	5
Brief.....	5
The front panel.....	6
The front panel.....	7
The rear panel	8
Technical specifications.....	11
User Menu.....	14
How to use the buttons.....	15
MENU area:.....	15
LAYER area:	16
INPUT area:	16
FUNCTION area:	17
Default status introduction.....	18
Main menu introduction.....	20
Main menu	22
Picture setting menu.....	23
Output setting menu.....	26
Input setting menu	33
Layers setting menu	39
Save & Load	47
EDID setting	49
COMM. setting menu	51
MISC. menu.....	52
TEST PATTERN.....	61
Language submenu	64
Quick Use Instructions	65
The rear panel introduction.....	65
The front panel introduction	67
Input signal information, TILE function introduction.....	69
Working mode introduction	71
Mosaic mode function.....	71
Switcher function.....	74
Backup mode function introduction.....	77

Warranty Description	79
Machine warranty	79
Non-warranty.....	79

Briefs

Thanks for your purchasing our LED video processor. Do hope you can enjoy the experience of the product performance. The design of the LED video processor conforms to international and industry standards. But if with improper operation, there will be a personal injury and property damage. In order to avoid the danger, please obey the relevant instructions when you install and operate the product.

Trademark credit

- VGA and XGA is a registered trademark of IBM.
- VESA is a Video Electronics Standards Association's trademark.
- HDMI, HDMI mark and High-Definition Multimedia Interface are all from HDMI.
- Even if not specified company or product trademarks, trademark has been fully recognized VESA is a Video Electronics Standards Association's trademark.

About the software

Do not change, decompile, disassemble, decrypt or reverse engineer the software installed in the product, these acts are illegal.

Features

- 8K x 2K mosaic outputs: W4000 has two output modes: DVI output and HDMI output. The outputs are divided into two groups, each group including 4 DVI and 2 HDMI 2.0
- Multiple input ports: DVI-D (4K×1K/60Hz), DP1.1, HDMI1.4, SDI (3G-SDI)
- Two expanded input ports: DP1.2 (4K×2K/60Hz or 8K×1K/60Hz) and HDMI 2.0
- Different working modes are available: Mosaic mode, HDMI Switcher mode, Backup mode
- Mosaic mode: 8K×2K/60Hz input and output pixel-to-pixel display
- HDMI Switcher mode: 4K preview/switch, seamless switching between 3 layers and 3 layers
- Backup mode: input signal hot backup or manual backup and seamless switching between input signal or tile input
- Multi-machine cascading mosaic synchronously, and Take seamless switching
- HDR 10
- 10 BIT processing
- HDCP1.4 & 2.2 compliant
- Touched screen operation
- Supports saving & loading of maximum 20 presets, and time tasks
- Supports setting of brightness, Gamma, contrast, saturation, color temperature etc., low light level and high gray level
- Built-in test pattern
- Supports pixel point acquisition, real-time display of RGB values of pixels at any position in the output window
- Supports PC software control, network port and RS232 connection
- Supports LOGO, chroma key function
- Supports USB upgrade

Expanded ports

The LED-W4000 is the basic model. Based on this model, it can be expanded with two 4K/60Hz inputs (DP1.2+HDMI2.0).

The expanded models are shown in the following table:

Available expanded module		Corresponding model	Description
Input module	Expand one 4K/60Hz input modules	LED-W4000-DH	The 4K/60Hz input module includes one DP1.2 input and one HDMI 2.0 input+one HDMI loop out. Either DP or HDMI port is used at one time.
	Expand two 4K/60Hz input modules	LED-W4000-2DH	The 4K/60Hz input module includes one DP1.2 input+one HDMI 2.0 input+one HDMI loop out. Either DP or HDMI port is used at one time.

Safety instructions

- Please use the correct power supply according that the power input voltage for this product range is 100 ~ 240V AC, 50/60Hz.
- When you need connect or pull out any signal or bound guideline. Please confirm that all the power supply cords have been pulled out ahead.
- When you need to add hardware device for the LED video processor, make sure all of the signals and power cables have been pulled out ahead.
- Before you operate any hardware, please turn off the LED video processor's power, and to set you on the electrostatic by touching the ground surfaces.
- Please use the processor in clean, dry and ventilated environment, not use it in the high temperature, humidity environment.
- The product is the electronic product; please stay away from the fire, water and of which is inflammable and blast, dangerous.
- This product is with high pressure components, please don't open the case or maintain it by your own.
- As there is exceptional condition with smoke, ill-smelling, please turn off the switch at once and contact with the dealers.

Function Introduction

Brief

LED-W4000 series is an 8K x 2K video processor which integrates multiple functions such as mosaic, switcher and multi-window display. This processor integrates various professional input ports, single input support maximum 4Kx2K/60Hz or 8Kx1K/60Hz. Because of the high-quality images, pixel display of giant resolution and flexible operation ways, it's widely used in exhibitions, business conferences, stage performances, theaters and TV stations etc.

The load capacity of LED-W4000 series is several times of normal video processor, support EDID management and customized output resolution, single processor output can be maximum 8192 pixel width, refresh rate up to 120Hz, greatly improved the utilization of load capability. It also provides various regular output resolution options for scaling according to real size of LED screen.

Perfect video inputs ports, including SDIx1, DVIx4, HDMIx3, DPx4, and it also allows you to expand 2 more DP1.2/HDMI2.0 inputs. It supports internet and RS232 control to link with various video equipment.

The front panel

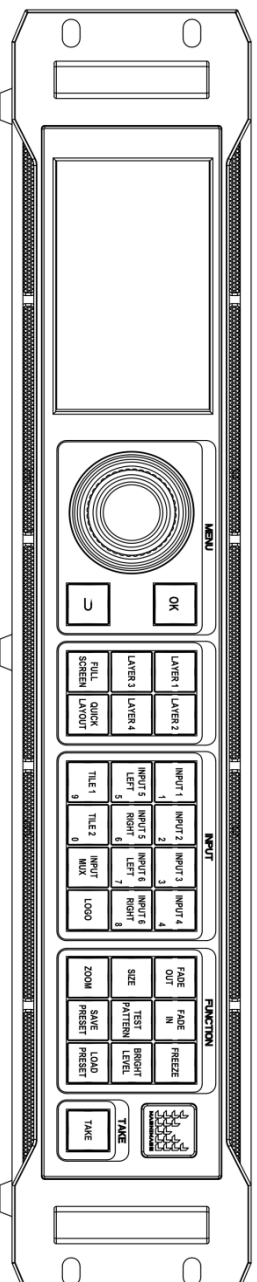

Button			
Knob	Select the menu and adjust	INPUT 2	Input 2/Number button 2
OK	Enter the menu or confirm the current setting	INPUT 3	Input 3/Number button 3
↶	Return to the previous menu	INPUT 4	Input 4/Number button 4
LAYER 1	Layer 1	INPUT 5 LEFT	Left part of Input 5/Number button 5
LAYER 2	Layer 2	INPUT 5 RIGHT	Right part of Input 5/Number button 6
LAYER 3	Layer 3	INPUT 6 LEFT	Left part of Input 6/Number button 7
LAYER 4	Layer 4	INPUT 6 RIGHT	Right part of Input 6/Number button 8
FULL SCREEN	Make the current layer full screen to the output port	TILE 1	Combined Input 1/Number button 9
QUICK LAYOUT	Quick layout button	TILE 2	Combined Input 2/Number button 0
INPUT 1	Input 1/Number button 1	INPUT MUX	Shortcut button of input configuration

The front panel

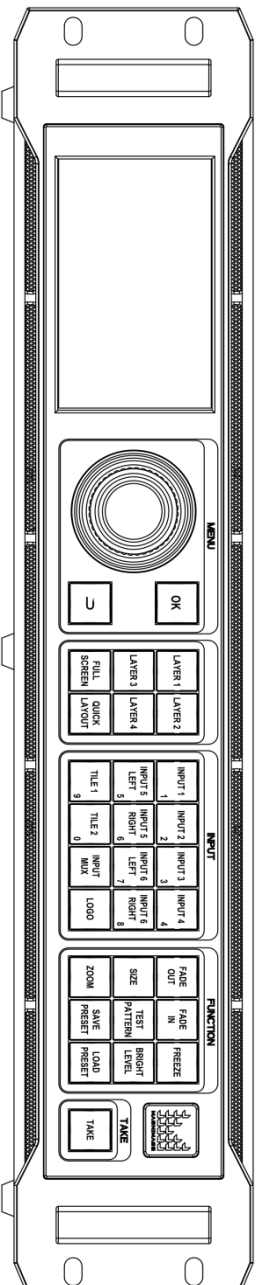

Button instruction		
LOGO	LOGO On/Off	BRIGHT LEVEL
FADE OUT	The selected layer fades out	ZOOM
FADE IN	The selected layer fades in	SAVE PRESET
FREEZE	Freeze the output image	LOAD PRESET
SIZE	Shortcut button of layer size	TAKE
TEST PATTERN	Shortcut button of test pattern	

Input ports	
INPUT 1	DVI×1, DP×1, SDI IN×1, SDI LOOP×1, choose one of the three to use at one time
INPUT 2	DVI×1, DP×1, HDMI×1, choose one of the three to use at one time
INPUT 3	DVI×1, DP×1, HDMI×1, choose one of the three to use at one time
INPUT 4	DVI×1, DP×1, HDMI×1, choose one of the three to use at one time
INPUT 5 (expanded)	DP×1, HDMI×1, HDMI LOOP×1, choose one of the two to use at one time
INPUT 6 (expanded)	DP×1, HDMI×1, HDMI LOOP×1, choose one of the two to use at one time
Output ports	
DVI 1A-DVI 1B	DVI 1 output, DVI 1A= DVI 1B
DVI 2A-DVI 2B	DVI 2 output, DVI 2A= DVI 2B
DVI 3A-DVI 3B	DVI 3 output, DVI 3A= DVI 3B
DVI 4A-DVI 4B	DVI 4 output, DVI 4A= DVI 4B
HDMI 1A-HDMI 1B	HDMI 1 output, HDMI 1A= HDMI 1B
HDMI 2A-HDMI 2B	HDMI 2 output, HDMI 2A= HDMI 2B

12 output ports are divided into 2 groups.

First group includes HDMI 1A/1B, DVI 1A/1B and DVI 2A/2B.

Second group includes HDMI 2A/2B, DVI 3A/3B and DVI 4A/4B.

DVI and HDMI are mutual exclusive, so please use either all DVI outputs or HDMI outputs.

Control interface	
RJ45×1	Network cable port, control the machine by LAN
USB×1	USB upgrade port, upgrade the machine by a USB flash drive
RS232×1	RS232 port
GENLOCK IN×1 OUT×1	Genlock port

Technical specifications

Standard input indication		
Ports	Qty	Resolution specification
DVI	4	3840×1080/60Hz and other VESA compliant resolutions, supports EDID management
DP1.1	4	Supports 3840×1080/60Hz, 3840×2160/30Hz and EDID management
HDMI1.4	3	Supports 3840×1080/60Hz and EDID management
SDI	SDI IN×1 SDI LOOP ×1	480i/60Hz, 576i/50Hz, 720p/60HZ, 1080i/50Hz, 1080i/60Hz, 1080P/60Hz (3G SDI)

Expanded input indication		
Ports	Qty	Resolution specification
DP1.2	DP×1	Supports 3840×2160/60Hz, 7680×1080/60Hz and customized resolution
HDMI 2.0	HDMI×1,HDMI LOOP×1	Supports 3840×2160/60Hz and customized resolution

One single 4K expanded module includes DP×1, HDMI×1 and HDMI LOOP×1. DP and HDMI ports are either-or used.

Output indication

Ports	Qty	Resolution specification (single output port).
DVI	4×2	1024×768/60Hz 1600×1200/60Hz 1920×1200/60Hz 1280×1024/60Hz 1600×1200/60Hz Rdc 1936×1280/60Hz 1024×768/120Hz 1680×1050/60Hz 2048×1152/60Hz 1280×720/59.94Hz 1920×1080/59.94Hz 1024×1280/60Hz 1280×720/60Hz 1920×1080/60Hz 1536×1536/60Hz 2048×1920/60Hz 1920×1080/50Hz Customized output resolution (bandwidth optimization). Horizontal resolution up to 2048 pixels. Vertical resolution up to 3840 pixels.
HDMI	2×2	1920×1080/60Hz 1920×1080/120Hz 3840×1080/60Hz 3840×2160/30Hz 3840×2160/60Hz 4096×1280/60Hz 4096×2160/30Hz 4096×2160/60Hz 2560×1080/120Hz 2560×1440/90Hz Customized output resolution (bandwidth optimization). Horizontal resolution up to 4096 pixels. Vertical resolution up to 3840 pixels.

Machine specification	
Input power	100-240V AC~50/60Hz 0.6A
Operating temperature	0-45°C
Dimensions	482.6×446.3×92.5mm (L × W × H)
Net weight	6.7KG
Power	90w

User Menu

With the user manual, the machine can be easily set to meet the user's requirements.

The LED-W4000 series processor has a full-color single-touch LCD display to show the entire user menu. The default status will be displayed on the LCD screen when the user has no operation or the operation has timed out. If operating with the buttons on the front panel, the corresponding menu will be displayed on the LCD screen according to feedback to the user for operation better, faster and more intuitively.

In the following we will introduce the menu system of the LED-W4000 series processor with its buttons, function and the LCD display.

How to use the buttons

The front panel buttons are divided into 5 areas: MENU, LAYER, INPUT, FUNCTION and TAKE.

MENU area:

This area includes 2 buttons and 1 knob that can be pressed: OK, \Rightarrow and knob. Short press “**knob**”, its function is the same as the confirmation button (**OK**); Press the return button (\Rightarrow), the system will return to the previous menu until it returns to the default state, or long press to return to the main menu.

In the main menu, the confirmation button is also used to switch between the browsing mode and the setting mode, for example:

Browsing mode	Setting mode																
<table border="1"><tr><td>Layer 1 image</td><td></td></tr><tr><td>Brightness</td><td>50</td></tr><tr><td>Contrast</td><td>50</td></tr><tr><td>Saturation</td><td>50</td></tr></table>	Layer 1 image		Brightness	50	Contrast	50	Saturation	50	<table border="1"><tr><td>Layer 1 image</td><td></td></tr><tr><td>Brightness</td><td>50</td></tr><tr><td>Contrast</td><td>50</td></tr><tr><td>Saturation</td><td>50</td></tr></table>	Layer 1 image		Brightness	50	Contrast	50	Saturation	50
Layer 1 image																	
Brightness	50																
Contrast	50																
Saturation	50																
Layer 1 image																	
Brightness	50																
Contrast	50																
Saturation	50																
Press OK button or tape the knob to switch these two modes																	

In the browse mode, turn the knob counterclockwise to move the cursor to the top or left; turn the knob clockwise to move the cursor down or to the right.

Move the cursor to the item to be adjusted, press the knob or confirm button to enter the setting mode. At this time, turn the knob counterclockwise to decrease the current parameters value; turn the knob clockwise to increase the current parameters value. To continue setting up other items on this page, please switch back to browsing mode. To return to the previous menu, use the back button; If the adjustment is complete, press the return button to return to the previous menu until the default state, or wait for the system to time out, automatically return to the default state. In some special interface,

the system will not automatically return to the default state, such as user mode shortcut interface, test pattern interface, etc.

LAYER area:

This area includes 6 buttons, LAYER 1, LAYER 2, LAYER 3, LAYER 4, FULL SCREEN and QUICK LAYOUT.

LAYER 1-4 corresponds to the 4 layers of the machine. Short press the button to select the screen. Press and hold the button to open or close the corresponding layer. The used one is on white, and the current selection is on red.

FULL SCREEN: Allows the currently selected layer to be full-screen with one button in the corresponding output port;

QUICK LAYOUT: Long press for 3 seconds to directly change to matrix output mode.

INPUT area:

This area includes 11 buttons: INPUT 1, INPUT 2, INPUT 3, INPUT 4, INPUT 5 LEFT, INPUT 5 RIGHT, INPUT 6 LEFT, INPUT 6 RIGHT, TILE 1, TILE 2, LOGO. Among them, INPUT 5 LEFT, INPUT 5 RIGHT, INPUT 6 LEFT, INPUT 6 RIGHT correspond to the processor's two expanded inputs. DP1.2 and HDMI2.0 will be divided into left and right parts when using inputting 4K×2K/60Hz input, which corresponding to the LEFT and RIGHT of the button.

TILE 1 and TILE 2: Quick use Tile signal, specific operating please see Tile Key configuration menu.

INPUT MUX: Shortcut button to INPUT MUX menu, configure input 1-6 separately (each group use which input port).

LOGO button: Open and close logo function.

When there is a input signal, the corresponding input key turn white. The currently selected input signal is red.

Select layer first, and then select the input signal.

FUNCTION area:

FUNCTION area includes 9 buttons: FADE OUT, FADE IN, FREEZE, SIZE, TEST PATTERN, BRIGHT LEVEL, ZOOM, SAVE PRESET and LOAD PRESET.

Buttons	Default operation
FADE OUT	Fade out the selected layer
FADE IN	Fade in the selected layer
FREEZE	Freeze current image
SIZE	Enter resize menu interface
TEST PATTERN	Open the test pattern interface
BRIGHT LEVEL	Open the brightness level adjustment interface
ZOOM	Open the layer zoom interface
SAVE PRESET	Enter the preset interface to save presets
LOAD PRESET	Enter the preset interface to load presets

Default status introduction

After power on the LED-W4000 series processor, the boot interface will be displayed on the LCD screen of the front panel during system start up. After the start-up is completed, the main interface of the current machine will be displayed as the default state, as shown below.

Figure 1 default status interface after power on.

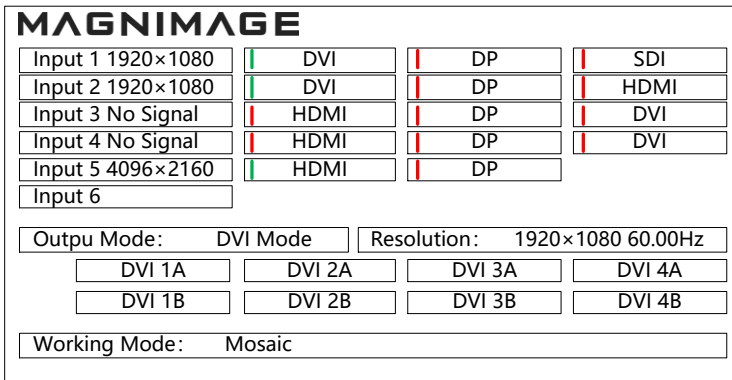

Here is the instruction of the above:

	Instruction
Input 1 1920x1080	Input 1 and current input signal resolution, the right side is the 3 input sources corresponding to input 1. For the vertical bar on the left side of each signal source, green indicates have signal, red indicates no signal. The font color of each source is divided into yellow and white: yellow means that the signal is set as the input, and white means that this signal is not set as the input (this also applies to Input 2, Input 3, Input 4, Input 5, Input 6 right side display content).
Input 2 1920x1080	Input 2 and current input signal resolution, and the right side is the 3 input sources of Input 2.
Input 3 No Signal	Input 3 and current input signal resolution, and the right side is the 3 input sources of Input 3.



Input 4 No Signal	Input 4 and current input signal resolution, and the right side is the 3 input sources of Input 4.
Input 5 4096×2160	Input 5 and current input signal resolution, the right side is the 2 input sources of Input 5. If this expansion board is not added, it will not be displayed here.
Input 6 No Signal	Input 6 and current input signal resolution, the right side is the 2 input sources of Input 6. If this expansion board is not added, it will not be displayed here.
Output mode	Display the current output mode of the processor: DVI mode or HDMI mode.
Output resolution	Display the output resolution of a single DVI or HDMI output.
Layer 1-4	Display the input signal of current layer Turns green: layer is open and used. Turns red: layer is closed or unused.
Working mode	Display the work mode of the processor, including mosaic mode, switcher mode (HDMI) and backup mode.
— —	Synchronization label: W4000's inputs & outputs are synchronized

Main menu introduction





The sub-symbols listed in the table below will appear in the main menu. For the specific meanings, please see the following table:

Symbol	Introduction
	Press the back button or touch this symbol to return to the main interface or return to the previous menu

In the main menu, you can use "OK", "↩" and the knob or touch the corresponding menu to make adjustment setting. The operation mode is as follows:

Operation	Buttons
Open the main menu	Press the "OK" button or press the knob in default status.
Select each menu	Rotate the knob to select each menu or touch on the corresponding menu.
Adjust parameters	When the right end of the item is a number or option parameters, press the knob to select the parameters whirling knob, or touch the "  "" "  " to adjust the parameters to be smaller or bigger, or touch the parameters in the pop-up numeric buttons input area for parameters adjustment.
Go to the next menu	When the right end of the item is the "  " symbol, press the "OK" button or press the knob or touch the menu.
Execute a function	Use the knob to select the item to be executed, press the "OK" button or touch the function.
Return to the previous menu	Press the "↩" button or touch the button to return.
Confirmation	In order to avoid misuse during resetting, you need to

	confirm the operation or touch click with the "OK" button.
Menu button appears white frame	Indicates that the menu has been selected by the knob to proceed to the next step.
Function menu font yellow	Indicates that the function menu is being used.
Function menu font white	Indicates that the function menu is not in used.

Description of the numeric keypad: for any parameters that need to be modified, in addition to pressing the knob, rotating and touching the left and right direction keys, you can also click the corresponding parameters to pop up the numeric keypad on the screen to setup. 0 to 9 indicate a number,  indicates a decimal point,  indicates that exiting the numeric keypad mode,  indicates that the modified parameters is confirmed,  indicates that backspace to delete the entered number. The numeric keypad is shown below.

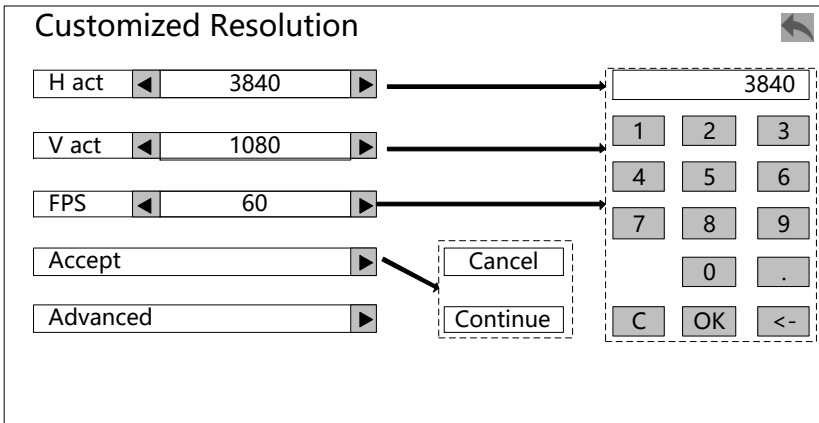

Main menu

Press “OK” or rotary the knob, you will enter the main menu, and the LCD screen will show as below:

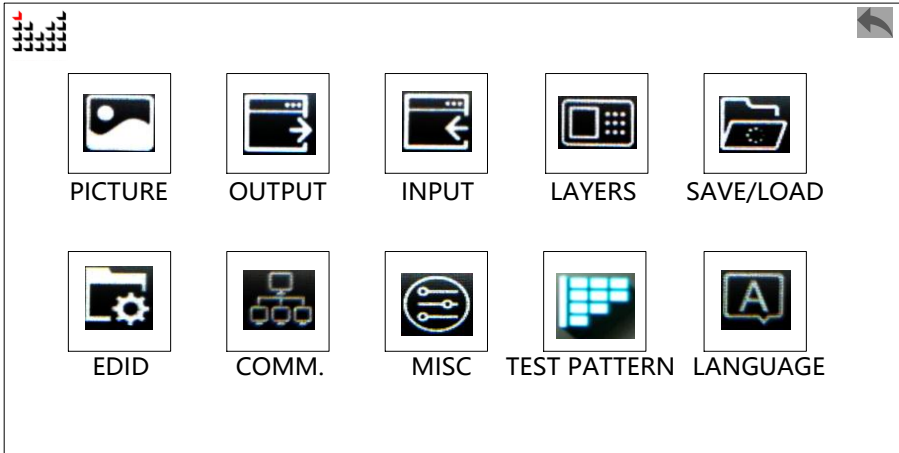

Totally 10 items, selected by rotate the knob; The color of selected item is yellow, otherwise is white; Then press “OK” enter the item, press “↩” to return. We can also touch the LCD screen to select the item.

Picture setting menu

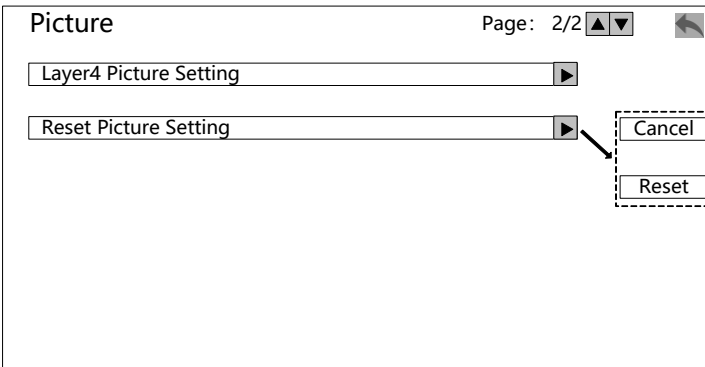
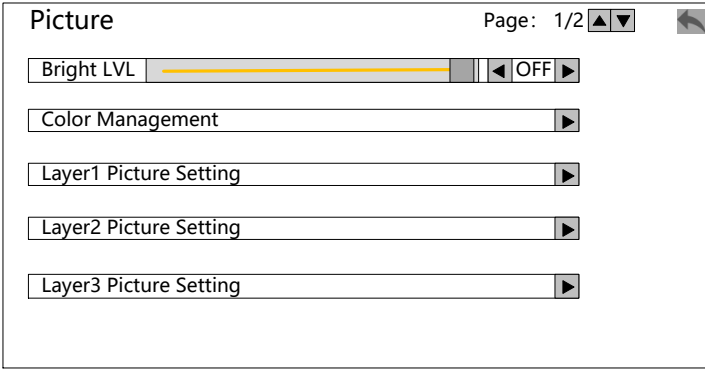

Color management:

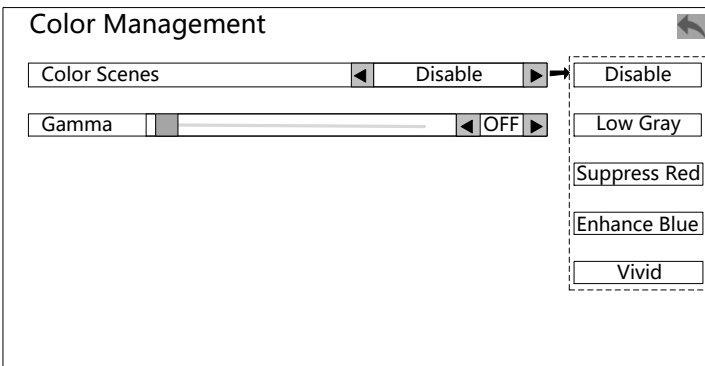

Layer 1~4 picture setting:

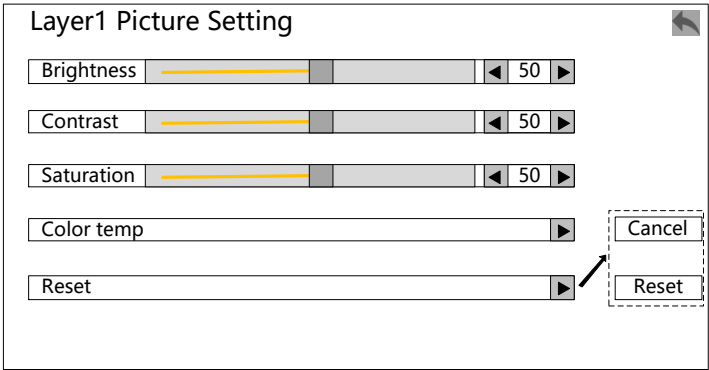

Layer 1~4 color temperature setting:

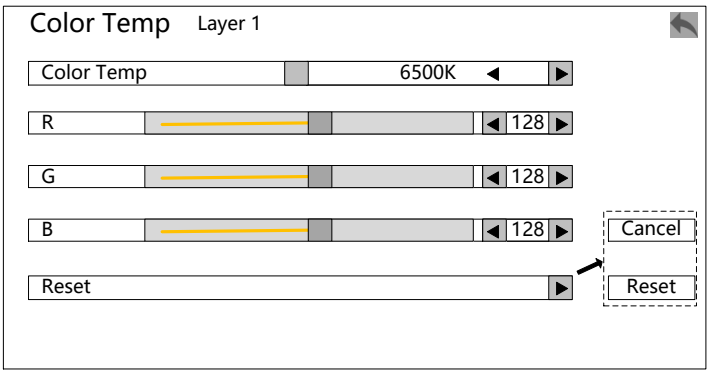







Bright LVL	Turn on/off the function, level 0~16.
Color Management	Color Scenes Low gray, red attenuation, blue enhancement and bright, disabled by default.
	Gamma Turn on/off, Gamma range 0.0~5.0.
Layer 1~4 Picture Setting	Brightness: range 0~100, 50 by default.
	Contrast: range 0~100, 50 by default.
	Saturation: range 0~100, 50 by default. "4000K", "5000K", "6500K", "7500K", "8200K", "9300K", "1000K", "11500K", "user"9 options.
	Layer 1~4 Color Temp Red range 0~255, 128 by default. Green range 0~255, 128 by default. Blue range 0~255, 128 by default
	Reset the picture parameters to the default setting.

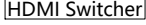

Note: The arrow point to the submenu that pops up for this option.

Output setting menu

Output 

Working Mode   

Output Mode   

Resolution  

Window 

HDMI Setting 

DVI mode resolution :

Resolution Page: 1/1 

1024×768 60Hz	1600×1200 60Hz	1920×1200 60Hz
1280×1024 60Hz	1600×1200 60Hz Rdc	1936×1280 60Hz
1024×768 120Hz	1680×1050 60Hz	2048×1152 60Hz
1280×720 59.94Hz	1920×1080 59.94Hz	1024×1280 60Hz
1280×720 60Hz	1920×1080 60Hz	1536×1536 60Hz
2048×1920 60Hz	1920×1080 50Hz	Customized

Resolution 

Set Output Resolution To 1920×1080 60Hz

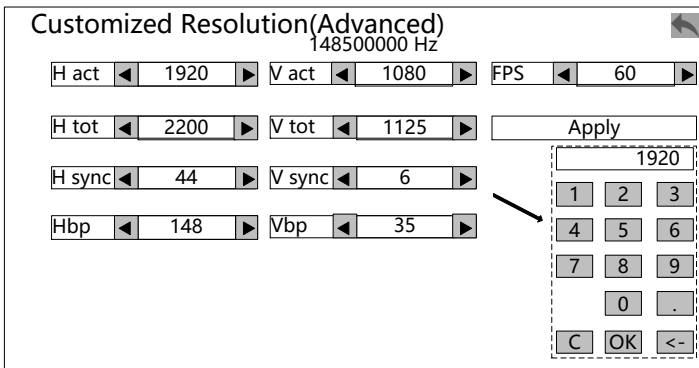
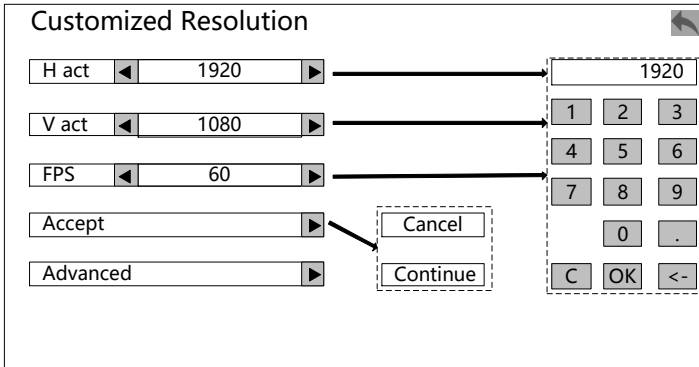

HDMI mode resolution :

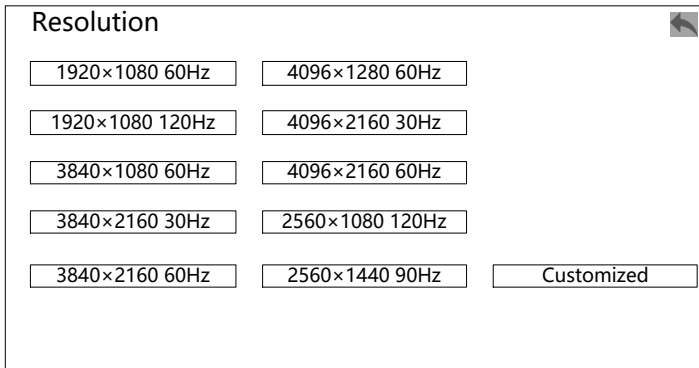

Resolution

Set Output Resolution To 1920×1080 60Hz

Cancel Accept

Customized Resolution

H act ◀ 3840 ▶

V act ◀ 1080 ▶

FPS ◀ 60 ▶

Accept ▶

Advanced ▶

Cancel

Continue

3840

1	2	3
4	5	6
7	8	9
	0	.
C	OK	<-

Customized Resolution(Advanced)

294000000 Hz

H act ◀ 3840 ▶ V act ◀ 1080 ▶ FPS ◀ 60 ▶

H tot ◀ 4400 ▶ V tot ◀ 1125 ▶ Apply

H sync ◀ 32 ▶ V sync ◀ 5 ▶

Hbp ◀ 80 ▶ Vbp ◀ 36 ▶

3840

1	2	3
4	5	6
7	8	9
	0	.
C	OK	<-

Window (take HDMI output as an example) :

Output Panel Config

Window

Panel Layout

Window

HDMI1 HDMI2 OFF ON

Reset

H Pos 0 Width 3840

V Pos 0 Height 1080

Panel Layout

HDMI1 HDMI2 Window

H Pos 0 V Pos 0

Horizontal Vertical Windows

H Pos	0
V Pos	0
Width	3840
Height	1080

HDMI setting:

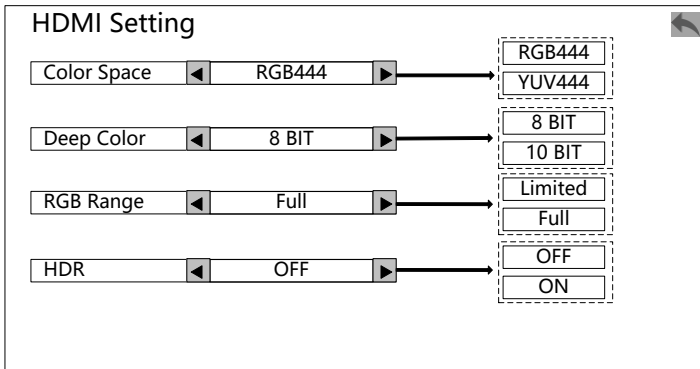

Mosaic mode, HDMI Switcher mode and Backup mode.

Mosaic mode: Support maximum 4 layers mosaic output.

Take DVI for example, it supports 2 inputs mosaic to 3 outputs, 3 inputs mosaic to 4 outputs, 4 inputs mosaic to 4 outputs.

Switcher mode: Only support HDMI output on switcher

mode, HDMI 2 output as preview (Output monitor will have "preview" in red), HDMI1 as program output, when output resolution under 4K×1K, it support 3 layers preview switching to 3 layers, while on 4K×2K, only support 1 layer to 1 layer preview switching.

Backup mode: Support automatic hot backup and manually backup, and multi-machine backup synchronously. Support main and aux output switching fade in/out.

Working Mode

Output Mode	DVI and HDMI two output modes, that is, DVI output or HDMI output.
Resolution	DVI mode: 17 fixed resolution and 1 customize resolution (the 18 th item). When user-customize, the widest resolution is 2048, the highest is 1536, maximum

	frequency is 120 Hz, see " output indicators " for details. 2 group of outputs's resolution is the same.
Window	<ol style="list-style-type: none"> 1. Including output window and output layout two parts. 2. Output layout support automatic layout. 3. On switcher working mode, output window's size is fixed, could not adjust.
HDMI Setting	Only workable on HDMI output mode. Adjust HDMI output format, which have: color space(RGB444 and YUV444), color depth(8 BIT AND 10BIT),RGB tone range (limited and full). HDR function open and close.

Please set the right output resolution, width and height according to the LED screen. If no proper output resolution, please select a bigger resolution option than the real LED screen resolution. Or we can use customize resolution, pixel to pixel with the LED screen.

For example, a LED screen resolution is 1152*960, then we can choose the option "1280×1024/60Hz". Then set the width to "1152", height is "960". If use customize resolution, just set the width and height to 1152 and 960, then the machine will offer"1152×960"output resolution.

Notice 1: Arrow points to the submenu of the selected item.

Notice 2: The resolution of LED-4000's 4 groups of DVI outputs are always the same, so does 2 groups of HDMI outputs, but the size of output window can be different.

Notice 3: Please use with caution of the resolution with over 60 Hz, or super wide/high pixels, the backend device may not support this resolution.

Notice 4: User-customize output resolution is not standard signal, some of the monitors may not recognize, but this does no influence to LED big screen display.

About HDR:

1. Adopt HDR 10 format, input/output 10 BIT.
2. Single HDMI output on 4K×2K/60Hz, 8BIT bandwidth range, under 10BIT mode, the load is reduced by about a third, recommend use on 4K×1K/60Hz 10BIT range.
3. Signal only input from input 5 or 6 input port.
4. HDR function on this machine work as “Bridge”,and the input signal, and the device which connect with output both support HDR function.

Input setting menu

Input 

Input Signal Information 

Input MUX Config 







Tile Keys Config 

Image Crop 



Digital Input Color Range 

Input Information For Layers 

Input Signal Information:

Input Signal Information Page: 1/2   

01: Input1-DVI	1920×1080	Total: 2200×1125
02: Input1-DP	No Signal	
03: Input1-SDI	No Signal	
04: Input2-DVI	1920×1080	Total: 2200×1125
05: Input2-DP	No Signal	
06: Input2-HDMI	No Signal	
07: Input3-HDMI	No Signal	
08: Input3-DP	No Signal	

Input Signal Information Page: 2/2   

09: Input3-DVI	No Signal	
10: Input4-HDMI	No Signal	
11: Input4-DP	No Signal	
12: Input4-DVI	No Signal	
13: Input5-HDMI	4096×2160	Total: 4096×2160
14: Input5-DP	No Signal	
15: Input6-HDMI	No Signal	
16: Input6-DP	No Signal	

Input MUX Config: Configure each group input from which input port.

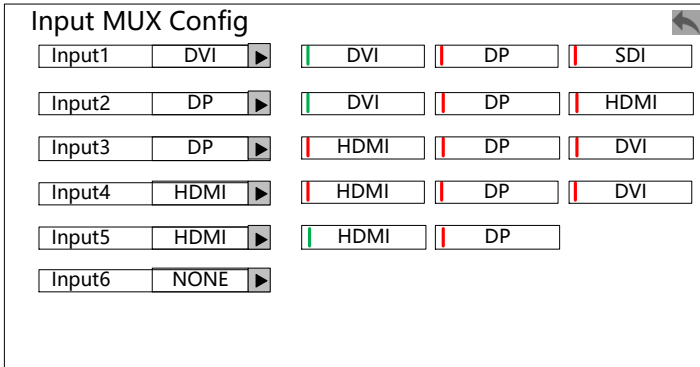

The 'Input MUX Config' dialog box contains six rows, each representing an input group. Each row has a dropdown menu for the group name and a set of three buttons for selecting the source input port. The buttons are color-coded: green for the selected port, red for other available ports, and grey for unavailable ports.

Group	Selected	Available	Unavailable
Input1	DVI	DVI	DP, SDI
Input2	DP	DVI	DP, HDMI
Input3	DP	HDMI	DP, DVI
Input4	HDMI	HDMI	DP, DVI
Input5	HDMI	HDMI	DP
Input6	NONE		

TILE Keys Config: Combine multiple input signals to a Tile.

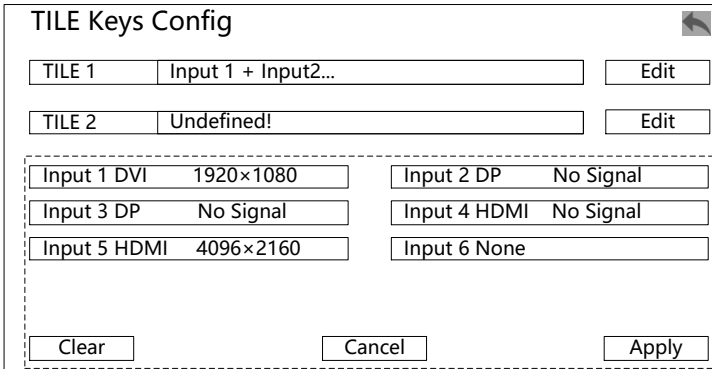

The 'TILE Keys Config' dialog box shows two tiles. 'TILE 1' is configured with 'Input 1 + Input2...' and has an 'Edit' button. 'TILE 2' is 'Undefined!' and also has an 'Edit' button. Below these is a dashed box containing a table of input signals and their resolutions. At the bottom are 'Clear', 'Cancel', and 'Apply' buttons.

Tile	Configuration	Action
TILE 1	Input 1 + Input2...	Edit
TILE 2	Undefined!	Edit

Input	Signal	Resolution
Input 1	DVI	1920×1080
Input 2	DP	No Signal
Input 3	DP	No Signal
Input 4	HDMI	No Signal
Input 5	HDMI	4096×2160
Input 6	None	

Buttons: Clear, Cancel, Apply

Image crop:

Image Crop 

Input 1 Input 2 Input 3 Input 4 Input 5 Input 6

DVI Input 1 1920×1080 

DP Input 1 No Signal 



SDI Input 1 No Signal 







Image Crop DVI Input 1 

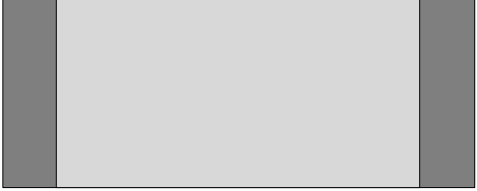





 Function OFF

Function ON

Reset







Match To Input

H Pos  0  Width  1920  H Range  1920 

V Pos  0  Height  1080  V Range  1080 

Digital Input Color Range:

Digital Input Color Range When RGB Info Available 

Input 1	Auto 	Auto	Limited	Full
Input 2	Auto 	Auto	Limited	Full
Input 3	Auto 	Auto	Limited	Full
Input 4	Auto 	Auto	Limited	Full
Input 5	Auto 	Auto	Limited	Full
Input 6	Auto 	Auto	Limited	Full

Input Information For Layers:

Input Information For Layers			
Layer 1	Input1-DVI	1920×1080	60.00Hz
Layer 2	Input2-DP	No Signal	
Layer 3	Input3-SDI	No Signal	
Layer 4	Input4-DVI	1920×1080	60.00Hz

Input Signal Information	Display all the input signals' information of each input port, the content sequence — signal type — input resolution or no signal — the bandwidth of current input port.
Input MUX Config	By rotating knob or touching the screen to choose the main signal of each input MUX. Select main input signals of input 1 to input 6, corresponding to 3 or 2 input sources on the right side. The left side of each input source, green strip means valid signal, red strip means no signal. White and yellow text: yellow means this source is the input MUX of corresponding input, white means not yet used.
TILE Keys Configuration	Through Tile,multiple signal combine to one signal, support 2 groups tile,Tile 1 and Tile 2. By press "EDIT" key,there shows a choice box, we can add several input signals into combination. The signal not in Tile will be showed as " Undefined ",click " EDIT " to change if needed.
Image crop	All sources of input 1-6 can be cropped freely. By knob or screen touching, select the input 1-6, then select the source, then enter the menu of image crop to crop the image.
	DVI Input 1 It means the sequence and input signal

	under cropping.	
Function off	Turn off the image crop function.	
Function on	Turn on the image crop function	
reset	Reset the parameters of image crop.	
Match input signal	Match the image parameters between input signal and below image crop.	
Image crop parameter setting	H position	Alter the horizontal position of image crop.
	H width	Alter the horizontal width of image crop.
	H datum	Alter the horizontal datum of image crop.
	V position	Alter the vertical position of image crop.
	V height	Alter the vertical height of image crop.
	V datum	Alter the vertical datum of image crop.
Digital Input Color Range	Default to automatic, limited and full is alternative.	
Input Information For Layers	See all layers input information, including: current layer's port number, resolution, refresh information (accurately to 0.01).	

Note 1: In the “Input Signal Information”, after expanded the module then there shows 13-16 item; If not, no 13-16 item.

Note 2: When using Tile, all the selected input sources should have the same resolution. Tile support up to 4 sources to combine.

Note 3: When using image crop, please select input 1 to 6, then select the signal need to be cropped, in the below area.

Note 4: Image crop function is selected a part of input signal, then according to the layer size output to the LED screen. So the image crop window size and position are always limited in the input signal resolution. All the setting in the table above are mutually restrictive.

About Tile key configuration:

1. On mosaic mode and backup mode, support 4*2K×1K, 2*2K×1K or 2*2K×2K range input signal combine to a Tile.
2. On switcher mode, support 2*2K×1K range input signal combine to a Tile.
3. Only same resolution signals could be combined to a Tile.
4. Tile function only support right and left horizontal tile.

Layers setting menu

Layers Setting menu: It has a slightly differences on mosaic mode, switcher mode, and backup mode, specific introduce as below,

On mosaic mode: support layer quick setting.

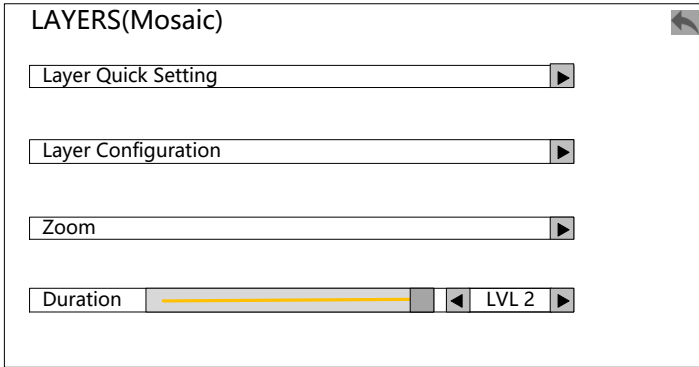

Layer Quick Setting (Auto layout):

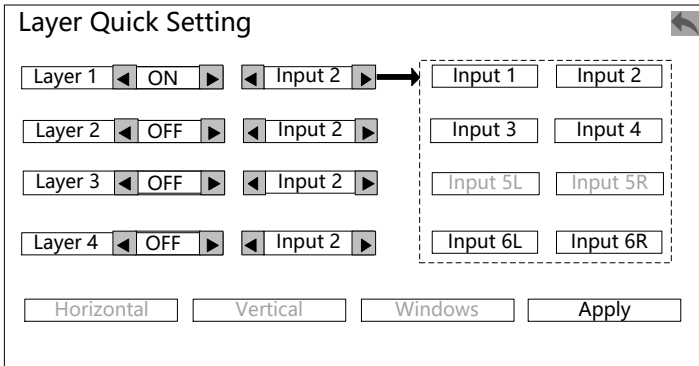

Layer configuration: manually open/close layer, modify layer's size, position, rotation.

The image displays three stacked control panels for video layer configuration:

- Layer Configuration:** Features buttons for Layer 1, Layer 2, Layer 3, Layer 4, OFF, and ON. A central area shows a grid of four colored rectangles (white, light gray, medium gray, dark gray) with a yellow border. Below this are sliders for H Pos (0) and V Pos (0), and numeric input fields for Width (3840) and Height (1080). A 'Layer Property' button is on the right.
- Layer Property:** Shows 'Layer 1' selected. It includes a 'Chroma Keyer' dropdown menu and an 'Alpha' slider set to 64.
- Chroma Keyer:** Titled 'Layer 1 Only Show Colors Defined Below'. It contains six sliders for R Low, G Low, B Low, R High, G High, and B High, all set to 0. A 'Function OFF' button is next to R Low, 'Function ON' next to G Low, and a 'Quickset' button next to R High.

Chroma Keyer Layer 1 Quickset 

Pure Red	Pure Green	Pure Blue
Red Screen Matting	Green Screen Matting	Blue Screen Matting
Red On Black	Green On Black	Blue On Black
Red On White	Green On White	Blue On White
Black On White	White On Black	

Zoom: layer zoom function.

Zoom 



H Pos Width H Range

V Pos Height V Range

On HDMI switcher mode: could not support rotation, chroma key and layer transparency adjust.

LAYERS(HDMI SW)

Layer configuration

Zoom

Duration Cut

Layer Configuration

Layer 1 Layer 2 Layer 3 OFF ON



H Pos 0 Width 3840

V Pos 0 Height 1080

Zoom

Layer 1 Layer 2 Layer 3

Function OFF

Function ON

Reset

Match To Input

H Pos 0 Width 1920 H Range 1920

V Pos 0 Height 1080 V Range 1080

Backup mode: support automatic and manually backup, multi-machine backup synchronously, main and aux output switching support fade in/out.

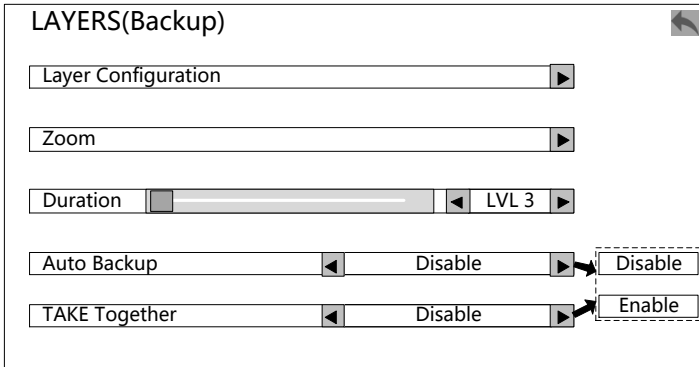

Layer configuration-select input: use to main layer and backup layer select input signals.

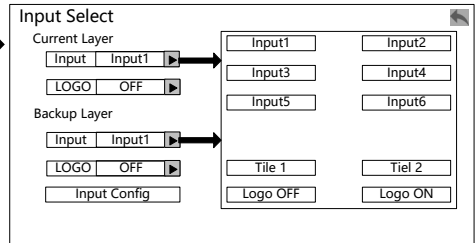
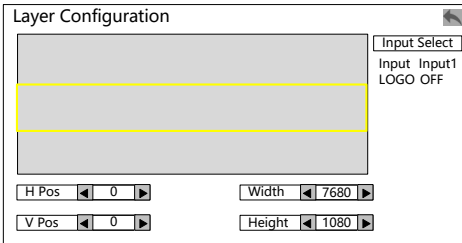

Mosaic mode/Switcher mode/Backup mode		Mosaic mode/HDMI Switcher mode/Backup mode three types working mode should switch on: output setting-working mode, different working mode has a slight different menu on “ Layers Setting ”.
		Operating open or close any layer1 to 4 and adjust the layer’s size, position, rotation directions.
	Layer configuration	Turn on/off chroma key function, and choose layer to operate buckle color, setting the range by progress bar and number key. That is, control the upper and lower limits of the Red, green, blue color, right side will display current setting, quick setting up to 14 buckle preset.
Mosaic mode	Layer parameters	Setting layer’s opaqueness,range:0~64, whenchroma key function open, opaqueness could not adjust, and after opaqueness adjusted, open chroma key function, layer would not display.
		Chroma key
		Opaqueness
	Zoom	Layer 1~4 Select the layer to operate zoom
		Function off/on Turn off/on the layer zoom function
		Reset Reset the zoom parameters
		Matching input signal According to the resolution, match corresponding vertical/horizontal datum.

		Layer zooming parameters	Adjust zooming the layer's size and datum.
	Duration		Switcher chooses the duration of layers in splicing mode, default LVL2, adjustable LVL1 and Cut (fade-in and fade-out time of single layer.
	Layer configuration		Select open or close any layer1~3,adjust the layer size and position.
HDMI Switcher mode	Zoom	Layer 1~3	Select layer to operate zoom.
		Function off/on	Turn off or turn on layer zoom function.
		Reset	Reset the parameters of the zooming layer.
		Matching input signal	According the input signal resolution,matching corresponding vertical/horizontal datum.
		Layer zooming parameters	Adjust zooming layer's size, position, datum.
		Duration	duration of preview and program default Cut, could change to LVL 1,LVL 2,LVL 3.
	Layer Configuration		Adjust layer size, position, backup and main layers size, position are always the same.
Backup	Zoom	Input select	Select the input signal to main layer and backup layer.
		Display/backup	Select the layer to operate zooming.
		Function off/on	Turn on or turn off the layer zoom function.
		Reset	Reset layers' zooming parameters
		Match input signal	According to input signal resolution, matching corresponding horizontal and

		vertical datum.
	Layer zooming parameters	Adjust layer zooming size, position, datum.
Duration	Select the main/backup input duration on the backup mode, default Cut, could choose LVL 1,LVL 2,LVL 3.	
Auto Backup	Function is enabled/disabled.	
TAKE Together	The function is enabled/disabled, and mutually backup is exclusive with automatic backup. When this function is enabled. in the same LAN, multiple W4000 support synchronous manually TAKE backup.	

Note 1: The factory default is the mosaic mode, DVI output; If other modes are required, switch in the output setting - working mode/output mode.

Note 2:In the mosaic mode, the layer supports 90° times rotation, but only rotates the display content inside the layer, the size of the layer does not change. On DVI output, the layer can only support rotation in a single output p, not across the output. For example, layer 1 spans the output DVI 1-DVI 2, and the rotation function is not available. Under HDMI output: the layer can only be rotated in half of the output port.

Note 3: Switcher mode only supports HDMI output, HDMI 2 work as preview (output has red preview indicate). HDMI1 is main output, when output resolution is 4K×1K and below, support 3 layer to 3 layer preview switch, and LAYER1 support Full roaming, LAYER2 only supports moving in the left half of the output, LAYER 3, only supports moving in the right half of the output. In 4K×2K output resolution, support 1 layer to 1 layer preview switch.

Save & Load

Save or Load

Save Preset ▶

Load Preset ▶

Delete Preset ▶

Clear All Preset ▶ →

Preset Source ◀ Program ▶

Save Preset

Mosaic

1	2	3	4	5
6	7	8	9	10
11	12	13	14	15
16	17	18	19	20

Load Preset

Mosaic

1	2	3	4	5
6	7	8	9	10
11	12	13	14	15
16	17	18	19	20

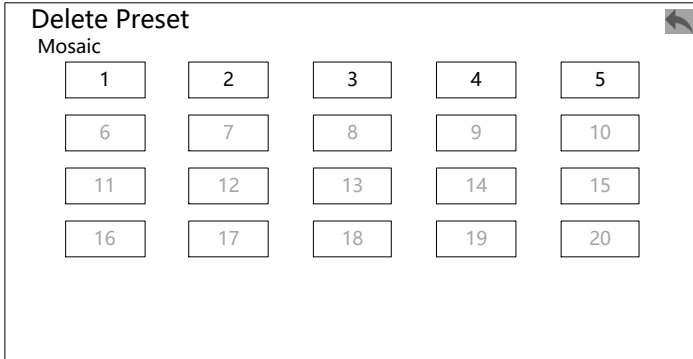

Save Preset	Mosaic mode	Shows which currently saved preset is saved in which operating mode in this processor.
	1~20	It can save 20 presets. Selecting a saved preset will prompt whether to overwrite the preset.
Load Preset	Mosaic mode	Shows which currently loaded preset is loaded in which operating mode of this processor.
	1~20	It can load 20 presets. After selecting the loading preset, a progress bar will appear above, indicating that the preset is loading until the loading is completed.
Delete Preset	Delete selecting the saved preset.	
Clear All Preset	Clear all the saved preset.	

Note 1: The font of the saved preset, number key is highlighted, while, the unsaved preset, number key is gray.

Note 2: If you want to save or load the preset, pay attention to the processor's working mode. It will only save or load the preset in the current working mode.

Note 3: Clearing the preset will clear all presets of this machine, so please use this function with caution.

Note 4: The Save Preset Channel menu will only appear on switch (HDMI) mode.

EDID setting

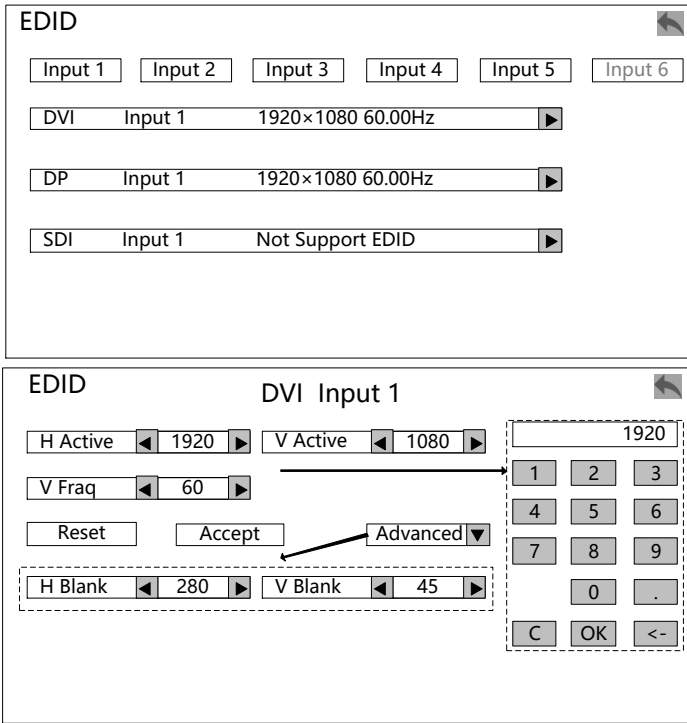

All input signals of input 1 to Input 6 can be set, except SDI. You can enter the EDID configuration detailed operation menu to set the EDID by knob selecting or input the number on touch screen.

EDID setting	DVI Input 1	Indicates the input serial number and input signal on currently EDID setting.
	H resolution	Modify the horizontal resolution of the EDID.
	V resolution	Modify the vertical resolution of the EDID.
	Reset	Reset EDID all parameters.
	Accept	Write EDID parameters to the computer graphics card.
	Advance	Advanced submenu do not adjust any parameters in the menu without the support of

our technicians. If you accidentally modify the menu, click the reset button.

H Blank Modify EDID's horizontal blank.

V Blank Modify EDID's vertical blank.

Note 1: When performing EDID configuration, the computer display mode needs to be set to the expanded mode.

Note 2: After setting the EDID, due to different computers and different graphics cards, it may need to restart the computer or plug in the signal cable. In the resolution output of the computer, select the corresponding resolution.

COMM. setting menu

Communication ↗

IP Address

Gateway

MAC

Communication setting	By modifying the IP address and gateway of the processor, it is convenient for the computer to connect to the processor through the network using the host computer.
IP Address	To display or modify the IP address of this machine, use the “knob” or “OK” button to select a number for editing, or click the edit button on the right to enter it at the lower number key.
Gateway	Display or modify the local gateway, use the knob or OK button to select the number to edit, or click the edit button on the right to enter the number below.
MAC	Shows the physical address of the machine.
Reset	Reset local IP address and gateway.
Apply	Apply modified IP address and gateway.

Note: If you want to use the computer to control the processor, you need to install the PC software to connect to the processor through the network. You can modify the IP address and gateway of the PC or the processor of the host computer so that the two devices are on the same network. The segment is the first three digits of the IP address and the last one is the same as the gateway, then the connection is successful.

MISC. menu

Misc Page: 1/2 ▲▼ ↶

Status Info	▶	Mosaic HDMI Switcher Backup FreeRun Lock To LAYER1 Genlock Enable Disable
Logo	▶	
Working Mode	◀ Mosaic ▶	
Sync Lock Setting	◀ FreeRun ▶	
Screen Touch	◀ Enable ▶	

Misc Page: 2/2 ▲▼ ↶

Date & Time	▶
Schedule & Task	▶
Factory Reset	▶

Status Info

Status Info ↶

Firmware Version	▶
Electric Info	▶

Firmware Version

MAGNIMAGE LED-W4000

Main Board: B0003 A0004 Mar 5 2019 14 : 43 : 25

UI Board : B0003 A0004 Mar 5 2019 18 : 21 : 25

Electric Info

1. voltage, (STD: 1100 mv), 1336 mv.

2. voltage, (STD: 1500 mv), 1484 mv.

3. voltage, (STD: 1000 mv), 996 mv.

4. voltage, (STD: 1200 mv), 1116 mv.

5. voltage, (STD: 12000 mv), 11146 mv.

6. voltage, (STD: 3300 mv), 3402 mv.

7. voltage, (STD: 5000 mv), 4874 mv.

Logo: This menu is slightly different in different working modes, introduce separately as below:

1. On mosaic mode

Logo

Not Saved Load

Save New Logo ▼

Layer ◀ Layer 1 ▶ Layer 4

Start Layer 3

Layer 2

Layer 1

Delete → Delete

Cancel

Logo 

LOGO Saving 3840×1080 For Mosaic

Save New Logo ▼  50%

Layer ◀ ▶

2. HDMI switcher mode

Logo 

Not Saved

Save New Logo ▼

Channel ◀ ▶

Layer ◀ ▶

Logo 

Logo Saving 3840×1080 For HDMI SW

Save New Logo ▼  50%

Channel ◀ ▶

Layer ◀ ▶

3. Backup mode

Logo 

Logo Saving 3840×1080 For Backup

Save New Logo ▼ 50%

Date & Time:

Date & Time 

Date

Time

Schedule & Task:

Schedule & Task 

Task Config

Clear Tasks

Schedule Status Stop

Task Config:

Task Select 

Mosaic

1	2	3	4	5
6	7	8	9	10
11	12	13	14	15
16	17	18	19	20

Task Config 1 

Date

Time

Frequeny

Select Preset

Task Config 1 

Date

Time

Frequeny

Select Preset

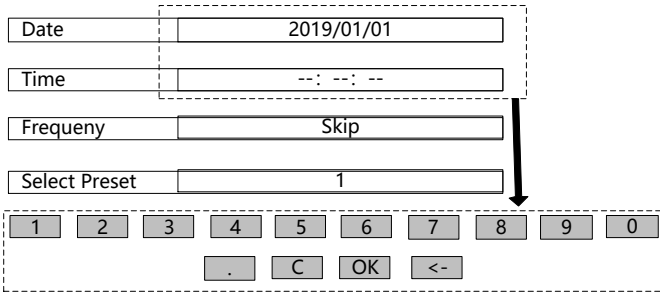

Task Config 1

Date: 2019/01/01

Time: --: --: --

Frequeny: Skip →

Select Preset: 1

Buttons: Cancel, Apply

Options (dashed box): Skip, Only Once, Every day, Period

Task Config 1

Date: 2019/01/01

Time: --: --: --

Frequeny: Skip

Select Preset: 1

Buttons: Cancel, Apply

Select Preset Grid (dashed box):

1	2	3	4
5	6	7	8
9	10	11	12
13	14	15	16
17	18	19	20

Factory Reset:

Factory Reset

Factory Resetting...
Please Wait...
↓
A.C. Restart!!!

Buttons: Cancel, Continue

Misc. setting	Set the functions of this unit.	
Status Info	Firmware Version	Displays the machine name and firmware version.
	Electrical Info	Displays the electrical status of each part of the unit.
Logo	Save and load the Logo menu, save the output image on this processor as Logo and load.	
	Not Saved	When the logo is not saved, it turn to logo menu, and it indicate logo not saved. The logo is being saved, the logo is displayed in the prompt box, also the resolution of the currently saved logo and the applicable working mode. After the logo is successfully saved, the prompt box displays that the logo has been loaded and displays the resolution of the currently saved logo and the applicable working mode.
	Save new logo	Click Save New Logo and save the new logo by following the pop-up menu.
	Start	Click " start " to start saving logo.
	Delete	Click " Delete " to delete logo.
Date & Time	Modify and show the date and time of this machine.	
	Edit	Click " Edit " button to edit the date and time of this machine.
	Restore	Restore the factory default time.
	Apply	Apply modified time.

	Date display box	Displays the current date of the unit.	
Schedule & Task		Display 20 tasks in the current working mode of the machine, click the number 1~20 task that needs to be operated to enter the task setting menu.	
	Select task		
	Date	Select the date on which the current task performs the action.	
	Time	Select the time on which the current task performs the action.	
	Task Config	Frequency	Select the frequency at the current task performs the operation: invalid, single, daily, and periodic.
		Select Preset	Select the preset of the current task execution operation, and display the 1~20 preset saved in the current working mode. The preset font bright color indicates the saved preset, and the preset font gray indicates that the preset is not saved.
	Cancel and Apply	Cancel or apply current task setting.	
Factory Reset	Restore the unit to the factory setting, and confirm that A.C. Restart!		

Note 1: The test chart will be rebuilt after each factory reset, just click to continue.

Note 2: Save Logo is the logo save in the current working mode of the processor, so please confirm whether the current working mode of the machine is correct before saving the logo.

Note 3: When you choose to save the logo, the mosaic mode saves the selected screen, the switch (HDMI) saves the selected channel and the layer, and the backup mode saves the current output. In the Layer1 screen, selecting Save Logo will overwrite the previously saved Logo.

Note 4: After clicking to start saving the logo, the machine will not be able to operate. Please wait for the logo progress bar to complete and continue with other operations.

Note 5: The choice to change the date and time is mainly for subsequent schedules and task operations.

Note 6: Schedule and task When setting tasks, the date and time setting of each task should be after the local time.

Note 7: Save the preset before setting the task.

Note 8: Restoring the factory setting will erase all setting on this processor, please use with caution.

TEST PATTERN

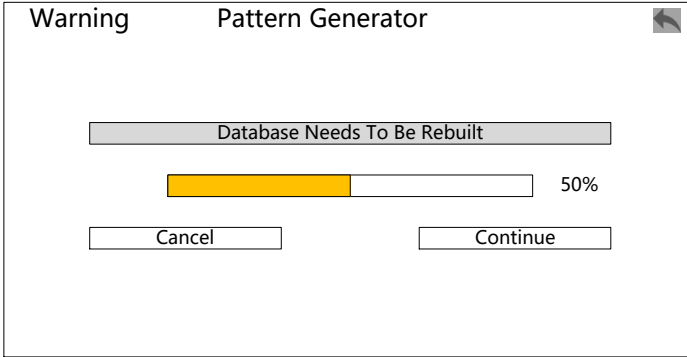
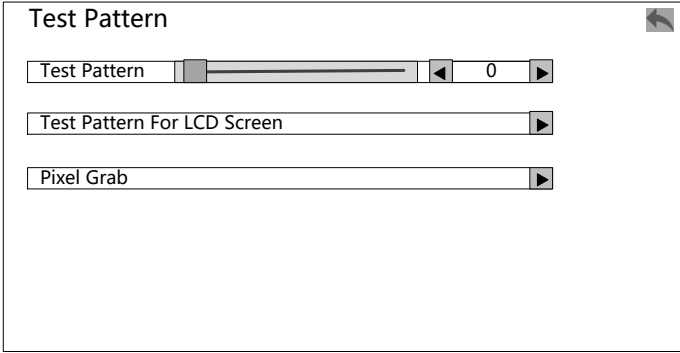

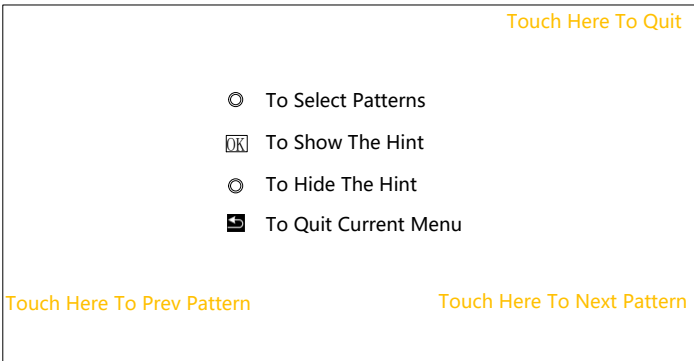

Test Pattern For LCD Screen:





Pixel Grab:

Window 



Pixel Color



H Pos  

V Pos  

Window 

Pixel Color



H Pos  



V Pos  

Capture selected pixel colors:

Window 

Pixel Color

H Pos  

V Pos  

		Output test image, easy to test all output ports and LED screen of this unit without input signal, range 0~111.
TEST PATTERN	Test Pattern	Figure card generator
		The database needs to be rebuilt.
		When after the processor factory reset, the submenu will pop up. Click Continue to use the card.
	Test Pattern For LCD Screen	Test whether the LCD panel of this unit is displayed normally, and operate it through the knob or the prompt menu on the LCD screen.
	Pixel Grab	Collect color parameters anywhere in the selected output window.

Language submenu



English	Set the display language of the menu system to English.
简体中文 Simplified Chinese	Set the display language of the menu system to simplified Chinese.
繁體中文 Traditional Chinese	Set the display language of the menu system to traditional Chinese.

Quick Use Instructions

The rear panel introduction

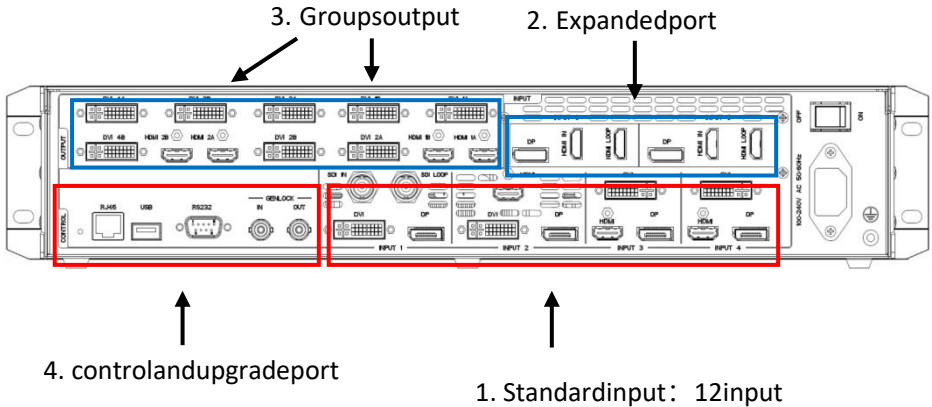

Input area port:

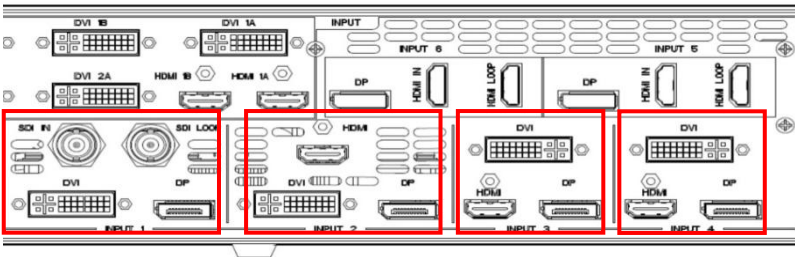

Standard input port (red line part): 12 channels, divided into 4 groups, each group of 3 signals, choose one of three to use each time; Total SDI ×1, HDMI×3, DVI×4, DP×4.

Resolution specifications: SDI (3G SDI: 1080P/i and below). HDMI, DVI, DP support 4K×1K/60Hz range EDID. Expanded input (red box): maximum supports 2 4K×2K/60Hz input boards, supports

EDID. DP supports 8K×1K/60Hz; single module includes DP×1, HDMI×1 (including 1 LOOP), Single input boards, choose one of two port to use.

Output area port:

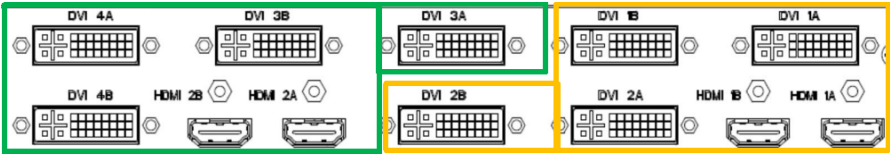

Output port: 12 channel, divide into 2 groups

First group: HDMI1A/1B、DVI1A/1B、DVI2A/2B

Second group: HDMI1A/1B、DVI1A/1B、DVI2A/2B

DVI, HDMI alternative one of two to use each time.

Control area:

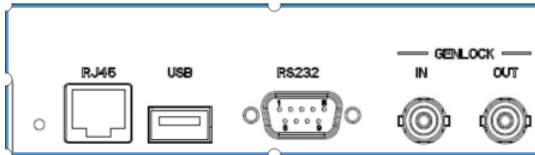

Interface: RJ45 network × 1, USB upgrade × 1, RS232 interface × 1, Genlock IN/ OUT each. Supports front panel buttons and knobs, touch screen, PC software control.

The front panel introduction

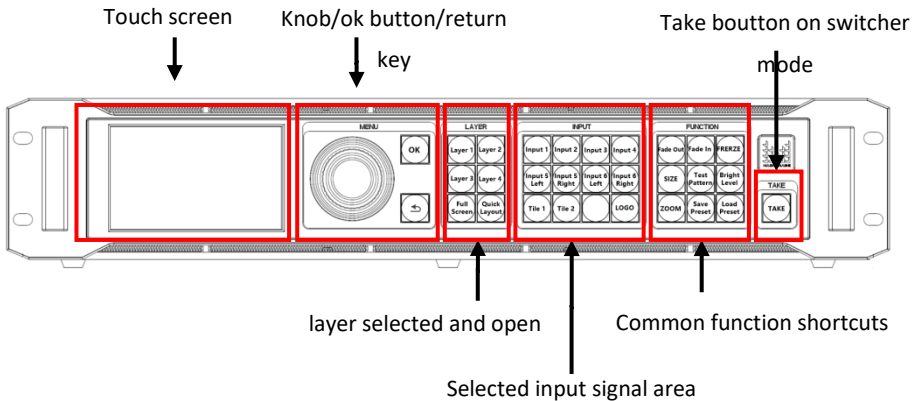

Touch screen: To prevent parameter confusion caused by accidental touch, the outermost standby interface is unavailable on. Entering any menu to continue use.

MENU area: The knob is used to select individual menu options and to enter menus, select or confirm an option. The "OK" button is used to enter the menu and select an option. Below "OK" is the return button, short press to return to the previous interface, long press for 3 seconds to return to the standby interface.

LAYER area: Layer 1/Layer 2/Layer 3/Layer 4: Corresponding to the four layers of the device, short press to select the layer, long press for about 3 seconds to open or close the layer.

FULL SCREEN: Allows the currently selected layer to be full-screen in one button in the corresponding output area.

QUICK LAYOUT: No function defined yet.

INPUT area: Input 1/Input 2/Input 3/Input 4 is equipped with four groups of signal selection buttons. INPUT 5 and INPUT 6 are two groups of expanded input selection. When these two groups of

inputs are 4K×2K@60Hz, the signal input It is divided into left and right processing, corresponding to Input 5 Left/Input 5 Right/Input 6 Left/Input 6 Right; (Input 1-4 does not divide left and right).

TILE: Combination signal selection button, up to two signal combination keys, corresponding to Tile 1 and Tile 2.

INPUT MUX: Quickly enter the “**Input Signal Information** →”**Input MUX Config**” menu interface.

LOGO: Call out logo button.

Signal selection method: First select a layer (layer1-4), then select an input signal.

FUNCTION area: Fade Out & Fade In: fade-out and fade-in. buttons of the currently selected layer. It can be used with the Tile button to set the fade-in and fade-out setting for multiple signals.

FREEZE: The button to freeze overall output image.

SIZE: Layer size and position adjustment interface shortcuts.

TEST PATTERN: Test chart shortcut.

BRIGHT LEVEL: Output brightness level shortcuts.

ZOOM: Output layer zoom shortcut.

SAVE PRESET: Save template shortcut.

LOAD PRESET: Load template shortcut.

TAKE: A switch key on switcher mode/backup mode.

Input signal information, TILE function introduction

1. Input Signal Information

Set one of the signals in each group of inputs to be used as input (three inputs per group, choose three for one to use).

Select the "Input Signal Information" menu:

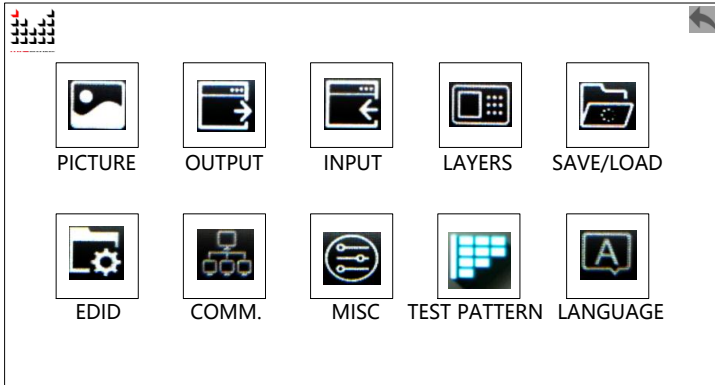

Enter the "Input MUX Config" menu option to configure the input signal.

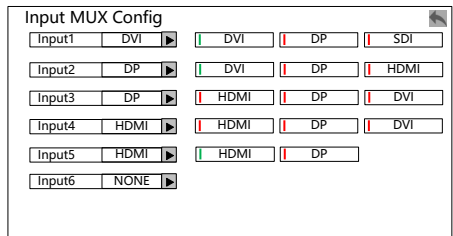
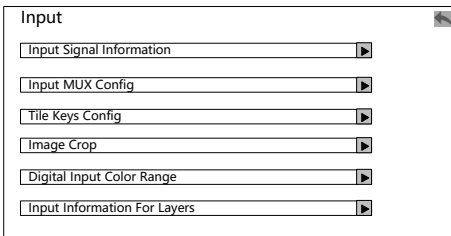

Set one of the signals in each group as input, or press the "INPUT MUX" button on the front panel to enter the menu.

2. TILE function introduction

Multiple input sources can be spliced into one unit at the input port as a combined signal source. For example, the graphics card 3 DVI horizontal splicing output to the W4000, through Tile function, it can make a 3 DVI signal into a tile, which is convenient for unified calling and zooming. Like 3 input signals, 4 output, more convenient to use, no need to consider output aliquot/unequal load relationship.

TILE Keys Config

TILE 1 Input 1 + Input2... Edit

TILE 2 Undefined! Edit

Input 1 DVI 1920×1080 Input 2 DP No Signal

Input 3 DP No Signal Input 4 HDMI No Signal

Input 5 HDMI 4096×2160 Input 6 None

Clear Cancel Apply

Note:

1. In the mosaic mode and backup mode, support 4 channels of 2K×1K, 2 channels of 4K×1K input signals are combined into a tile.
2. In switch mode, support 2 channels of 2K×1K range input signals to be combined into one tile.
3. Only sources with the same resolution specifications can be combined into a Tile.
4. TILE only supports horizontal tiling.

Working mode introduction

This processor has three working modes: Mosaic mode, Switcher (HDMI) mode, and Backup mode.

Two output modes: DVI and HDMI, only HDMI output is supported on Switcher mode.

Mosaic mode function

1. Enter “**Output setting**” in the main menu, select the Mosaic mode, use DVI or HDMI output, and output resolution of single output port.

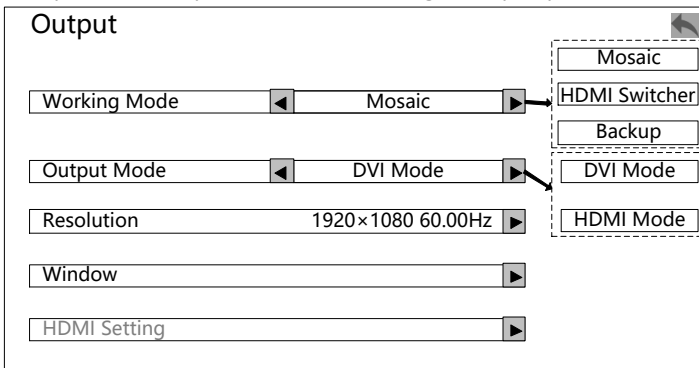

2. Enter “**Window**” menu: set the actual pixel loaded on each output port and the mosaic method of the output port.

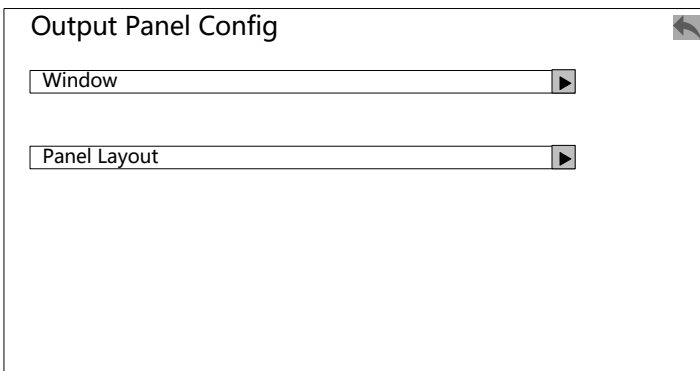

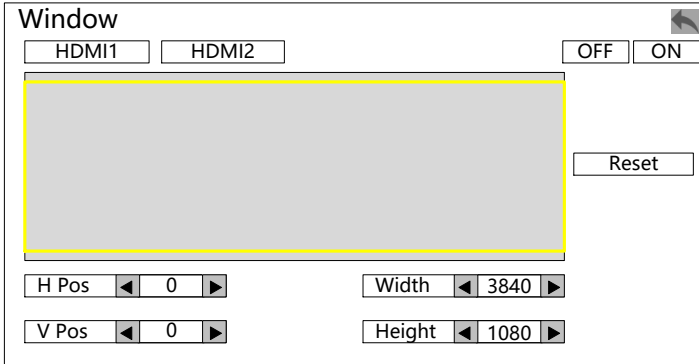

The output port can be arranged horizontally, vertically, and 4 identical squares (on DVI output).

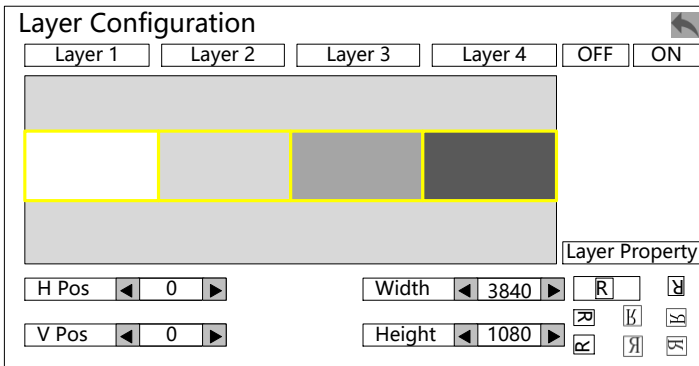

3. Enter the "LAYERS setting" menu, select "Layer Quick setting".

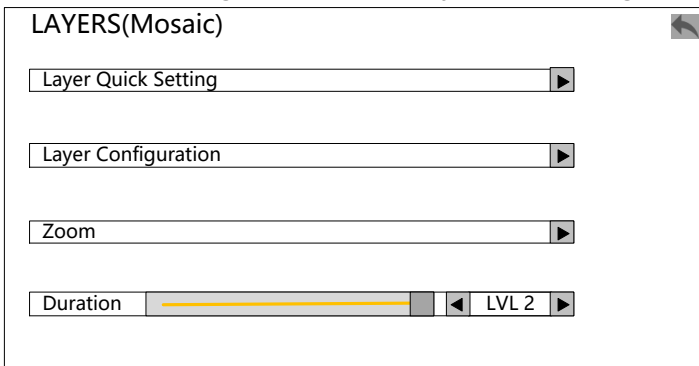

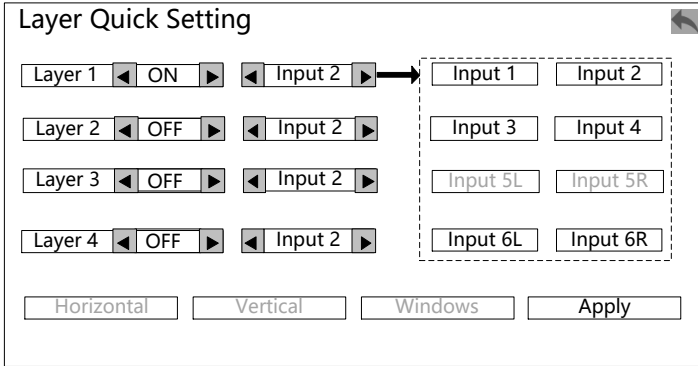

Choose which layers to use, which input to use in each layer, and how to automatically mosaic to the output (horizontal, vertical, or 4 identical squares layout).

The LED-W4000 output each layer is independent. By setting the size of the output window and the layout of the output to matches the actual load.

Through the “**Layer quick setting**”, multiple inputs can be quickly spliced and spread to the entire output, thus realizing the processor “2 input, 3 output splicing”, “3 input, 4 output splicing”, “4 input, 4 output splicing” etc. the method of use is more flexible than the traditional processor.

Switcher function

1. Switcher mode setting: Select "HDMI Switcher" working mode (Switcher mode, only HDMI has output), on the main menu "Function Options". HDMI 1 A / B is the main output, HDMI 2 A / B is preview (with preview indicate).

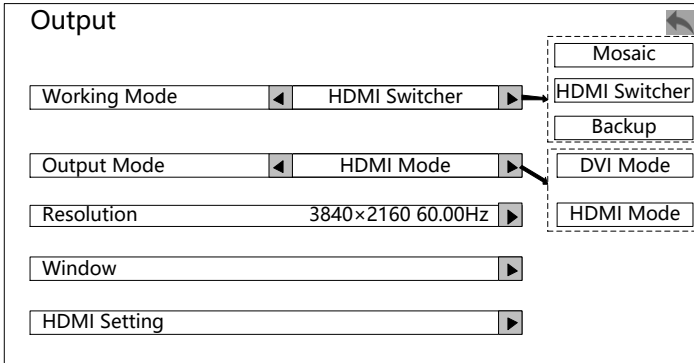

2. Enter "Layers Setting" menu and select "Layer Configuration", or directly press the "SIZE" button to enter this operation interface and adjust the size of each layer.

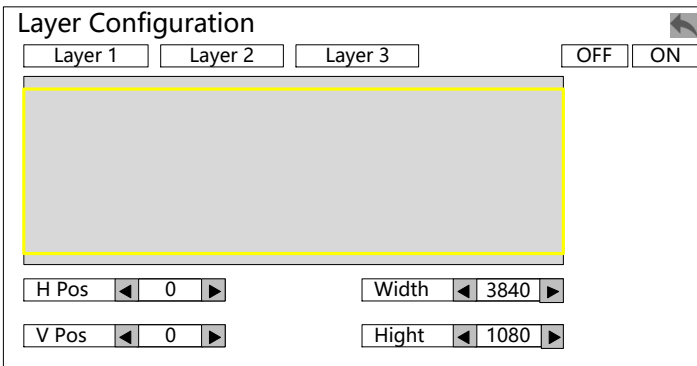

Note:

- If using 4K output resolution, please use 4K display monitor as preview-monitoring display.
- In 4K×1K and below output resolution, support 3 layer to 3 layer preview switching, and LAYER 1 supports full roaming, LAYER 2 only supports moving

in the left half of the output, LAYER 3 only supports the right half of the output.

C. In 4K×2K output resolution, support 1 layer to 1 layer preview switch.

D. In the switch mode, the output window size cannot be adjusted.

3. Preset save and load: Press the front button “**SAVE PRESET**” and “**LOAD PRESET**” to display the following menus respectively. You can save/load the corresponding preset through the knob and “**OK**” button. Use the “**TAKE**” button to switch between main output and preview.

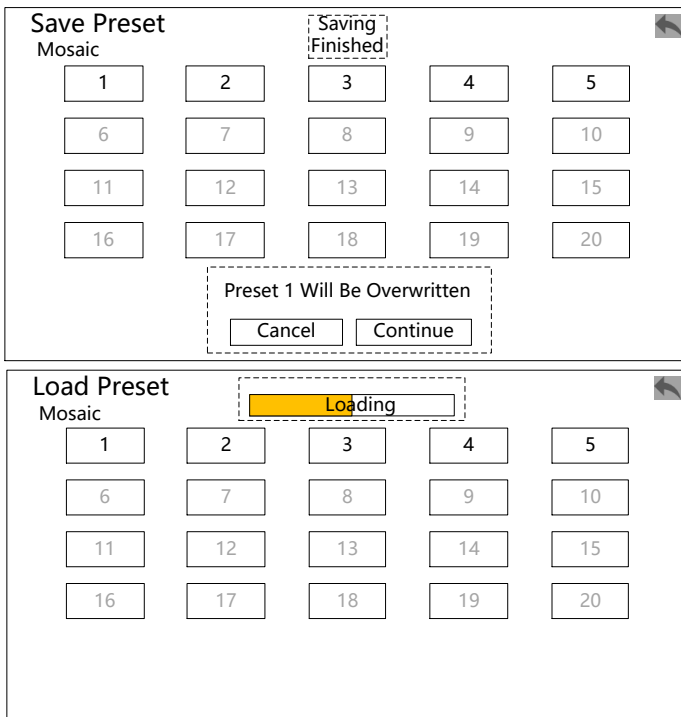

Note:

A. The preset channel is Preview or Program. You can modify this option in the main menu “**SAVE/LOAD**”.

B. After loading the preset, it will call out Preview, use TAKE button to switch between main output and preview.

C. Support MIG-EXK 200 keyboard, with W4000 host computer software,

make preset load and switch operations.

D. Saved presets, the number key is highlighted.

4. Duration, there are "CUT" and "LEVEL1-3" optional.

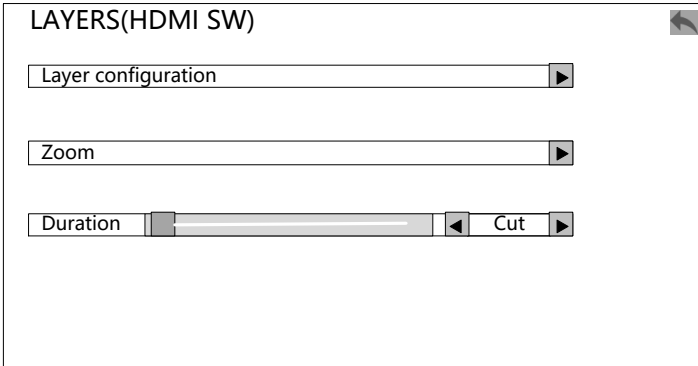

Backup mode function introduction

1. Enter “**OUTPUT Setting**” in the main menu, select Backup mode, use DVI or HDMI output, and output resolution of single output port.

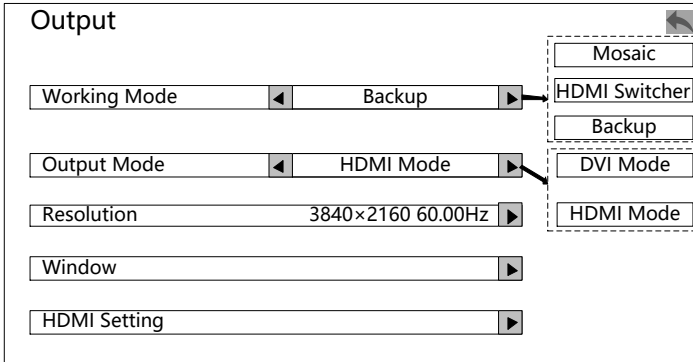

2. Adjust the “**Window**” menu: set the actual pixel loaded on each output port and the mosaic mode of the output port (refer to the setting method in the mosaic mode).

3. Enter “**Layers Setting**” - “**Layer Configuration**” in the main menu, or directly press the “**SIZE**” button to enter this operation interface and adjust the size of the layer.

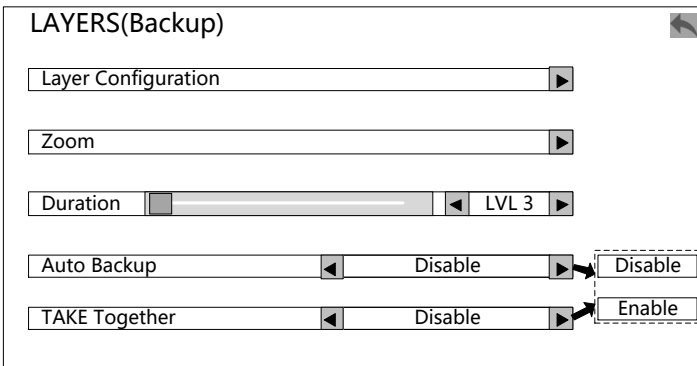

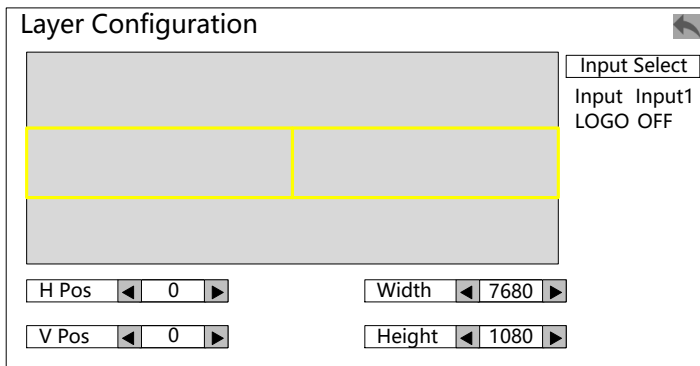

Note:

1. On Backup mode, only layer1 and layer 2 can be used, and the layer size/position is always the same.
2. Pay attention to the processor LCD panel prompt, the default layer1 is the main display, layer2 is the backup, when TAKE is switched, layer2 is the main display, layer1 is the backup, the main display layer is always at the top, backup is at the bottom.
3. Automatic backup is disabled by default. When this function is enabled, if W4000 detects that the input signal of the main display layer is lost, it will automatically switch to backup.
4. Support backup switching between single input source or tile input.
5. Multi-machine TAKE and automatic backup function are mutually exclusive items, can only be used one by two; After the multi-machine TAKE function is turned on, press one of the TAKE keys, and multiple W4000s in the same LAN can be switched synchronously.

Warranty Description

Machine warranty

- 24 months from the date of purchase of the user's invoice.
- If the user purchase invoice is lost, the 60 days after the production date will be the warranty start date for the product.

Non-warranty

- The machine soaking and collisions produced besmirch or surface scratches and other abnormal using causes of malfunction or damage.
- Demolition machine or modification, which is not to be agreed by our company.
- Using in the not specified used working conditions, resulting in fault or damage (such as high temperature, low voltage or unstable etc.).
- Force majeure (such as fire, earthquake, etc.), or natural disasters (like lightning, etc.) caused the fault or damage.
- The product is out of warranty.