

SET-UP GUIDE FOR

# M2 AUTOMATED CUTTING MACHINE

A guide to assembling your MakerMade M2 CNC Kit.

 **makermade**

v 2.6 Updated 12.6.21 ©Maker Made, LLC

# TABLE OF CONTENTS

**SECTION 1. Intro - 3**

**SECTION 2. Parts Needed - 4**

**SECTION 3. What's in the box? - 5**

**SECTION 4. Assembling the M2 - 7**

**SECTION 5. Attaching your router - 14**

**SECTION 6. Tips and safety warnings - 15**



# INTRODUCTION



Thanks for buying the M2 CNC Automated Cutting Machine, welcome to the MakerMade family! The following instructions are intended for beginners - with no prior CNC experience.

Here are some notes on the layout...

1. Setting up the M2 can be broken down into three main parts: building the M2, building the frame (or mounting it on an existing Maslow frame), and calibration. This guide covers building the M2.

2. I'm Drew and I made this guide! My notes are tips and tricks to help you along. They are in a different blue font and look like this:

**Drew's Note:** Let us know how this guide can be improved for beginners. We love to hear from you!

They are meant to answer some of the “why” questions you might have and give you tips to get started. We suggest printing the guide in color, if you want a paper copy.

3. Each step contains written instructions, a visual rendering of those instructions, color coded pictures of **sub-steps** or **parts needed** for that step, and the hardware bag where you'll find the parts you'll need.



Here's me and Spaghetti, he's not impressed with CNC



Like this Bag G in orange

# PARTS NEEDED

## Tools needed for building and operating your M2 (that didn't come with your kit):

Router  
13mm Combo Wrench (or any adjustable wrench)  
Phillips Screwdriver/ drill  
Tape Measure/Digital Caliper  
Two Standard Sized Bricks (to that attach to the M2 for weight during operation)  
Dust Collection System

Drew's Note: Check out the [M2 Video Playlist](#) for an overview of what's in the box and other how to-videos!

You'll have to supply your own router for your M2. Here is the recommended list:

Router	Clamp Size	MakerMade Tested	Community Tested
Bosch Colt 1hp (PR20EVSK)	71mm (included with M2)	Yes	Yes
Bosch 2.25hp (1617EVS)	91mm (included in M2 Upgrade Kit)	Yes	Yes
DeWalt 611 1.25hp (DWP611)	71mm (included with M2)	Recommended	Yes
DeWalt 618 2.25 (DW618M)	91mm (included in M2 Upgrade Kit)	Yes	Yes
Makita 1.25hp (RT0701C)	71mm (with 3D printed adapter)	Yes	Yes
Ridgid 2hp (R2202)	91mm (included in M2 Upgrade Kit)	Yes	Yes
Ridgid 2hp (R22002)	91mm (included in M2 Upgrade Kit)	Yes	Yes













The following is what came in your M2 CNC kit!



# WHAT'S IN THE BOX?

<p><b>DUE v1.2 Control Board, Shield, and Case</b></p> 	<p><b>10' MicroUSB to USB cord</b></p> 	<p><b>AC/DC Power Adapter and cord</b></p> 	<p><b>X, Y, and Z Axis Motors (3)</b></p> 
<p><b>X, Y, and Z Motor Power Cables</b></p> 	<p><b>Motor Mounting Brackets (2)</b></p> 	<p><b>Stud Mounts (4)</b></p> 	<p><b>Ring Carriage</b></p> 
<p><b>Roller Bearing Carriages (2)</b></p> 	<p><b>Z-Axis Mount L-Brackets (3)</b></p> 	<p><b>Z-Axis Assembly</b></p> 	<p><b>Sled</b></p> 
<p><b>Router Clamp</b></p> 	<p><b>Roller Bearings (4)</b></p> 	<p><b>Chains 335cm/11' (2)</b></p> 	<p><b>Dust Collection Bracket</b></p> 
<p><b>Spring</b></p> 	<p><b>MakerMade Router Bit Starter Set</b></p> 	<p><b>Velcro Dust Collection and Brick Mounting Straps (3)</b></p> 	<p><b>Acrylic Dust Cover</b></p> 



<p><b>MakerMade USB</b></p> 	<p><b>Marker</b></p> 	<p><b>Stickers, Quick Start Guide, and Welcome Letters</b></p> 	<p><b>Chain Mounting Hardware Bag A</b></p> <p><b>Cotter pins (2)</b>  <b>Chain sprocket (2)</b>  <b>Small nails (2)</b>  <b>Large nails (2)</b>  <b>White spacers (2)</b></p> 
<p><b>Spring Hardware Bag B</b></p> <p><b>Quick links (2)</b>  <b>Small screws (4)</b>  <b>Zip ties</b></p> 	<p><b>Short/Long Frame Mounting Screws Bag C</b></p> <p><b>Black wood screws</b>  <b>Silver wood screws</b></p> 	<p><b>Short/Long Frame Mounting Screws Bag D</b></p> <p><b>Black wood screws</b>  <b>Silver wood screws</b></p> 	<p><b>X/Y Motor Hardware Bag E</b></p> <p><b>Motor sprocket (2)</b>  <b>Grub Screws (2)</b>  <b>Motor screws (8)</b>  <b>Motor washers (8)</b></p> 
<p><b>Bearing Carriage Hardware Bag F</b></p> <p><b>Shoulder bolt (4)</b>  <b>Large washer (8)</b>  <b>Large locking nut (4)</b></p> 	<p><b>Ring and L-Bracket Hardware Bag G</b></p> <p><b>Tiny wood screws (20)</b>  <b>Small black M3 bolts (12)</b>  <b>Locking nuts (12)</b></p> 	<p><b>Assembly Tools Bag I</b></p> <p><b>5mm hex wrench</b>  <b>4mm hex wrench</b>  <b>3mm hex wrench</b></p> 	<p><b>Z Axis Hardware Bag C</b></p> <p><b>Z Motor bracket</b>  <b>2.5mm and 2mm hex wrenches</b>  <b>Flat combo wrench</b>  <b>Belt, Black M3 x 8mm bolts (6), Large gear</b>  <b>Small gear</b>  <b>Large set screws (2)</b>  <b>Small set screws (2)</b>  <b>M4 x 8mm bolts (4)</b>  <b>M4 Locking nuts (4)</b>  <b>M5 x 8mm bolts (8)</b>  <b>M5 T-nuts (8)</b></p> 

# ASSEMBLING YOUR M2

The M2 kit comes in several pieces to assemble.

Drew's Note: We recommend reading this entire section before beginning assembly.

Check out [this](#) video playlist on how to build the M2!

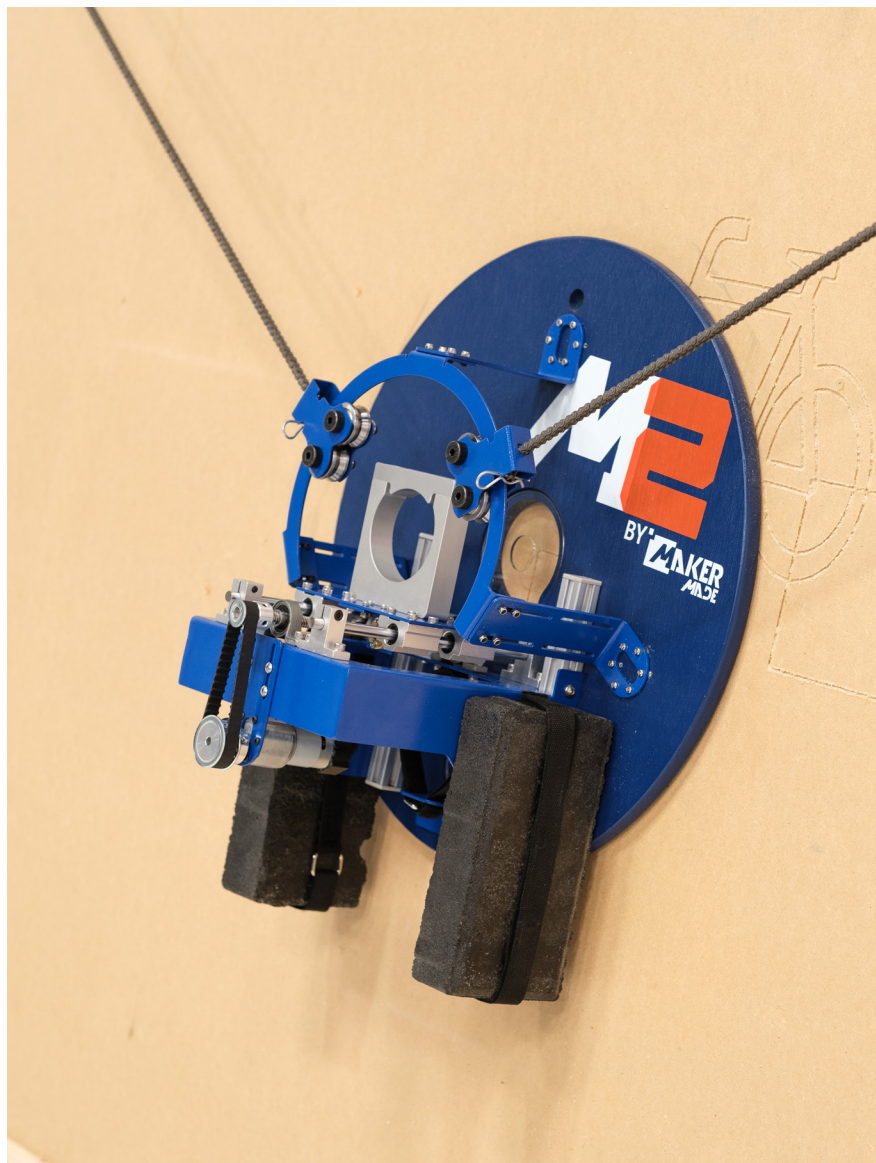

1. There are three sets of countersunk pilot holes in the sled. Place the **ring carriage** in the center and align with the pilot holes. Align the L-brackets with the ring bracket attachment on each set of holes, with the tall sides toward the center. Screw the aligned **L-brackets** into the sled, oriented with the ring carriage, using a **Phillips screwdriver** and the tiny **silver screws**.



Ring and L-Bracket  
Hardware Bag G

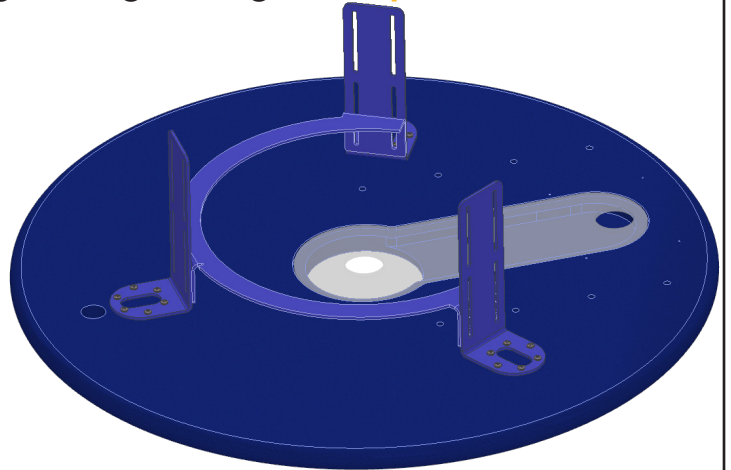

Drew's Note: We will use the last two tiny screws in step 16, so don't lose them!

2. Attach the three L-brackets to the rectangular brackets on the ring carriage using four small **black bolts and locking nuts** on each bracket. Use the smallest (**2mm**) **hex wrench** on one side and the **flat wrench** on the other.



Ring and  
L- Bracket  
Hardware Bag G



Z Axis  
Bag C

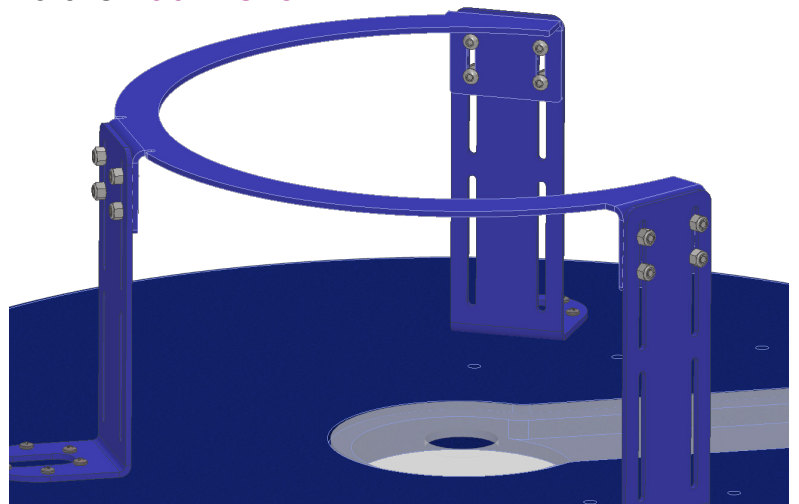

Drew's Note: The ring carriage is adjustable for the thickness of the material you're cutting! For now, we'll attach it at the top.

3. Hang a **roller bearing carriage** on each side of attached ring carriage.



Roller bearing carriages

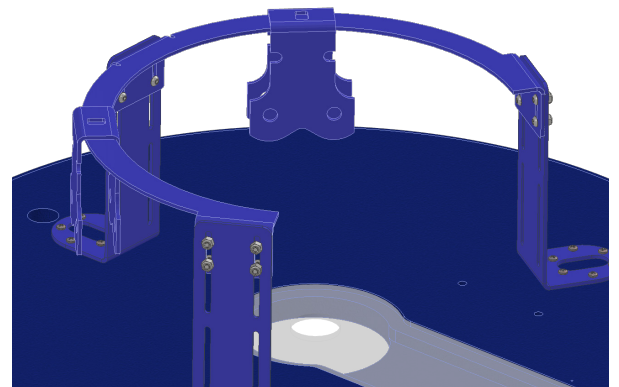



4. Assemble both roller bearing carriages by inserting the shoulder bolt through larger carriage hole, then through a washer, the **ring bearing**, another washer, and out through the smaller side of the roller bearing carriage. Use the largest **(5mm) hex wrench** on one end and 13mm combo wrench (or any **wrench**) on the other to tighten.



Bearing Carriage Hardware Bag F



Assembly Tools Bag I

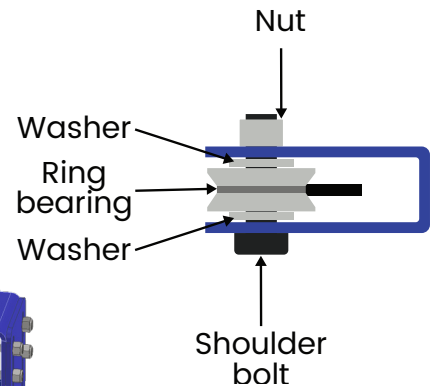
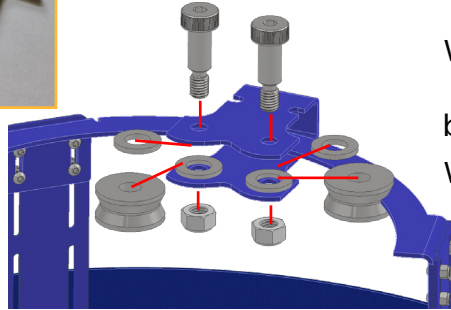

5. Remove the protective plastic on each side of the **acrylic dust cover**. Then place it over the dust collection slot.



Acrylic dust cover

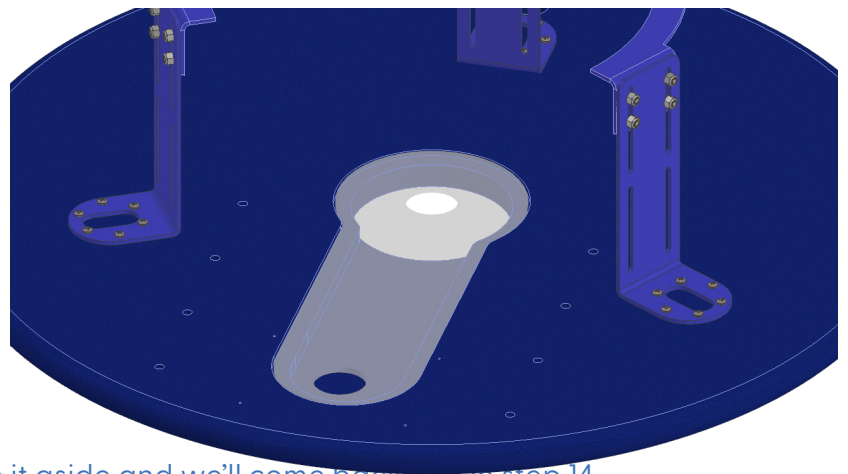

Drew's Note: The sled assembly is done! Place it aside and we'll come back to it in step 14.

6. Attach the Z motor (from the motor box) to the **Z motor bracket**. Align the motor shaft in the slot closest to the end of the bracket. Use the small **black bolts** and the **2mm hex wrench**.



Z Axis Bag C



Z motor bracket

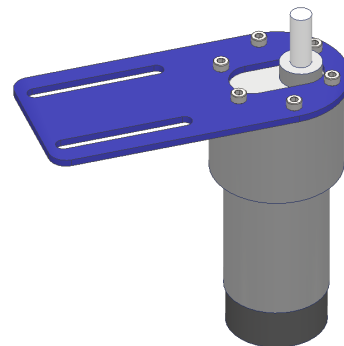

7. Attach the **large gear** to the motor, just above shaft base, ensuring one large set screw is on the flat side of motor shaft. Attach with the two large **set screws** using the second smallest (**2.5mm**) **hex wrench**.



Z Axis  
Bag C

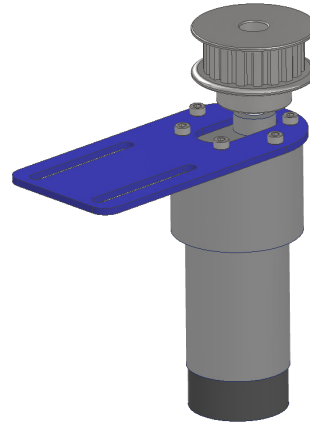
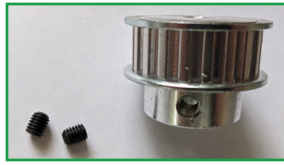

8. Attach the **small Z axis gear** on the **Z axis assembly's** lead screw, with the top of lead screw about 1/4in (6mm) beneath the top edge of the gear. Tighten it using the two smaller **set screws** and the **2mm hex wrench**.



Z Axis  
Bag C

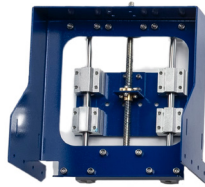

Z axis  
assembly

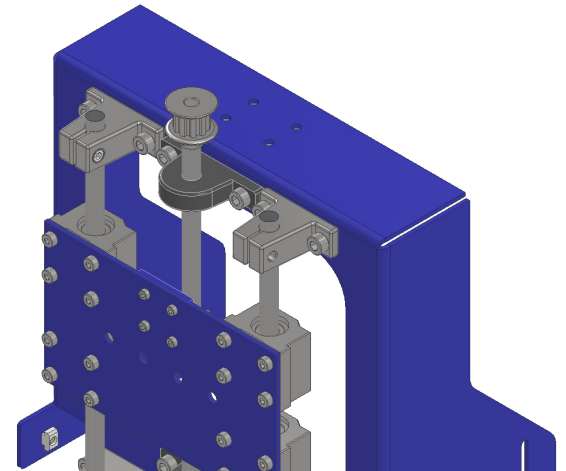

9. **(A)** Loop one end of the **belt** around large gear. **(B)** Loop the other end around the top of the small Z axis gear. **(C)** Using the Z axis assembly as leverage, push the bracket down until it is flat and parallel with the top of the Z axis assembly. This will ensure the belt is tight.



Z Axis  
Bag C



**(A)**

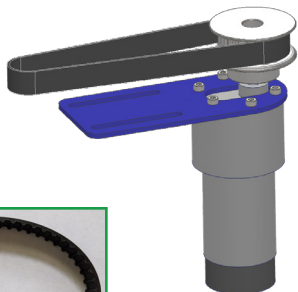

**(B)**

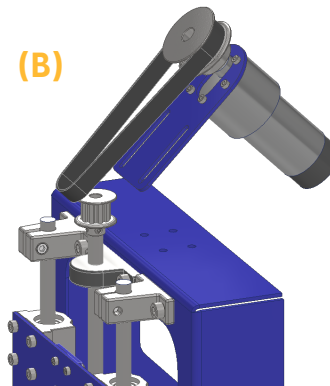

**(C)**

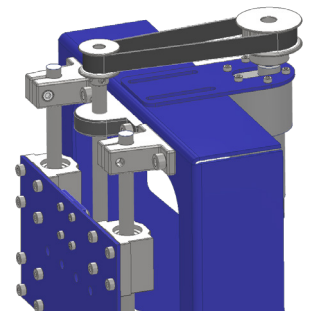

10. Attach the Z motor bracket to the Z axis assembly using the four **silver bolts** and **locking nuts**. Hold the nut with the **flat wrench** and tighten from the top using the **2.5mm hex wrench**.



Z Axis  
Bag C

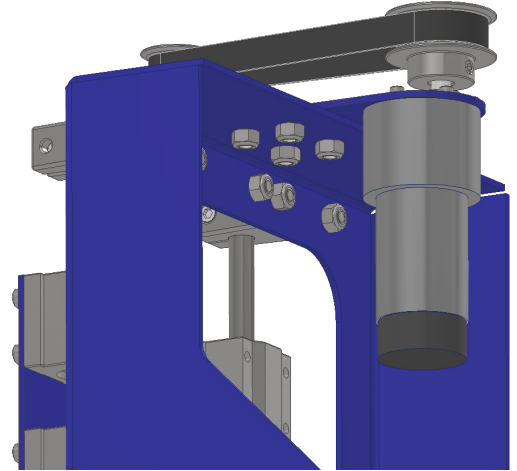

11. Ensure that the gears are level, with the belt between them. If they are not level, loosen the set screws on the gear that is taller, and push it down until it is level with the other gear. Re-tighten the grub screws at the new height.

Drew's Note: Be sure that your belt is tight and level between the gears! If the belt is loose or not level, the Z axis on your M2 will not move properly.

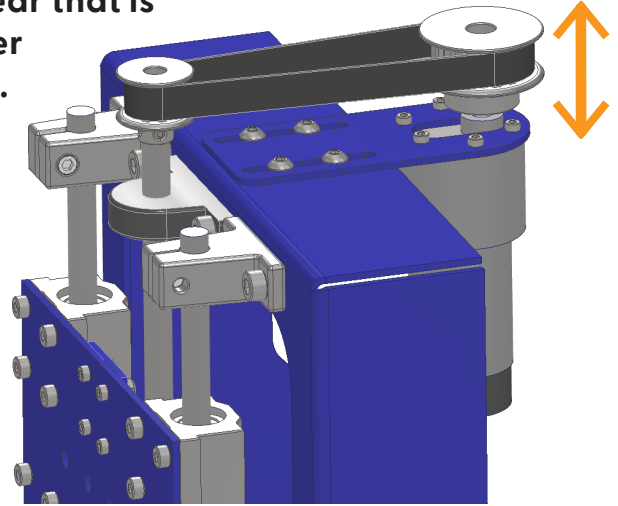

12. Attach the **router clamp** to the Z axis assembly using the bolts that are screwed into the clamp. Unscrew them and attach the clamp to the Z axis assembly as shown with **3mm hex wrench**.



Assembly Tools  
Bag I



Router clamp

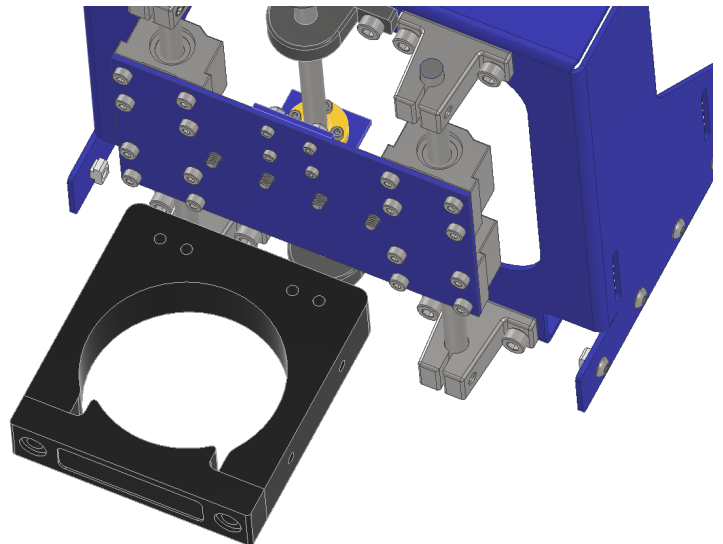

13. Insert the eight **bolts** into the holes from the outside of the base of the **left** and **right** sides of the Z axis assembly. From the inside of the z-axis assembly, hand tighten the **T-nuts** half-way onto the bolts.



Z Axis  
Bag C

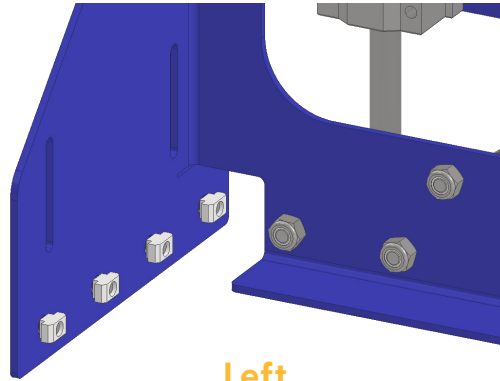

Left  
side

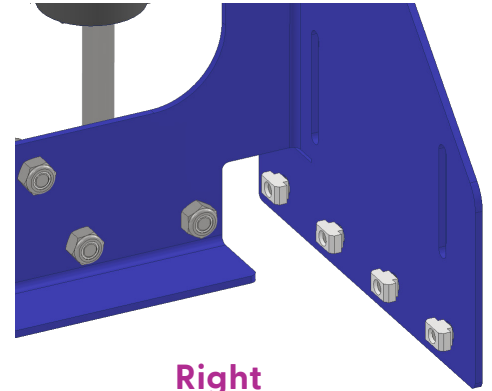

Right  
side

Drew's Note: The Z axis assembly attaches to the sled with T-nuts. They are marvels of engineering that are specially designed to hold different materials together. Some even turn sideways (perpendicular) when they are tightened! Ours fastens the z axis assembly to the aluminum extrusion rails "feet" that are attached to the sled.

Check out this T-nut  
x-ray coolness!

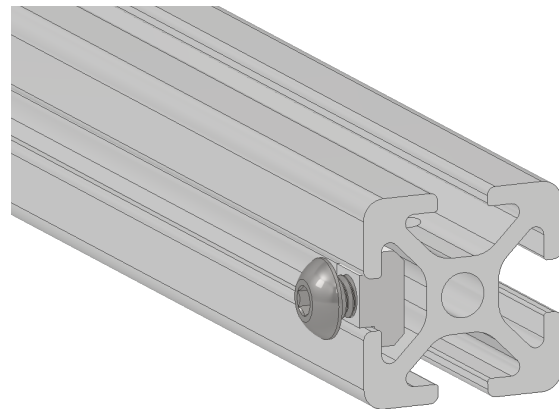

14. **(A)** If attached, pop the caps off the ends of the sled rails. **(B)** Rotate the T-nuts, so they are parallel with the inside of the sled rails. **(C)** Slide the Z-axis assembly onto the rails, with the T-nuts sliding into the slots on the outside of the rails. Stop when the router clamp is centered with the center sled hole.

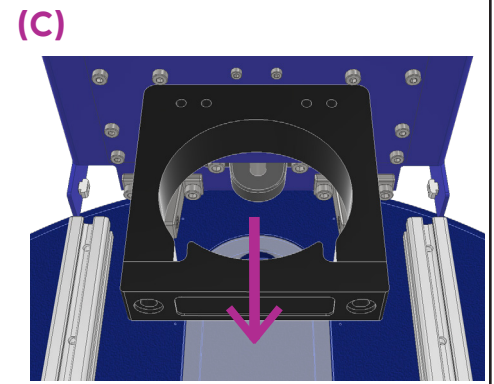
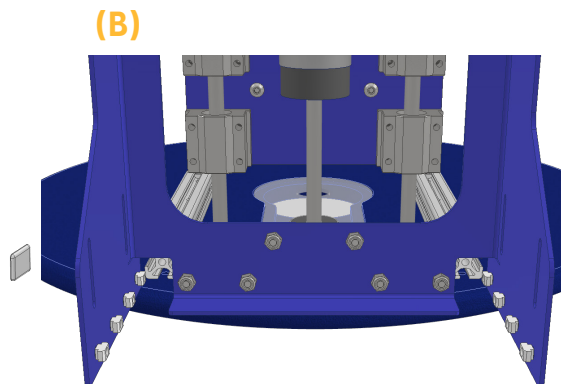
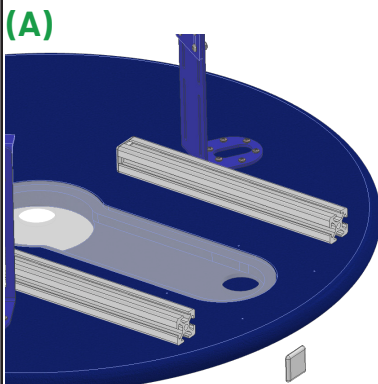



15. (A) Tighten the T-nuts using the 3mm hex wrench. The z axis assembly should be securely attached and not move or wiggle on the rails. (B) Replace the end caps on the Z Axis.

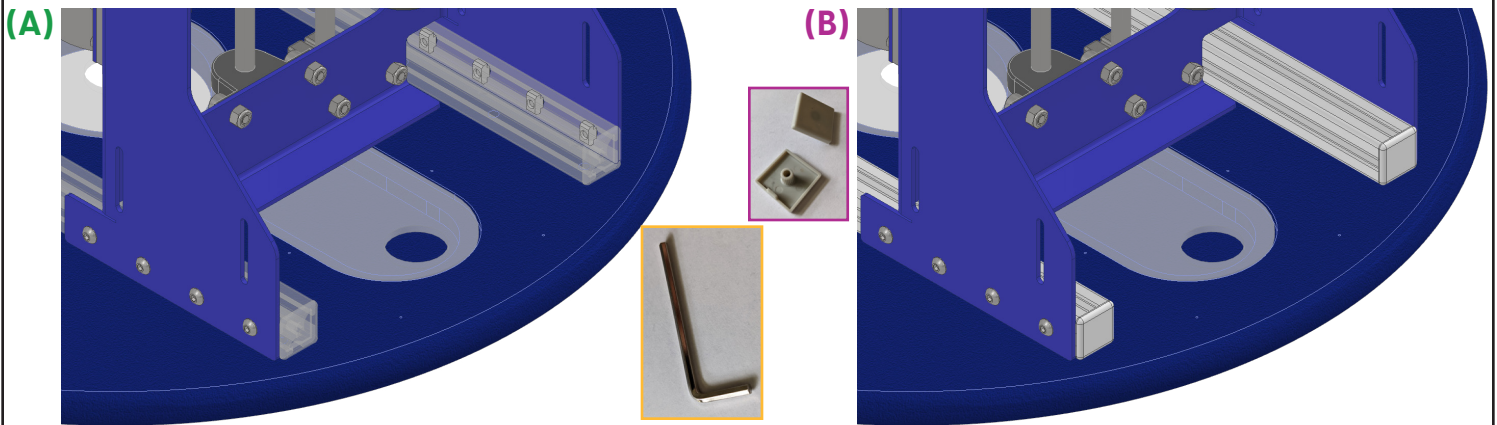

16. Attach the dust hose bracket in the best orientation for your particular dust hose, using the two tiny screws leftover from step 1 (from the Ring and L-Bracket Hardware Bag). (A) For hoses smaller than 2" (51mm) in diameter, attach the bracket closer to the sled edge, aligned with the pre-drilled pilot holes. (B) For larger diameter hoses, attach the bracket against the Z axis assembly.

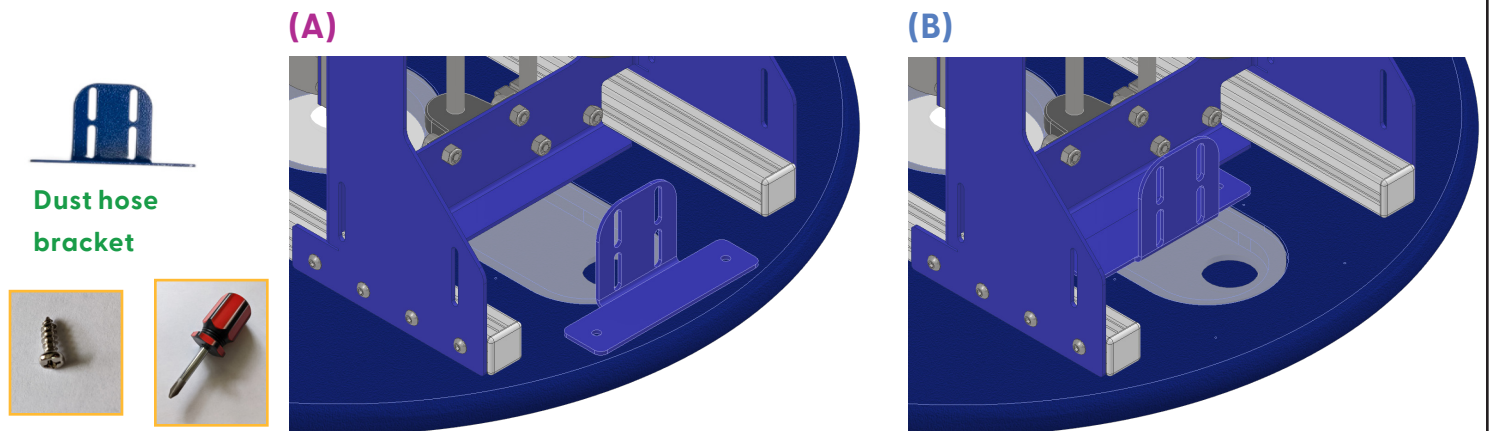

17. (A) Attach the black or orange, shorter Velcro dust collection strap to the dust hose bracket. (B) Loop the two longer Velcro brick straps by feeding them through the slots on the sides of the Z axis assembly. You'll attach the bricks (and cinch them tight) after you mount your M2 to your frame.

Drew's Note: The M2 needs about 8-10lbs (4kg) of weight to move properly and safely keep the bit held to your material using gravity. That's why we use two bricks!

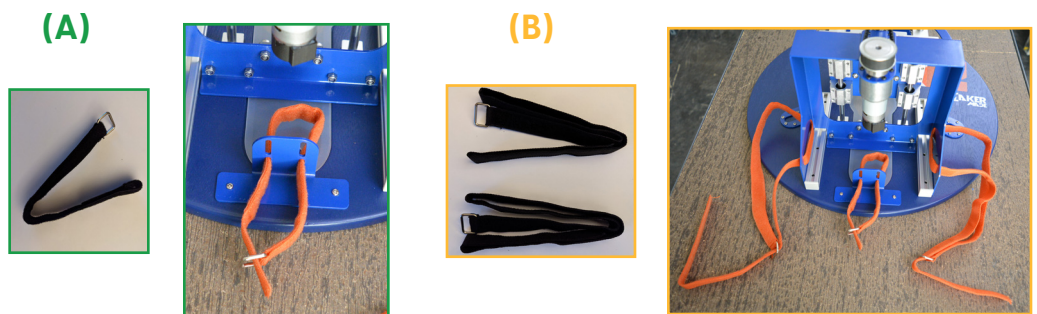

# ATTACHING YOUR ROUTER (NOT INCLUDED)

18. Loosen the hex nuts on the front of the router clamp using the **3mm hex wrench**. Attach a router bit to your router and insert it into the router clamp. Tighten the clamp. The bit should be just above touching the surface of the table that you're building your M2 on, about 1/4" (6mm) up.



Drew's Note: You can adjust your router up or down in the clamp later to accommodate for large adjustments to how deep you can cut into your material.

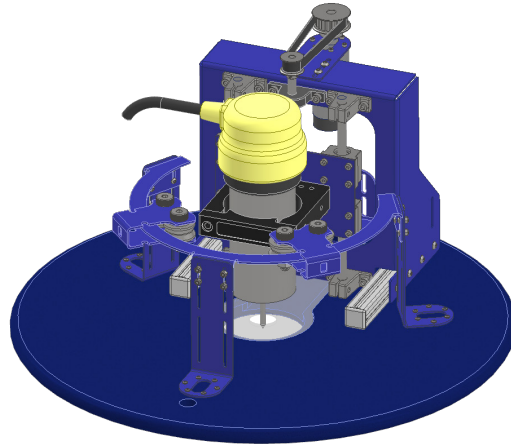

16. Align the bit to the **center** of the center sled hole. The easiest way to align is by sliding the Z-Axis assembly forward or backward until the distance is exactly the same from the bit to each edge of the front and the back of the dust collection hole.

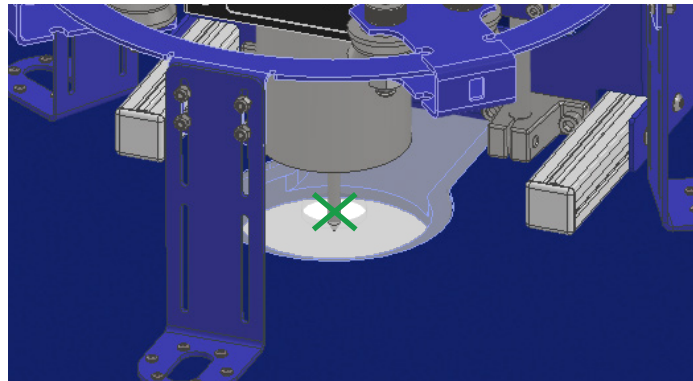

Drew's Note: It's very important that the router bit is in the exact center of M2 sled hole! All of the triangulation math for the M2's GRBL code is based off the assumption that your bit is in the exact center. If it is off, even by a few millimeters, it will result in your M2 cutting incorrectly.

# APPENDIX - TIPS

[Click here to check out updates on our Resources section!](#)

The MakerMade M2 CNC kit is used to assemble a large format CNC machine. It is designed to use a router (or another tool) to cut 4' by 8' sheet materials. When used correctly, this machine is very safe. However, some safety precautions must be taken to prevent injury. These include but are not limited to:

- 1. Always follow the safety guidelines and instructions included with the router or other tool you attach to the kit.**
- 2. Always wear ear and eye protection when running your machine.**
- 3. Use adequate dust collection or wear a respirator. Breathing material dust can be harmful.**
- 4. Use proper lifting techniques when loading/unloading materials.**
- 5. Always use caution when connecting/removing the sled. This assembly weighs around 20 lbs.**
- 6. NEVER leave your machine running unattended!**

We're excited to have you in our community of makers and can't wait to see what you create.

Find us on [Facebook](#), [Instagram](#) and [YouTube](#) @makermadecnc and tag your projects!

#MakerMadeMaker

