



MATERIAL: textile, foam rubber, sintepon, wood

Colors palette: more than 100 colors in 5 categories are available.

Please kindly note that handcrafted items may slightly differ in shades and textures.

Only for indoor use.

The armchair has a soft seat and armrests.  
Upholstery is not removable.  
Seat softness and elasticity: Medium firm.

Recommended load < 120 kg

Mostly made to order. Lead time 8-10 weeks.

DIMENSIONS: 1030 x 820 x 790 mm  
APPROXIMATE WEIGHT: 33,3 kg

PACKAGE: Cardboard box 1060 x 860 x 850 mm, 39,6 kg

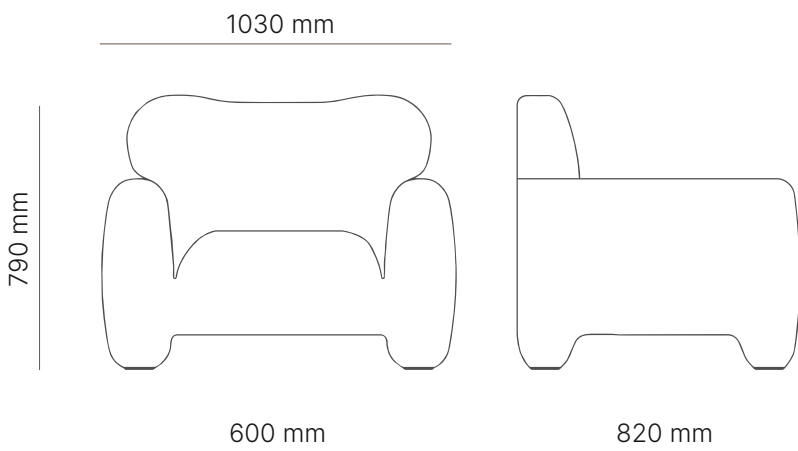

# PAMPUKH armchair

## COLOR

FAÏNA

### CATEGORY A / ASCENDENT

A natural, timeless fabric that adds a living touch to any private or commercial interior. 45% cotton, 19% viscose, 15% wool, 13% polyacrylic, 8% polyamide. Martindale: 60000



020



021



022



031



050



051



060



070



071



072



090



091



093

### CATEGORY A / REYKJAVIK

Live and wild. Created with care to an environment. Suitable for wabi-sabi interiors and people who appreciate authentic beauty. 55% cotton, 27% viscose, 15% polyester, 3% linen. Martindale: 30000



070



091



092

# PAMPUKH armchair

## COLOR

FAÏNA

### CATEGORY B / RENARD

A modern version of cotton velvet with a durable coating. A refined matte surface accents the beauty of shapes. Suitable for premium class interiors with a chic vibe or for other styles where furniture is a center of regard.

80% cotton, 10% modal, 10% polyester. Martindale: 50000



01

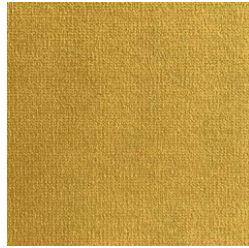

15

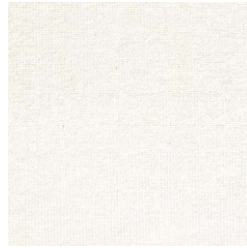

19



22



23



26



32

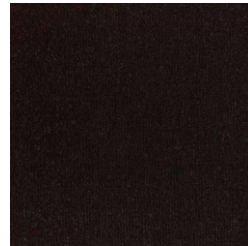

36



41



54



64

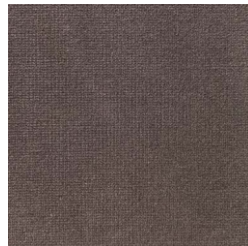

65



71

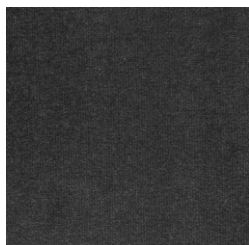

76

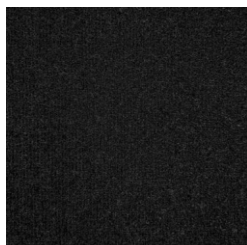

80



88

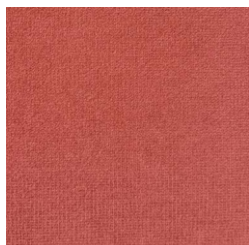

90



98

# PAMPUKH armchair

## COLOR

FAÏNA

### CATEGORY B / BOUGANVILLE

Live, tactile, soft to the touch fabric. Presented in a silent colour palette, each with a rich texture, it provides an owner with a sense of quality living. 63% cotton, 10% polyester, 7% linen, 20% viscose. Martindale: 35000



1



3



4



5



7

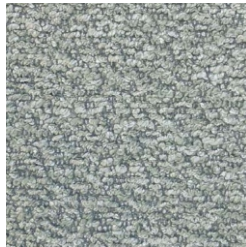

8



20



21

### CATEGORY B / FEIJOCA

A live and tactile fabric. One of the softest in FAÏNA's line, it features a fluffy texture and engages to touch. Recommended for use in private interiors. 56% cotton, 27% polyester, 16% wool, 1% silk. Martindale: 35000

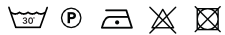

1



2



3



5



20

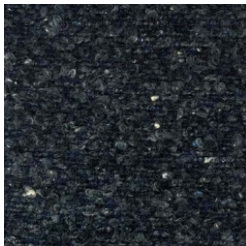

21

# PAMPUKH armchair

## COLOR

FAÏNA

### CATEGORY B / PETUNIA

Live and thoughtful fabric. For people who desire uncompromised quality — visually and sensually. Recommended for private and commercial interiors. 99% cotton, 1% polyamide. Martindale: 35000



2



3



4



5

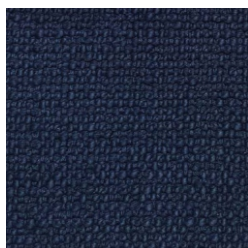

6



9

### CATEGORY B / SAMOS

Live and sensuous. This fabric bestows a cloud-like, soft and natural feel. Recommended for soft seating — at homes or small public areas. 52% cotton, 27% viscose, 21% polyester. Martindale: 80000



01



02



03

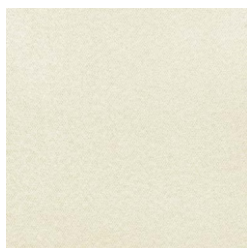

06

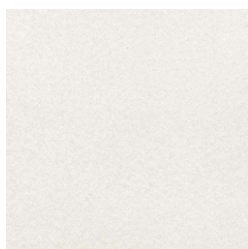

07



16

# PAMPUKH armchair

## COLOR

FAÏNA

### CATEGORY C / LUCREZIA

Live and soulful. This fabric has powerful energy and a special natural feel that brings a living spirit to every interior. Cool properties make it most suitable for warm regions. 44% viscose, 28% cotton, 15% linen, 13% polyester. Martindale: 37000



02



03



05



09



12

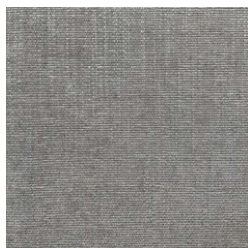

14



19



26



28



31



34



35



42

CATEGORY D / WOOL

Live and sincere — this fabric is a bestseller in FAÏNA palette. Wool beautifully ages. Naturally flame retardant. Dirt-resistant and durable, famous for its versatile use. High thermal conductivity makes it ideal to preserve the warmth of a home. 70% wool, 20% polyester, 5% nylon, 5% other fibres. Light resistance 4-5. Martindale: 100000.



\* Note that stains may remain if liquid gets on the surfaces upholstered with Wool fabric.

# PAMPUKH armchair

## COLOR

FAÏNA

### CATEGORY H / ANGEL

Smart fabric. A reliable choice for contract spaces, residential spaces with pets, medical fields. Easy to maintain and hardwearing. Flame retardant, does not need protective finishes. Can be washed and disinfected.

100% polyester. Martindale: 100000. Colorfastness to light 5/6, ISO 105 B02. Pilling 5, ISO 12945-2. Fire resistance 11M - UNI 9175; EN 1021 part 1/2. BS 5852 crib 5; California TB 117:2013; IMO MED - Ftp 307 part 8.

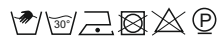

800

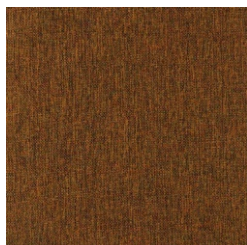

501



300



700



302

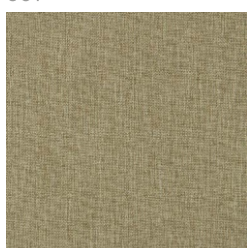

402



401

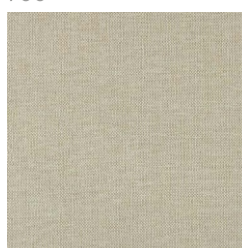

400

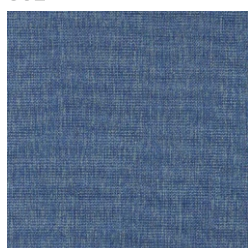

701

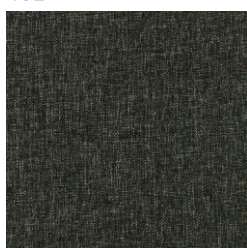

201



# PAMPUKH armchair

## COLOR

FAÏNA

### CATEGORY H / FORRES

Smart fabric. A reliable choice for contract spaces, residential spaces with pets, medical fields. Easy to maintain and hardwearing. Flame retardant, does not need protective finishes. Can be washed and disinfected.

100% polyester. Martindale: 60000. Colorfastness to light: 5/6, ISO 105 B02. Pilling 4/5, ISO 12945-2. Fire resistance BS 5852: Part 1: 1979, source 0 (cigarette)

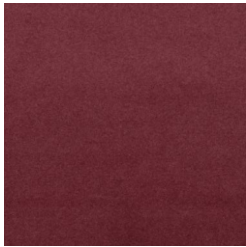
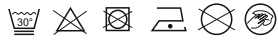

05



06

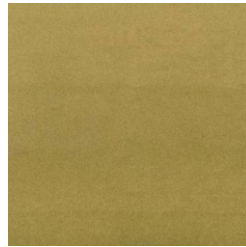

07



08

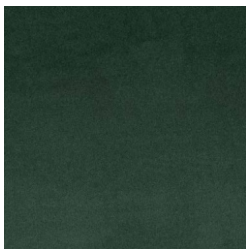

10

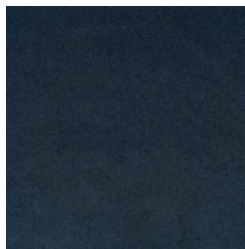

15



17



20

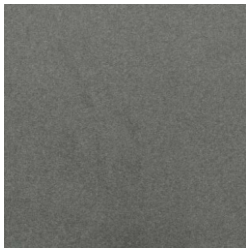

21



22



24



26

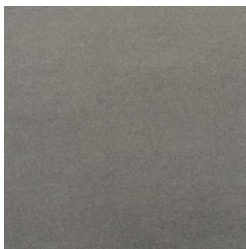

27

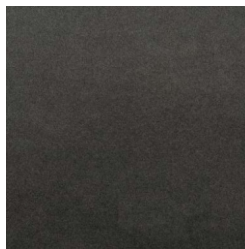

28

## PRODUCT RECEIVING RULES:

Carefully inspect the product at the courier who delivered it. Pay attention to the configuration, the quality of the appearance of the product, the effect of transformation mechanisms (if any). Remember that accepting a product without specifying any flaws that may be detected when purchasing the product (visible flaws) will deprive you of the right to refer to them in the future. Only after inspection sign the act of acceptance of goods.

## ALLOWED AND ARE NOT THE DISADVANTAGES:

- slight difference in the shade of the product;
- a slight (within 10%) difference between the form and the photo of products. All F A I N A items are created by craftsmen manually;
- slight (within 10%) color difference from the photo;
- folds on the upholstery fabric that arise as a result of unloading and disappear after lightly smoothing them by hand;
- folds on the upholstery fabric, as the artistic decision of the designer; stretch fabrics on the surface of the product resulting from its use;
- a slight variation of the upholstery fabric and the asymmetry of the pattern and decor.

## BEFORE USE, READ THE FOLLOWING INFORMATION CAREFULLY:

Aggressive shipping conditions may cause some fabric deformations and folds of furniture upholstered in natural fabric (category A,B,C,D). We recommend to keep the furniture unpacked in a warm and dry room for at least 24 hours without mechanical stress before use. It is also possible to use a steam iron after that.

- a new product may have a particular smell of materials used in the manufacture of furniture, which disappears after a while;
- folds may appear during transportation on furniture. In order for the furniture to get the correct shape, it is enough to keep it at room temperature. The shape of the cushions will recover if you knock them down with your hands;
- furniture upholstery during prolonged use tends to stretch, acquire a more intense shine. Small local areas from permanent sitting may appear on furniture, folds may appear, the softness of fillers may appear, which is not a defect in furniture during manufacture;
- a slight difference in shades is possible in the finishing wooden elements through such a feature of wood as anisotropy (heterogeneity of properties in the direction along or across the fibers);
- finishing materials (fabric, leather, artificial leather) may differ in shades on different parts of the product due to the characteristics of the production process, color reproduction under different light sources, specific properties of the pile, and alike.

## RULES FOR OPERATING UPHOLSTERED FURNITURE

Do not store furniture in damp, unventilated rooms. The optimal operating conditions for upholstered furniture are warm, dry, ventilated rooms at a temperature of 10-28 ° and relative humidity of 45-70%.



It is not allowed to place furniture in places close to the heating system. Do not place hot objects or sharp-edged objects on surfaces lined with fabrics, leather.

It is recommended to protect front surfaces from mechanical damage, from solvents, alkalis, and acids, as well as coffee, juices, berries, fruits, vegetables, fats.

Remove dust with a vacuum cleaner.

When loosening the connections, periodically tighten the bolts, screws, and nuts.

Follow the furniture care rules specified in the warranty, in the passport, and in the operating instructions.

It is not allowed to use seats, a berth for jumping, and other physical exercises.

On a standard product, an acceptable landing without the additional support of one person weighing no more than 120 kg.

It is not recommended to step on the products, stand on the products at full height, sit on the back and on the armrests, swing on the furniture. To prevent accidents and damage to your furniture, do not allow children to jump on sofas, armchairs, beds, and chairs.

To avoid damage to the floor surface of the product, move it slightly by lifting it above the floor.

**IMPORTANT! UPHOLSTERED FURNITURE IS INTENDED FOR REST, SITTING, AND LYING. IT IS NOT RECOMMENDED TO BECOME THE FEET ON THE PRODUCT OR SEAT ON THE BACK OF THE PRODUCT.**

**DO NOT ALLOW PARTICLES OF SAND BETWEEN THE LEGS OF THE FURNITURE AND THE FLOOR.**

**PLEASE NOTE THAT WHEN PACKING UPHOLSTERED FURNITURE, IN ORDER TO AVOID DAMAGE TO THE UPHOLSTERY FABRIC, ACCESSORIES SHOULD BE WRAPPED IN POLYETHYLENE AND CARDBOARD. ALSO, LARGE ITEMS SHOULD BE PLACED IN THE CRATES.**

**UNPACK THE FURNITURE CAREFULLY! TO REMOVE CARDBOARD AND POLYETHYLENE TAKE AWAY CAREFULLY THE ADHESIVE TAPE FROM IT.**

## FURNITURE CARE RULES

**ATTENTION: COVER IS NOT REMOVABLE AND CAN NOT BE WASHED!**

- To maintain the furniture in good condition, it is recommended to regularly clean the surface of the fabric with a soft hairbrush or remove dust with a vacuum cleaner using a special nozzle and gentle operation.
- Removing local contaminants (stains) must be done immediately, not allowing them to dry.
- If you chose a longitudinal-transverse weave upholstery (tapestry, chenille), which includes natural fibers, remember that contact of the fabric with exposed parts of the body can lead to greasy fibers.
- During the operation of furniture upholstered in pile fabrics, areas with more frequent sitting can form areas with a flat pile and a changed color of the fabric. This problem is freely eliminated by treating this area with a steam iron, drying of the restored area with soft heat.
- Avoid direct sunlight on the furniture upholstery, thereby preventing premature fading of the fabric color.

**ATTENTION! WHEN CHOOSING A DETERGENT, IT IS NECESSARY TO FAMILIARIZE YOURSELF WITH THE INSTRUCTIONS FOR ITS USE OR CONSULT WITH SPECIALISTS OF SPECIALIZED ENTERPRISES.**

Please remind that each fabric has different care recommendations. You can find a full information and care signs for certain fabric on the fabric color pages.

## TRANSPORTATION AND STORAGE:

The product should be transported and stored in the package in compliance with safety precautions to avoid mechanical damage and exposure to atmospheric precipitation.

## WARRANTY

The warranty period for the operation of wood and ceramic products is 12 months and is calculated from the date of sale specified in the warranty card, and in the absence thereof from the date of shipment from the warehouse.

Free maintenance (furniture repair) occurs during the warranty period, subject to the conditions of transportation, operation and recommendations for the care of the furniture.

Free warranty repair applies to furniture defects arising from the fault of the manufacturer.

Insufficiencies in the work performed that can be detected upon receipt of the product (claims regarding the appearance of the product, lack of completeness, as well as inconsistencies in the order, etc.) are accepted only upon receipt of the product and provided that the unpacking was carried out by courier. In the future, such claims are not accepted, all work is carried out only at the expense of the buyer.

## PROCEDURE FOR CLAIMS SUBMISSION.

Claims on the appearance of the product, the incompleteness of the set are accepted only directly upon receipt of the product. Further in future, such claims are not accepted, all work is carried out only at the expense of the buyer.