

Axiom® IoT-Enabled ECOPOWER® Faucet

FEATURES

- Wireless Communication
- Connects seamlessly with Georgia-Pacific's (GP) KOLO™ Smart Monitoring System and through an API to facilities monitoring platforms
- Service agreement with GP required to enable IoT or Smart Features
- ECOPOWER faucet's operation is independent of its IoT capability
- Some of the IoT-enabled Smart Features include: failure detection, usage, water consumption, and battery/capacitor charge
- Self-generating hydropowered ECOPOWER system
- No minimum daily usage requirement
- Micro-sensor positioned underneath the spout head for accurate hand detection ensuring smooth and consistent water distribution
- Durable chrome plated spout body
- Single-hole mount
- Kit includes spout body, controller box , and mounting hardware - less supply lines
- Aerated flow
- Equipped with 0.5 gpm flow control



MODELS

- TEL145i2-D60E#CP**
 - TELS145 (Axiom Spout)
 - TELC105i2-D60E (Controller: 0.5gpm, 60 sec on-demand)
- TEL145i2-D60EM#CP
 - **TEL145i2-D60E#CP** (Axiom Spout Kit)
 - TLM10 (Mixing Valve)
- TEL145i2-D60ET#CP
 - **TEL145i2-D60E#CP** (Axiom Spout Kit)
 - TLT10R (Thermostatic Mixing Valve)
- TEL145i2-D10E#CP**
 - TELS145 (Axiom Spout)
 - TELC105i2-D10E (Controller: 0.09gpc, 10 sec on-demand)
- TEL145i2-D10EM#CP
 - **TEL145i2-D10E#CP** (Axiom Spout Kit)
 - TLT10R (Mixing Valve)
- TEL145i2-D10ET#CP
 - **TEL145i2-D10E#CP** (Axiom Spout Kit)
 - TLT10 (Thermostatic Mixing Valve)
- TEL145i2-C20E#CP**
 - TELS145 (Axiom Spout)
 - TELC105i2-C20E (Controller: 0.19gpc, 20 sec continuous)
- TEL145i2-C20EM#CP
 - **TEL145i2-C20E#CP** (Axiom Spout Kit)
 - TLM10 (Mixing Valve)
- TEL145i2-C20ET#CP
 - **TEL145i2-C20E#CP** (Axiom Spout Kit)
 - TLT10R (Thermostatic Mixing Valve)

PRODUCT SPECIFICATION

TOTO Model #_____ The faucet shall have hydropowered self-generating, ECOPOWER System. The faucet shall have maximum of 60 seconds on-demand flow (0.5 gpm), or 10 seconds on-demand flow (0.09 gpc), or 20 seconds continuous flow (0.19 gpc). Product shall have anti-scald shape memory alloy thermostatic mixing valve (-ET models only). The faucet shall have self-adjusting sensor.

CODES/STANDARDS

- Operates below federally mandated consumption limit of 0.25gpc
 - Complies to California Green Building Code, CALGreen of 0.20 gpc
 - Meets or exceeds ASME A112.18.1/CSA B125.1, and NSF 372
 - FCC compliant to Part 15
 - Certifications: IAPMO(cUPC), State of Massachusetts, and others
 - California Green Code and City of Los Angeles Water Efficiency Ordinance
 - ADA compliant
 - Complies with federal and state statutes as low-lead (contains a weighted average of 0.25% lead or less)
 - Complies with CA Prop 65 warning requirements
- * For codes and standards of mixing valves TLM10 and TLT10R, please refer to corresponding product spec sheets.



TEL145i2 Series

Axiom® IoT-Enabled ECOPOWER® Faucet

SPECIFICATIONS

Power Supply	ECOPOWER	
Sensor Detection Range	5-1/8" - 7-7/8" (130 - 200mm) Sensor is self-adjusting	
Water Supply Pressure	Min (Dynamic/Flowing) Pressure: 15 psi (100kPa) Max (Static) Pressure: 80 psi (551kPa)	
Water Supply	G1/2 (1/2 NPSM compatible)	
Inlet Temperature Range	39-110°F(4-42°C)	
Ambient Temperature	32-104°F(0-40°C)	
Humidity	Max. 90% RH	
Flow Rate	D10E	0.09 gpc* - max 10 second On-Demand** (0.09 gpc = 0.5 gpm x 10/60 sec) Equipped with 0.5 gpm flow control
	C20E	0.19 gpc* - 20 second Continuous*** (0.19 gpc = 0.5 gpm x 20/60 sec) Equipped with 0.5 gpm flow control
	D60E	0.5 gpm
Warranty	Three years	

*Gallons per cycle (gpc) is the amount of water per usage cycle.

** On-demand refers to the way in which the water is dispersed (i.e.; water is only dispersed when the sensor is activated by the user as needed).

*** Continuous means that water is dispersed for a continuous 20 second cycle.

NOTE

Following the federal mandate for water efficiency outlined in the Environmental Protection Act of 1992, faucets can be rated for water consumption based on two categories: Flow Rate and Water Consumption. TOTO uses the water consumption standard because it is the most accurate method of measuring water use. TOTO faucets also comply with the CALGreen Guideline of water usage.

Water Saving

On-Demand [10 sec.] faucet (0.09gpc)
Federal Standard (0.25gpc) – 64% less
CAL Green (0.20gpc) – 55% less

Continuous [20 sec.] faucet (0.19gpc)
Federal Standard (0.25gpc) – 24% less
CAL Green (0.20gpc) – 5% less

Axiom

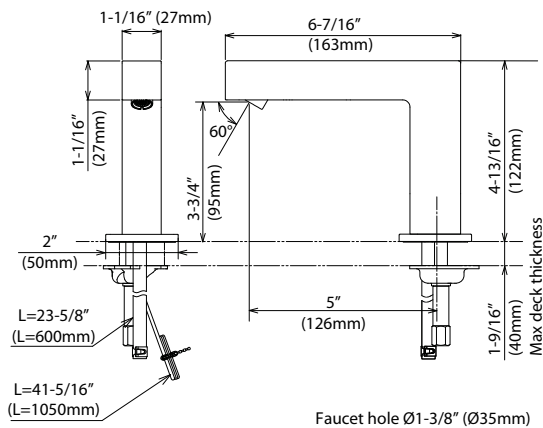

Controller

The IoT daughter card installation requires minimum 13/16" (20mm) clearance on the left side of the controller. Please refer to the diagram, as shown.

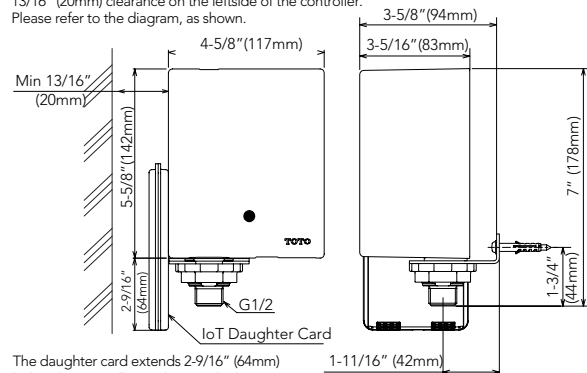

The daughter card extends 2-9/16" (64mm) below the controller. Make sure the bottom of the daughter card doesn't hit any obstacles.

Available Mixing Valves

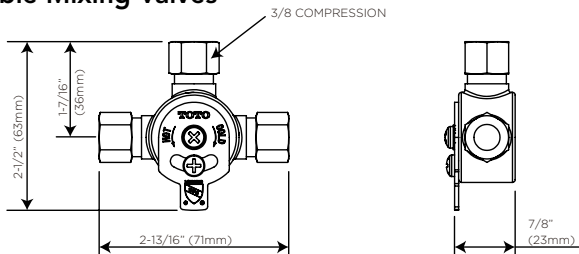

Hot/Cold Mixing Tee (TLM10)

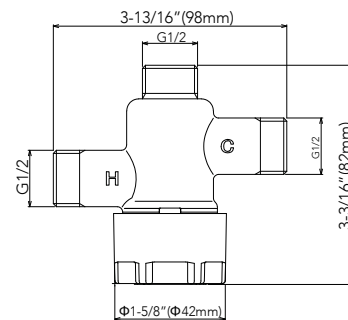

G1/2 compatible with 1/2 NPSM

Thermostatic Mixing Valve (TLT10R)