

For MrSteam Models W216C, W219C, W228C, W236C, W248C, W500, W542, W634

IMPORTANT NOTE: As you follow these instructions, you will notice warning and caution symbols. This blocked information is important for the safe and efficient installation and operation of this Towel Warmer. These are types of potential hazards that may occur during this installation and operation:

! WARNING states a hazard may cause serious injury or death if precautions are not followed.

! CAUTION signals a situation where minor injury or product damage may occur if you do not follow instructions.

IMPORTANT NOTE: This highlights information that is especially relevant to a problem-free installation.

! WARNINGS

- BE CERTAIN ELECTRICITY IS SHUT OFF AT MAIN PANEL BEFORE ATTEMPTING TO WIRE OR SERVICE THE TOWEL WARMER. Follow instructions to make certain the Towel Warmer is properly mounted and secured to the wall. FAILURE TO FOLLOW THESE STEPS COULD RESULT IN HAZARDOUS CONDITIONS INCLUDING ELECTROCUTION.
- Do Not alter or modify any Mr.Steam products. Doing so may result in an inoperable or hazardous installation and will void the warranty.
- Install Towel Warmers in upright position only. Locate wiring box with indicator light on bottom as shown. Failure to install properly may result in overheating and a hazardous condition.

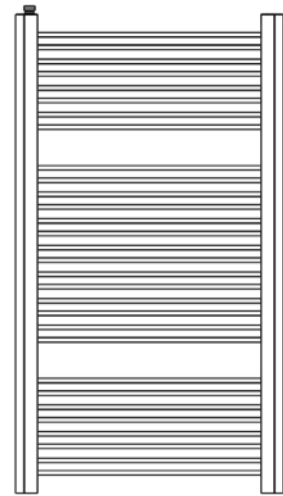

Towel Warmer with Heating Element up

1. Towel Warmer Element Replacement only to be performed after consultation with a MrSteam Technical Service Representative.
2. REPAIR PROCEDURES MUST BE ACCOMPLISHED BY A QUALIFIED LICENSED ELECTRICIAN.
3. Use only MrSteam supplied replacement parts.
4. Follow all instructions in the Towel Warmer Installation, Operation, and Maintenance Manual.

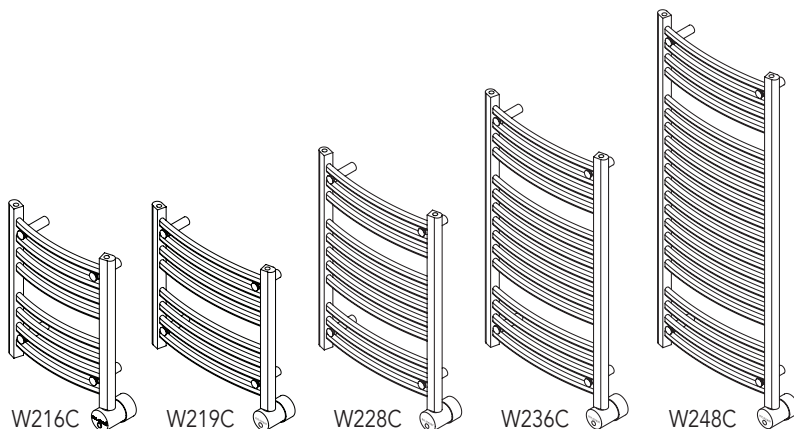

Fig. 1: Wiring Box Assembly

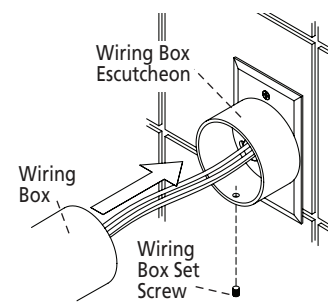
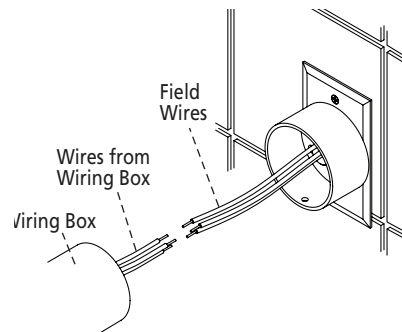

Fig. 2: Disconnection of Wiring Box



Models W2XXC

1. the power source to the towel warmer. Verify power is off.
2. Disconnect the wiring box from the escutcheon by loosening the wiring box set screw. (see Fig. 1)
3. Disconnect the main power wires that are connected internally in the wiring box. (see Fig. 2)

- Remove the wiring box from the towel warmer by loosening the Allen screws on the upper collar. (see Fig. 3)
- Determine the type of mounting hardware:
 - Plastic Hardware: Remove the plastic mounting brackets by removing the covers from the clamps, then loosen the four clamp screws. (see Fig. 4.1).
 - Brass Hardware: Remove the brass mounting brackets by removing the clamp set screw from bracket, then remove the 4 clamp screws. (see Fig. 4.2).
- Once the mounting brackets and the wiring box have been disconnected the towel warmer should be free from the wall.

Models W542/W634

- Disconnect the power source to the towel warmer. Verify power is off.
- Disconnect the wiring box from the escutcheon by loosening the wiring box set screws. (see Fig. 1)
- Disconnect the main power wires that are connected internally in the wiring box. (see Fig. 2)
- Remove the wiring box from the towel warmer by first loosening the Allen screws on the upper collar. (see Fig. 3)
- Disconnect the towel warmer from the brass inserts by removing the set screws. (see Fig. 5)
- Remove the sliding escutcheons

Models W500

- Disconnect the power source to the towel warmer. Verify power is off.
- Disconnect the wiring box from the lower threaded flange by loosening the wiring box set screw. (see Fig. 1)
- Disconnect the main power wires that are connected internally in the wiring box. (see Fig. 2)
- Remove the wiring box by loosening the Allen screws on the upper collar. (see Fig. 3)
- Disconnect the upper support bracket from the upper threaded flange by removing the screws. (see Fig. 6)

Fig. 3: Removal of Wiring Box Allen screws

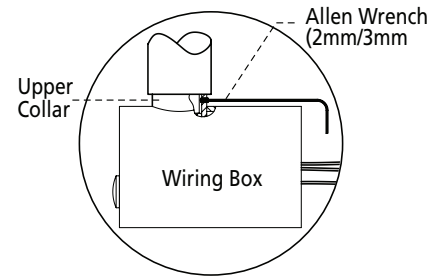

Fig. 4.1: Mounting of Towel Warmers with plastic brackets

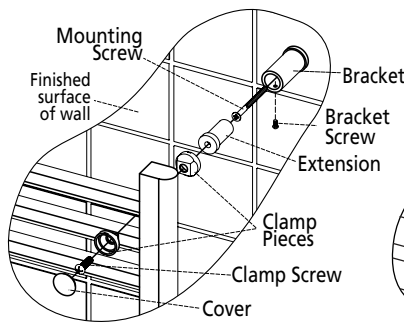

Fig. 4.2: Mounting of Towel Warmers with brass brackets

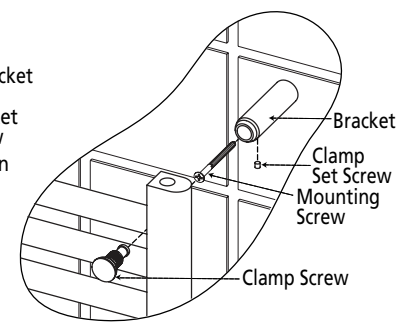

Fig.5: Mounting of W542 and W634 Towel Warmers

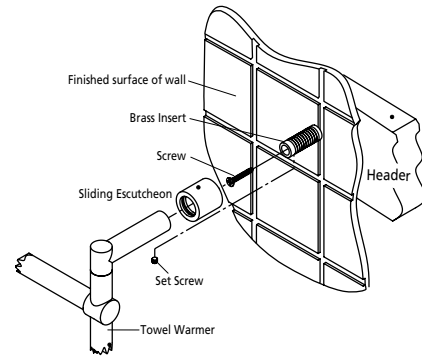
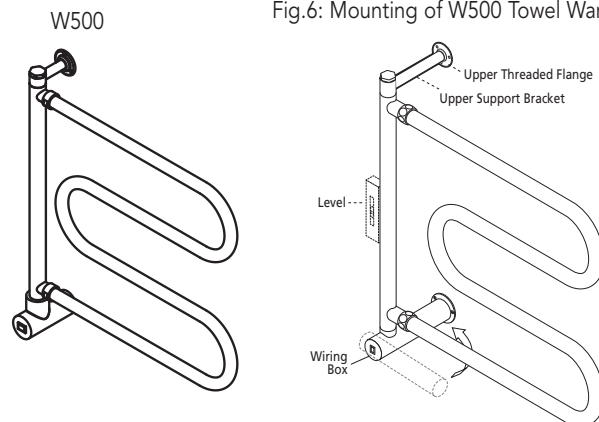

Fig.6: Mounting of W500 Towel Warmer



Element Replacement

1. The towel warmer contains fluid. In order to prevent fluid loss from the towel warmer, position the towel warmer with the heating element facing up. (see Fig. 7)
2. Using an adjustable wrench loosen the heating element and remove it by lifting the element upward
3. Screw the new element in the place of the old one and make sure the seal is tight.
4. Reassemble and remount the towel warmer by following the disassembly steps in the reverse order.
5. Bleed the towel warmer.
 - A. Run the towel warmer for 45 minutes.
 - B. Open the top bleeder valve and allow a small amount of fluid to escape. (see Fig. 8)
 - C. Close the bleeder valve.
 - D. Test to make sure the towel warmer is heating evenly.

NOTE: Broadway Collection 200 Series Towel Warmers do not need to bleed.

Fig.7: Towel Warmers with Heating Element in "UP" position (shown with wiring box removed)

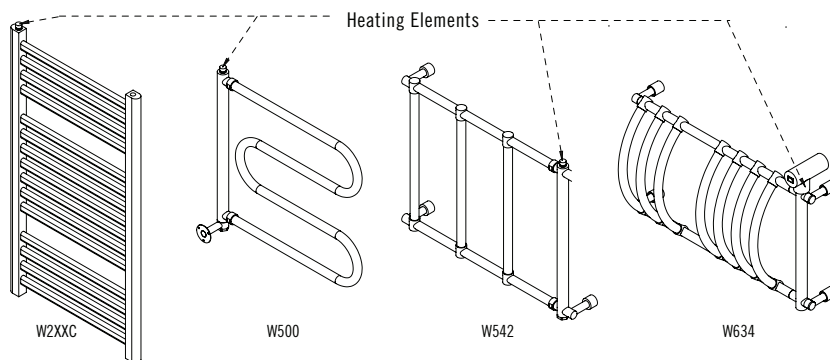

Fig.8: Locations of Towel Warmer Top Bleeder Valves

