

e2™ Ceiling Mount Trapeze

STP-CM-24 / STP-CM-32
(DC140 - RevC)

A

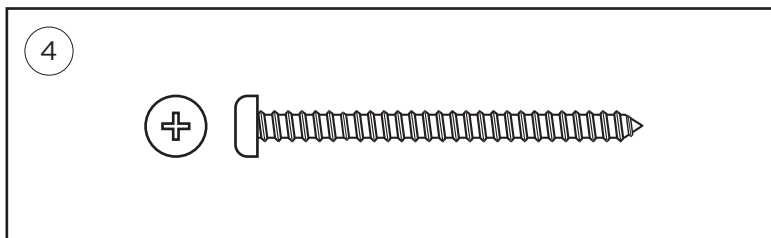
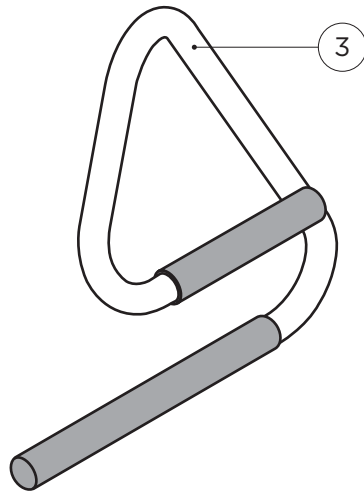
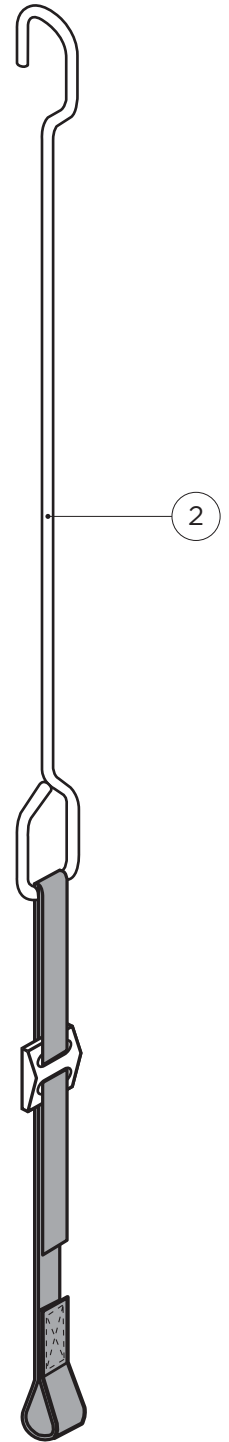
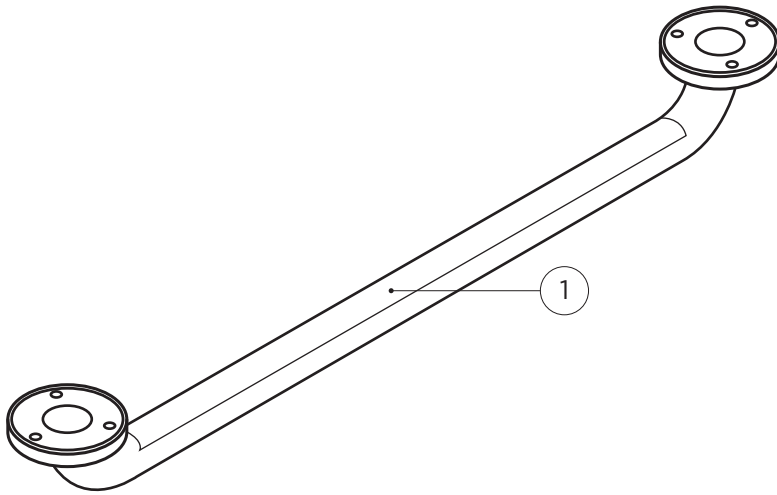

B

1

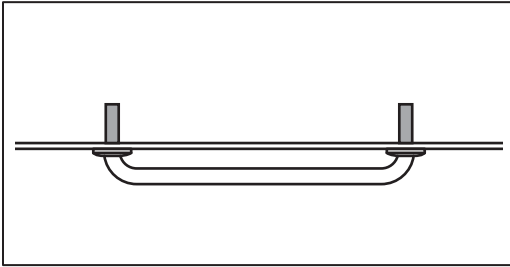

2

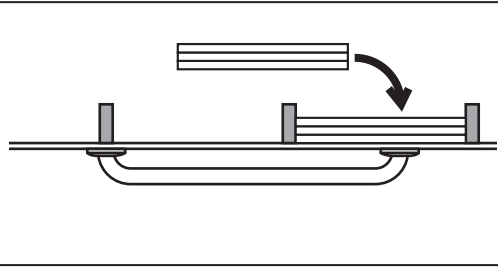

3

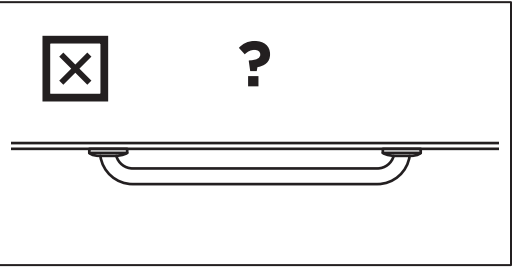

4

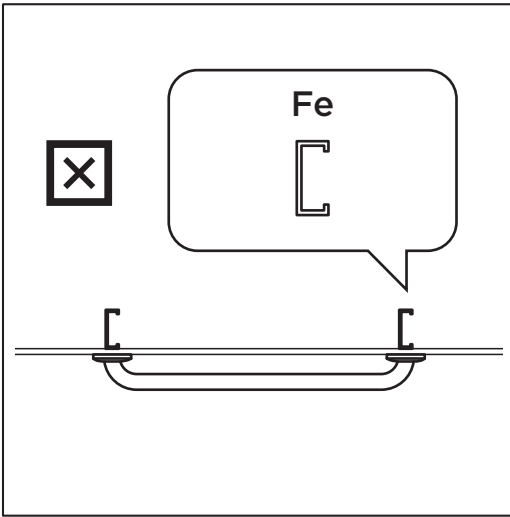

5

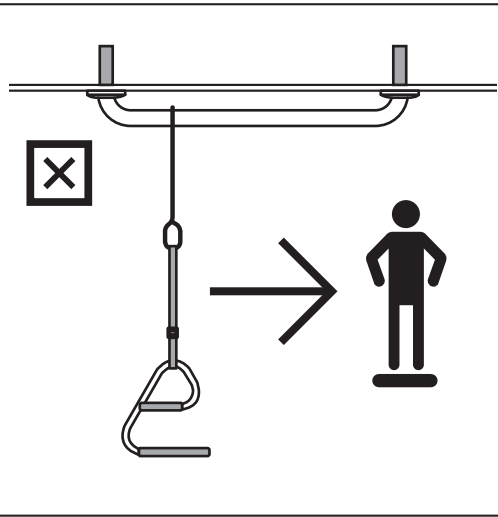

6

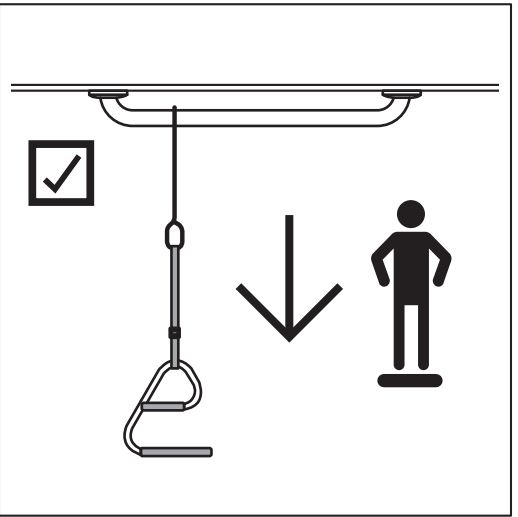

C

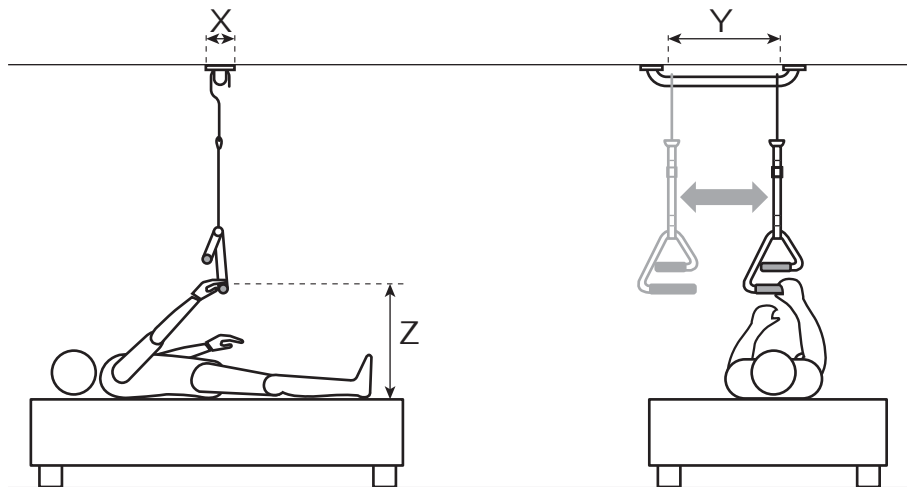

1

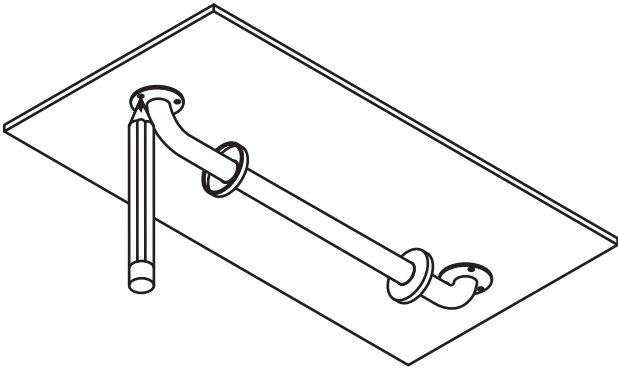

2

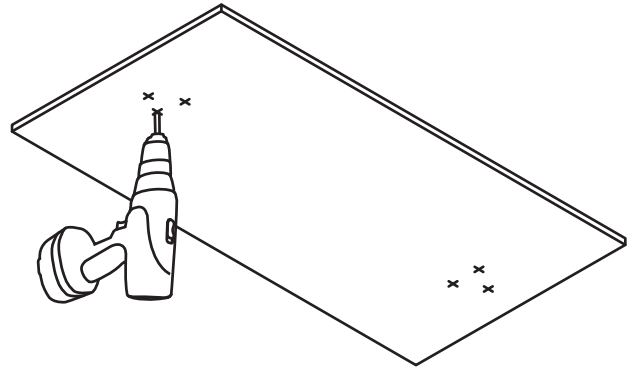

3

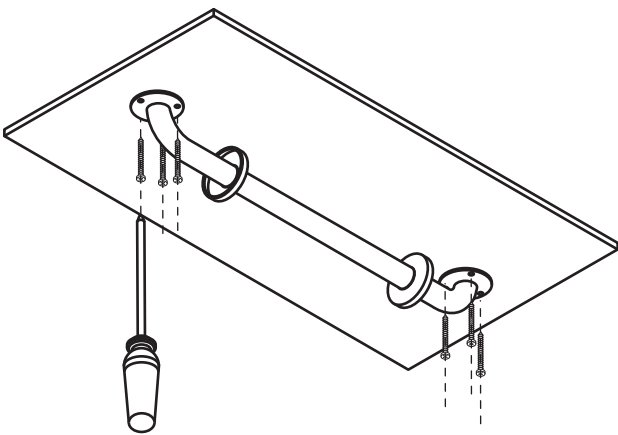

4

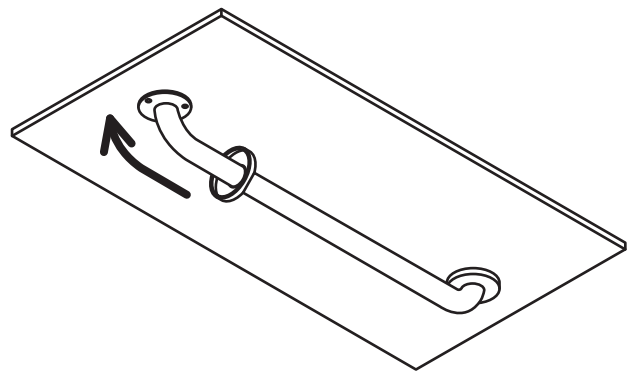

5

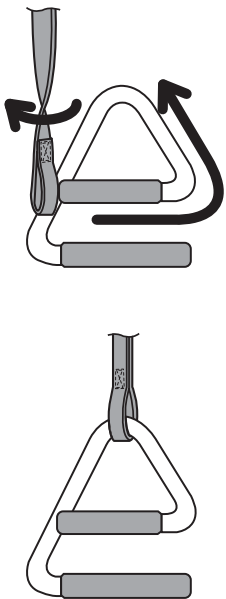

6

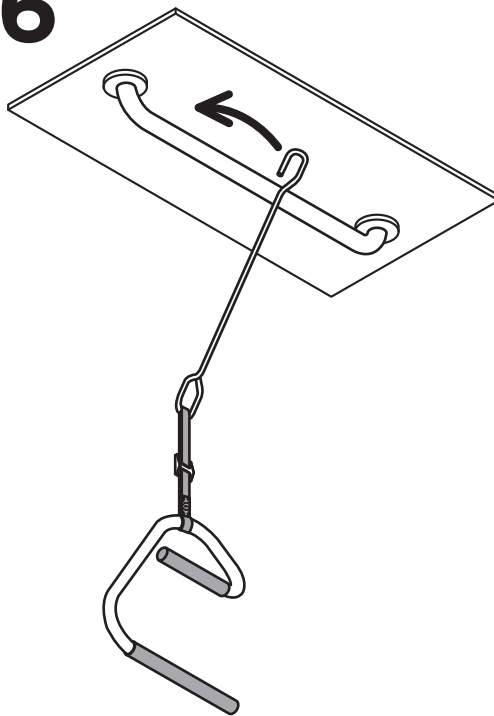

7

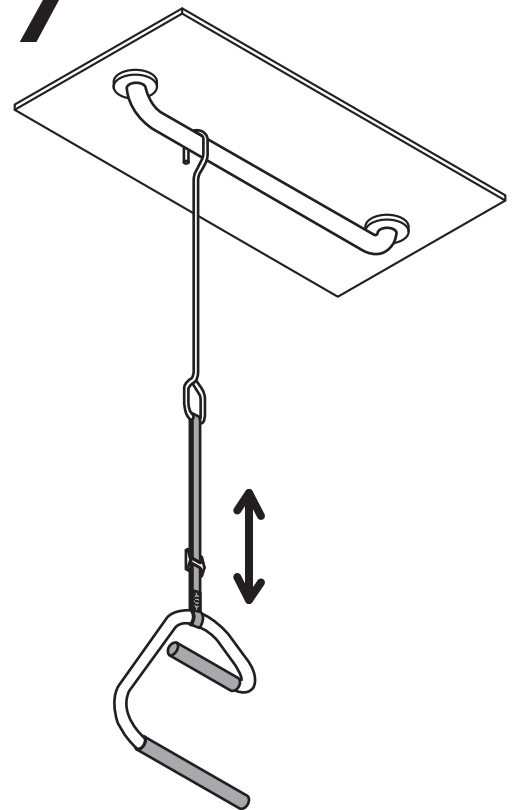

E

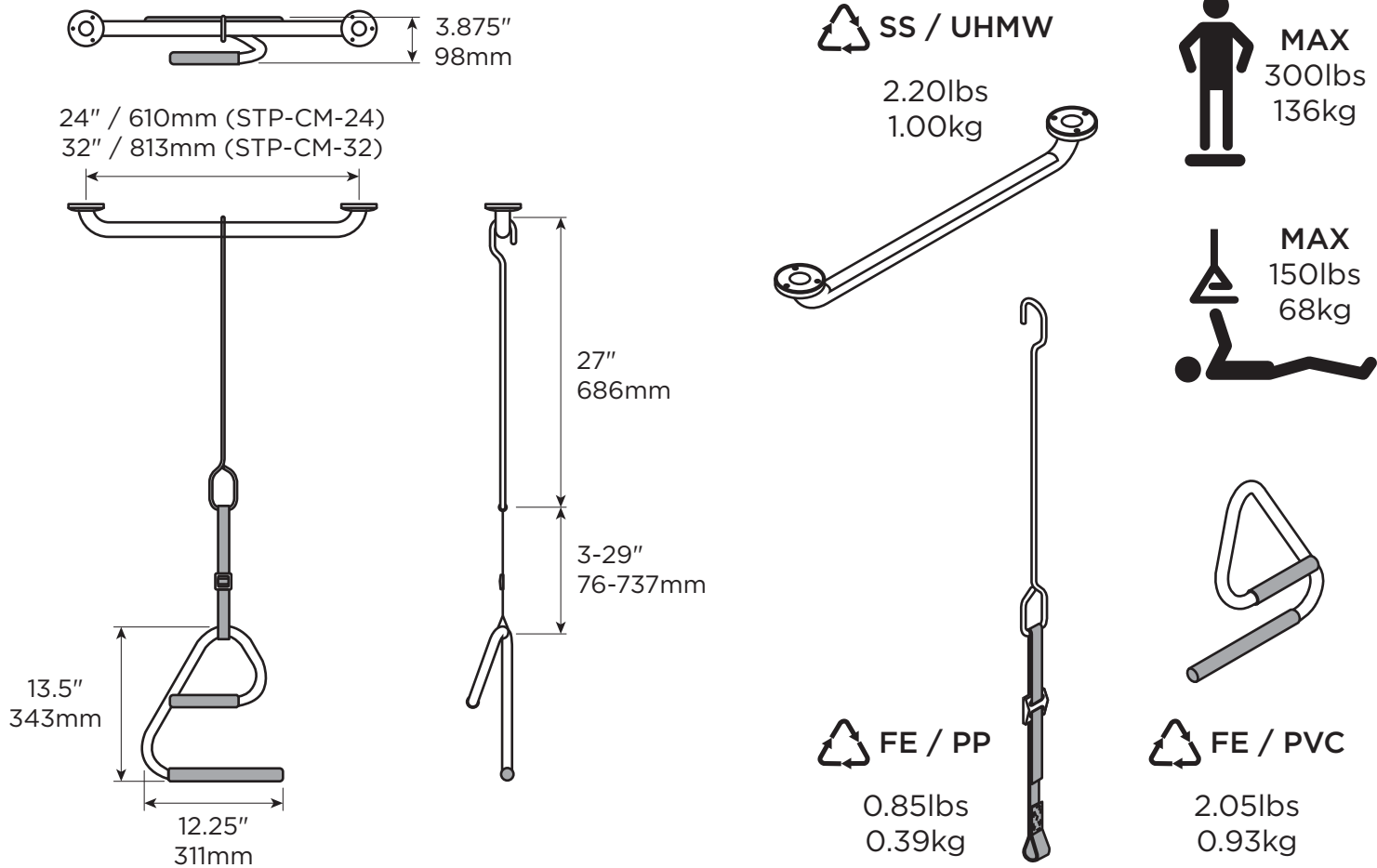

F

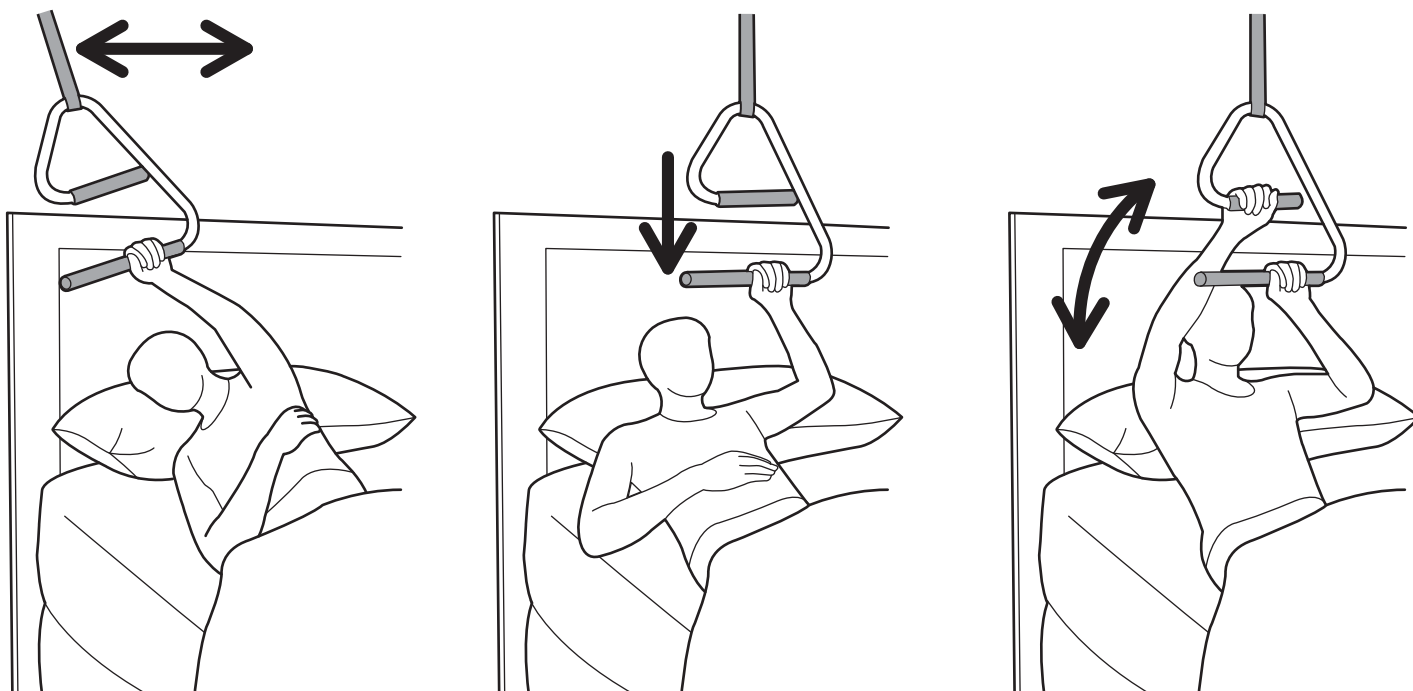

English

OVERVIEW

Thank you for choosing the e2 Ceiling Mount Trapeze from HealthCraft. Please read and understand the instructions in this manual; keep manual for future reference. It is your responsibility to see that your e2 Ceiling Mount Trapeze is properly assembled, installed, and cared for. Failure to follow instructions in this manual could result in serious injury or death. If you are not equipped to undertake the outlined work, we would recommend that you have your e2 Ceiling Mount Trapeze installed by a qualified contractor.

The e2 Ceiling Mount Trapeze is an over-bed trapeze system that secures to the ceiling. The trapeze handle features two offset ladder rungs to allow for improved use of arm strength and increased comfort. Additionally, it can slide sideward / laterally on the ceiling mounted grab bar to store out of the way when not in use. The e2 Ceiling Mount Trapeze is intended for moderate vertical load bearing to provide sitting and standing support for people with reduced mobility. The grab bar is installed to a structural ceiling, and a metal hook is looped onto the grab bar. The trapeze handle is connected with an adjustable strap to the metal hook. The maximum user weight for this product is 300lbs / 136kgs. No more than 150lbs / 68kgs is to be exerted on the e2 trapeze (sitting support only). NOTE: Product is not intended to support full body weight. The e2 Ceiling Mount Trapeze is not to be used in any other way than described above.

LIMITED LIFETIME WARRANTY

Products are covered by a limited lifetime warranty against defects in materials and workmanship for the original purchaser. Warranty excludes products that have been damaged through misuse, accidental damage, alteration, normal wear and tear, wood material and stain, or the use of corrosive or abrasive cleaning products.

Buyer hereby indemnifies, agrees to hold harmless and defend HealthCraft Products Inc. from and against any and all liabilities, claims, (founded and unfounded), losses, damages, costs and expenses (including without limitation consequential damages and reasonable professional fees) resulting from buyers specification, application, or improper use of goods described hereon; buyers omission or neglect. HealthCraft Products Inc. does not assume any liability for damage resulting from services performed by others or faulty installation, misuse or misapplication of goods sold by HealthCraft Products Inc. HealthCraft Products Inc. shall not be liable for prospective profits or special, indirect, or consequential damages, or for the cost of any corrective work done without HealthCraft Products Inc. prior approval. HealthCraft Products Inc. total liability hereunder shall in no event exceed the purchase price of the goods specified hereon. Specifications subject to change without notice.



DELIVERY CONTENTS / e2 TRAPEZE CEILING MOUNT FIGURE A.

1. Grab Bar with Low Friction Strip
2. Metal Hook with Adjustable Strap
3. e2 Trapeze Handle
4. #10 x 2" Wood Screw, S/S (x6)

INSTALLATION WARNINGS

FIGURE B.

1. Grab bar must be installed to ceilings that are structurally sound.
2. If desired installation location does not have adequate structure, add wood blocking.
3. CAUTION - Do not install if structure above ceiling is unknown.
4. CAUTION - Do not install into metal studs.
5. CAUTION - Do not pull along the length of grab bar when using trapeze handle for weight bearing. Metal hook may slide and injury may occur.
6. Only pull perpendicular to the grab bar when using the trapeze handle.

SUGGESTED CEILING MOUNT LOCATIONS

FIGURE C.

To determine the optimal mounting location of the ceiling grab bar, we recommend walking through the motions of a transfer (laying down, sitting up, etc.). Consider the following to accommodate:

X = the rail hanging down directly over the palms of user when laying down
Y = the horizontal movement of metal hook - from overbed to storage positions
Z = the adjustable strap length so user can grab bottom rail of e2 trapeze when laying down.

NOTE: The shorter handle of the e2 trapeze handle should be closer to the head of the bed.

INSTALLATION

FIGURE D.

1. Mark location of grab bar on ceiling.
2. Drill pilot holes for fasteners.
3. Fasten the grab bar to ceiling using appropriate fasteners.
4. Use flange covers to conceal mounting fasteners.
5. Attach e2 handle thru loop on strap.
6. Attach the metal hook onto the grab bar on ceiling.
7. Adjust strap to appropriate height for trapeze handle.

TECHNICAL DATA

See Figure E.

PRODUCT USAGE

See Figure F.