

BOXIO WASH

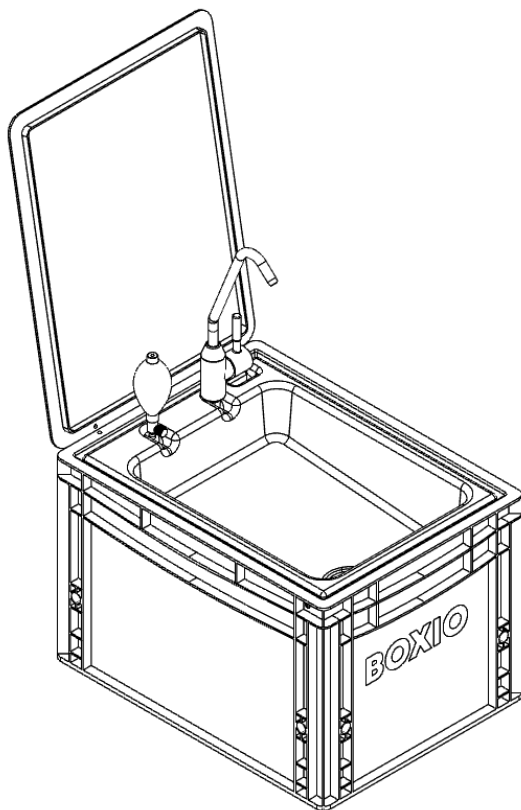

D

Montageanleitung und Benutzerhandbuch



EN

Assembly instructions and user's manual

BG	Инструкции за монтаж и ръководство на потребителя	IRL	Treoracha comhdhála agus leabhrán úsáideora
CZ	Návod k montáži a uživatelská příručka	LT	Montavimo instrukcijos ir naudotojo vadovas
DK	Samlevejledning og brugervejledning	LV	Montāžas instrukcijas un lietotāja rokasgrāmata
ES	Instrucciones de montaje y manual del usuario	M	Istruzzjonijiet għall-muntar u manwali tal-utent
EST	Kokkupanekujuhend ja kasutusjuhend	NL	Montagehandleiding en gebruikershandleiding
FIN	Asennusohjeet ja käyttöohjeet	P	Instruções de montagem e manual do utilizador
FR	Instructions de montage et manuel de l'utilisateur	PL	Instrukcja montażu i podręcznik użytkownika
GR	Οδηγίες συναρμολόγησης και εγχειρίδιο χρήσης	RO	Instrucțiuni de asamblare și manual de utilizare
H	Szerelési utasítások és használati útmutató	S	Monteringsanvisningar och användarmanual
HR	Upute za montažu i korisnički priručnik	SK	Návod na montáž a používateľská príručka
I	Istruzioni per il montaggio e manuale dell'utente	SLO	Navodila za sestavljanje in uporabniški priročnik

D I. LIEFERUMFANG WAS IST IN DEINER BOXIO

EN I. SCOPE OF DELIVERY WHAT'S IN YOUR BOXIO

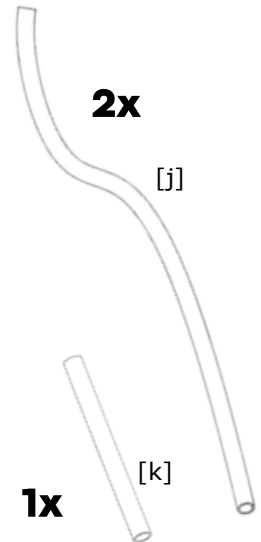
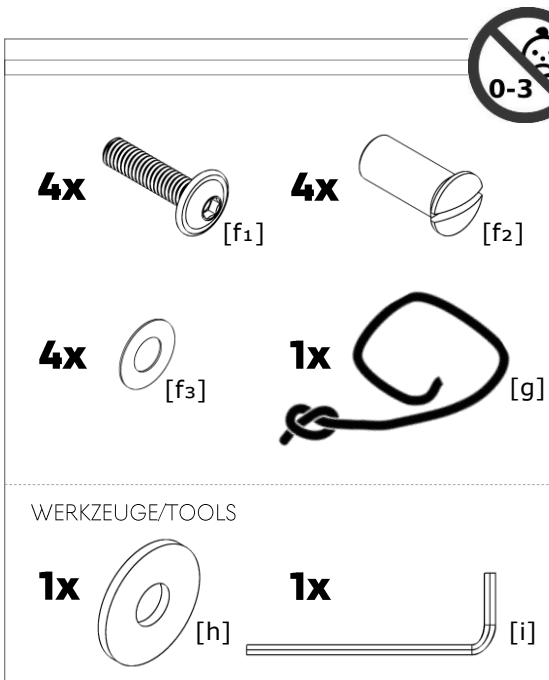
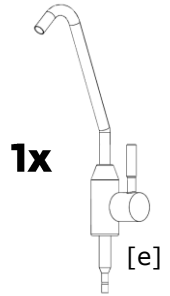
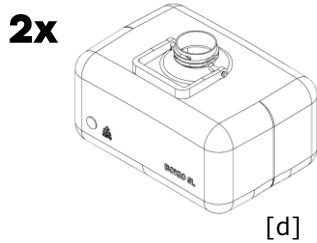
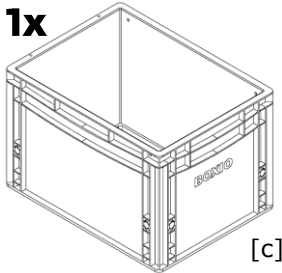
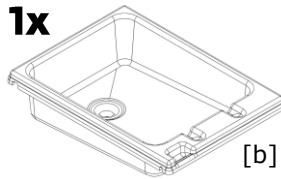
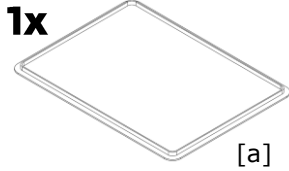

BG обхват на доставката
 CZ Rozsah dodávky
 DK Leveringsomfang
 ES Contenido del embalaje
 EST Tarne ulatus
 FIN Toimituksen laajuus
 FR Contenu de la livraison
 GR Πεδίο εφαρμογής της παράδοσης
 H Szállítási terjedelem
 HR opseg isporuke
 I Ambito di consegna

IRL raon feidhme an tseachadta
 LT Pristatymo apimtis
 LV Piegādes joma
 M ambitu tal-kunsinna
 NL Omvang van de levering
 P Âmbito da entrega
 PL Zakres dostawy
 RO Domeniul de aplicare a livrării
 S Leveransens omfattning
 SK Rozsah dodávky
 SLO Obseg dobave

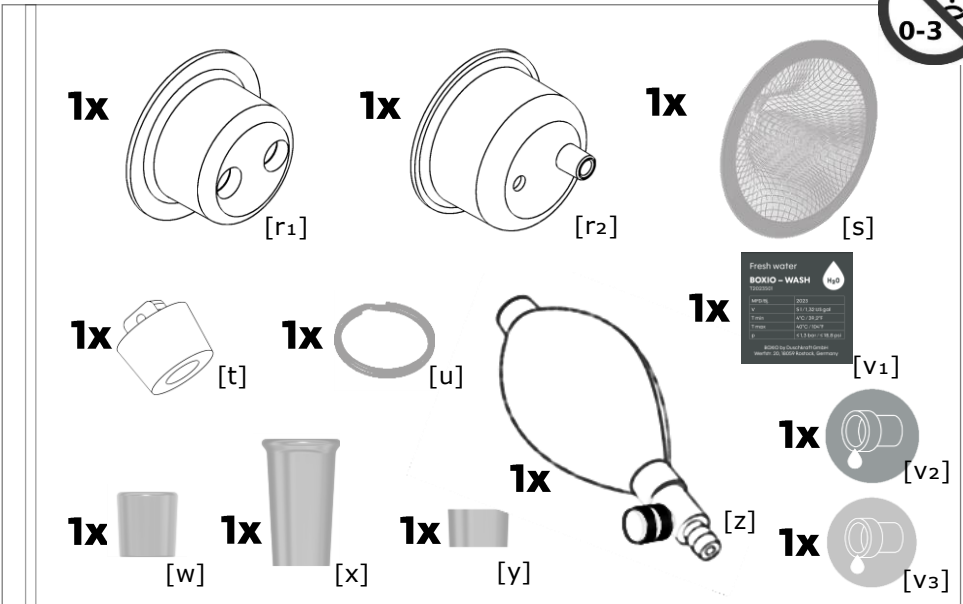
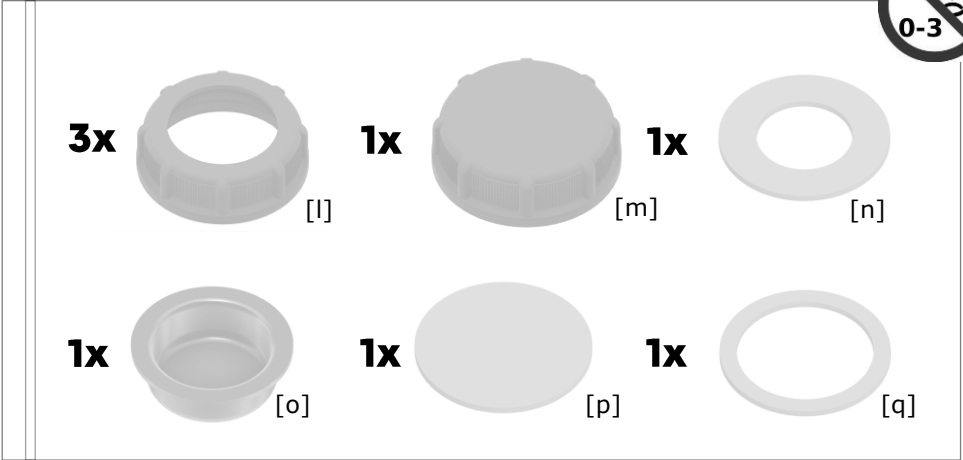

D II. ZUSAMMENBAUANLEITUNG BAU DIR DEINE BOXIO

EN II. ASSEMBLY INSTRUCTIONS BOUILD YOUR BOXIO

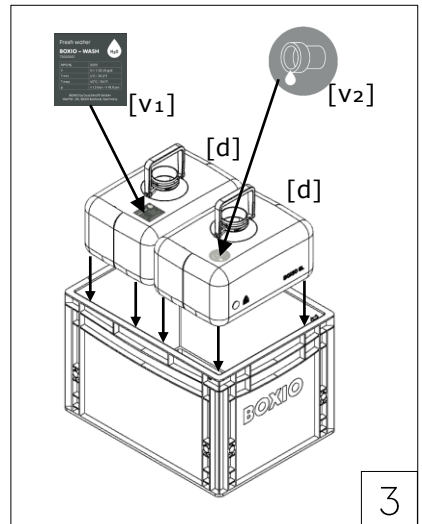
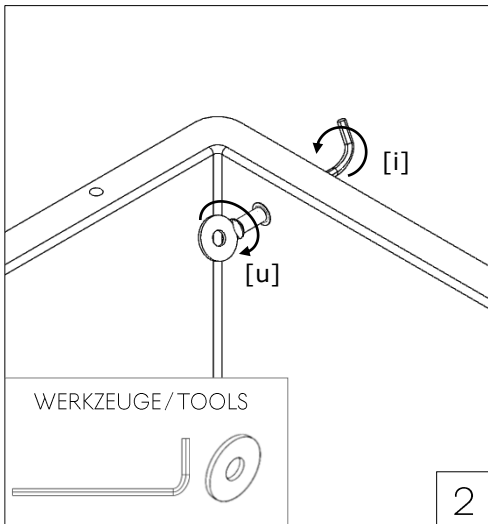
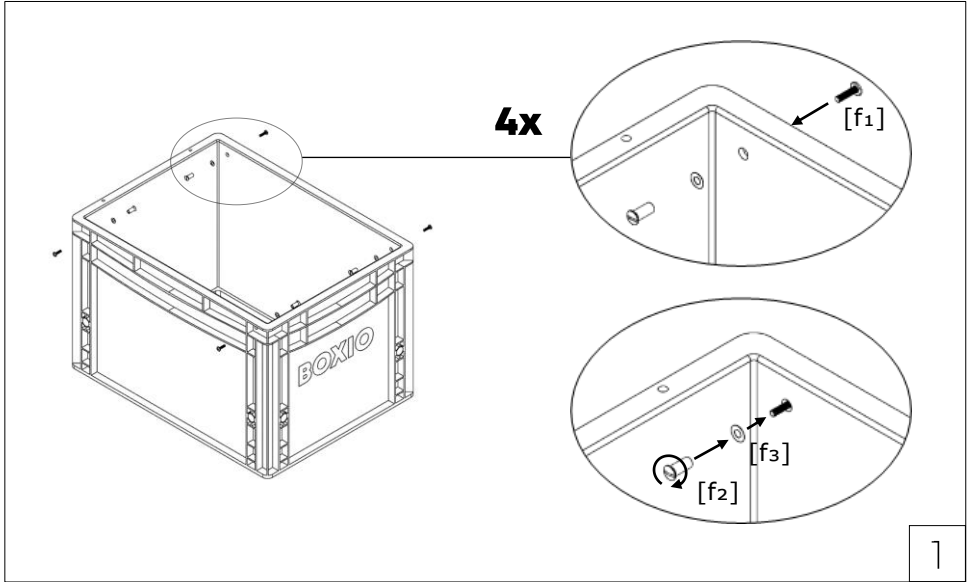

BG Инструкции за монтаж
 CZ Návod k montáži
 DK Samlevejledning
 ES Instrucciones de montaje
 EST Kokkupanekujuhend
 FIN Asennusohjeet
 FR Instructions de montage
 GR Οδηγίες συναρμολόγησης
 H Szerelési utasítások
 HR Upute za montažu
 I Istruzioni per il montaggio

IRL Treoracha comhdhála
 LT Montavimo instrukcijos
 LV Montāžas instrukcijas
 M Istruzioni për montimin
 NL Montagehandleiding
 P Instrukções de montagem
 PL Instrukcja montażu
 RO Instrucțiuni de asamblare
 S Monteringsanvisningar
 SK Návod na montáž
 SLO Navodila za montažo

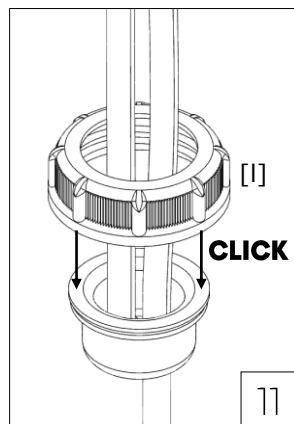
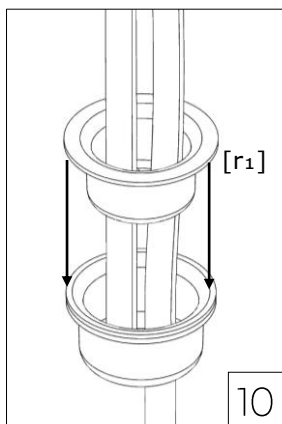
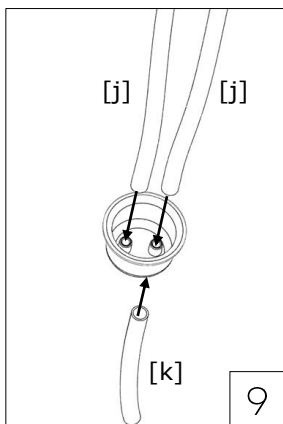
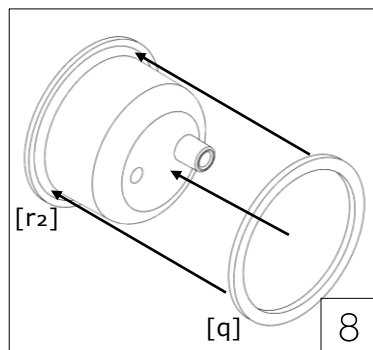
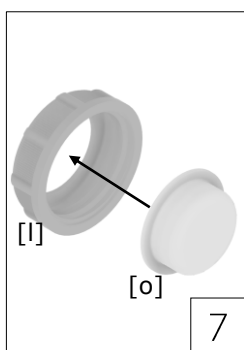
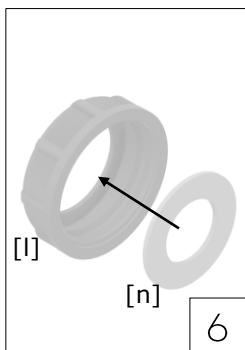
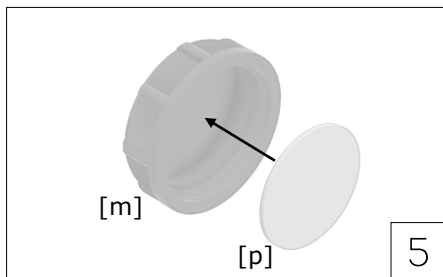
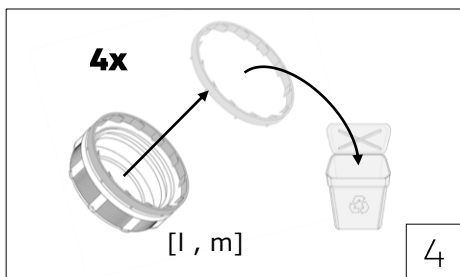

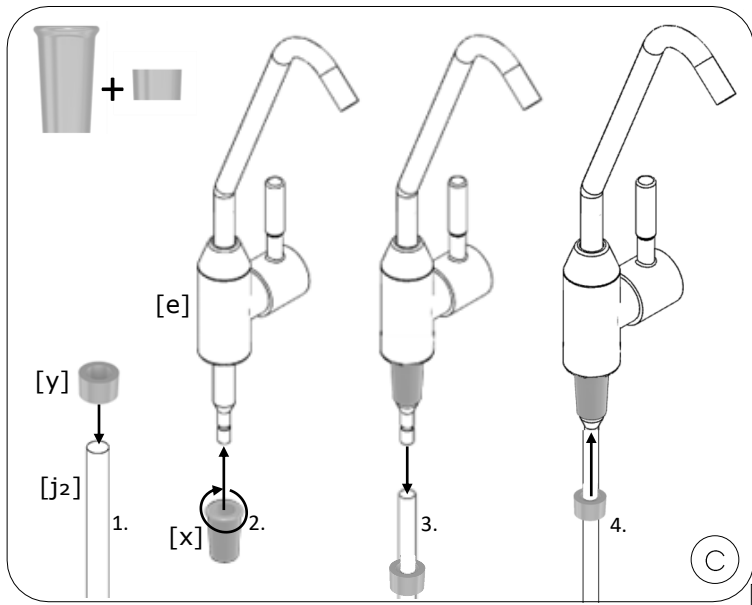
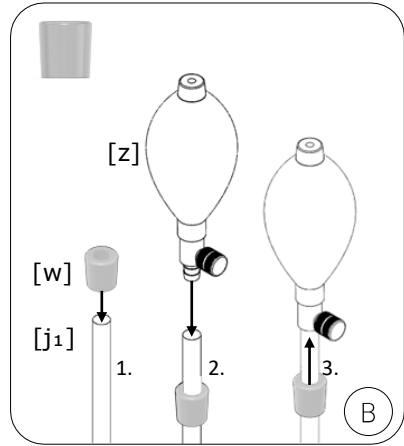
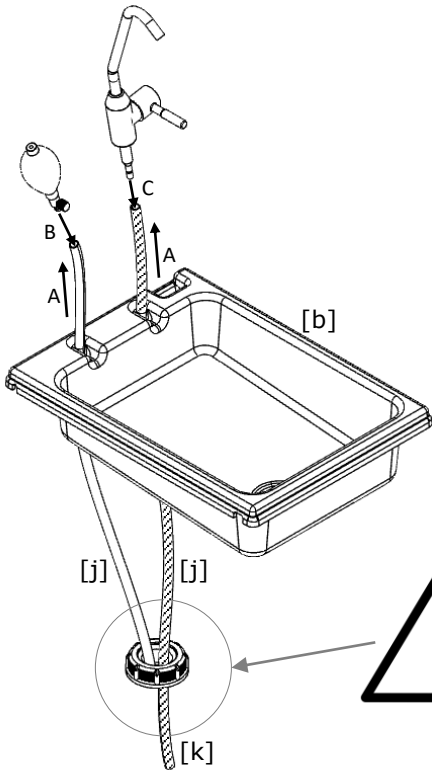

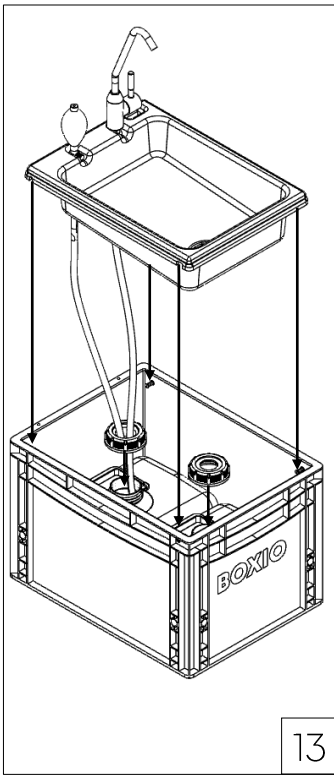

13

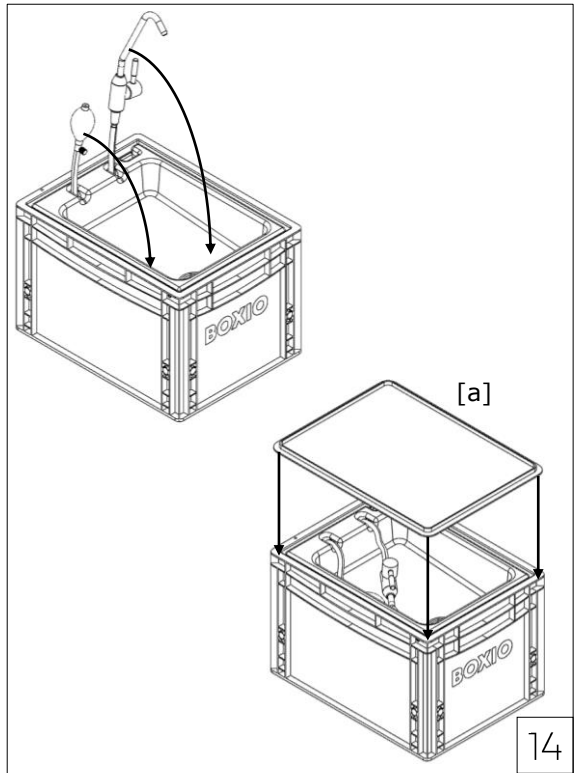

14

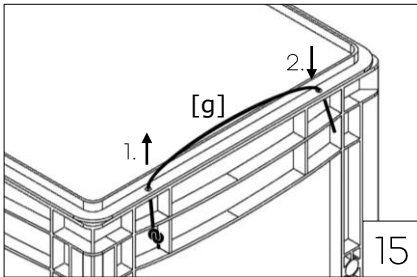

15

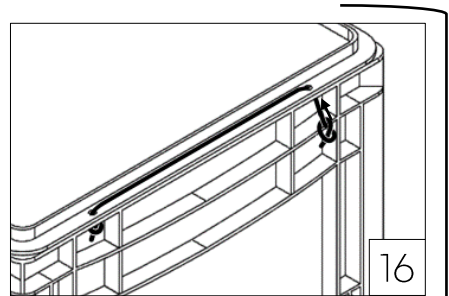

16

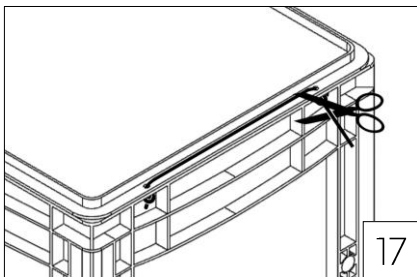

17

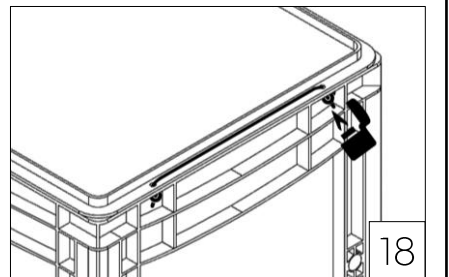

18

YOUR CHOICE

D III. GEBRAUCHSANWEISUNG BENUTZUNG DEINER BOXIO

EN III. USER`S MANUAL HOW TO USE YOUR BOXIO

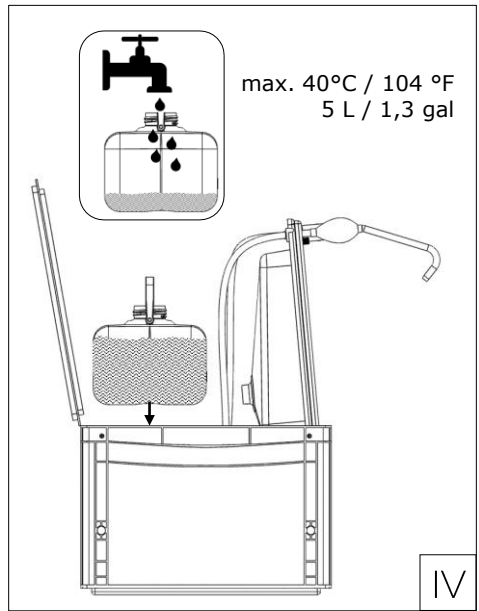
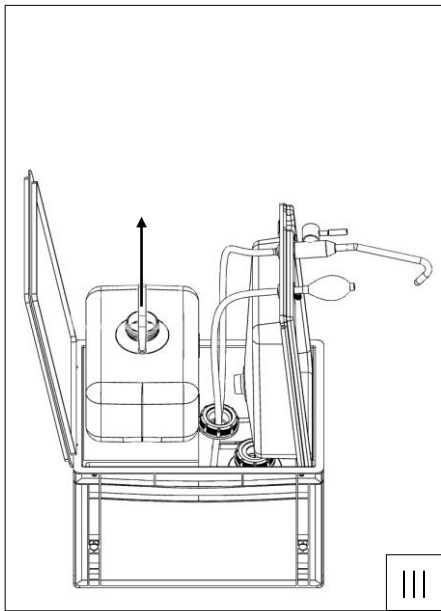
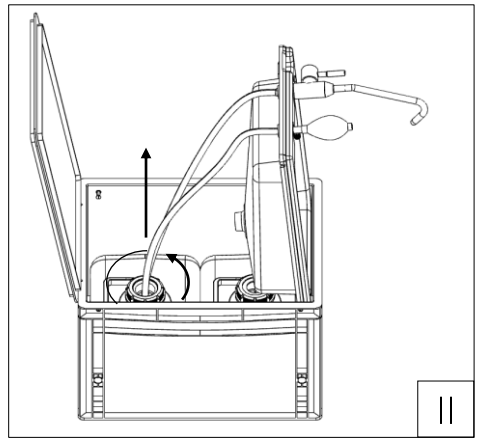
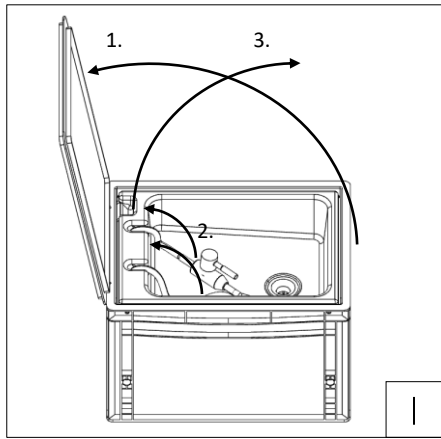

BG Ръководство на потребителя
 CZ Uživatelská příručka
 DK Brugervejledning
 ES Manual de usuario
 EST Kasutusjuhend
 FIN Käyttöohjeet
 FR Manuel de l'utilisateur
 GR Εγχειρίδιο χρήσης
 H Használati útmutató
 HR Korisnički priručnik
 I Manuale dell'utente

IRL Leabhrán úsáideora
 LT Naudotojo vadovas
 LV Lietotāja rokasgrāmata
 M Manuali tal-utent
 NL Gebruikershandleiding
 P Manual do utilizador
 PL Instrukcja obsługi
 RO Manual de utilizare
 S Bruksanvisning
 SK Používateľská príručka
 SLO Priročnik za uporabo

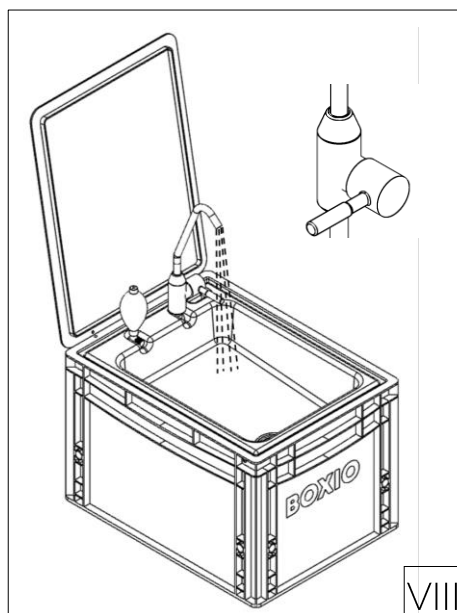
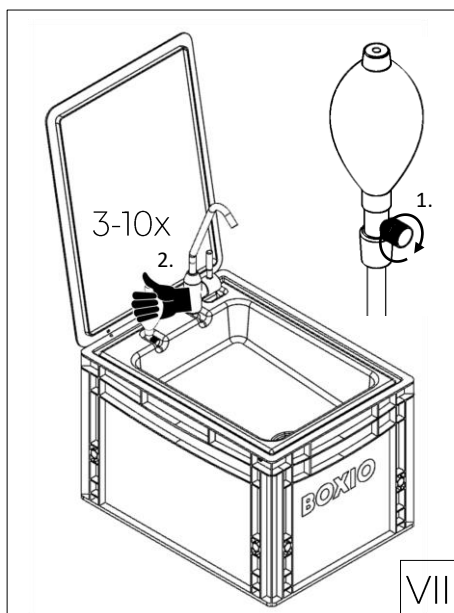
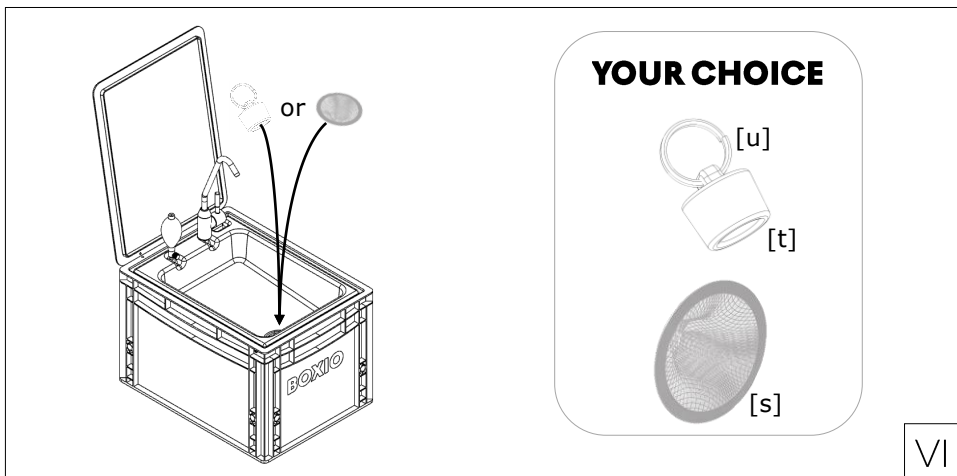

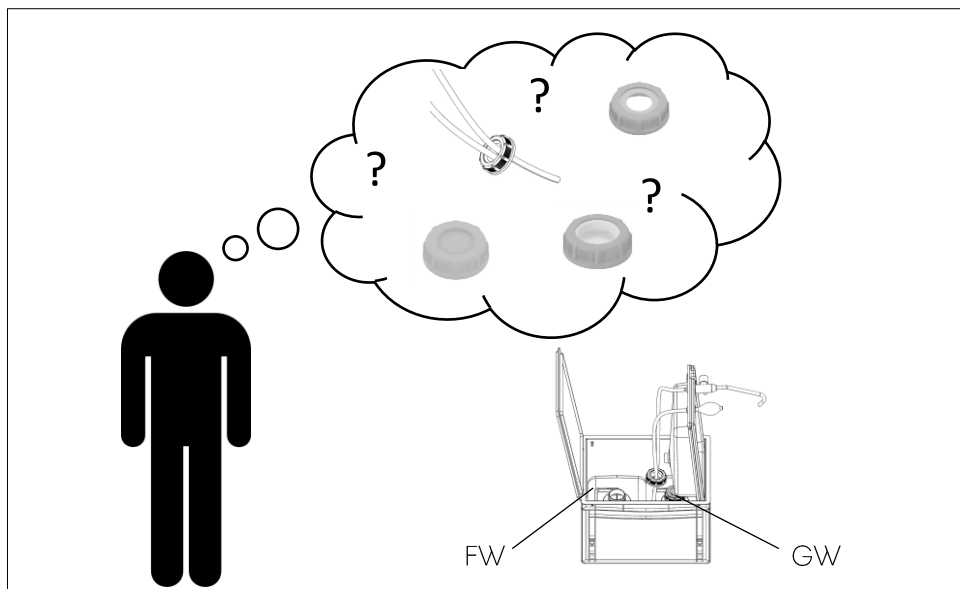

<p>ANWENDUNGSFALL USECASE</p> <p>[BG] Употреба; [CZ] Případ užití; [DK] Anvendelsesområde; [ES] Caso de uso; [EST] Kasutusjuhtum; [FIN] Käyttötapaus; [FR] Cas d'utilisation; [GR] Περίπτωση χρήσης; [H] Felhasználási eset; [HR] Korištenje slučaja upotrebe; [I] Caso d'uso; [IRL] Cás Úsáide; [LT] Panaudojimo atvejis; [LV] Lietojuma scenārijs; [M] Užu tai-kaž; [NL] Gebruiksscenario; [P] Caso de uso; [PL] Przypadek użycia; [RO] Caz de utilizare; [S] Användningsfall; [SK] Prípád použitia; [SLO] Uporabniški primer</p>	<p>FRISCHWASSER FW FRESH WATER</p> <p>[BG] Прясна вода; [CZ] Čerstvá voda; [DK] Frisk vand; [ES] Agua dulce; [EST] Värsket vet; [FIN] Makea vesi; [F] Eau douce; [GR] Φρέσκο νερό; [H] Édesvíz; [HR] Svieža voda; [I] Acqua dolce; [IRL] Uisce úr; [LT] Šviežias vanduo; [LV] Svaiga ūdens; [M] Ilma; [NL] Vers water; [P] Água doce; [PL] Woda świeża; [RO] Apă proaspătă; [S] Färskvatten; [SK] Sladká voda; [SLO] Sladka voda</p>	<p>GRAUWASSER GW GREY WATER</p> <p>[BG] Сива вода; [CZ] Šedá voda; [DK] Gråt vand; [ES] Agua gris; [EST] Halli vet; [FIN] Harmaa vesi; [FR] Eau grise; [GR] Γκριζο νερό; [H] Szürkevíz; [HR] Siva voda; [I] Acqua grigia; [IRL] Uisce liath; [LT] Pilka vanduo; [LV] Pelēkā ūdens; [M] Ilma griz; [NL] Grijs water; [P] água cinzenta; [PL] szara woda; [RO] apă gri; [S] Grått vatten; [SK] sivá voda; [SLO] siva voda</p>

- I. Scope of delivery
- II. Assembly instructions
- III. Instruction manual
 1. Introduction
 2. Usage
 3. Declaration of Conformity
 4. Safety instructions
 5. Technical data
 6. Cleaning, maintenance and storage
 7. Troubleshooting
 8. Warranty and return
 9. Additional notes

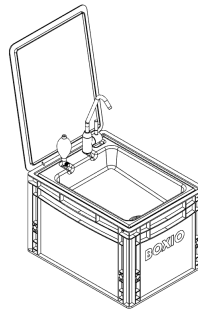

1. Introduction

Welcome to the operating instructions for the BOXIO WASH. This is a mobile sink in box format with fresh and waste water canister as well as hand pump and water tap. By means of a hand-operated air pump, an overpressure is applied in the integrated fresh water canister, which causes the water to flow when the water tap is opened. The grey water is collected below the sink in an integrated canister. In these operating instructions you will find all necessary information for commissioning, use and maintenance. Please read these instructions carefully before using the product to ensure safe and optimum use.



2. Use

This product is specially designed for camping and outdoor activities and provides a practical solution for hand or body cleaning or washing small items while traveling or during your stay in nature. However, the water from the fresh water canister should not be drunk. The product is intended for use with clean water in the temperature range 4 to 40°C [39-104 °F]. The collected grey water must be disposed of in accordance with the applicable local regulations. Applications deviating from this use are not in accordance with the intended use and may result in injury or damage.



3. Declaration of conformity

We hereby certify that the pressure-bearing components of BOXIO WASH type:T2023501 comply with Directive 2014/68/EU, Article 4, paragraph 3.

01.03.2022; Arvid Reinwaldt, M.Sc.; Duschkraft GmbH; Wertfstraße 20; 18057 Rostock; Germany

Reinwaldt

4. Safety instructions

The following points must be observed for the safe operation of the BOXIO WASH:

- Product may have sharp edges due to manufacturing process - handle and assemble with care to avoid injuries
- Use exclusively with clean fresh water in the temperature range 4-40°C [39-104 °F]
- Do not drink water from the BOXIO WASH
- Check and replace water in the BOXIO WASH regularly (every 1-3 days) to prevent bacterial growth due to stagnant water.
- no operation of the hand pump [z] in dusty environment / under water
- Mark the fresh water canister [d₁] with enclosed sticker [v], use only this canister for fresh water
- Use only closed lid [m] or the lid with canister feedthrough [r] to close the fresh water canister [d₁].
- ensure safe standing of the BOXIO WASH before use
- Careful handling and transport to avoid damage
- After use and during transport, open the air release screw of the hand operated pump [z] to depressurize the system.
- Regular cleaning and inspections for damage or leaks, replacement of damaged components.
- Avoid storage and use near heat sources, open flames or other potential sources of danger
- Do not leave BOXIO WASH in the sun and make sure that the maximum operating temperature (40°C) is not exceeded. Exceeding the permissible operating temperature can lead to scalding or material damage
- Do not exceed the maximum load capacity of the closed box of the BOXIO WASH of 100 kg. [220 lb]
- Use only original spare parts and accessories

We would like to point out that, in accordance with the Product Liability Act, we are not liable for any damage caused by our product if this damage is due to improper repair or use or the utilization of non-original components or accessories.

5. Technical data

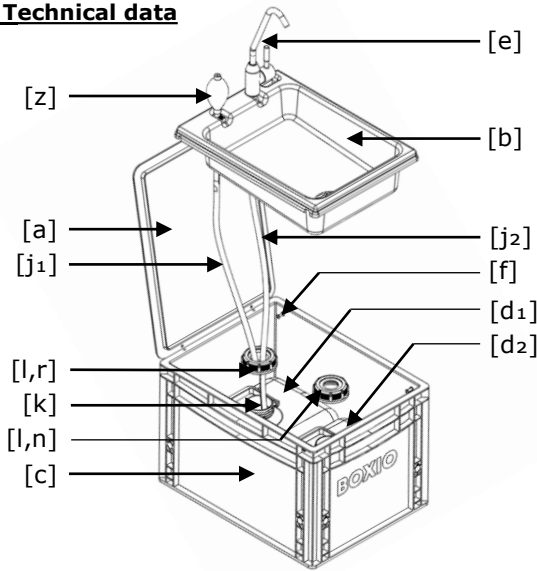

- [a] Eurobox lid
- [b] Sink insert
- [c] Eurobox
- [d₁] Fresh water canister
- [d₂] Grey water canister
- [e] Water tap
- [f] Mounting set
- [j₁] Air hose
- [j₂] Fresh water hose
- [k] Riser hose
- [l,r] Lid with canister feedthrough for fresh water canisters
- [l,n] Lid with sealing membrane for grey water canister
- [z] Hand operated pump

Product dimension (closed box)	(LxWxH) 40x30x28cm [5,7"x11,8"x11,0"]
Weight	3,8 kg [8,4 lb]
sink capacity[b]	3,5 l [0,9 gal]
Volume of fresh water canister [d ₁] / grey water canister [d ₂]	5 l / 5 l [1,3 gal / 1,3 gal]
Media to be filled	Water
Operating pressure	up to 1.3 bar [up to 18,9 PSI]
Maximum operating pressure	2 bar [29 PSI]
Pump [z]	Hand pump with integrated pressure relief valve and air release screw
Water tap [e]	Two-way valve
Minimum / maximum operating temperature	+4°C / 40°C [39 °F / 104 °F]
Materials	
Box [c] and lid [a]	PP Regenerate
Sink insert [b]	ABS Regenerate
Water tap [e]	Stainless steel 304
Hand pump [z]	Latex
Hoses [j] [k]	PVC
canister feedthrough [r]	PP
Canister [d]	HDPE
Canister lid [l], [m]	HDPE
Gaskets canister bushing/cover [n], [o], [p], [q]	Silicone (VMQ vinyl methyl silicone rubber)/ EPDM ethylene propylene diene rubber

6. Cleaning, maintenance and storage

Component	Cleaning	Maintenance
Fresh water canister[d ₁]	Regular cleaning of the canister e.g. with bottle brush and detergent, remove residues of detergent with sufficient water.	Regularly check for damage. If damage occurs, the BOXIO WASH should not be used. Damaged parts must be replaced due to risk of injury.
Hand pump [z], water tap [e], hoses [j], [k], canister feedthrough [r].	Regular external cleaning with a dishwashing detergent and a cloth, remove the residues of the dishwashing detergent with sufficient water. While cleaning the pump ball, make sure that no water gets inside the pump.	
Eurobox [c], lid [a] sink insert [b]	Wipe damp with soft cloth and mild detergent	
greywater-Canister [d ₂]	Rinse when empty, clean with mild detergent if necessary	

Storage:

All parts can be stored well dried and cleaned inside the box [c]. Flush hoses [j], [k] with sufficient water before putting them back into operation. Avoid storage near heat sources, open flames or other potential hazards. Avoid direct exposure to sunlight.

7. Troubleshooting

Error	Cause	Solution
Water does not flow when opening the tap	Air release screw from the hand pump [z] is open	Tightening the air release screw
	No pressure on the fresh water canister [d ₁].	3- 10 times pump
	Fresh water canister [d ₁] is empty	Fill canister
	Cap of fresh water canister[d ₁] not tightened properly	Tighten the closure
	Seal from fresh water canister [d ₁] not inserted or not inserted correctly	Check correct seating of the seal
	Hoses [j] of water tap [e] and air pump [z] mixed-up	Check hose routing and replace if necessary
	Hose [j] is twisted, kinked or damaged	Check hose routing
	Hoses [j] do not sit properly on components	Check the correct fit of the hoses
Bubbling can be heard during pumping	Hoses [j] of water tap [e] and air pump [z] mixed-up	Check hose routing and replace if necessary
	Water runs into the Eurobox/ does not drain from the sink	
Water runs into the Eurobox/ does not drain from the sink	grey water canister [d ₂] is too full	Empty grey water canister [d ₂].
	canister cap is closed	Replace fuel cap with open cap
sink-insert does not close properly	Hoses are twisted or clamped	Check hose routing and arrange if necessary

8. Warranty and return

We hope that you are as satisfied with our BOXIO products as we are. If this should not be the case, you have of course the possibility to send them back to us in an uncomplicated way.

Warranty conditions

BOXIO WASH comes with a two-year warranty from the date of purchase. This warranty covers all manufacturing defects and material defects. If your BOXIO WASH has a defect within this period, please contact us immediately at support@boxio-shop.de so that we can correct the defect. Please note that the warranty does not cover damage caused by improper handling, misuse or neglected maintenance.

Returns

You have the right to revoke the purchase contract within fourteen days without giving any reason. The withdrawal period is fourteen days from the day on which you or a third party named by you, who is not the carrier, have taken possession of the goods. To arrange a return, please use our returns portal or your retailer's returns portal.

9. Additional notes

For your own safety and to avoid mixing up the canisters, please mark them with the enclosed stickers:

Fresh water canister

MFD/Bj.	2023
V	5 l / 1,32 US gal
T min	4°C / 39,2°F
T max	40°C / 104°F
p	≤ 1,3 bar / ≤ 18,8 psi

BOXIO by Duschkraft GmbH
Werftstr. 20, 18059 Rostock, Germany

[V1]

Gray water canister [gray]

[V2]

Urine canister of your BOXIO TOILET [yellow]

[V2]

Rev. date: 30.03.2023

BOXIO®

DUSCHKRAFT GmbH, Werftstrasse 20, 18057 Rostock, GER

© 2023, **BOXIO, Made in Germany**

