

Kaleido® SNIPER M1

Instruction Manual

Straight fire coffee bean roaster

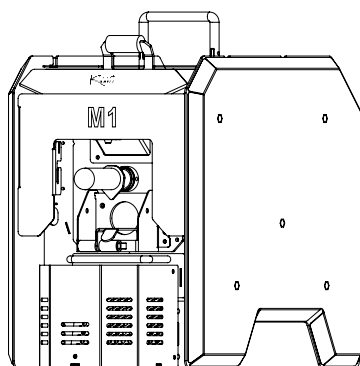

Catalog

Safety Alert ----- Prohibited, Mandatory, Precautions	2
Product Overview	3
Installation Instructions	3
Performance parameter table	4
Maintenance and replacement parts	5

Thank you very much for purchasing Kaleido products.

- Please read this manual carefully to ensure the correct and safe use of this product.
- Please carefully read the "Important Notes" and "Safety Warnings" (Page 2) before use.
- Please keep this manual properly for future use.
- Kaleido will not be responsible for improper operation of this product or failure to follow the relevant instructions.

**Warranty certificate
attached separately**

Important note:

The following problems will occur due to the inevitable falling of articles during transportation:

Please be sure to confirm receipt after unpacking inspection. If the shell is bumped, contact customer service to send a new shell. (If the paint is knocked off in special parts, contact the customer service to replace the machine)

When the machine is received, the heating pipe does not work in two cases:

1. The heating tube glass tube is broken due to the vibration during logistics transportation, and the heating tube cannot work.
2. The heating wire is broken due to vibration during logistics transportation, and the heating pipe cannot work after 1-3 times of using the machine.



warning

In order to ensure the safety of use and avoid causing injury and property loss to you and others



- Safety warnings must be learned. It is forbidden for non learners to operate the baking machine. Children should stay away from the baking machine. Do not open the rear cover plate when power is on. Non professionals shall not carry out live maintenance. When replacing accessories, unplug the power plug before opening the rear cover plate. Only after the replacement is completed can the machine be plugged in and tested.
- Over roasting of coffee beans is prohibited.
- Do not wet the power socket with water.
- Please do not leave during roasting! Avoid excessive heating and burning of coffee beans due to no supervision.
- **When heating, the bean bin must be stirred**, otherwise the bean bin will be deformed due to excessive heat on one side.
- The set bean temperature should not exceed **230** degrees.
- The silver peel of coffee beans collected should be cleaned in time to avoid burning due to the accumulation of silver peel.



- The device must be placed in a well-ventilated place, and no flammable materials behind. Do not cover the **exhaust vents**.
- During the baking and heating, the surface temperature of the equipment is high. Do not touch the surface of the device to avoid burns. **(The red area is the high temperature area)**
- After roasting is completed, **stirr the bean cabin** and **turn on the exhaust smoke**. And turned off the roaster after temperature of the beans drops **below 50 degrees**.
- The new equipment will have some smell of the spray paint, and it will dispel after baking **2-3** times.

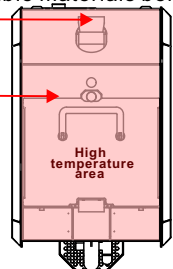

Product Overview

Top view

Right view

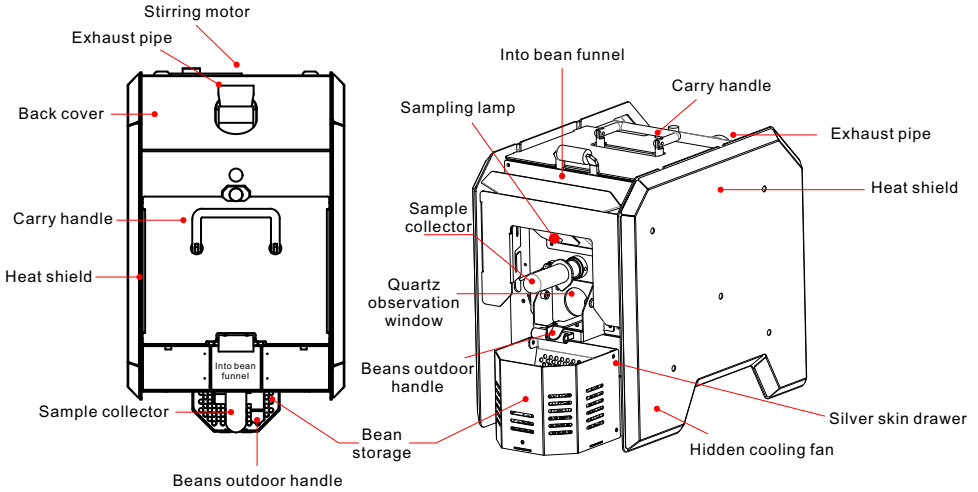

Installation Instructions

Coffee roaster installation and upper cover and rear cover removal

1. After open the package, M 1 does not need to be installed, just connect the touch screen and USB connector. And power on then you can use it.
2. Remove the back cover, just remove one screw.

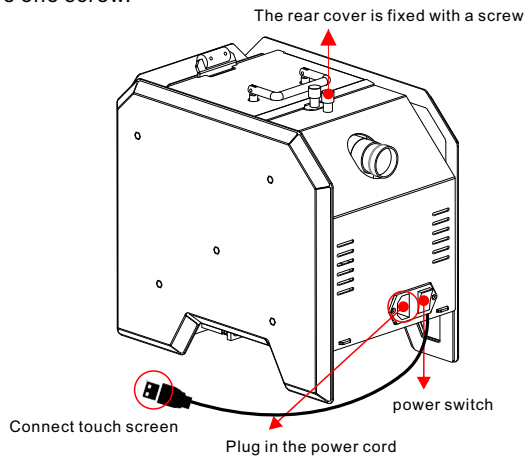

Performance parameter table

M1 is compact, powerful and integrates with many new technologies. It is a powerful weapon for roasting coffee beans.

Scope of application: [sample bean roasting](#), [cup test roasting](#), [fine coffee bean roasting](#), [coffee training and teaching](#), [coffee shop self-use and sales](#), [bean roasting](#), [various coffee places](#), etc.

Capacity description

Baking capacity / single	Design optimum capacity 50g-150g, up to 200g.
Baking volume per hour	Up to 800g.
Baking degree	Extremely light baking / light baking / medium baking / Italian combination, etc., can be arbitrarily baked.
Baking time	6-12 minutes.
Suitable beans	wet coffee beans , various types of dry coffee beans, hard beans, aged beans.

Technical parameter

Product number	 — SNIPER M1
Heating method	Electric heating: Imported carbon fiber infrared electric heating tube.
Heating power (adjustable)	110V~220V, heating power 600W, total equipment power 650W.
Boiler (adjustable speed)	Patent. Stainless steel 304 boiler, adjustable boiler speed.
Heating capacity	The surface of the heating tube is instantaneously 500 degrees at once.
Air damper (adjustable)	Electronic air damper, touch screen to adjust the air volume.
Cooling	Independent cooling system, rapid cooling in 2 ~ 3 minutes.
Silver skin collection	Patent. Automatic silver skin collection system, no traditional silver skin collector.
Operation mode	Full touch screen operation. Without any industrial buttons.
Product size and weight	300 * 199 * 274 (length, width and height) Net weight: 12KG.
Safety protection	heating tube 220V(or 110V), all other components 12V. Double safety protection: anti-leakage safety plug + internal temperature upper limit to stop heating protection.

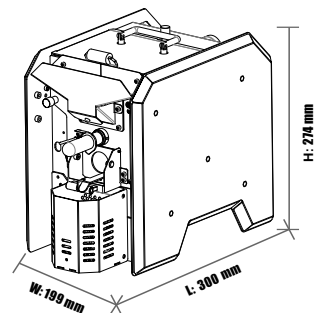

Maintenance and replacement parts

M1 is very easy and simple to maintain.

Daily maintenance: Clean the tiny silver skin and dust remaining in the boiler.
Clean deflated beans and crushed beans on the bean bin grid!

1.

Pull the front panel up and out.

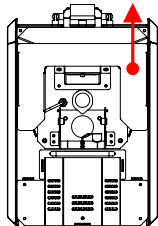

2. Remove the two screws from the front panel.

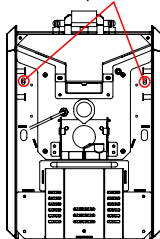

3. Remove one screw from the upper cover.

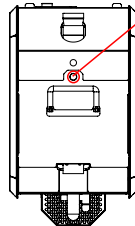

4. Stand the handle up and take out the red iron sheet.

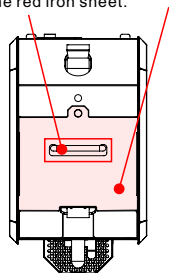

5. Lift off heat shield.

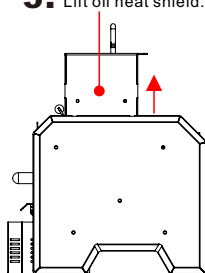

6. Tilt the machine and remove the two screws from the side plate. And remove the side plate.

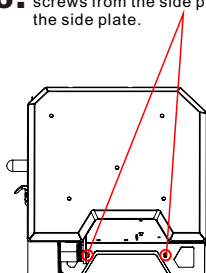

7. Use a small brush to clean the tiny silver skin and dust remaining in the boiler.
Clean deflated beans and crushed beans on the bean bin grid!

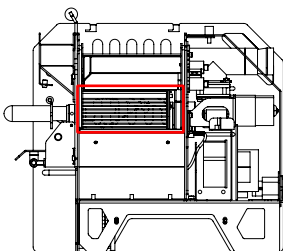

Heating tube replacement:

If the heating tube reaches the service life. (5000-8000 hours life)

You can Remove the screws of the back cover on the top of the machine and remove the back cover.

Loosen the two nuts of the heating tube, disconnect the heating tube connection

You can remove the old heating tube and install the new one.

Tighten the two nuts and connect the wire, then it is ready to use.

The heating tube wire no have positive or negative.

The rear cover is fixed with one screw.

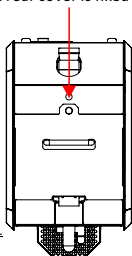

Unscrew the two nuts of the heating pipe and replace the heating pipe.

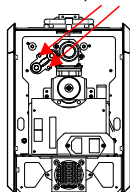

Warning:

For maintenance or replacement of accessories, the plug must be unplugged before operation.