



These instructions and the images herein are proprietary. Any unauthorized reproduction is prohibited.

GW-V-TOP-LOAD

Pop-Top Load Assist for Vanagon Westfalia

This kit is designed to provide two levels of lifting assistance. The **forward position is designed for loaded tops** and offers approximately 130lbs of lifting assistance at the lifting gear. When using the forward position with an unloaded top, you will have to PULL DOWN with about 100lbs of force to close the top, so if you typically have an unloaded top you should consider the rear position. As the top closes, the struts go from a roughly 45 degree upright angle to roughly flat, and their assist goes to zero—so once it is most of the way down, it is easy to fully close the top. The **rear position is designed for lightly loaded tops** and makes raising and lowering the top a breeze. You can order extra brackets, install them in both positions, and then just move the struts where they need to be depending on roof loads.

IMPORTANT: The struts arrive with locking sleeves installed, which lock the strut into place when fully extended. Because the struts sit outside the tent on a Vanagon, this feature is undesirable. To undo the locking feature (but keep the sleeves installed to act as dust guards), simply rotate the red plastic button piece 180° (see diagram at right) to allow the cylinder to slide freely into the sleeve when compressed (it is glued in place so some force may be needed to break it free). Alternatively, you can remove the sleeve entirely by unscrewing the end fitting, sliding the sleeve off, and reinstalling the end.

DISCLAIMER: This kit has been designed for easy installation. However, it does involve drilling into both the body and top of your vehicle. The installation of this kit is not within everyone's ability. Read through these instructions carefully and decide if installing it is for you. If not, please take your vehicle to a qualified automotive specialist.

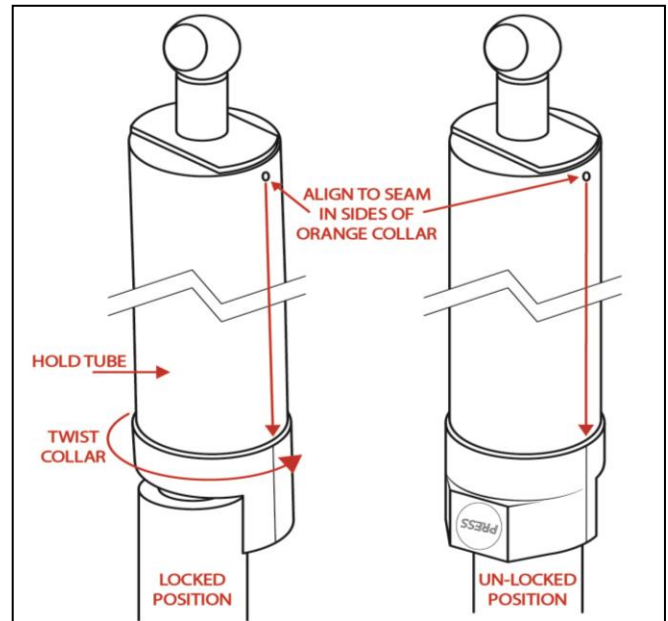

Contents of Kit

(2) Struts	(4) Rivet Nuts
(4) 6 x 20mm SS Bolts	(4) 6 x 45mm SS Bolts
(4) 6 x 18mm SS Washers	(4) SS Nylock Nuts
(4) Brackets	(1) RIVNUT-BOLT-TOOL
(1) Packet Antiseize	

Tools Required

- 10mm Wrench	- Ratchet w/10mm Socket
- Electric Drill	- 25/64" and 15/64" Drill Bits
- Small Flat Screwdriver	- Silicone Sealant

Installation

Mounting Lower Brackets to Body

- 1) First, decide which mounting position fits your needs. With the top open you will see bulges/ribs on the body along the tent/body junction (see diagram below). The rib closest to the pop-top hinge is the **rear** location (**LESS** assist) and the next rib forward is the **front** location (**MORE** assist).
- 2) Attach both mounting brackets to the struts in order to test fit where the top brackets contact the pop-top when installed (see diagram below for correct bracket positioning— the strut side faces *out* at the bottom and *in* at the top). There is a small chance that the top brackets may interfere with the screws in the aluminum tent strips on 1985-91 vans. This is especially important when using the rear position with a GoWesty rainfly also installed (or potentially installed). The front snap location for the rain fly is close to the upper bracket mounting location, and while we have not had any issues with interference we want you to confirm fitment before installing, as there is some variability in the relative position of the pop-top to the body from van to van. If you do experience any issues, the brackets on the body can be positioned slightly fore or aft on the body to fine-tune the positioning.



These instructions and the images herein are proprietary. Any unauthorized reproduction is prohibited.

GW-V-TOP-LOAD Pop-Top Load Assist for Vanagon Westfalia

- 3) With the lower bracket position confirmed, remove the bracket from the strut and place it on the body rib as shown in the diagram below (use a small flat blade screwdriver to pry the clip out from the end of the strut to release it from the bracket). The bracket should be flush with the body and the tent rail with the ball mount portion of the bracket facing **away** from the tent.
- 4) Mark the center of each mounting hole and drill out with a 25/64" drill. It is advisable to use a center punch to mark the location and drill a pilot hole using a small ($\approx 1/8"$) drill bit. **NOTE: The forward mounting position has two layers of metal approximately 1/4" apart and you need to drill through BOTH layers.**
- 5) Apply some silicone sealant to the edge of the hole and install the rivet nuts using the included RIVNUT-BOLT-TOOL (instructions for use are included with the tool). Tighten the rivet nut so that it is firmly seated but do not tighten it completely using the tool for the final seating. Instead, use the bracket hardware to tighten the rivet nut while installing the bracket.
- 6) Apply some silicone to the bottom and top of the bracket holes and install using the included 6mm x 20mm stainless steel bolts and washers. Tighten until snug. Make sure to apply antiseize to your included stainless-steel hardware.

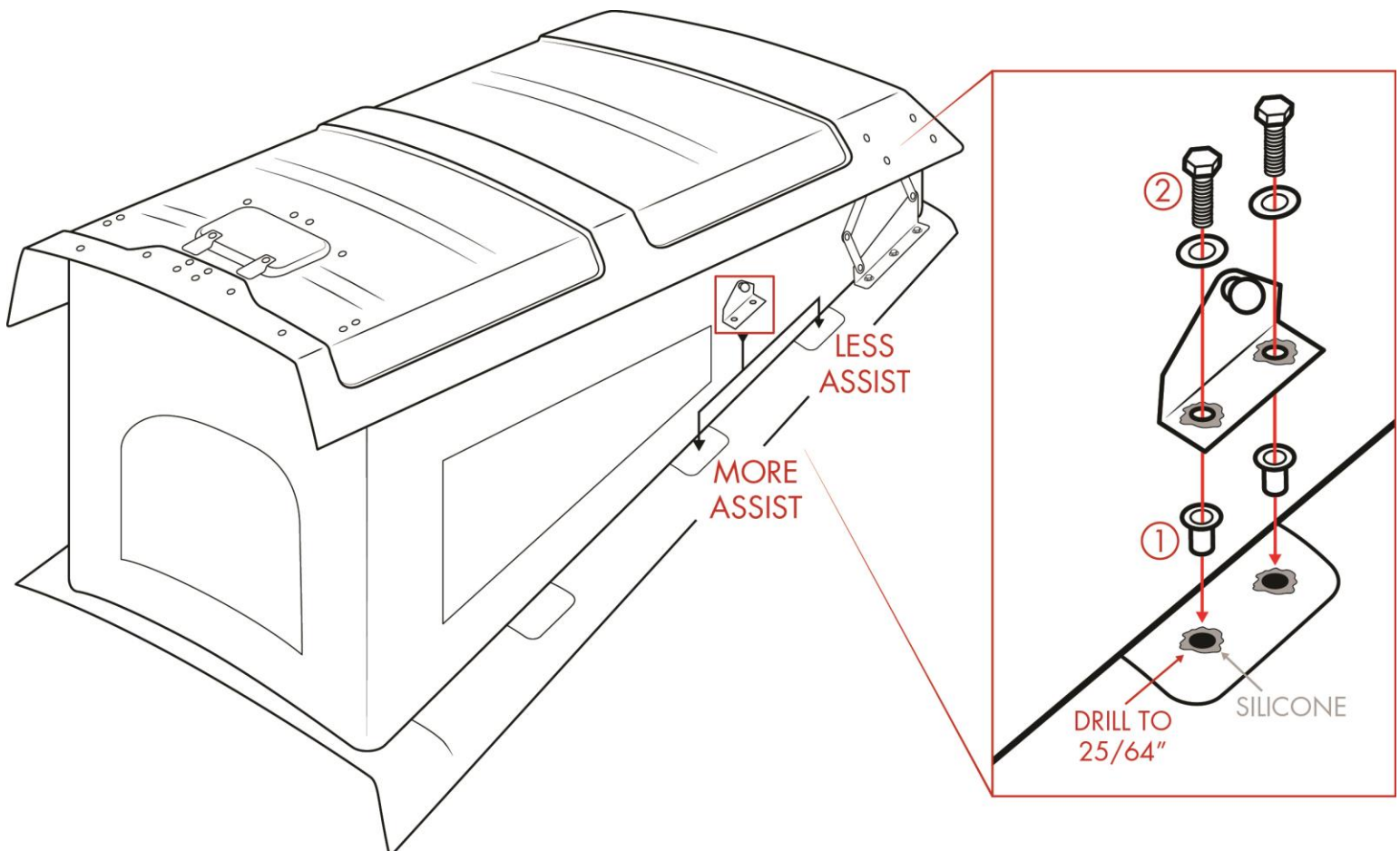



GW-V-TOP-LOAD

Pop-Top Load Assist for Vanagon Westfalia

Mounting Upper Brackets on Pop-Top

- 1) Attach the piston side (skinny end) of the strut to the lower bracket and mount the upper bracket to the other end. The upper bracket should be positioned 180° from the lower bracket, with the strut side facing towards the tent. Swing the strut and bracket up into place.
- 2) For vans with screw-in style tents (85-91) position the bracket, centered directly on the aluminum strip that holds the tent to the top (see diagram below). Mark the center of each mounting hole with a center punch and drill a pilot hole using a small ($\approx 1/8''$) drill bit. It is VERY important to drill the hole **straight** up through the top to ensure the holes come out on the flat of the roof. Working from the *outside* in, drill the hole out to its final dimension of 15/64". It is recommended that you drill the first hole, fasten the bracket, then drill the second hole while the bracket is installed. This will guarantee that the holes will be aligned. This is to prevent potential splintering of the fiberglass top as you push through with the drill bit. Make sure to apply antiseize to your included stainless-steel hardware.
- 3) For vans with staple-in style tents (80-84) position the bracket, flush with the inboard edge (towards the tent) of the wood strip the tent is stapled (see diagram below). NOTE: It is extremely IMPORTANT that the bracket is installed flush with the inboard edge and that you drill the hole **straight** up through the top. This is to ensure the hole comes out on the flat of the roof and not the curved edged. Mark the center of each mounting hole with a center punch and drill a pilot hole using a small ($\approx 1/8''$) drill bit. Working from the *outside* in, drill the hole out to its final dimension of 15/64". It is recommended that you drill the first hole, fasten the bracket, then drill the second hole while the bracket is installed. This will guarantee that the holes will be aligned. This is to prevent potential splintering of the fiberglass top as you push through with the drill bit. Make sure to apply antiseize to your included stainless-steel hardware.



These instructions and the images herein are proprietary. Any unauthorized reproduction is prohibited.

GW-V-TOP-LOAD

Pop-Top Load Assist for Vanagon Westfalia

- 4) Install the 6mm x 45mm stainless bolts through the top using the stainless washers between the bolt and top. Apply silicone sealant between bolt head and washer as well as between the washer and top to ensure a weather tight seal. Install brackets and thread the nylock nuts onto the bolts and tighten down until snug. Install strut to top bracket if you removed it to install bracket to top. Make sure to apply antiseize to your included stainless steel hardware.

