



These instructions and the images herein are proprietary. Any unauthorized reproduction is prohibited.

## Westfalia Poptop Seal Kit Installation Guide 1974-91 VW Bus & Vanagon Campers

### Pop-Top Seal

With the pop-top open, pull off the stock seal and clean the now exposed edge of the top. New seal installation is as follows.

1. Press the U-shaped channel onto the edge of the pop-top, with the bulb facing inboard toward the tent. Use a mallet and block of wood to tap the seal onto the rack if necessary. Trim the seal  $\frac{1}{2}$ " from the pop-top front edge of both sides.
2. Apply glue to both the front edge of the pop-top and inside the rounded groove of the flat seal, and allow glue to become tacky.
3. With the glue tacky, press the flat seal on the front edge of the pop-top, and trim the excess on both ends to be even with the U-shaped seal. Allow glue to fully cure for 2 hours before closing top.

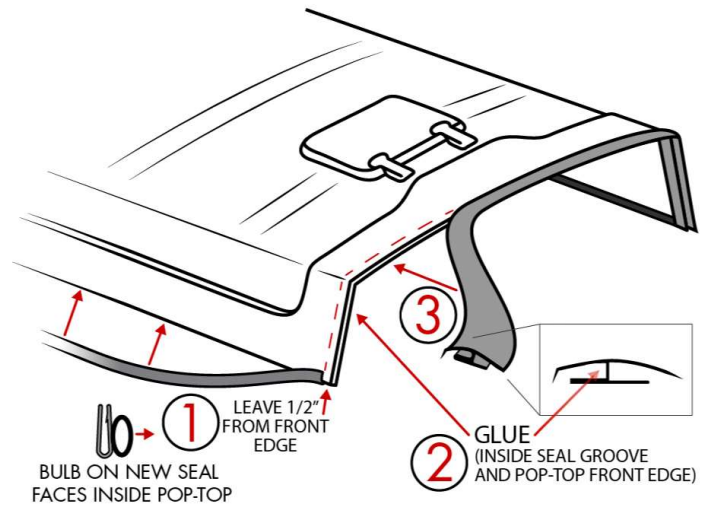

GoWesty Camper Products • 1119 Los Olivos Ave, Los Osos, CA 93402 • 888-469-3789 • [www.gowesty.com](http://www.gowesty.com)



These instructions and the images herein are proprietary. Any unauthorized reproduction is prohibited.

## Westfalia Poptop Seal Kit Installation Guide 1974-91 VW Bus & Vanagon Campers

### Pop-Top Seal

With the pop-top open, pull off the stock seal and clean the now exposed edge of the top. New seal installation is as follows.

1. Press the U-shaped channel onto the edge of the pop-top, with the bulb facing inboard toward the tent. Use a mallet and block of wood to tap the seal onto the rack if necessary. Trim the seal  $\frac{1}{2}$ " from the pop-top front edge of both sides.
2. Apply glue to both the front edge of the pop-top and inside the rounded groove of the flat seal, and allow glue to become tacky.
3. With the glue tacky, press the flat seal on the front edge of the pop-top, and trim the excess on both ends to be even with the U-shaped seal. Allow glue to fully cure for 2 hours before closing top.

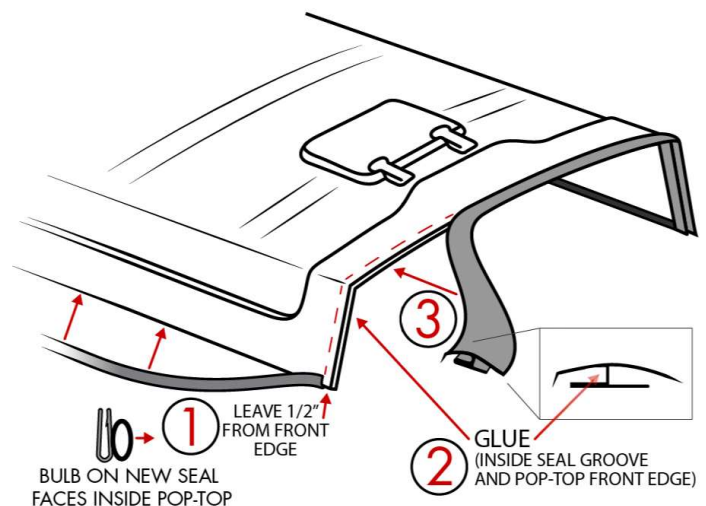

GoWesty Camper Products • 1119 Los Olivos Ave, Los Osos, CA 93402 • 888-469-3789 • [www.gowesty.com](http://www.gowesty.com)