

8 Passo
Paso
Step

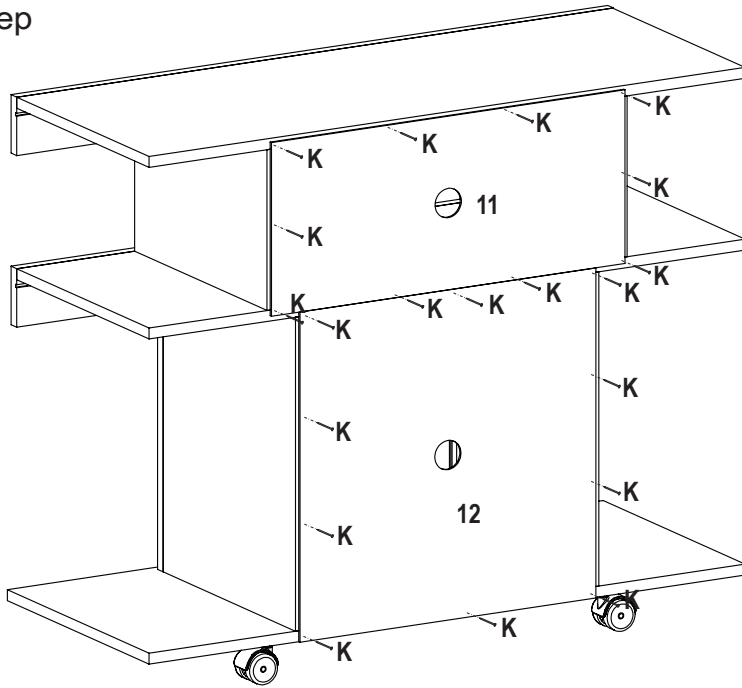

Rödler

www.rodler.cl

Manual de Armado

Manual del Producto
User's Guide



Rödler

www.rodler.cl

Rack Guaíba

Rack Guaíba / Guaíba Rack

Versão 1.0 / Versión 1.0 / Version 1.0

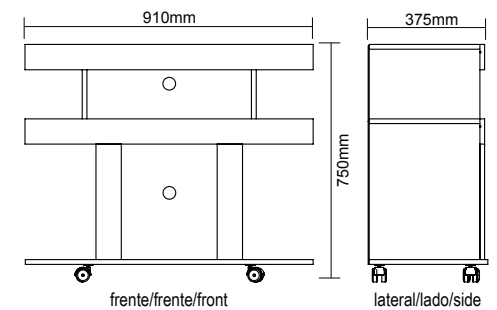
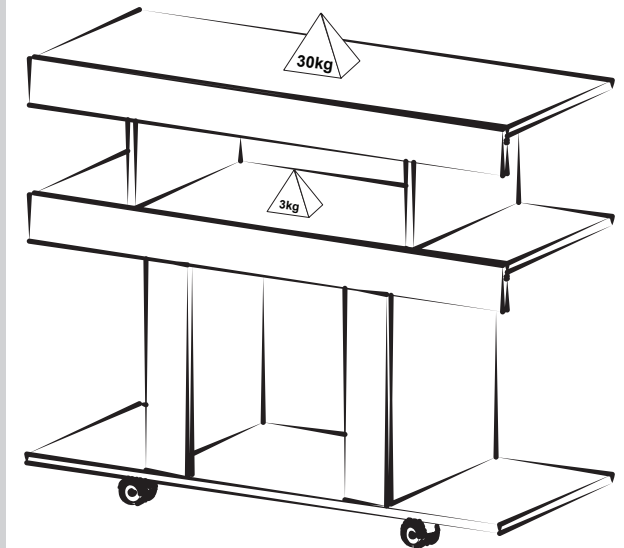

Siga com atenção as instruções de montagem.
Siga con atención las instrucciones de montaje.
Proceed with attention the assembling instructions .

Conservação e Limpeza

Conservación y Limpieza Conservation and Cleaning

Não expor o produto ao sol, altas temperaturas e umidade. Não arrastar objetos sobre a superfície do móvel (ex.: TV, DVD, aparelho de som, objetos decorativos...) e manter em local seco e arejado.

Para a limpeza, utilizar um pano seco e macio. Não é necessário o uso de materiais abrasivos ou álcool.

No exponga el producto a la luz solar, las altas temperaturas y la humedad. No arrastre los objetos a través de la superficie de la unidad (por ejemplo, TV, DVD, equipo de música, objetos de decoración ...) Mantener en un lugar fresco y seco.







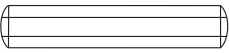
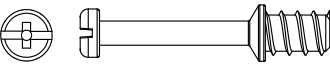
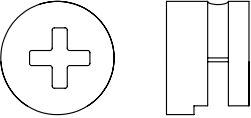

Para la limpieza, utilizar un paño seco y suave. El uso de materiales abrasivos o del alcohol no es necesario.

Do not expose the product to sunlight, high temperatures and humidity. Do not drag objects across the surface of the unit (TV, DVD, stereo, decorative objects ...) keep it in a cool dry place.

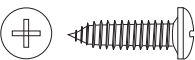
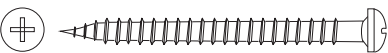
For cleaning, use a dry and soft cloth. Do not use abrasive materials or alcohol.

Lista de Materiais

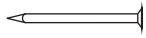
Lista de Materiales/ Hardware List

A		Cavilha / Tarugo / Dowel Ø6x30mm	16
B		Minifix Minifix / Minifix Ø7x30mm	08
C		Tambor / Tambor / Minifix Cam Ø15x12mm	08
D		Tapa furo adesivo / Adhesivo / Hole Cover Ø18mm	08
E		Parafuso / Tornillo / Screw Ø4,0x14mm CP	28
F		Parafuso / Tornillo / Screw Ø3,5x40mm CP	08
G		Chapa Reta / Placa Recta / Mending Plate 50x13mm	02
H		Suporte Angular Soporte Angular / Plastic Corner Brace 24x16x13mm	12
I		Bucha / Casquillo / Bushing Ø30x16mm	04
J		Rodizio RF40 s/ trava Rueda RF40 sin traba / RF40 Caster without lock 60x40mm	04
K		Prego / Clavo / Nail 8x8	20
L		Cola / Pegamento / Glue	01

6 Passo Paso Step

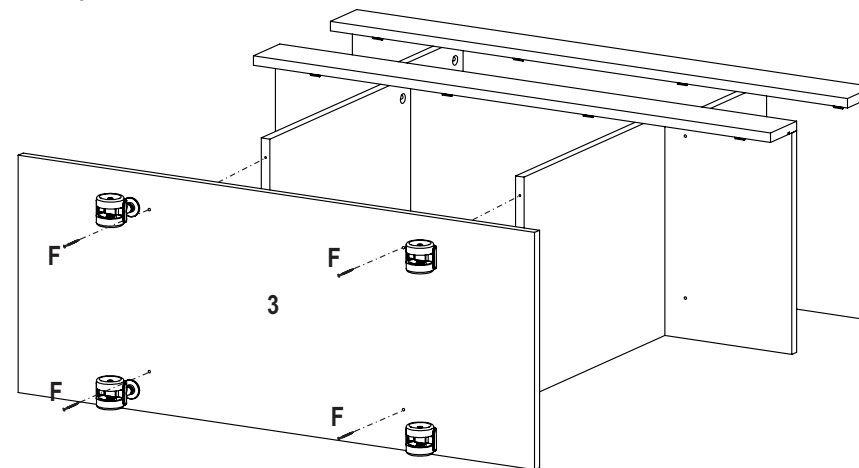

7 Passo Paso Step

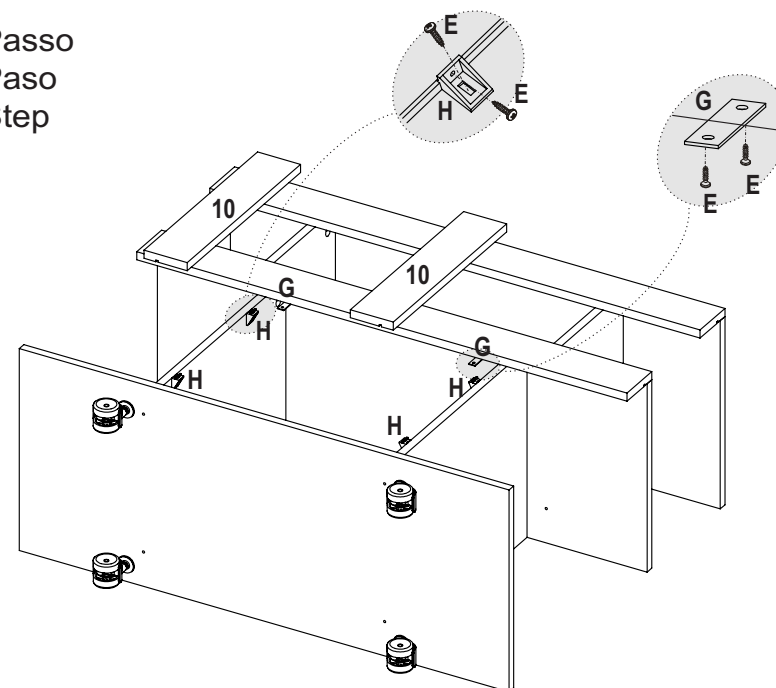

4 Passo
Paso
Step

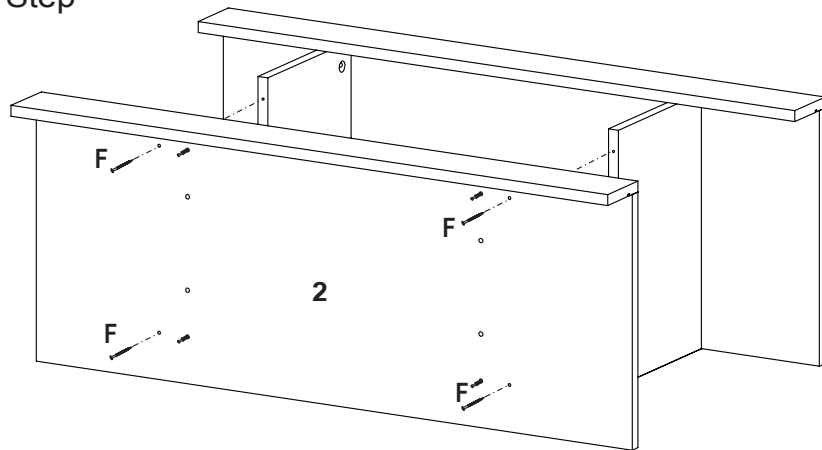

5 Passo
Paso
Step

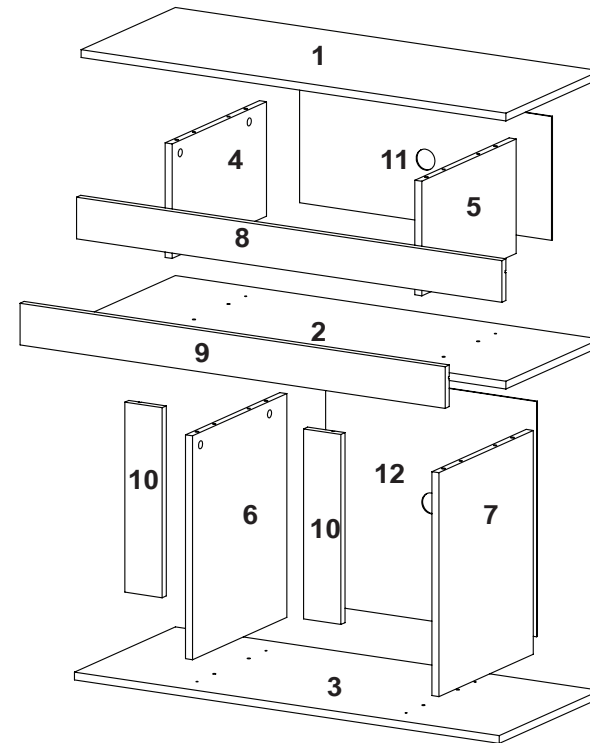
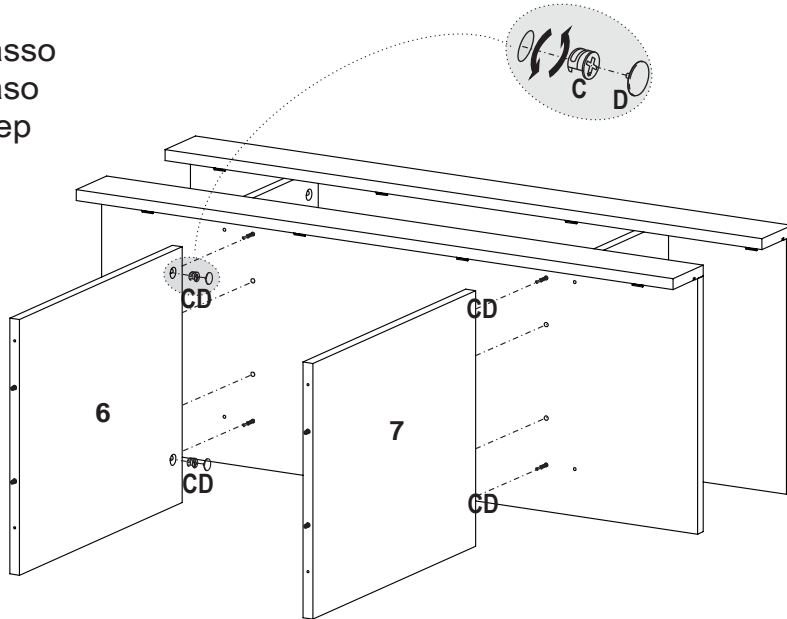

Denominação	Qty
1-Tampo (910x350x15mm)	1
2-Tampo Central (910x350x15mm)	1
3-Base (910x375x15mm)	1
4-Lateral esquerda superior (220x350x15mm)	1
5-Lateral direita superior (220x350x15mm)	1
6-Lateral esquerda inferior (430x350x15mm)	1
7-Lateral direita inferior (430x350x15mm)	1
8-Encabeçamento maior tampo (911x80x15mm)	1
9-Encabeçamento maior tampo central (911x80x15mm)	1
10-Encabeçamento menor (365x80x15mm)	2
11-Traseira superior (238x540x3mm)	1
12-Traseira inferior (452x452x3mm)	1

Denominación	Description
1-Tapa	1-Top
2-Tapa central	2-Central top
3 -Base	3-Base
4-Lateral izquierda superior	4-Upper left side
5-Lateral derecha superior	5-Upper right side
6-Lateral izquierda inferior	6-Lower left side
7-Lateral derecha inferior	7-Lower right side
8-Encabezado mayor tapa	8-Top bigger header
9-Encabezado mayor tapa central	9-Central top bigger header
10-Encabezado menor	10-Small header
11-Traseira superior	11-Upper back
12-Traseira inferior	12-Lower basck

Fixação do Minifix e Tambor



SIGA COM ATENÇÃO AS INSTRUÇÕES DE MONTAGEM.
SIGA CON ATENCIÓN LAS INSTRUCCIONES DE MONTAJE.
PROCEED WITH ATTENTION THE ASSEMBLING INSTRUCTIONS .

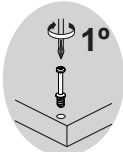
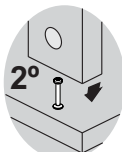
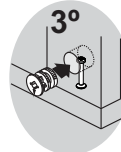
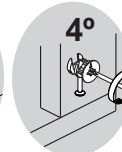
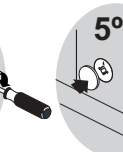



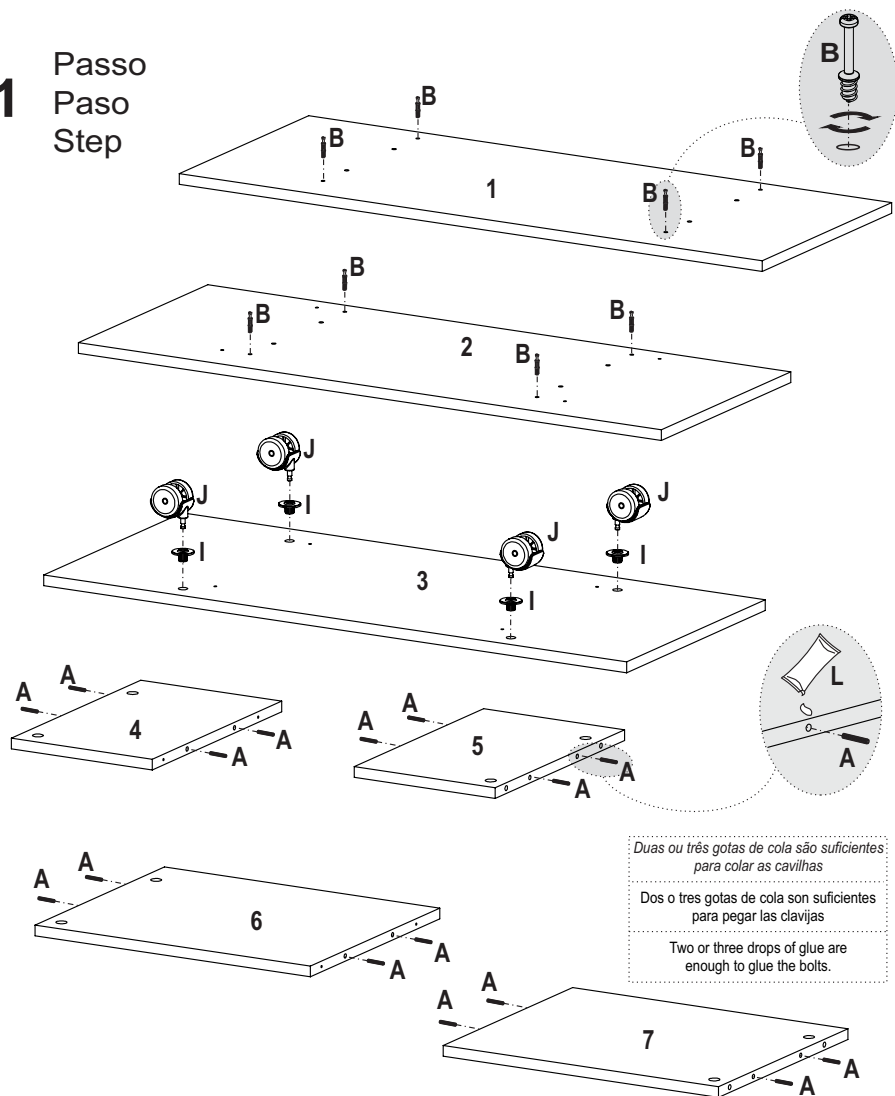

1º Minifix
 2º Peça
 3º Tambor
 4º Tambor
 5º Tapa Furo Adesivo

1 Passo
 Paso
 Step

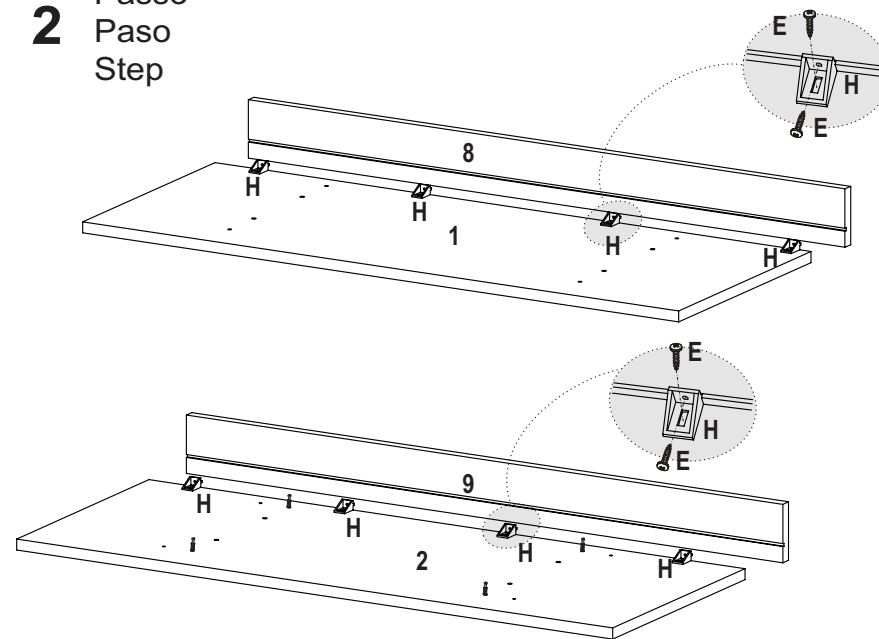

2 Passo
 Paso
 Step



3 Passo
 Paso
 Step

