

Mesa operacional 1400 - Y 37

Ref.: 2204 - 5025

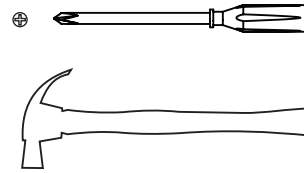
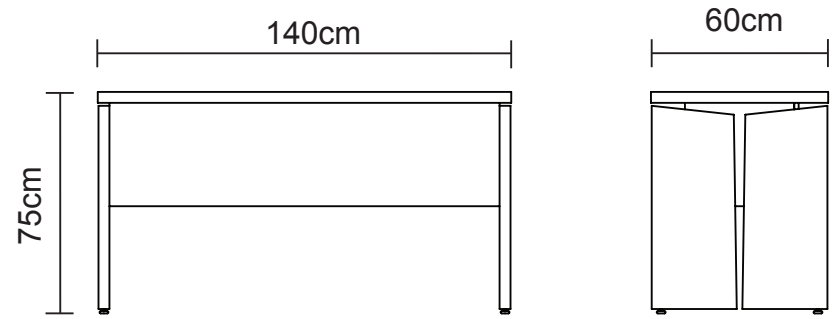

Conservação e Limpeza

Não expor o produto ao sol, altas temperaturas e umidade, mantendo-o em local seco e arejado.

Para a limpeza, utilizar um pano seco e macio. Não é necessário o uso de materiais abrasivos ou álcool.

Lista de Materiais

A	Cavilha	04
B	Minifix	02
C	Tambor	12
D	Minifix M6	10
E	Tapa Furo 22mm	28
F	Sapata regulável 1/4" Flex	04
G	Bucha sapata regulável 1/4" Flex	04

H1	Parafuso 4,0x45 CP	16
-----------	--------------------	-----------

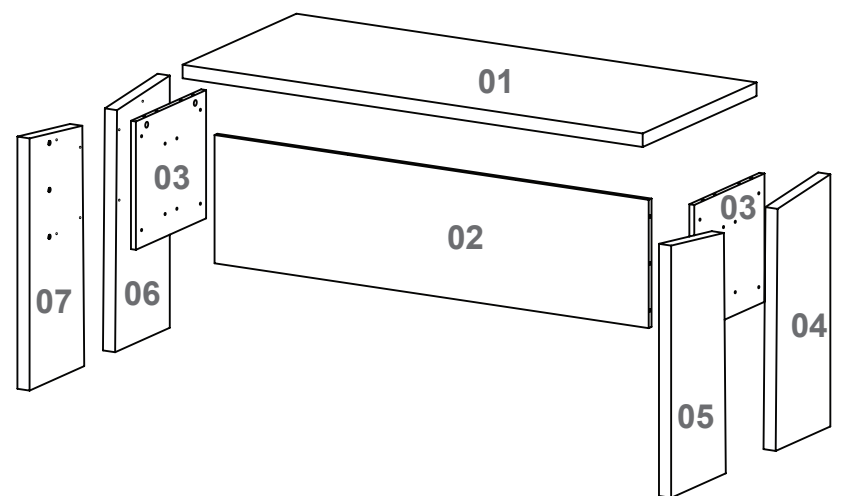

Denominação das Peças

- 01-Tampo
- 02-Travessa
- 03-Travessa Lateral
- 04-Lateral A
- 05-Lateral B
- 06-Lateral C
- 07-Lateral D

1º Passo - Ferragens em Tampo

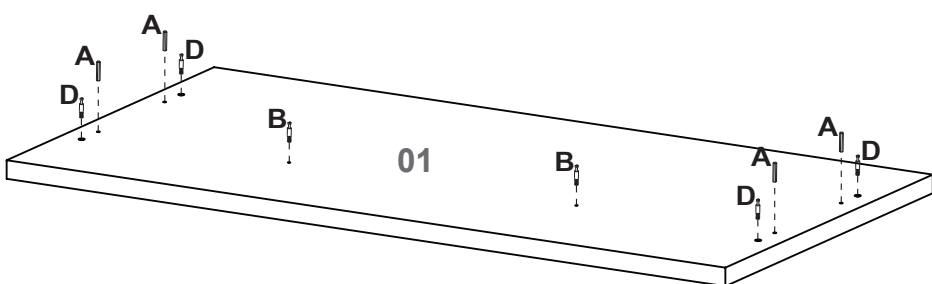

2º Passo - Montagem Laterais

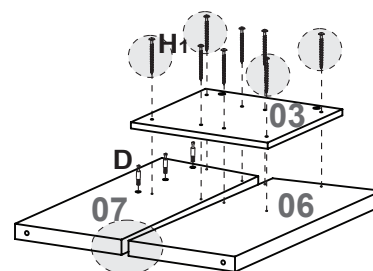

Detalhe dos pés
abertura de ± 20 mm

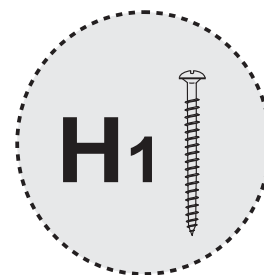

Recomenda-se
parafusar
primeiro os 4 parafusos
laterais, pré alinhando o
detalhe dos pés.

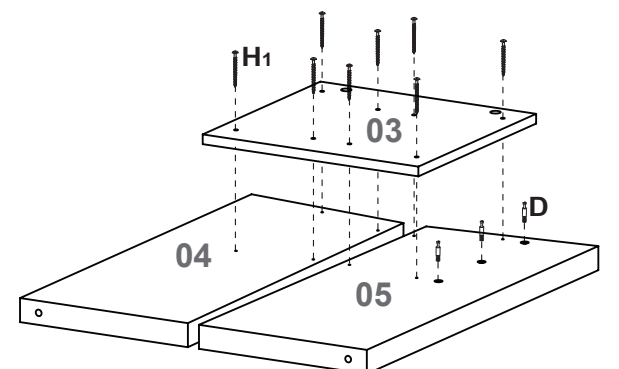

3º Passo - Montagem Laterais - Travessa

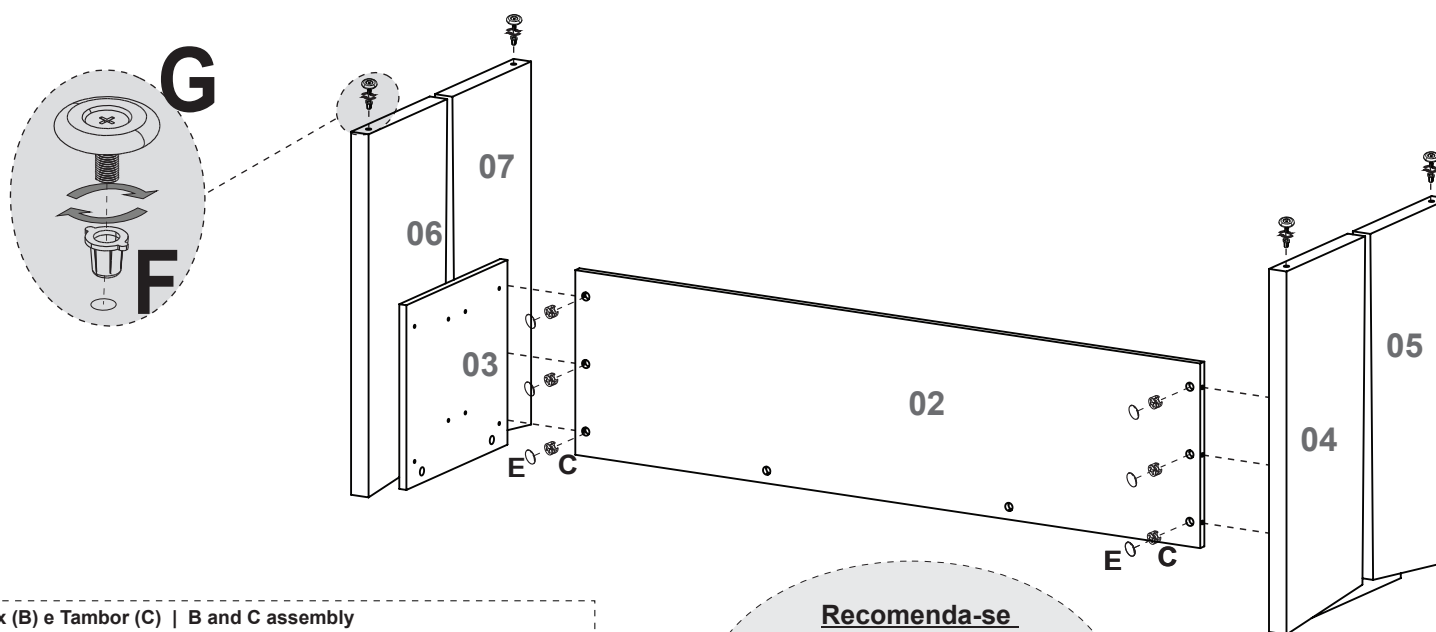

Fixação do Minifix (B) e Tambor (C) | B and C assembly

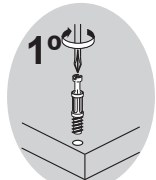

B-Minifix



C-Tambor



C-Tambor

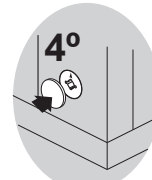

F-Tampa Tambor

Recomenda-se
Colocar primeiro o
Tambor (C) na
furação da peça (02) para
em seguida fixar nas peças
(05) e (07)

4º Passo - Montagem Tampo - Laterais - Travessa

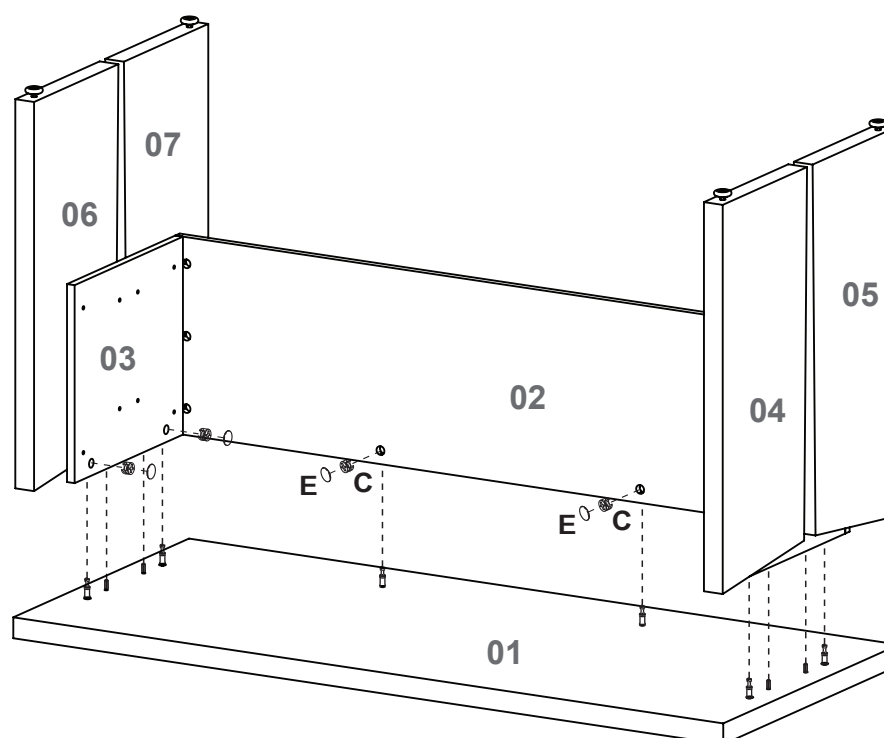

5º Passo - Acabamentos

