

MANUAL DE ARMADO

Manual del Producto
User's Guide

Rödler®

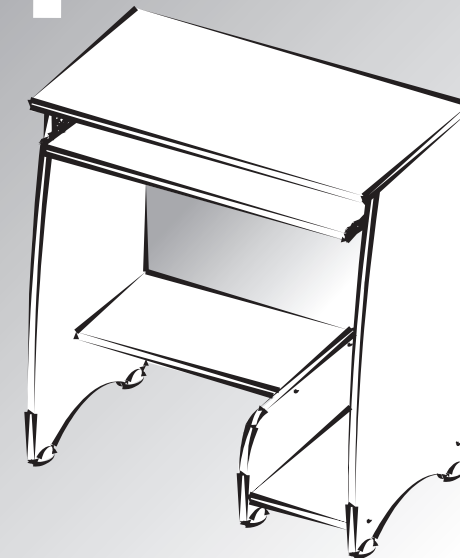

Rack para computador Pixel

Rack para Computadora Pixel / Pixel Computer Rack

Versão 1.0 / Versión 1.0 / Version 1.0

Rödler®

www.rodler.cl

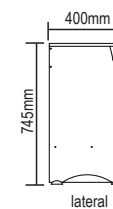
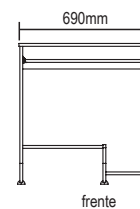

www.rodler.cl



Conservação e Limpeza

Conservación y Limpieza
Conservation and Cleanness

Não expor o produto ao sol, altas temperaturas e umidade, não arrastar objetos sobre a superfície do móvel (ex.: TV, DVD, aparelho de som, objetos decorativos...) e mantendo-o em local seco e arejado.

Para a limpeza, utilizar um pano seco e macio. Não é necessário o uso de materiais abrasivos ou álcool.

No exponga el producto a la luz solar, las altas temperaturas y la humedad, no arrastre los objetos a través de la superficie de la unidad (por ejemplo, TV, DVD, equipo de música, objetos de decoración ...) y mantenerlo en un lugar fresco y seco.







Para la limpieza, utilizar un paño seco y suave. El uso de materiales abrasivos o del alcohol no es necesario.

Do not expose the product to sunlight, high temperatures and humidity, do not drag objects across the surface of the unit (eg TV, DVD, stereo, decorative objects ...) and keeping it in a cool dry place.

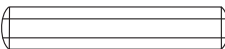
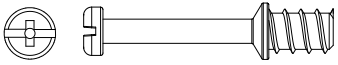
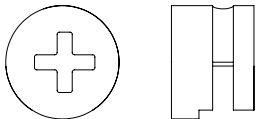
For cleaning, use a dry and soft cloth. Do not use abrasive materials or alcohol.

Lista de Materiais

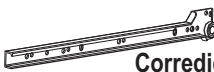
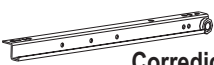
Lista de Materiales/ Hardware List

A		Cavilha	16
B		Minifix	4
C		Tambor	4
D		Tapa Furo Adesivo	4
E		Parafuso Ø3,5x40mm CP	12
F		Parafuso Ø3,5x12mm CC	8
G		Corrediça 300mm	2
H		Corrediça 300mm	2
I		Sapata Esférica	6
J		Cola	1

6

Passo
Passo
Step

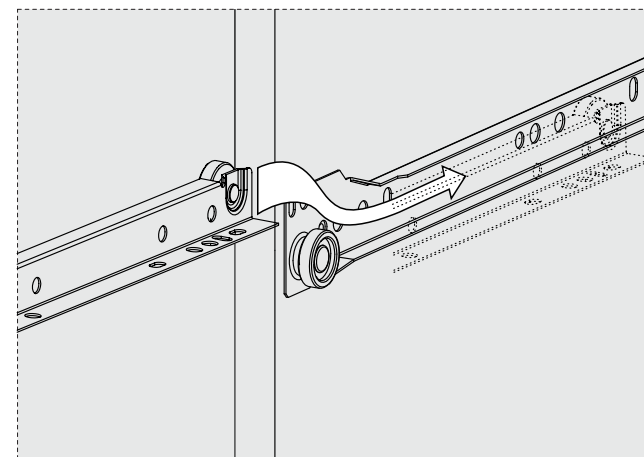

DETALHE DO
ENCAIXE DA CORREDIÇA

DETALLE DEL
ENCAJE DE LA CORREDIÇA

SLIDER FITTING
DETAIL



SIGA COM ATENÇÃO AS INSTRUÇÕES DE MONTAGEM.

SIGA CON ATENCIÓN LAS INSTRUCCIONES DE MONTAJE.

PROCEED WITH ATTENTION THE ASSEMBLING INSTRUCTIONS.

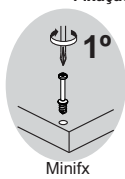

Minifix

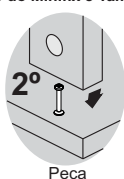

Peça

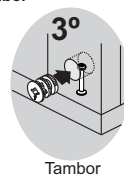

Tambor

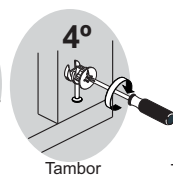

Tambor



Tapa Furo Adesivo

4 Passo
Passo
Step

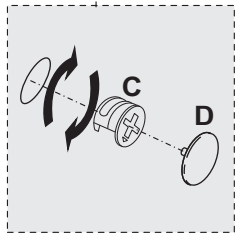
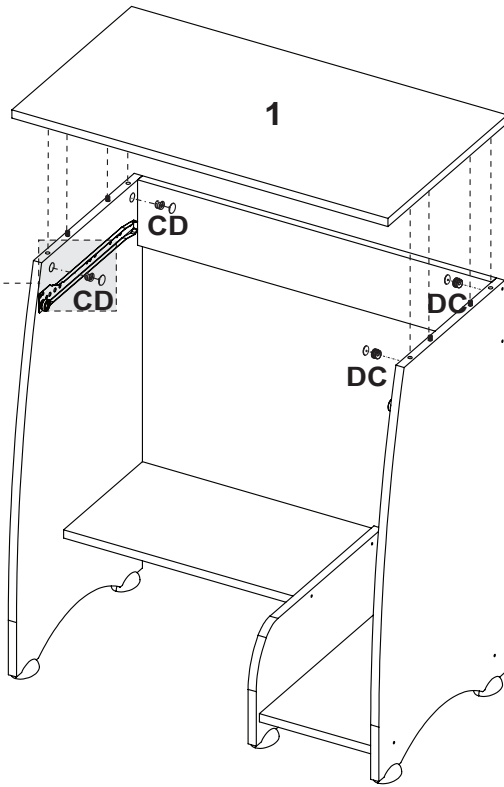

5 Passo
Passo
Step

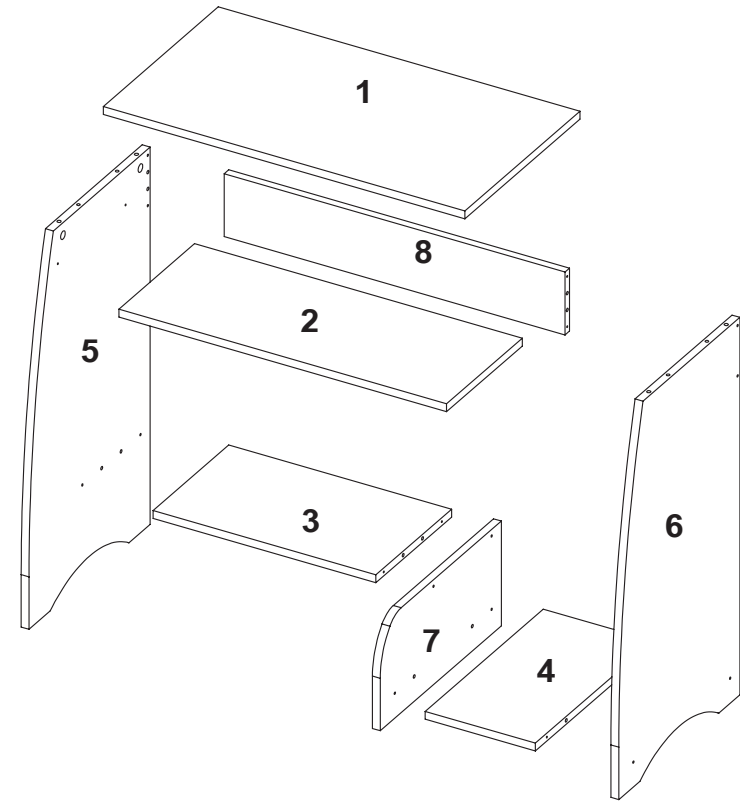
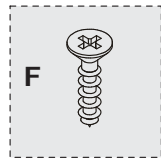
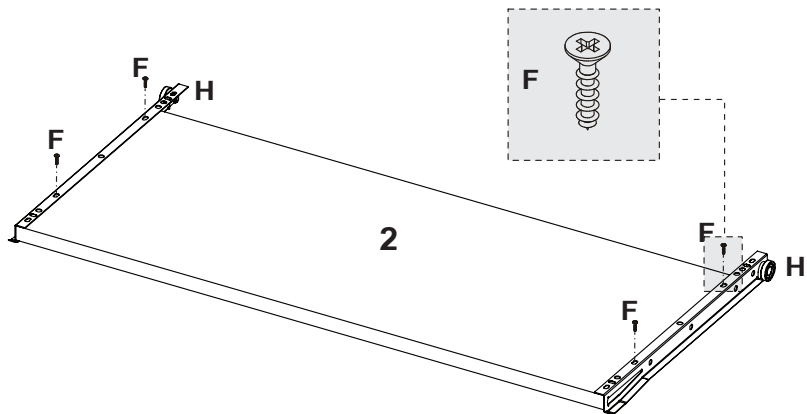

Denominação

- 1-Tampo (690x380x15mm)
- 2-Prateleira teclado (625x250x15mm)
- 3-Prateleira (425x250x15mm)
- 4-Base (210x390x15mm)
- 5-Lateral esquerda (720x400x15mm)
- 6-Lateral direita (720x400x15mm)
- 7-Divisão (200x400x15mm)
- 8-Travessa (650x120x15mm)

Denominación

- 1-Tapa
- 2-Anaquele teclado
- 3-Anaquele
- 4-Base
- 5-Lateral izquierda
- 6-Lateral derecha
- 7-División
- 8-Travesaño

Description

- 1-Top
- 2-Keyboard shelf
- 3-Shelf
- 4-Base
- 5-Left side
- 6-Right side
- 7-Partition
- 8-Crosspiece

1 Passo
Passo
Step

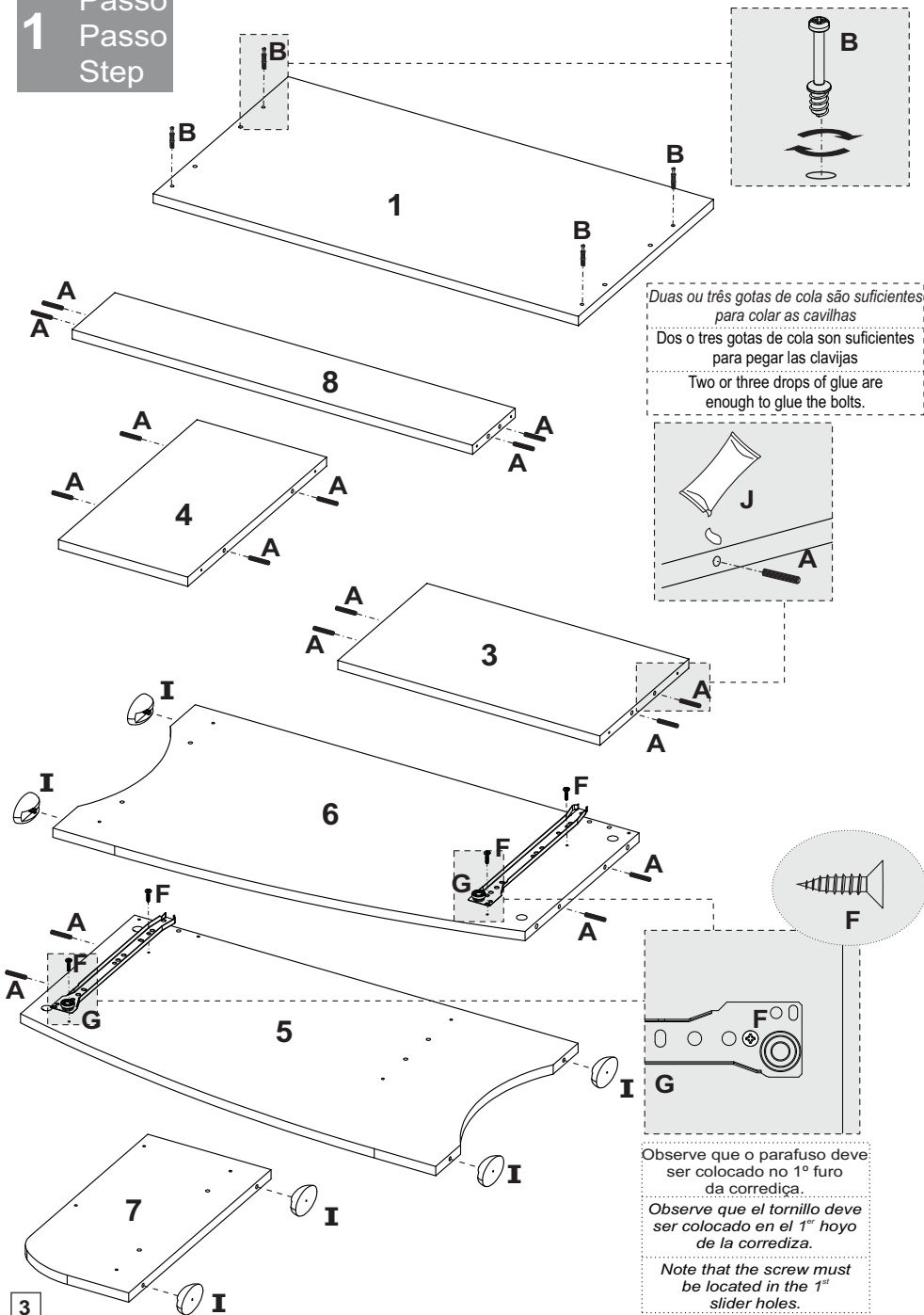

3

2 Passo
Passo
Step

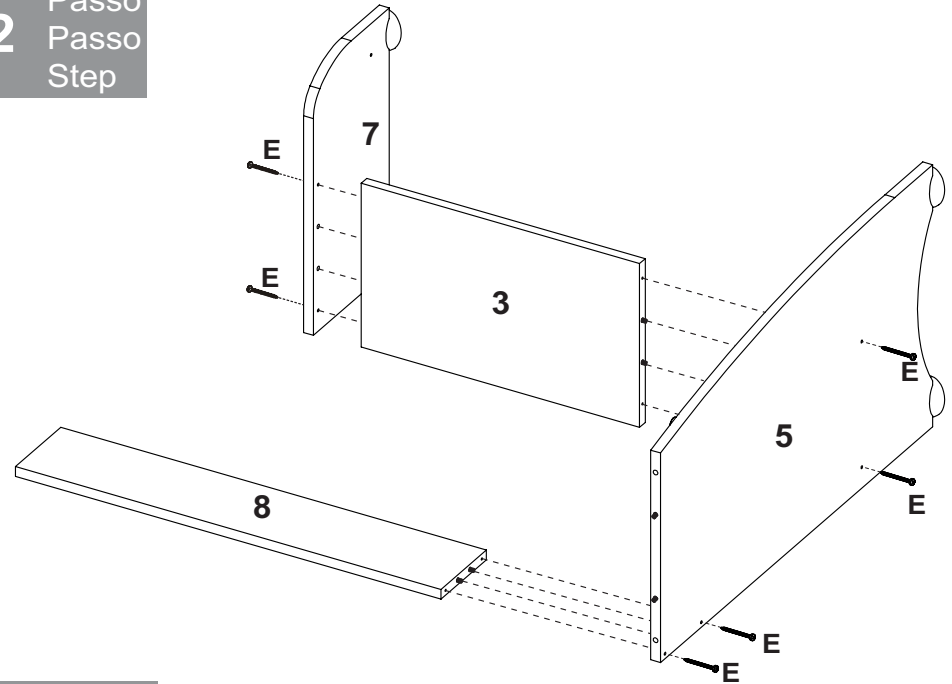

3 Passo
Passo
Step

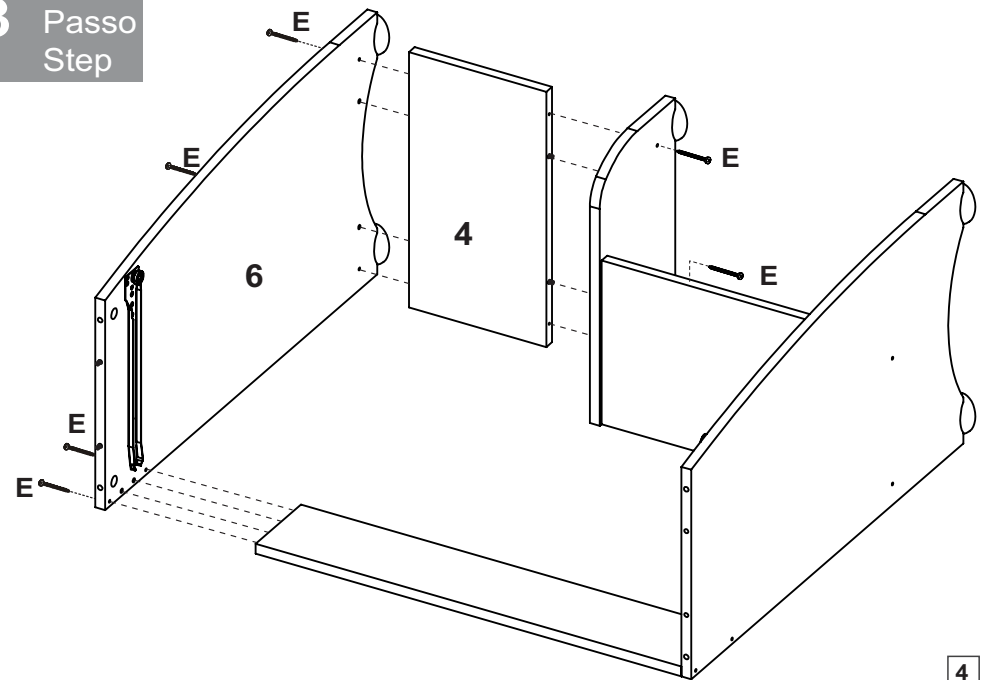

4