



**STILL THE BEST!**

DENVER, COLORADO

1-866-623-1963

[GENNIESHIFTER.COM](http://GENNIESHIFTER.COM)

[GENNIESHIFTER.COM](http://GENNIESHIFTER.COM)

INST100F3

1-877-7-GENNIE

**INSTRUCTIONS**  
**GENNIE**  
**SHIFTER™**

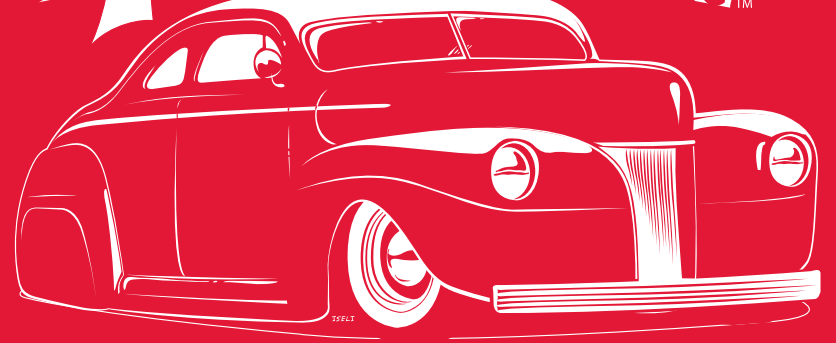

**FMX SHIFTER**

INST100F3

**BUTTON-LESS IS BETTER**

No Button

No Rattle

No Compromise

The *Original* and Still the best.

Shifters

Knobs

E-Brakes

Cables

Pedals

Boots

Dipsticks

Lights

Automatic Transmissions

Parts and Replacement Kits

[GENNIESHIFTER.COM](http://GENNIESHIFTER.COM)

1-877-7-GENNIE

# Installation and Adjustment

This unit has been pre-assembled, adjusted to initial specifications.  
Adjustments may be required for you particular application.

1. **Determine position** of 3-3/4" hole to be cut in floorboards by temporarily positioning shifter brackets on transmission.

**NOTE:** Some transmission brackets are formed from flat steel plates and may have multiple mounting positions.

2. **Drill test hole** in floorboards at selected position to obtain dead center of shifter. Use hole saw, snips, or drill bit to cut 3-3/4" hole in floorboards.

3. **Install** transmission brackets on transmission. Leave bolts at tailshaft housing slightly loose.

4. The shift mechanism is then lowered through the 3-3/4" hole in the floorboards and bolted to the shifter brackets using the two 5/16" - 2-1/4" bolts and tubular spacers provided. Center the shift mechanism on its slotted holes and tighten. **Take care not to over-tighten.** SEE PICTURE

5. Before installing the shift linkage, shift the stick between park position (near dash) and low (near seat) and determine if the stick position needs to be adjusted by using the slotted holes in the shift mechanism. If so, loosen the two 5/16" - 2-1/4" bolts and adjust stick position, then re-tighten. SEE PICTURE

6. Bolt trans arm to transmission (see picture).

7. With transmission in park, using care not to position the lever past the park detent, as this will definitely confuse the procedure. Adjust linkage so that the 10-32 bolts can be installed without moving either arm.

**NOTE: (Adjustment issues)** If you are having trouble engaging a gear, typically Park or Low, remove the splined arm on the shifter and re-position one spline in the direction needed. If the stick position has been adjusted all the way back (toward the seat) using the slotted holes in the shift mechanism, the splined arm on the shifter will definitely have to be adjusted 1 spline to the rear or the transmission will not go into 1st gear.

8. With bolts tight, shift through all positions to check synchronization of shifter stops and transmission detents. Adjust linkage slightly if necessary.

9. Adjust shifter friction (drag) by two 3/8" JAM NUTS on the cross shaft. (PROPER ADJUSTMENT REQUIRES A MODERATELY HEAVY AMOUNT OF DRAG TO AVOID SELF-SHIFTING.) SEE PICTURE

10. NOTE: If it becomes necessary to remove the stick from the mechanism for any reason, be sure to remove the spring #10 from the cross shaft before removing the roll pin #4 that holds the stick. The spring is behind the 3/8" set screw #11 that the jam nuts #12 are on. SEE PICTURE

11. If you desire a shorter stick, we stock several lengths including 12", 16", 23", 23" Swan, 23" Stainless Steel Swan and 28" sticks. Please call and order a retro fit kit.

## Copyright Warning:

All drawings and diagrams are property of and represent the intellectual assets of Gennie Shifter. Any use of copyrighted drawings or reproduction and/or reverse engineering of said property or assets will be subject to prosecution in a court of law. Hey, that's why it's the Original and still the best.

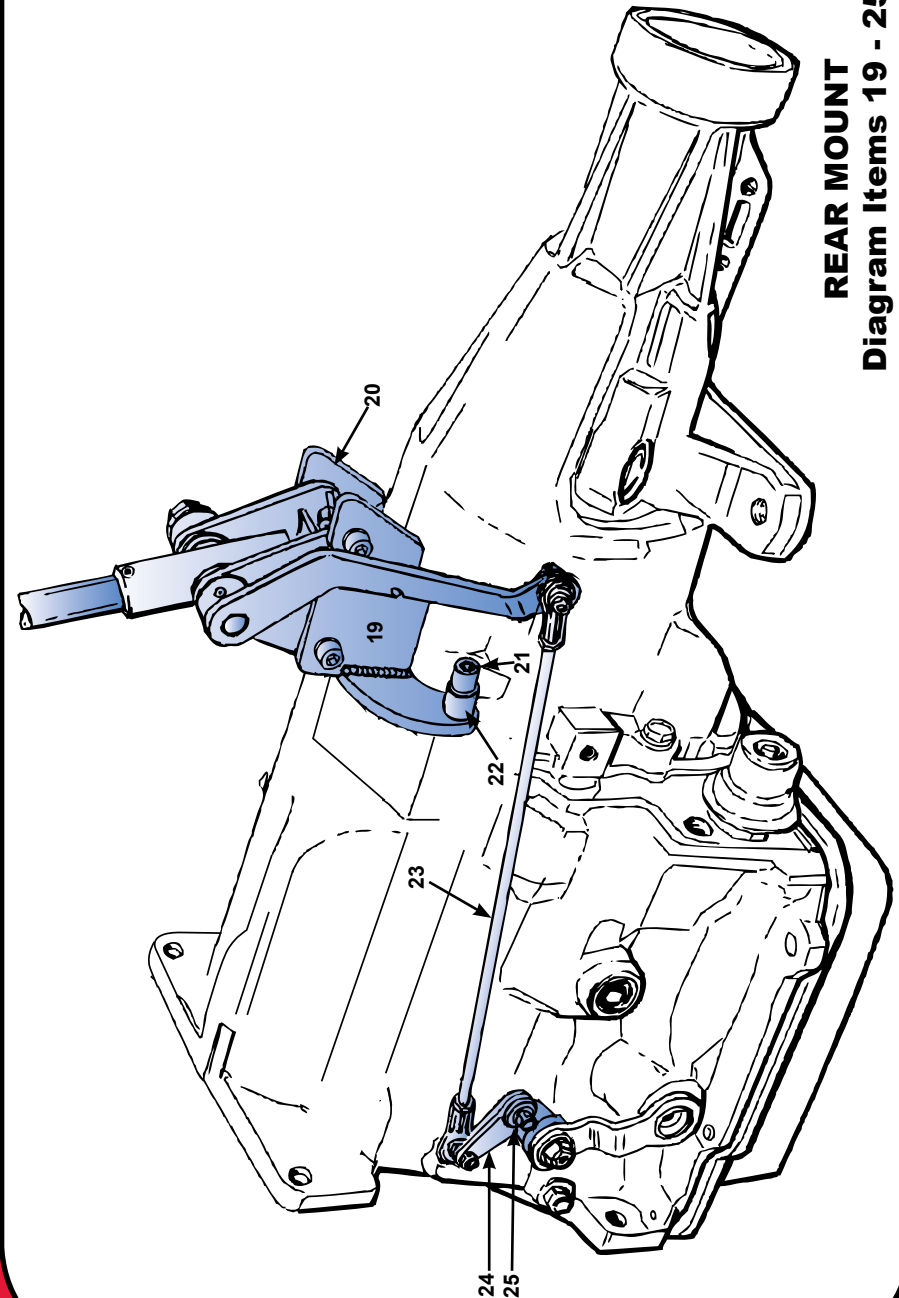

REAR MOUNT  
Diagram Items 19 - 25

COMPONENT LIST FOR REAR MOUNT FMX SHIFTER

Number on Diagram	Component	Description	Quantity
1	1015 to 1020	Shifter Stick	1
2	TBNG10001	T - Tube	1
3	RETA10001	Roll Pin Retainer	1
4	PINS30001	Pin - Roll 1/4 x 7/8	1
5	ARMS10002	Shift Arm RM	1
5	SCRW10012	10-24X5/16 Set Screw	1
6	BRKT20032	Triangle Bracket #1	1
7	BUSH10001	Delrin Bushing	3
8	BRKT20033	Triangle Bracket #2	1
9	WASHNFC6	1" OD x 7/16" ID x .075	1
10	SPRG	Internal Spring	1
11	SCRW10014	3/8-16 x 1" Sckt Set Screw	1
12	NUTS10037	NUT-JAM 3/8-16	2
13	WASH10011	Shim .568 x 1 x .048	1
13	WASH10030	.553x.837odx.016 Shim	1
13	WASHNFC5	WASHER #5 Shim 1" OD x 9/16" I	1
14	SWCH20001	Neutral Saftey Switch	1
15	SPAC10001	SHIFTER TUBE	2
16	PLAT10005	Plate - Selector C6 700 4L80	1
17	BOLT10011	5/16-18 x 2-1/2 Sckt Cap	2
18	JONT10001	Heim Joint	2
19	BRKT20022	Trans Bracket C6 RM LH	1
20	BRKT20023	Trans Bracket C6 RM RH	1
21	BOLT10031	3/8-16 x 1 3/4 Cap Soc	2
22	SPAC10007	1/2 Tube	2
23	RODS40007	Linkage Rod 8 1/4in	1
24	ARMS20003	Trans Arm FMX	1
25	SPAC10020	AOD Trans Arm Spacer	1
for 1	CAPS20001	Small Plastic Black Button Cap	1
for 1	KNOB	KNOB-3 SPEED	1
for 1	NUTS10018	Nut - Jam 5/16-18 SS	1
for 17	WASH10029	AN960 C516L Thin Washer SS	4
for 17	WASH10031	5/16 FLAT SS	2
for 17, 24	NUTS10033	Nut - Nylock 5/16-18	3
for 18	BOLT10026	10-32x3/4 Soc Cap	2
for 18	NUTS10009	Nut - Nylock 10-32	2
for 18	WASHNFC4	WASHER #4 AN 960 C10 Washer	2
for 23	NUTS10035	Nut - Jam 10-32 Plated	2
for 24	BOLT10013	5/16-18 x 1" Hex Head Plat G5	1
for 24	WASH10016	5/16 SAE Washer Plated	1

NEUTRAL SAFETY SWITCH

The GENNIE SHIFTER comes with a double pole normally open safety switch which is connected into the wire (series) from the IGN (ignition) switch to the POS (positive) side of the starter solenoid.

**WARNING:**  
*Proper operation of the neutral safety switch is extremely important so the vehicle does not start in gear. Due to variations in manufacturing, it may be required to shim the neutral safety switch, to allow for proper operation.*

UPPER SHIFTER  
 Diagram Items 1 - 18

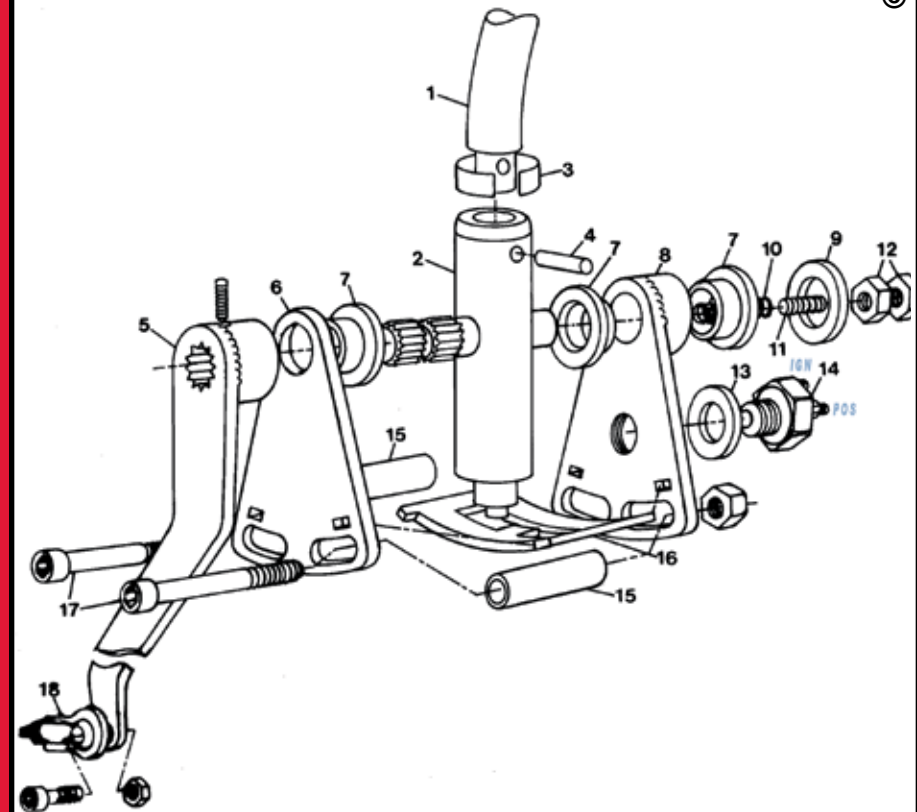

READ THIS NOTICE

This product will be partially or entirely replaced if defective in manufacture or packaging. Except for such replacement, the sale or any subsequent handling of this product is without warranty or liability even though defect, damage, or loss is caused by negligence or other fault. PLEASE CONSULT THE DEALER YOU PURCHASED THIS PRODUCT FROM.

COMPONENT LIST FOR MID-MOUNT FMX SHIFTER

Number on Diagram	Component	Description	Quantity
1	1015 to 1020	Shifter Stick	1
2	TBNG10001	T - Tube	1
3	RETA10001	Roll Pin Retainer	1
4	PINS30001	Pin - Roll 1/4 x 7/8	1
5	ARMS10001	Shift Arms	1
5	SCRW10012	10-24X5/16 Set Screw SHIFT ARM	1
6	BRKT20032	Triangle Bracket #1	1
7	BUSH10001	Delrin Bushing	3
8	BRKT20033	Triangle Bracket #2	1
9	WASHNFC6	1" OD x 7/16" ID x .075	1
10	SPRG	Internal Spring	1
11	SCRW10014	3/8-16 x 1" Sckt Set Screw	1
12	NUTS10037	NUT-JAM 3/8-16	2
13	WASH10011	Shim .568 x 1 x .048	1
13	WASH10030	.553x.837odx.016 Shim	1
13	WASHNFC5	WASHER #5 Shim 1" OD x 9/16" I	1
14	SWCH20001	Neutral Safety Switch	1
15	SPAC10001	SHIFTER TUBE	2
16	PLAT10005	Plate - Selector C6 700 4L80	1
17	BOLT10011	5/16-18 x 2-1/2 Sckt Cap	2
18	JONT10001	Heim Joint	2
19	BRKT20004	Trans Bracket C6 LH	1
20	BRKT20005	Trans Bracket C6 RH	1
21	BRKT10001	Shifter Bracket MTG	2
22	BOLT10004	3/8-16 X 1/2 Button Sckt Hd	4
23	SPAC10015	Spacer-5/8"	2
24	BOLT10023	3/8-16 x 1-1/2" Sckt Head Cap	2
25	ARMS20003	Trans Arm FMX	1
26	SPAC10020	AOD Trans Arm Spacer	1
27	RODS40002	Linkage Rod 3in	1
27	RODS40003	Linkage Rod 3 7/8in	1
27	RODS40006	Linkage Rod 6 5/8in	1
for 1	CAPS20001	Small Plastic Black Button Cap	1
for 1	KNOB	KNOB-3 SPEED	1
for 1	NUTS10018	Nut - Jam 5/16-18 SS	1
for 17	WASH10031	5/16 FLAT SS	2
for 17, 25	NUTS10033	Nut - Nylock 5/16-18	3
for 18	BOLT10026	10-32x3/4 Soc Cap	2
for 18	NUTS10009	Nut - Nylock 10-32	2
for 18	WASHNFC4	WASHER #4 AN 960 C10 Washer	2
for 22	WASHNFC3	WASHER #3 3/8 AN 960 C616L	4
for 25	BOLT10013	5/16-18 x 1" Hex Head Plat G5	1
for 25	WASH10016	5/16 SAE Washer Plated	1
for 27	NUTS10035	Nut - Jam 10-32 Plated	2

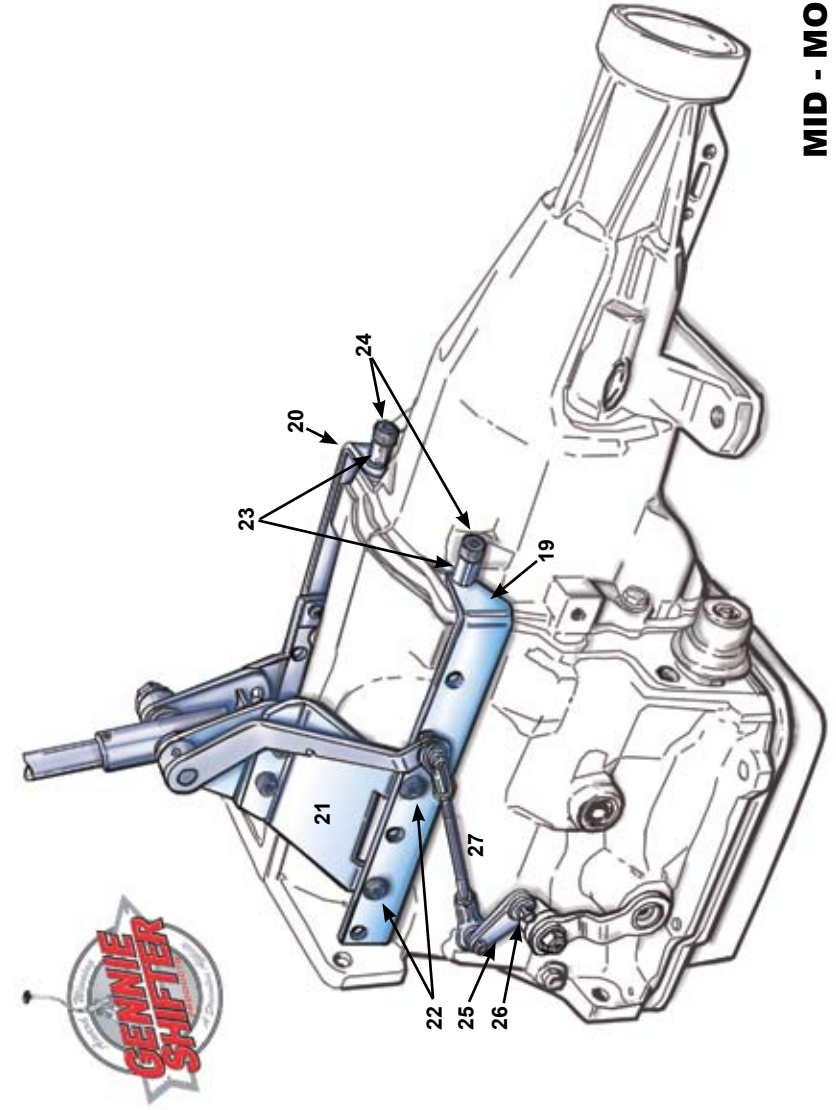

MID - MOUNT  
Diagram Items 19 - 27