



STILL THE BEST!

DENVER, COLORADO

1-866-623-1963

GENNIESHIFTER.COM

GENNIESHIFTER.COM

INST100M1

1-877-7-GENNIE

INSTRUCTIONS
GENNIE
SHIFTER™

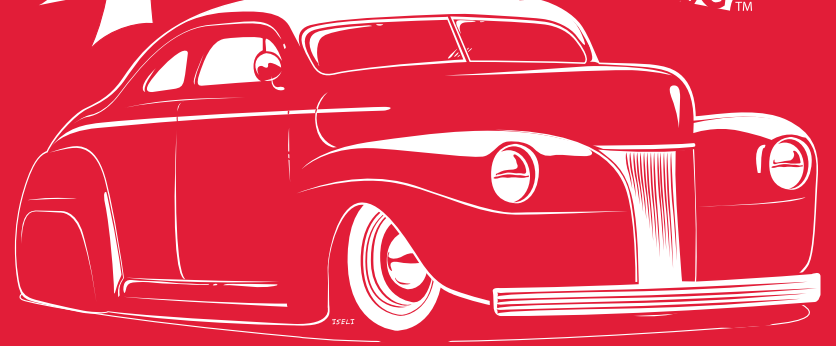

727 SHIFTER

INST100M1

BUTTON-LESS IS BETTER

The *Original* and Still the best.

Shifters Knobs E-Brakes Cables

Pedals Boots Dipsticks Lights

Automatic Transmissions

Parts and Replacement Kits

GENNIESHIFTER.COM

1-877-7-GENNIE

Installation and Adjustment

This unit has been pre-assembled, adjusted to initial specifications.
Adjustments may be required for you particular application.

1. **Determine position** of 3-3/4" hole to be cut in floorboards by temporarily positioning shifter brackets on transmission.

NOTE: Some transmission brackets are formed from flat steel plates and may have multiple mounting positions.

2. **Drill test hole** in floorboards at selected position to obtain dead center of shifter. Use hole saw, snips, or drill bit to cut 3-3/4" hole in floorboards.

3. **Install** transmission brackets on transmission. Leave bolts at tailshaft housing slightly loose.

NOTE: (Optional) On mid-mount, rubber pads may be placed between saddle mount brackets and transmission to minimize any potential vibration.

4. The shift mechanism is then lowered through the 3-3/4" hole in the floorboards and bolted to the shifter brackets using the two 5/16" - 2-1/4" bolts and tubular spacers provided. Center the shift mechanism on its slotted holes and tighten. **Take care not to over-tighten.** SEE PICTURE

5. Before installing the shift linkage, shift the stick between park position (near dash) and low (near seat) and determine if the stick position needs to be adjusted by using the slotted holes in the shift mechanism. If so, loosen the two 5/16" - 2-1/4" bolts and adjust stick position, then re-tighten. SEE PICTURE

6. With transmission in park, using care not to position the lever past the park detent, as this will definitely confuse the procedure. Adjust linkage so that the 1/4" bolts can be installed without moving either arm.

NOTE: (Adjustment issues) If you are having trouble engaging a gear, typically Park or Low, remove the splined arm on the shifter and re-position one spline in the direction needed. If the stick position has been adjusted all the way back (toward the seat) using the slotted holes in the shift mechanism, the splined arm on the shifter will definitely have to be adjusted 1 spline to the rear or the transmission will not go into 1st gear.

7. With bolts tight, shift through all positions to check synchronization of shifter stops and transmission detents. Adjust linkage slightly if necessary.

8. Adjust shifter friction (drag) by two 3/8" JAM NUTS on the cross shaft. (PROPER ADJUSTMENT REQUIRES A MODERATELY HEAVY AMOUNT OF DRAG TO AVOID SELF-SHIFTING.) SEE PICTURE

9. **NOTE:** If it becomes necessary to remove the stick from the mechanism for any reason, be sure to remove the spring #10 from the cross shaft before removing the roll pin #4 that holds the stick. The spring is behind the 3/8" set screw #11 that the jam nuts #12 are on. SEE PICTURE

10. If you desire a shorter stick, we stock several lengths including 12", 16", 23", 23" Swan, 23" Stainless Steel Swan and 28" sticks. Please call and order a retro fit kit.

Copyright Warning:

All drawings and diagrams are property of and represent the intellectual assets of Gennie Shifter. Any use of copyrighted drawings or reproduction and/or reverse engineering of said property or assets will be subject to prosecution in a court of law. Hey, that's why it's the Original and still the best.

©

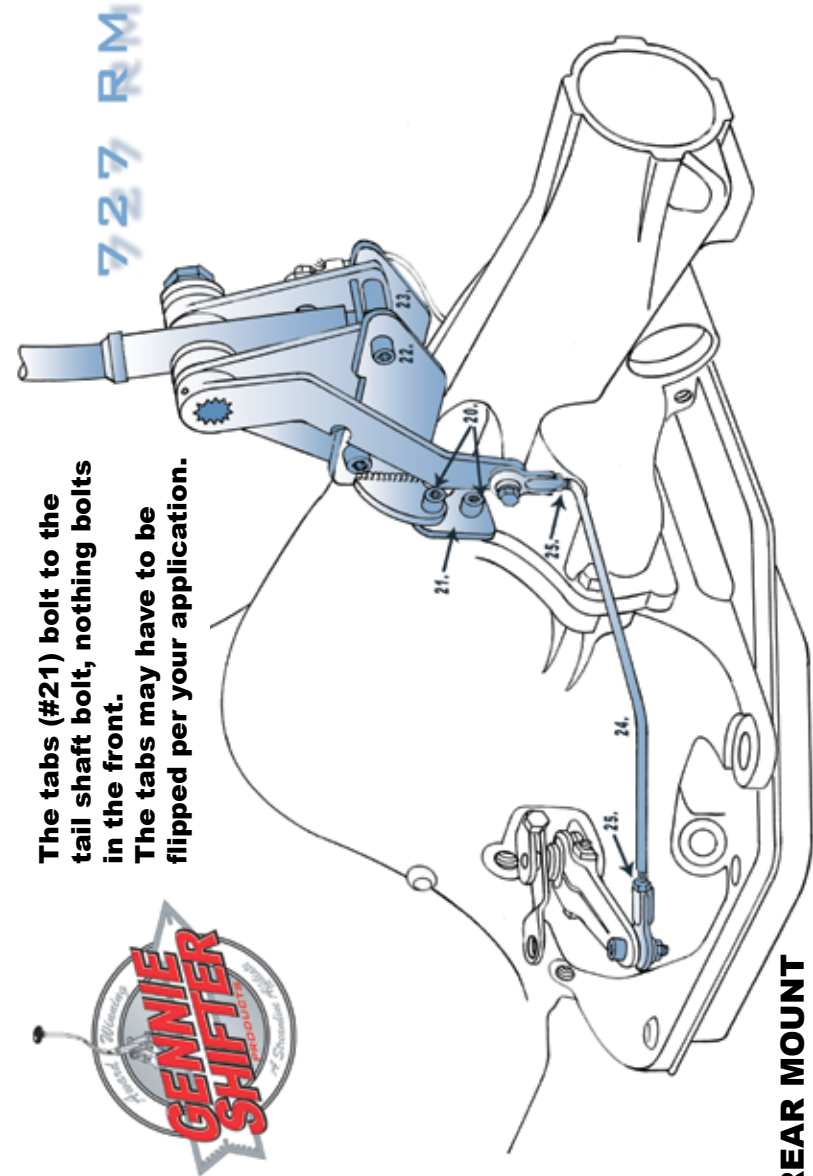

REAR MOUNT
Diagram Items 20 - 25

COMPONENT LIST FOR REAR MOUNT MOPAR 727 SHIFTER

Number on Diagram	Component	Description	Quantity
1	1015 to 1020	Shifter Stick	1
2	TBNG10001	T - Tube	1
3	RETA10001	Roll Pin Retainer	1
4	PINS30001	Pin - Roll 1/4 x 7/8	1
5	ARMS10001	Shift Arms	1
6	BRKT20032	Triangle Bracket #1	1
7	BUSH10001	Delrin Bushing	3
8	BRKT20033	Triangle Bracket #2	1
9	WASHNFC6	1" OD x 7/16" ID x .075 (USS 3	1
10	SPRG	Internal Spring	1
11	SCRW10014	3/8-16 x 1" Sckt Set Screw	1
12	NUTS10037	NUT-JAM 3/8-16	2
13	WASH10011	Shim .568 x 1 x .048	1
13	WASH10030	.553x.837odx.016 Shim	1
13	WASHNFC5	WASHER #5 Shim 1" OD x 9/16" I	1
14	SWCH20001	Neutral Saftey Switch	1
15	SPAC10001	SHIFTER TUBE	2
16	PLAT10008	Plate - Mopar	1
17	BOLT10011	5/16-18 x 2-1/2 Sckt Cap	2
18	JONT10002	Fat Hliem Joint	2
20	BOLT10035	3/8-16 x 1 Soc Head	4
21	TABS20003	Mopar Cheater Tab	2
22	BRKT20024	Trans Bracket C4 LH RM	1
23	BRKT20025	Trans Bracket C4 RH RM	1
24	RODS10008	Mopar Link Rod	1
25	NUTS10006	Nut - Jam 1/4 x 28	2
for 1.	CAPS20001	Small Plastic Black Button Cap	1
for 1.	KNOB	KNOB-3 SPEED	1
for 1.	NUTS10018	Nut - Jam 5/16-18 SS	1
for 17.	NUTS10033	Nut - Nylock 5/16-18	2
for 17.	WASH10029	AN960 C516L Thin Washer SS	4
for 18.	BOLT10027	1/4-28x7/8 Soc Cap	2
for 18.	NUTS10034	Nut - Jam 1/4-28 NI	2
for 20.	NUTS10036	Nut - Nylock 3/8 - 16	2
for 20.	WASHNFC3	WASHER #3 3/8 AN 960 C616L	2
for 5.	SCRW10012	10-24X5/16 Set Screw SHIFT ARM	1

NEUTRAL SAFETY SWITCH

The GENNIE SHIFTER comes with a double pole normally open safety switch which is connected into the wire (series) from the IGN (ignition) switch to the POS (positive) side of the starter solenoid.

WARNING:
Proper operation of the neutral safety switch is extremely important so the vehicle does not start in gear. Due to variations in manufacturing, it may be required to shim the neutral safety switch, to allow for proper operation.

UPPER SHIFTER
 Diagram Items 1 - 18

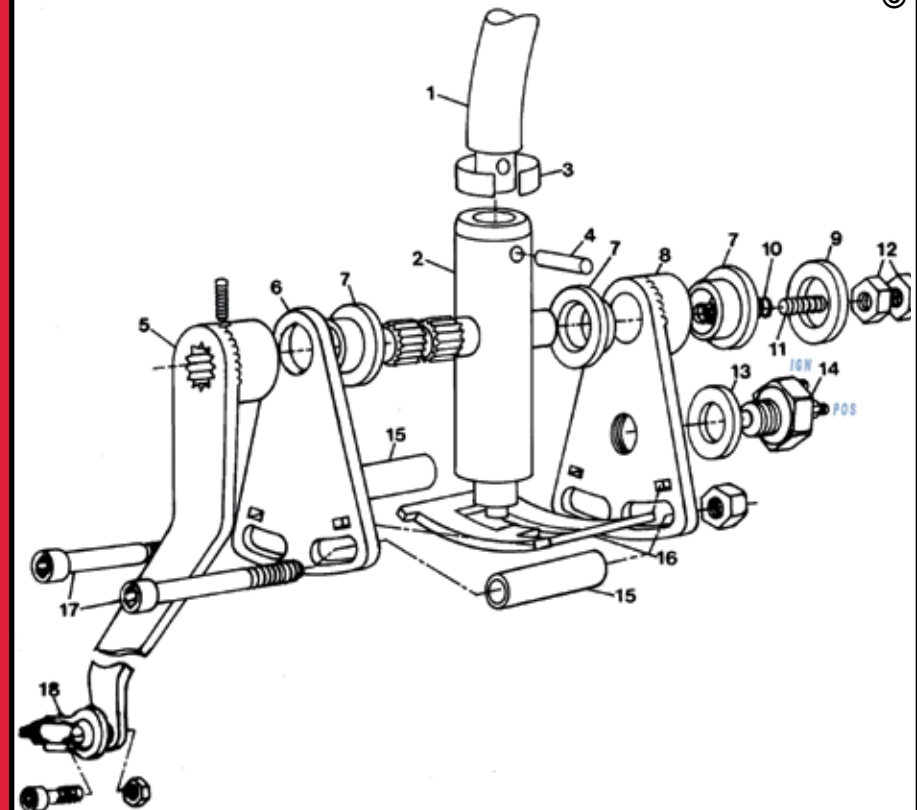

READ THIS NOTICE

This product will be partially or entirely replaced if defective in manufacture or packaging. Except for such replacement, the sale or any subsequent handling of this product is without warranty or liability even though defect, damage, or loss is caused by negligence or other fault. PLEASE CONSULT THE DEALER YOU PURCHASED THIS PRODUCT FROM.

COMPONENT LIST FOR MID-MOUNT MOPAR 727 SHIFTER

Number on Diagram	Component	Description	Quantity
1	1015 to 1020	Shifter Stick	1
2	TBNG10001	T - Tube	1
3	RETA10001	Roll Pin Retainer	1
4	PINS30001	Pin - Roll 1/4 x 7/8	1
5	ARMS10001	Shift Arms	1
6	BRKT20032	Triangle Bracket #1	1
7	BUSH10001	Delrin Bushing	3
8	BRKT20033	Triangle Bracket #2	1
9	WASHNFC6	1" OD x 7/16" ID x .075 (USS 3	1
10	SPRG	Internal Spring	1
11	SCRW10014	3/8-16 x 1" Sckt Set Screw	1
12	NUTS10037	NUT-JAM 3/8-16	2
13	WASH10011	Shim .568 x 1 x .048	1
13	WASH10030	.553x.837odx.016 Shim	1
13	WASHNFC5	WASHER #5 Shim 1" OD x 9/16" I	1
14	SWCH20001	Neutral Saftey Switch	1
15	SPAC10001	SHIFTER TUBE	2
16	PLAT10008	Plate - Mopar	1
17	BOLT10011	5/16-18 x 2-1/2 Sckt Cap	2
18	JONT10002	Fat Hiem Joint	2
20	BOLT10035	3/8-16 x 1 Soc Head	4
21	TABS20003	Mopar Cheater Tab	2
22	BRKT20006	Trans Bracket PG LH	1
23	BRKT20007	Trans Bracket PG RH	1
24	RODS10001	Link Rod Mopar RM	1
25	NUTS10006	Nut - Jam 1/4 x 28	2
26	BRKT10001	Shifter Bracket MTG	2
27	BOLT10004	3/8-16 X 1/2 Button Sckt Hd	4
for 1.	CAPS20001	Small Plastic Black Button Cap	1
for 1.	KNOB	KNOB-3 SPEED	1
for 1.	NUTS10018	Nut - Jam 5/16-18 SS	1
for 17.	NUTS10033	Nut - Nylock 5/16-18	2
for 17.	WASH10029	AN960 C516L Thin Washer SS	4
for 18.	BOLT10027	1/4-28x7/8 Soc Cap	2
for 18.	NUTS10034	Nut - Jam 1/4-28 NI	2
for 18.	WASH10033	1/4 AN Thin	2
for 20.	NUTS10036	Nut - Nylock 3/8 - 16	2
for 5.	SCRW10012	10-24X5/16 Set Screw SHIFT ARM	1

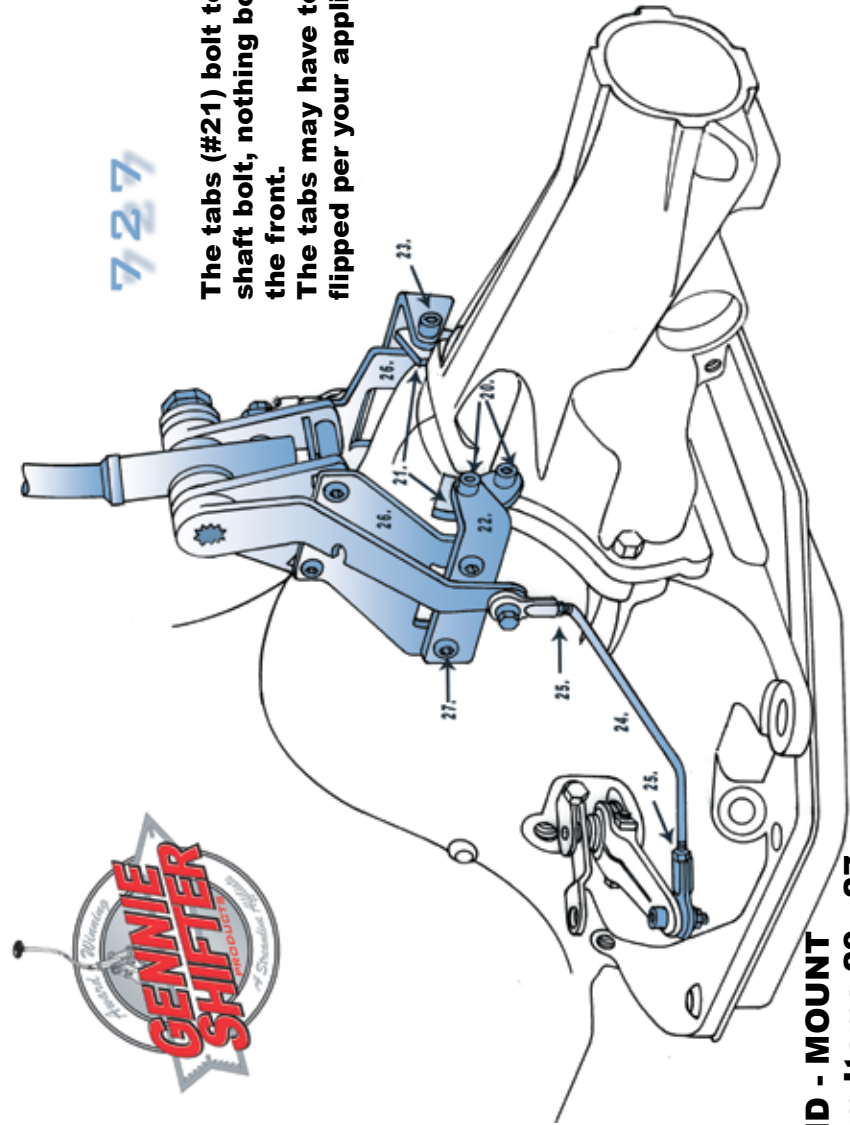

**The tabs (#21) bolt to the tail shaft bolt, nothing bolts in the front.
The tabs may have to be flipped per your application.**

**MID - MOUNT
Diagram Items 20 - 27**