



STILL THE BEST!

DENVER, COLORADO

1-866-623-1963

GENNIESHIFTER.COM

GENNIESHIFTER.COM

INST100G3

1-877-7-GENNIE

INSTRUCTIONS
GENNIE
SHIFTER™

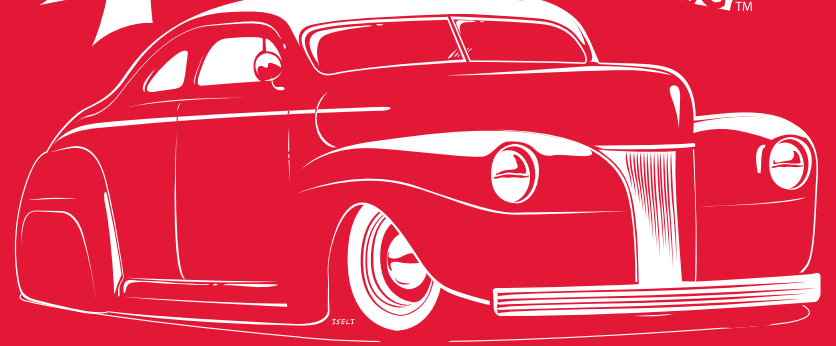

4L-60 SHIFTER

INST100G3

BUTTON-LESS IS BETTER

No Button

No Rattle

No Compromise

The *Original* and Still the best.

Shifters

Knobs

E-Brakes

Cables

Pedals

Boots

Dipsticks

Lights

Automatic Transmissions

Parts and Replacement Kits

GENNIESHIFTER.COM

1-877-7-GENNIE

Installation and Adjustment

This unit has been pre-assembled, adjusted to initial specifications.
Adjustments may be required for you particular application.

1. **Determine position** of 3-3/4" hole to be cut in floorboards by temporarily positioning shifter brackets on transmission.

NOTE: Some transmission brackets are formed from flat steel plates and may have multiple mounting positions.

2. **Drill test hole** in floorboards at selected position to obtain dead center of shifter. Use hole saw, snips, or drill bit to cut 3-3/4" hole in floorboards.

3. **Install** transmission brackets on transmission. Leave bolts at tailshaft housing slightly loose.

NOTE: (Optional) On mid-mount, rubber pads may be placed between saddle mount brackets and transmission to minimize any potential vibration.

4. The shift mechanism is then lowered through the 3-3/4" hole in the floorboards and bolted to the shifter brackets using the two 5/16" - 2-1/4" bolts and tubular spacers provided. Center the shift mechanism on its slotted holes and tighten. **Take care not to over-tighten.** SEE PICTURE

5. Before installing the shift linkage, shift the stick between park position (near dash) and low (near seat) and determine if the stick position needs to be adjusted by using the slotted holes in the shift mechanism. If so, loosen the two 5/16" - 2-1/4" bolts and adjust stick position, then re-tighten. SEE PICTURE

6. Install trans arm (see photos). On 4L-60 transmissions install arm with curve toward transmission. Use new split lock washer.

7. With transmission in park, using care not to position the lever past the park detent, as this will definitely confuse the procedure. Adjust linkage so that the 10-32 bolts can be installed without moving either arm.

NOTE: (Adjustment issues) If you are having trouble engaging a gear, typically Park or Low, remove the splined arm on the shifter and re-position one spline in the direction needed. If the stick position has been adjusted all the way back (toward the seat) using the slotted holes in the shift mechanism, the splined arm on the shifter will definitely have to be adjusted 1 spline to the rear or the transmission will not go into 1st gear.

8. With bolts tight, shift through all positions to check synchronization of shifter stops and transmission detents. Adjust linkage slightly if necessary.

9. Adjust shifter friction (drag) by two 3/8" JAM NUTS on the cross shaft. (PROPER ADJUSTMENT REQUIRES A MODERATELY HEAVY AMOUNT OF DRAG TO AVOID SELF-SHIFTING.) SEE PICTURE

10. **NOTE:** If it becomes necessary to remove the stick from the mechanism for any reason, be sure to remove the spring #10 from the cross shaft before removing the roll pin #4 that holds the stick. The spring is behind the 3/8" set screw #11 that the jam nuts #12 are on. SEE PICTURE

11. If you desire a shorter stick, we stock several lengths including 12", 16", 23", 23" Swan, 23" Stainless Steel Swan and 28" sticks. Please call and order a retro fit kit.

Copyright Warning:

All drawings and diagrams are property of and represent the intellectual assets of Gennie Shifter. Any use of copyrighted drawings or reproduction and/or reverse engineering of said property or assets will be subject to prosecution in a court of law. Hey, that's why it's the Original and still the best.

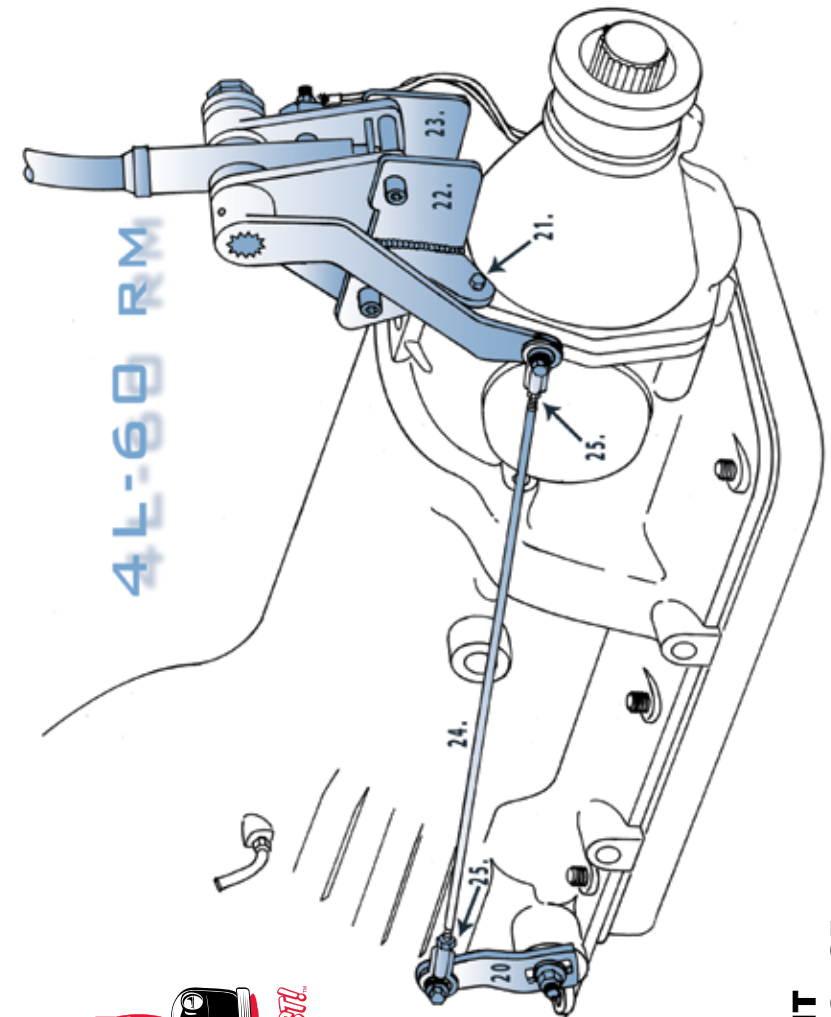

COMPONENT LIST FOR REAR MOUNT 4L-60 SHIFTER

Number on Diagram	Component	Description	Quantity
1	1015 to 1020	Shifter Stick	1
5	ARMS10002	Shift Arm RM	1
2	TBNG10001	T - Tube	1
3	RETA10001	Roll Pin Retainer	1
4	PINS30001	Pin - Roll 1/4 x 7/8	1
5	SCRW10012	10-24X5/16 Set Screw SHIFT ARM	1
6	BRKT20032	Triangle Bracket #1	1
7	BUSH10001	Delrin Bushing	3
8	BRKT20033	Triangle Bracket #2	1
9	WASHNFC2	WASHER #2 1" OD x 13/32 ID x .	1
10	SPRG	Internal Spring	1
11	SCRW10014	3/8-16 x 1" Sckt Set Screw	1
12	NUTS10037	NUT-JAM 3/8-16	2
13	WASH10011	Shim .568 x 1 x .048	1
13	WASH10030	.553x.837odx.016 Shim	1
13	WASHNFC5	WASHER #5 Shim 1" OD x 9/16" I	1
14	SWCH20001	Neutral Saftey Switch	1
15	SPAC10001	SHIFTER TUBE	2
16	PLAT10002	Plate - Selector 350 RM	1
17	BOLT10011	5/16-18 x 2-1/2 Sckt Cap	2
18	JONT10001	Heim Joint	2
20	ARMS20006	Trans Arm 350 RM	1
21	BOLT10035	3/8-16 x 1 Soc Head	2
22	BRKT20026	Trans Bracket 350 RM LH	1
23	BRKT20027	Trans Bracket 350 RM RH	1
24	RODS10003	Linkage Rod 350-400 RM	1
25	NUTS10035	Nut - Jam 10-32 Plated	2
for 1.	CAPS20001	Small Plastic Black Button Cap	1
for 1.	KNOB	KNOB-3 SPEED	1
for 1.	NUTS10018	Nut - Jam 5/16-18 SS	1
for 17.	NUTS10033	Nut - Nylock 5/16-18	2
for 17.	WASH10029	AN960 C516L Thin Washer SS	4
for 18.	BOLT10026	10-32x3/4 Soc Cap	2
for 18.	NUTS10009	Nut - Nylock 10-32	2
for 18.	WASHNFC4	WASHER #4 AN 960 C10 Washer	2
for 21.	SPAC10007	1/2 Tube	2

NEUTRAL SAFETY SWITCH

The GENNIE SHIFTER comes with a double pole normally open safety switch which is connected into the wire (series) from the **IGN** (ignition) switch to the **POS** (positive) side of the starter solenoid.

WARNING:
Proper operation of the neutral safety switch is extremely important so the vehicle does not start in gear. Due to variations in manufacturing, it may be required to shim the neutral safety switch, to allow for proper operation.

UPPER SHIFTER
Diagram Items 1 - 18

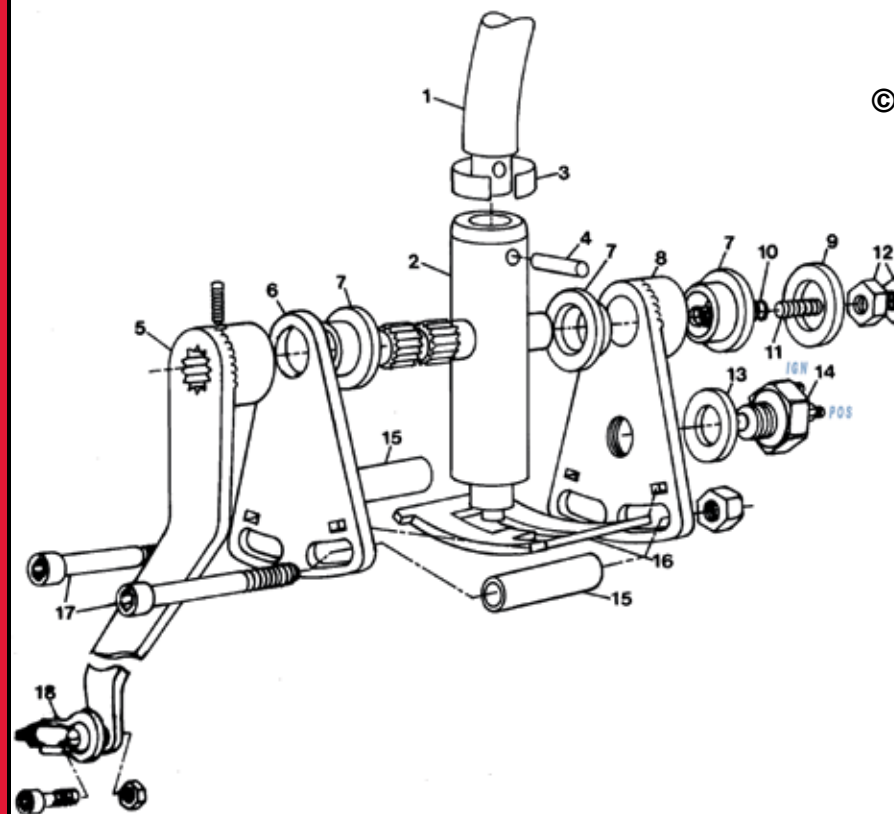

READ THIS NOTICE

This product will be partially or entirely replaced if defective in manufacture or packaging. Except for such replacement, the sale or any subsequent handling of this product is without warranty or liability even though defect, damage, or loss is caused by negligence or other fault. PLEASE CONSULT THE DEALER YOU PURCHASED THIS PRODUCT FROM.

COMPONENT LIST FOR MID-MOUNT 4L-60 SHIFTER

Number on Diagram	Component	Description	Quantity
1	1015 to 1020	Shifter Stick	1
2	TBNG10001	T - Tube	1
3	RETA10001	Roll Pin Retainer	1
4	PINS30001	Pin - Roll 1/4 x 7/8	1
5	ARMS10001	Shift Arms	1
5	SCRW10012	10-24X5/16 Set Screw SHIFT ARM	1
6	BRKT20032	Triangle Bracket #1	1
7	BUSH10001	Delrin Bushing	3
8	BRKT20033	Triangle Bracket #2	1
9	WASHNFC2	WASHER #2 1" OD x 13/32 ID x .	1
10	SPRG	Internal Spring	1
11	SCRW10014	3/8-16 x 1" Sckt Set Screw	1
12	NUTS10037	NUT-JAM 3/8-16	2
13	WASH10011	Shim .568 x 1 x .048	1
13	WASH10030	.553x.837odx.016 Shim	1
13	WASHNFC5	WASHER #5 Shim 1" OD x 9/16" I	1
14	SWCH20001	Neutral Saftey Switch	1
15	SPAC10001	SHIFTER TUBE	2
16	PLAT10001	Plate - Selector 350-400	1
17	BOLT10011	5/16-18 x 2-1/2 Sckt Cap	2
18	JONT10001	Heim Joint	2
20	ARMS20007	Trans Arm 350	1
21	STUD20001	Trans Bracket Stud	2
22	BRKT20002	Trans Brkt 400/ 700 2 Hole RH	1
23	BRKT20003	Trans Bracket 400/700 LH	1
24	RODS40005	Linkage Rod 5 1/2in	1
25	NUTS10035	Nut - Jam 10-32 Plated	2
for 1.	CAPS20001	Small Plastic Black Button Cap	1
for 1.	KNOB	KNOB-3 SPEED	1
for 1.	NUTS10018	Nut - Jam 5/16-18 SS	1
for 17.	NUTS10033	Nut - Nylock 5/16-18	2
for 17.	WASH10029	AN960 C516L Thin Washer SS	4
for 18.	BOLT10026	10-32x3/4 Soc Cap	2
for 18.	NUTS10009	Nut - Nylock 10-32	2
for 18.	WASHNFC4	WASHER #4 AN 960 C10 Washer	2
for 21.	NUTS10021	Nut - Jam 3/8-24 NI	2
for 21.	WASHNFC3	WASHER #3 3/8 AN 960 C616L	2
for 22 and 23.	INSR10001	Rubber Insert - Round	2
for 22.	BRKT20031	Saddle Spacer Bracket	1



©

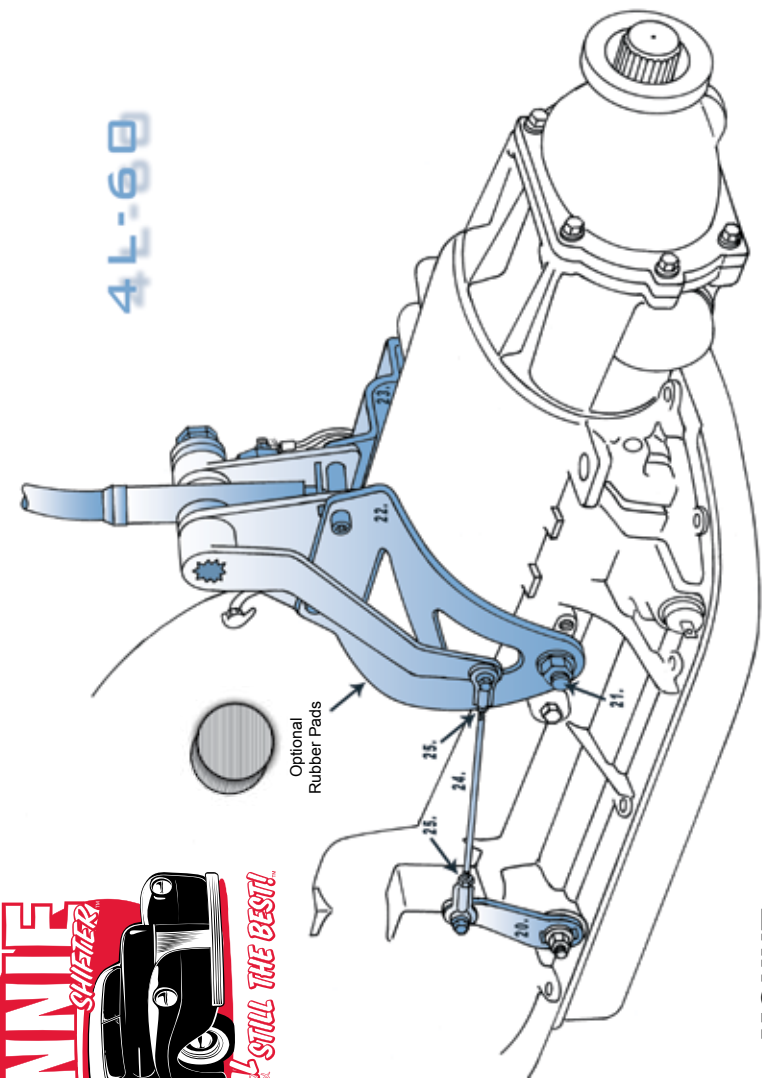

4L-60

MID - MOUNT
Diagram Items 20 - 25