

# QUICK ADJUST TROLLEY



## Features

- Lightweight, robust construction.
- Super-quick adjustment to most I, S, and W-Beams (see measurements below)
- Safety handle lock
- Durable baked-enamel paint protection
- Precision ball bearing trolley wheels
- Anti-drop plate
- Stainless steel ID tag
- Individual test certificate and serial number

**Standards - CE,  
ASME B30.11, ASME B30.16**

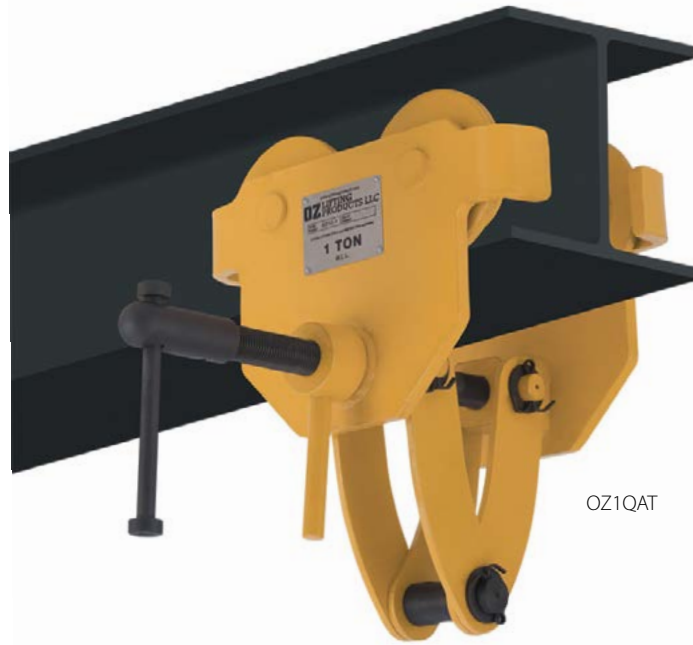

OZ1QAT

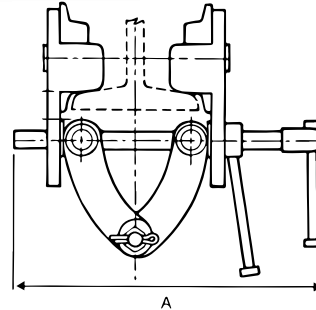
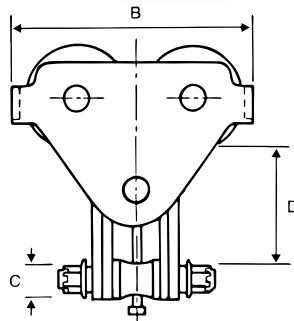

	OZ05QAT	OZ1QAT	OZ2QAT	OZ3QAT	OZ5QAT	OZ10QAT
Capacity (tons)	.5	1	2	3	5	10
Adjustable Flange Width (in)	3.63-7.12	2.48-8.27	2.99-8.27	2.99-8.27	3.94-12.01	6.89-12.01
Max Flange Thickness (in)	1.44	2	2.17	1.42	3.07	2.13
Dimensional Information (in)	A	11.75	13.98	14.17	14.17	18.50
	B	8.00	9.53	11.06	12.91	14.84
	C	.75	.88	.88	.97	1.11
(min-max)	D	5.87-7.12	5.75-7.22	6.06-7.22	6.35-7.97	8.81-10.61
Minimum Curve Radius (ft)	3.28	3.28	3.61	4.26	4.60	5.57
Net Weight (lbs)	13	25	38	57	102	205

\*Dimensions are for reference only and subject to change without notice.

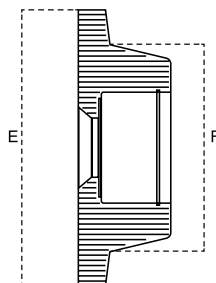
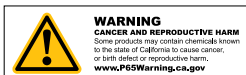

	OZ05QAT	OZ1QAT	OZ2QAT	OZ3QAT	OZ5QAT	OZ10QAT
E (in)	3.22	4.02	5.00	5.79	6.30	7.34
F (in)	2.28	2.96	3.55	4.34	4.81	5.96

\*Dimensions are for reference only and subject to change without notice.