

Cross-Over Ladders

Mount where you need permanent access at crossover points. The upper platform features removable two sided 42 $\frac{3}{8}$ " high handrail with 21" mid-rail and fixed 4" toeboards to prevent objects from rolling off. Serrated steps for extra grip and safety are 23 $\frac{1}{2}$ " wide and 7" deep with a step spacing of 10". The angle of the steps are 58°. The overall ladder width is 29 $\frac{1}{4}$ ". Ground legs include floor mounting pads. Units must be anchored to the floor. Units are all steel construction and can be knock-down for storage and shipping. Uniform capacity is 500 pounds. Meets ANSI A14.7 and OSHA 29 CFR 1910.24. Baked-in powder-coated toughness.

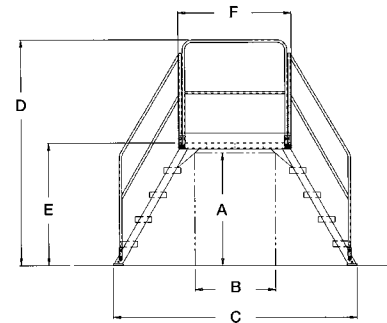

model COL-4-36-44



MODEL NUMBER	NUMBER OF STEPS	A	B	C	D	E	F	WEIGHT (POUND)
COL-3-26-14	3	28 $\frac{1}{4}$ "	14 $\frac{1}{8}$ "	54 $\frac{1}{2}$ "	72 $\frac{7}{8}$ "	30"	24"	264
COL-3-26-23	3	28 $\frac{1}{4}$ "	26 $\frac{1}{8}$ "	66 $\frac{1}{2}$ "	72 $\frac{7}{8}$ "	30"	36"	282
COL-3-26-33	3	28 $\frac{1}{4}$ "	38 $\frac{1}{8}$ "	78 $\frac{1}{2}$ "	72 $\frac{7}{8}$ "	30"	48"	315
COL-3-26-44	3	28 $\frac{1}{4}$ "	50 $\frac{1}{8}$ "	90 $\frac{1}{2}$ "	73"	30"	60"	349
COL-4-36-14	4	38 $\frac{1}{4}$ "	14 $\frac{1}{8}$ "	67"	82 $\frac{7}{8}$ "	40"	24"	326
COL-4-36-23	4	38 $\frac{1}{4}$ "	26 $\frac{1}{8}$ "	79"	82 $\frac{7}{8}$ "	40"	36"	348
COL-4-36-33	4	38 $\frac{1}{4}$ "	38 $\frac{1}{8}$ "	91"	82 $\frac{7}{8}$ "	40"	48"	380
COL-4-36-44	4	38 $\frac{1}{4}$ "	50 $\frac{1}{8}$ "	103"	83"	40"	60"	385
COL-5-46-14	5	48 $\frac{1}{4}$ "	14 $\frac{1}{8}$ "	79 $\frac{1}{2}$ "	92 $\frac{7}{8}$ "	50"	24"	340
COL-5-46-23	5	48 $\frac{1}{4}$ "	26 $\frac{1}{8}$ "	91 $\frac{1}{2}$ "	92 $\frac{7}{8}$ "	50"	36"	380
COL-5-46-33	5	48 $\frac{1}{4}$ "	38 $\frac{1}{8}$ "	103 $\frac{1}{2}$ "	92 $\frac{7}{8}$ "	50"	48"	420
COL-5-46-44	5	48 $\frac{1}{4}$ "	50 $\frac{1}{8}$ "	115 $\frac{1}{2}$ "	93"	50"	60"	440
COL-6-56-14	6	58 $\frac{1}{4}$ "	14 $\frac{1}{8}$ "	92"	102 $\frac{7}{8}$ "	60"	24"	348
COL-6-56-23	6	58 $\frac{1}{4}$ "	26 $\frac{1}{8}$ "	104"	102 $\frac{7}{8}$ "	60"	36"	398
COL-6-56-33	6	58 $\frac{1}{4}$ "	38 $\frac{1}{8}$ "	116"	102 $\frac{7}{8}$ "	60"	48"	401
COL-6-56-44	6	58 $\frac{1}{4}$ "	50 $\frac{1}{8}$ "	128"	103"	60"	60"	460

Cross-Over Vertical Ladders

Mount where you need permanent access at crossover points. The upper platform features removable two sided 42 $\frac{3}{8}$ " high handrail with 21" mid-rail and fixed 4" toeboards to prevent objects from rolling off. Serrated platform for extra grip material for safety are 23-9/16" wide with step spacing of 12". Ground legs include floor mounting pads. Units must be anchored to the floor. Units are all steel construction and can be knock-down for storage and shipping. Uniform capacity is 500 pounds. Meets OSHA 29 CFR 1910.27. Baked-in powder-coated toughness.

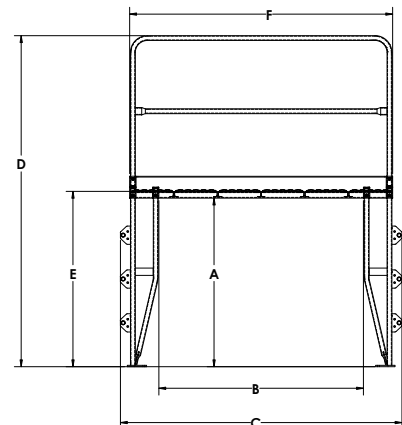

MODEL NUMBER	NUMBER OF STEPS	A	B	C	D	E	F	WEIGHT (POUND)
COLV-3-34-8	3	34 $\frac{3}{16}$ "	8"	29"	78 $\frac{5}{8}$ "	36"	24"	198
COLV-3-34-20	3	34 $\frac{3}{16}$ "	20"	41"	78 $\frac{5}{8}$ "	36"	36"	232
COLV-3-34-32	3	34 $\frac{3}{16}$ "	32"	53"	78 $\frac{5}{8}$ "	36"	48"	267
COLV-3-34-44	3	34 $\frac{3}{16}$ "	44"	65"	78 $\frac{5}{8}$ "	36"	60"	301
COLV-3-34-56	3	34 $\frac{3}{16}$ "	56"	77"	78 $\frac{5}{8}$ "	36"	72"	336
COLV-4-46-8	4	46 $\frac{3}{16}$ "	8"	29"	90 $\frac{5}{8}$ "	48"	24"	183
COLV-4-46-20	4	46 $\frac{3}{16}$ "	20"	41"	90 $\frac{5}{8}$ "	48"	36"	217
COLV-4-46-32	4	46 $\frac{3}{16}$ "	32"	53"	90 $\frac{5}{8}$ "	48"	48"	252
COLV-4-46-44	4	46 $\frac{3}{16}$ "	44"	65"	90 $\frac{5}{8}$ "	48"	60"	286
COLV-4-46-56	4	46 $\frac{3}{16}$ "	56"	77"	90 $\frac{5}{8}$ "	48"	72"	321
COLV-5-58-8	5	58 $\frac{3}{16}$ "	8"	29"	102 $\frac{5}{8}$ "	60"	24"	202
COLV-5-58-20	5	58 $\frac{3}{16}$ "	20"	41"	102 $\frac{5}{8}$ "	60"	36"	237
COLV-5-58-32	5	58 $\frac{3}{16}$ "	32"	53"	102 $\frac{5}{8}$ "	60"	48"	271
COLV-5-58-44	5	58 $\frac{3}{16}$ "	44"	65"	102 $\frac{5}{8}$ "	60"	60"	306
COLV-5-58-56	5	58 $\frac{3}{16}$ "	56"	77"	102 $\frac{5}{8}$ "	60"	72"	340
COLV-6-70-8	6	70 $\frac{3}{16}$ "	8"	29"	114 $\frac{5}{8}$ "	72"	24"	222
COLV-6-70-20	6	70 $\frac{3}{16}$ "	20"	41"	114 $\frac{5}{8}$ "	72"	36"	256
COLV-6-70-32	6	70 $\frac{3}{16}$ "	32"	53"	114 $\frac{5}{8}$ "	72"	48"	291
COLV-6-70-44	6	70 $\frac{3}{16}$ "	44"	65"	114 $\frac{5}{8}$ "	72"	60"	323
COLV-6-70-56	6	70 $\frac{3}{16}$ "	56"	77"	114 $\frac{5}{8}$ "	72"	72"	360
COLV-7-82-8	7	82 $\frac{3}{16}$ "	8"	29"	126 $\frac{5}{8}$ "	84"	24"	244
COLV-7-82-20	7	82 $\frac{3}{16}$ "	20"	41"	126 $\frac{5}{8}$ "	84"	36"	279
COLV-7-82-32	7	82 $\frac{3}{16}$ "	32"	53"	126 $\frac{5}{8}$ "	84"	48"	313
COLV-7-82-44	7	82 $\frac{3}{16}$ "	44"	65"	126 $\frac{5}{8}$ "	84"	60"	348
COLV-7-82-56	7	82 $\frac{3}{16}$ "	56"	77"	126 $\frac{5}{8}$ "	84"	72"	382