

**FREE  
SPARE SET  
OF LATCHES**

# CHAIN HOIST

## Features

- Stainless Steel Type 304 Construction for Corrosion Resistance
- Fully Enclosed Gearing
- Fully Machined Lift Wheel
- Designed for Lifting or Pulling
- Minimal Load Lifting Effort
- Individual Test Certificate and Serial Number
- Forged Stainless Steel Hooks and Safety Latches
- Stainless Steel Hand & Load Chain
- Weather Proof Load Holding Brake
- All Gears and Shafts Run on Roller Bearings
- Stainless Steel Riveted ID Tags
- Low Headroom

**Standards - CE, AS1418.2, ASME B30.21, ASME B30.16**



OZSS010-CH

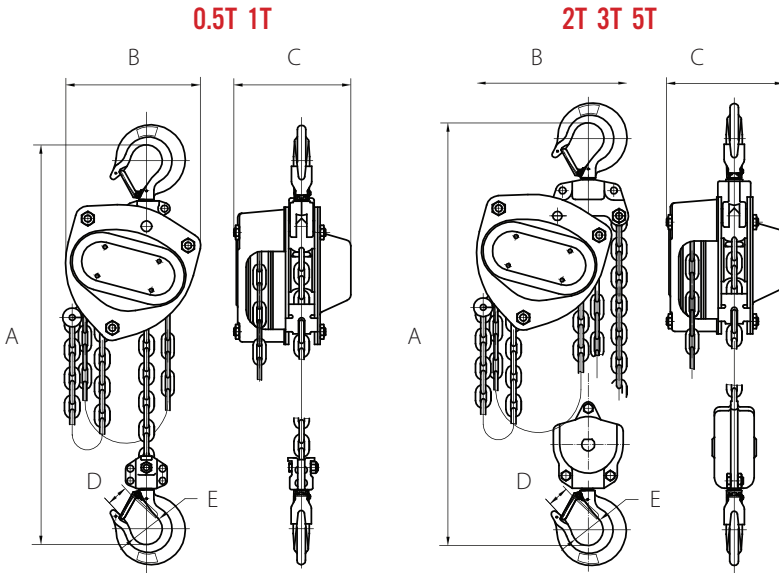

	OZSS005-CH	OZSS010-CH	OZSS020-CH	OZSS030-CH*	OZSS050-CH*
Capacity (tons)	0.5	1	2	3	5
Falls of Chain	1	1	2	2	3
Effort to Lift S.W.L (lbs)	67	67	74	74	74
Loadchain Diameter (mm)	7	7	7	9	9
Dimensional Information (in)	A	14.8	14.8	16.73	22.24
	B	6.77	6.77	7.56	9.06
	C	5.94	5.94	5.94	6.81
Hook-opening, upper & lower	D	1.02	1.02	1.33	1.53
	E	1.57	1.57	1.96	2.16
Net Weight of Head Only (lbs)	16.3	16.3	22.9	34.7	66.1

\*Chain Hoists 3 Ton and 5 Ton available. Special order.

**Standard Lift: 10, 15, 20, 30 ft.**

**We also do custom rigging**

Dimensions are for reference only and subject to change without notice.

